



TYPES OF BURY  
CABLE AND CONDUIT  
BORED, TRENCHED, AND PLOWED

GENERAL NOTES:

1. UNDERGROUND CONDUIT SHALL BE PLACED AT 42" MINIMUM COVER UNLESS OTHERWISE SPECIFIED ON THE PLANS.
2. UNDERGROUND CONDUIT SHALL BE PLACED AT 48" MINIMUM COVER UNDER STREAM, CREEK AND DRAINAGE DITCH'S UNLESS OTHERWISE SPECIFIED ON THE PLANS.
3. IF WHILE LOWERING THE CONDUIT THERE IS NOT ENOUGH SLACK, ADDITIONAL CONDUIT SHALL BE ADDED. EMPTY CONDUITS CAN BE CUT AND HAVE NEW CONDUIT FUSED ON. CONDUITS WITH FIBER INSTALLED SHALL BE RING CUT WITH A TUBE CUTTER SO AS NOT TO DAMAGE THE FIBER.
4. ALL CONDUIT USED ABOVE GROUND SHALL BE PVC COATED GALVANIZED RIGID STEEL ACCORDING TO SECTION 811 OF THE STANDARD SPECIFICATIONS, AS MODIFIED BY THE TOLLWAY SUPPLEMENTAL SPECIFICATIONS.

5. LOCATE/TRACE WIRE SHALL BE DIRECT BURIED WITH EVERY CONDUIT BUNDLE PATH AS CLOSE TO THE CENTER OF THE CONDUITS AS POSSIBLE. LOCATE/TRACE WIRE SHALL NOT BE INSTALLED IN A CONDUIT WITHOUT APPROVAL OF THE ENGINEER.
6. WHEN AN OPTIC FIBER CONDUIT SEPARATES FROM A CONDUIT BUNDLE OR DUCT BANK, AN ADDITIONAL LOCATE WIRE SHALL BE INSTALLED WITH THAT SEPARATE CONDUIT PATH GOING BACK TO THE PREVIOUS HANDHOLE.
7. ALL LOCATE/TRACE WIRE WILL BE TESTED PER SPECIFICATIONS PRIOR TO ANY FIBER BEING INSTALLED.
8. ALL UNUSUED CONDUIT SHALL HAVE 1200 LB MULE TAPE INSTALLED FOR FUTURE USE.

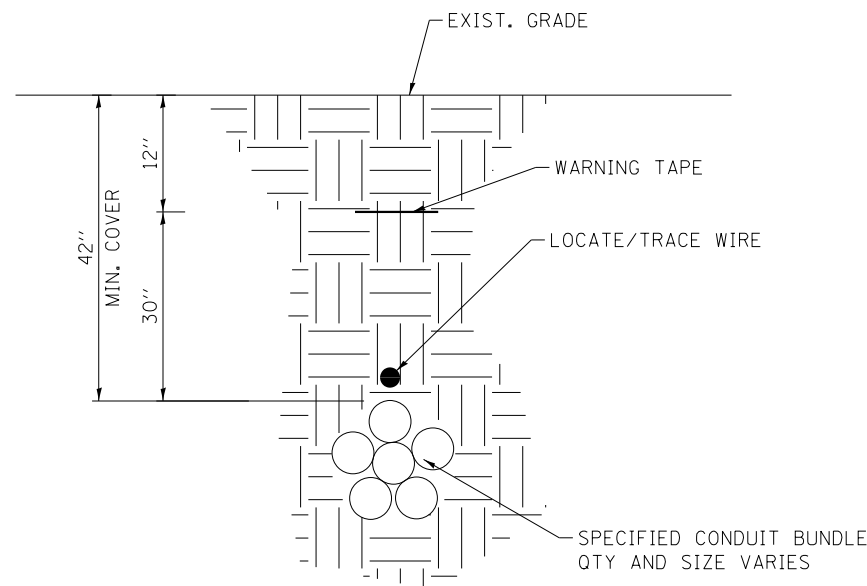

PLOWED CONDUIT BUNDLES  
QTY VARIES

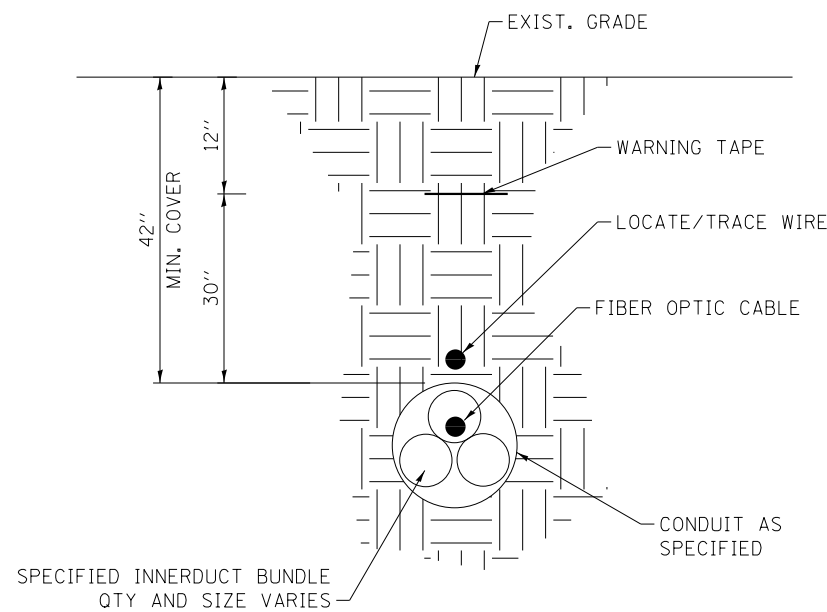

BORED CONDUIT WITH FIBER OPTIC CABLE AND/OR MULTIPLE INNERDUCTS  
AS REQUIRED

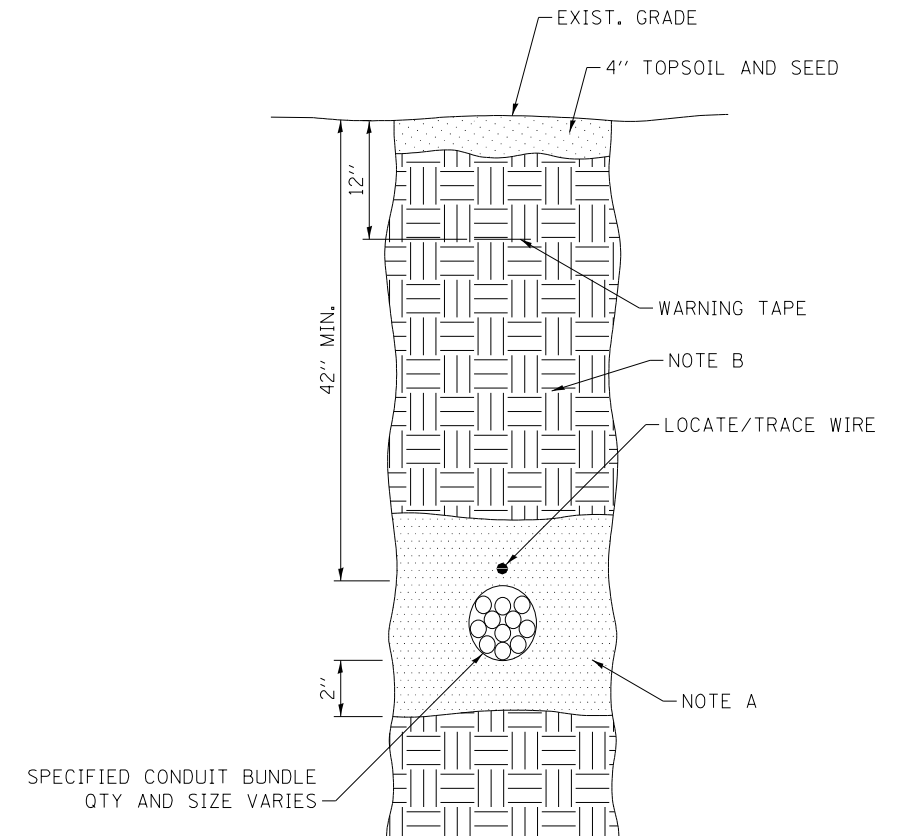

CONSTRUCTION NOTES TRENCHED CONDUIT BUNDLES

- A. A MINIMUM OF 2" OF SAND SHALL BE PLACED UNDER THE CONDUIT. SAND SHALL TRANSITION TO BACKFILL ACCORDING TO NOTE B 4" ABOVE CONDUIT.
- B. BACKFILL SHALL BE ACCORDING TO ARTICLE 810.04 OF THE STANDARD SPECIFICATIONS.

TRENCHED CONDUIT BUNDLES



DATE	REVISIONS
3-01-2019	ADDED NEW TORSION ASSIST TYPE HANDHOLE DRAWING, ADDED LOCATE AND TRACER WIRE

FIBER OPTIC SYSTEM  
TYPICALS AND DRAWINGS

STANDARD L1-01

*Paul Kovacs*  
APPROVED..... CHIEF ENGINEERING OFFICER DATE 3-31-2017.....

TYPICAL ROAD CROSSINGS

TYPICAL ROAD CROSSING

PLAN VIEW

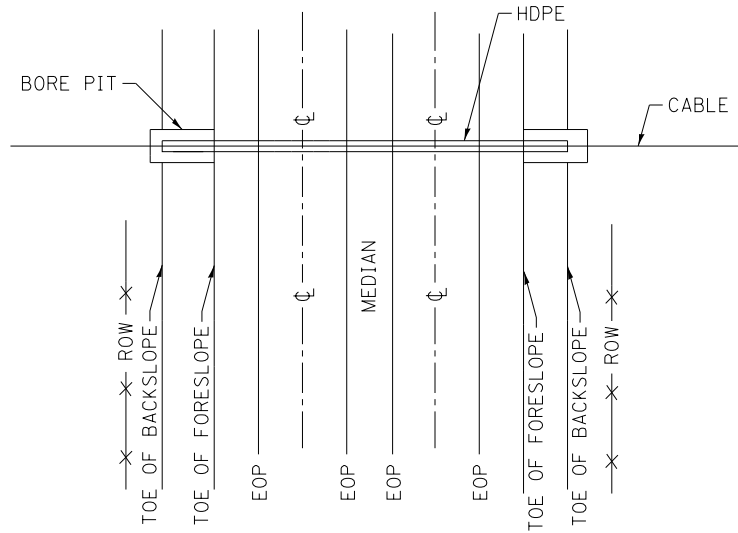

PROFILE VIEW

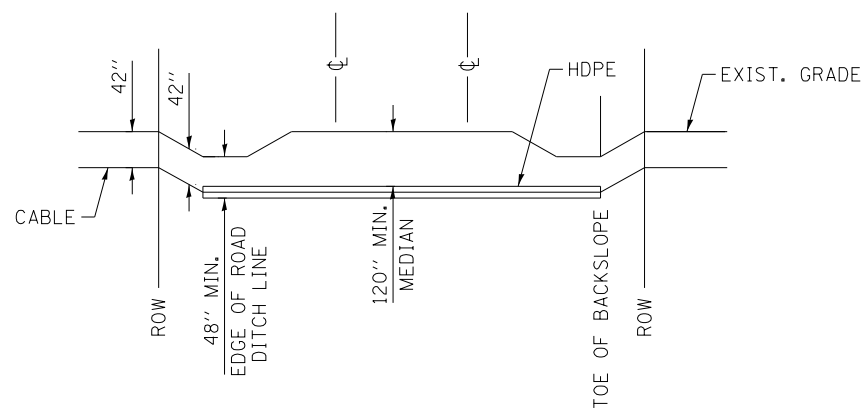

GENERAL NOTES:

1. UNDERGROUND CONDUIT SHALL BE PLACED AT 42" MINIMUM COVER UNLESS OTHERWISE SPECIFIED ON THE PLANS.
2. UNDERGROUND CONDUIT SHALL BE PLACED AT 48" MINIMUM COVER UNDER STREAM, CREEK AND DRAINAGE DITCH'S UNLESS OTHERWISE SPECIFIED ON THE PLANS.
3. THE MINIMUM COVER UNDER A PUBLIC ROADWAY, ILLINOIS TOLLWAY HIGHWAY AND RAMPS SHALL BE 120" OR SUCH GREATER DEPTH AS MAY BE REQUIRED TO CLEAR THE PAVEMENT STRUCTURE.
4. IF WHILE LOWERING THE DUCTS, THERE IS NOT ENOUGH SLACK IN THE DUCTS, ADDITIONAL DUCT SHALL BE ADDED. EMPTY DUCTS CAN BE CUT AND HAVE NEW DUCT FUSED ON. DUCTS WITH FIBER INSTALLED SHALL BE RING CUT WITH A TUBE CUTTER SO AS NOT TO DAMAGE THE FIBER.
5. HDPE CASING SHALL EXTEND FROM TOE OF BACK SLOPE TO TOE OF BACK SLOPE UNLESS OTHERWISE APPROVED.
6. BORE AND RECEIVING PITS SHALL BE A MINIMUM OF 30 FEET FROM THE EDGE OF SHOULDER ON TOLL HIGHWAYS UNLESS OTHERWISE APPROVED.
7. TOP OF CASING SHALL BE A MINIMUM OF 48" BELOW THE DESIGNED DITCH GRADES ON EACH SIDE OF HIGHWAY.
8. ENDS OF ALL CASING SHALL BE FOAM PLUGGED. (ARNCO HYDRA-SEAL S-60 OR ENGINEER APPROVED EQUAL).
9. PITS FOR BORING ARE NOT PERMITTED IN THE HIGHWAY MEDIAN.
10. TOP HDPE CASING SHALL BE A MIN. OF 120" BELOW LOWEST ILLINOIS TOLLWAY ROAD SURFACE.
11. ALL CONDUIT USED ABOVE GROUND SHALL BE PVC COATED GALVANIZED RIGID STEEL ACCORDING TO SECTION 811 OF THE IDOT STANDARD SPECIFICATIONS, AS MODIFIED BY THE ILLINOIS TOLLWAY SUPPLEMENTAL SPECIFICATIONS.
12. HANDHOLES SHALL BE INSTALLED ON BOTH SIDES OF ANY STREAM, CREEK, OR RAILROAD CROSSING.

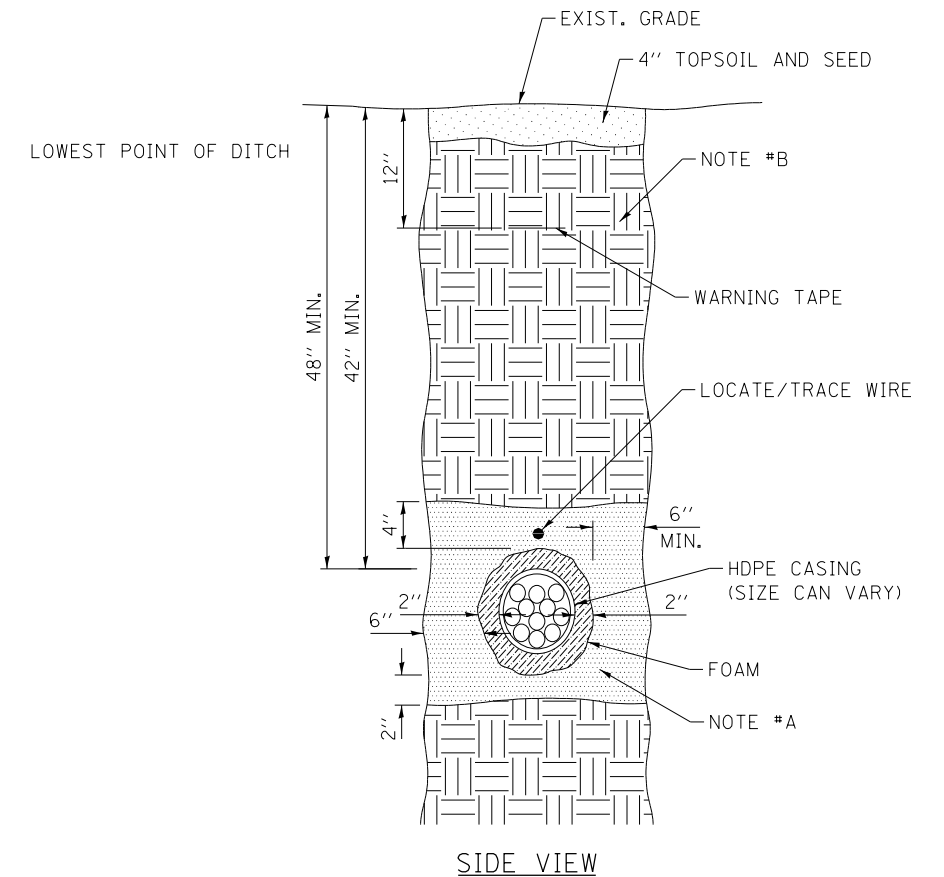

SIDE VIEW

CONSTRUCTION NOTES TRENCHED HDPE BUNDLES

- A. A MINIMUM OF 2" OF SAND SHALL BE PLACED UNDER THE CONDUIT. SAND SHALL TRANSITION TO BACKFILL ACCORDING TO NOTE B 4" ABOVE CONDUIT.
- B. BACKFILL SHALL BE ACCORDING TO ARTICLE 810.04 OF THE STANDARD SPECIFICATIONS.

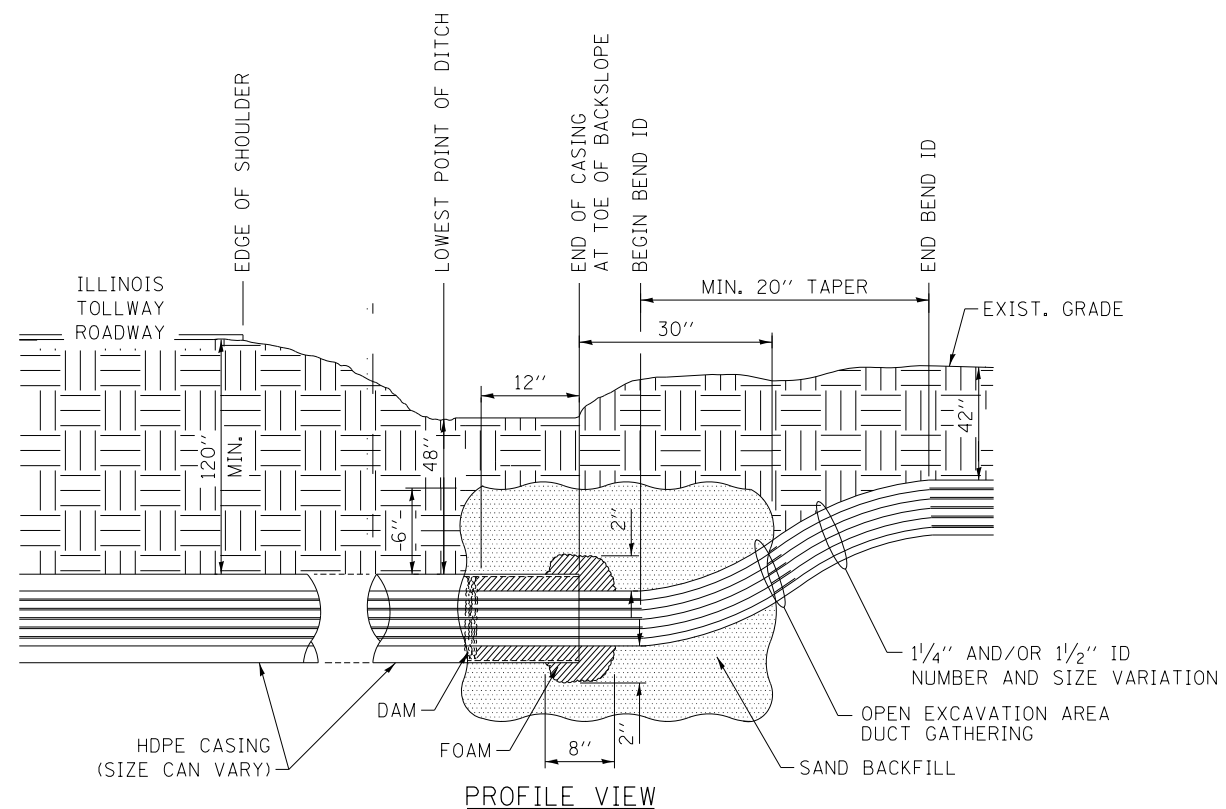

PROFILE VIEW

APPROVED *Paul Kovacs* CHIEF ENGINEER DATE 3-31-2017



OUTSIDE PLANT TYPICAL BORES

TYPICAL RAILROAD BORE OR JACK

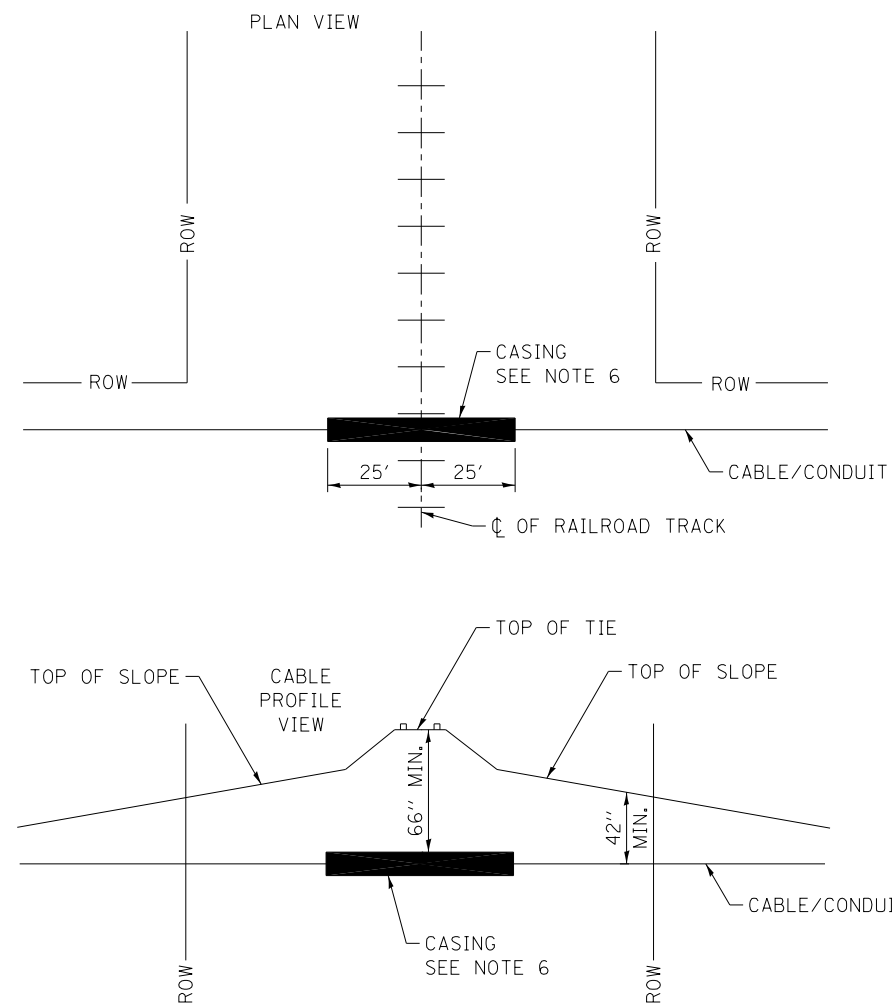

NOTES FOR RAILROAD BORE OR JACK

1. CASING SHALL EXTEND 25 FT. EACH SIDE OF C.L. OF OUTERMOST TRACK OR AS DICTATED BY RAILROAD PERMIT.
2. R.R. BALLAST SHALL NOT BE DISTURBED.
3. BORE AND RECEIVING PITS SHALL NOT BE EXCAVATED CLOSER THAN 10 FT. FROM THE TOE OF SLOPE ON EACH SIDE OF TRACK.
4. ENDS OF ALL CASING SHALL BE FOAM PLUGGED (ARNCO HYDRA-SEAL S-60 OR ENGINEER APPROVAL EQUAL). SEE SHEET 2 OF THIS SERIES.
5. ALL OPERATIONS SHALL MEET REGULATING AGENCY REQUIREMENTS.
6. CASING AS REQUIRED BY CUSTOMER OR RAILROAD OWNER.
7. DEPTH TO TOP OF CASING TO TOP OF RR TIE MAY BE GREATER THAN 66" AS REQUIRED BY RAILROAD OWNER, NEVER LESS THAN 66".

TYPICAL CITY ST. AND DRIVEWAY BORE OR JACK

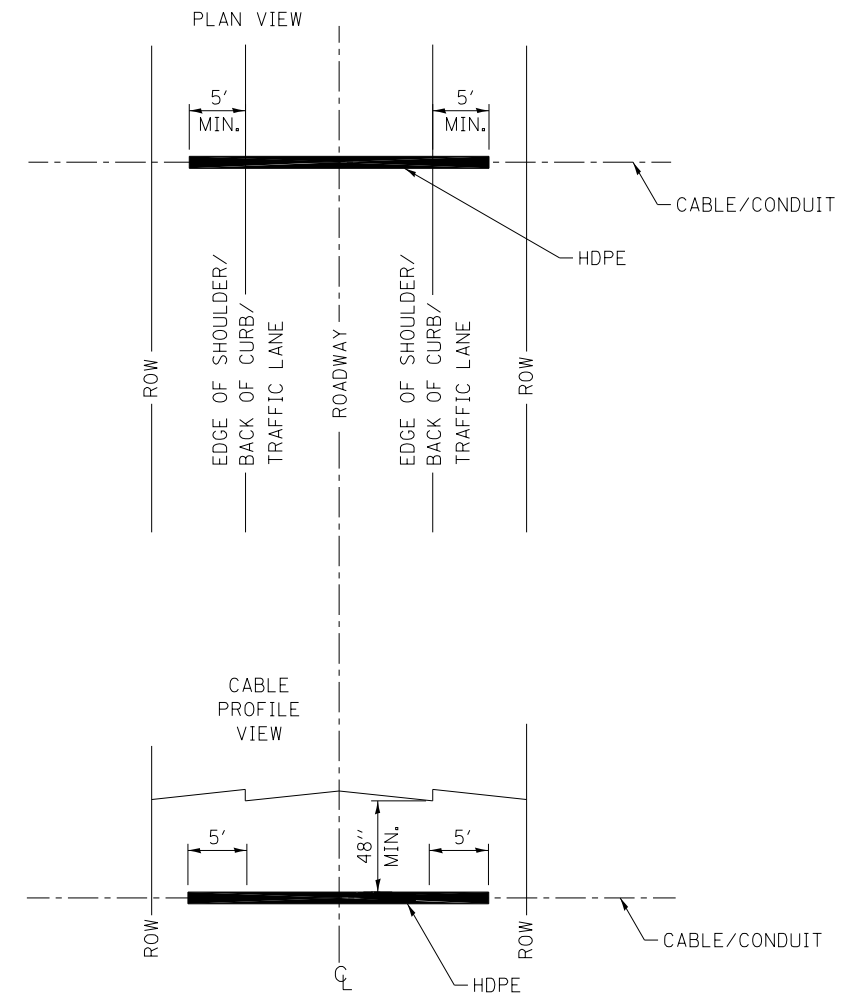

NOTES FOR CITY STREET AND DRIVEWAY BORE OR JACK

1. HDPE SHALL EXTEND 5 FT. EACH SIDE OF EDGE OF SHOULDER/BACK OF CURB.
2. BORE AND RECEIVING PITS SHALL NOT BE EXCAVATED WITHIN 5 FT. OF EDGE OF SHOULDER/BACK OF CURB.
3. ENDS OF ALL HDPE SHALL BE FOAM PLUGGED. (ARNCO HYDRA-SEAL S-60 OR ENGINEER APPROVED EQUAL). SEE SHEET 2 OF THIS SERIES.
4. HDPE SHALL BE A MINIMUM OF 48" BELOW PAVEMENT ELEVATION TO TOP OF HDPE, MAY BE GREATER THAN 48" AS REQUIRED BY CITY, VILLAGE AND/OR TWP/COUNTY.
5. ALL OPERATIONS SHALL MEET REGULATING AGENCY REQUIREMENTS.



UTILITY AVOIDANCE DETAIL

NOTES:

1. IF 18" MIN COVER CANNOT BE ACHIEVED, HDPE(S) MUST BE PLACED UNDER EXISTING UTILITY.
2. 12" MIN SEPARATION MUST BE ADHERED TO BETWEEN GALVANIZED RIGID STEEL/CASING HDPE AND EXISTING UTILITY.
3. NO DIRECT BURY UNDER ANY EXISTING UTILITY.
4. 18" TO 24" SEPARATION FOR OIL, GAS UTILITY BETWEEN PIPE AND CONDUIT.
5. IF CROSSING AN EXISTING UTILITY, SHOULD BE CONSTRUCTED AS CLOSE TO 90° AS POSSIBLE.

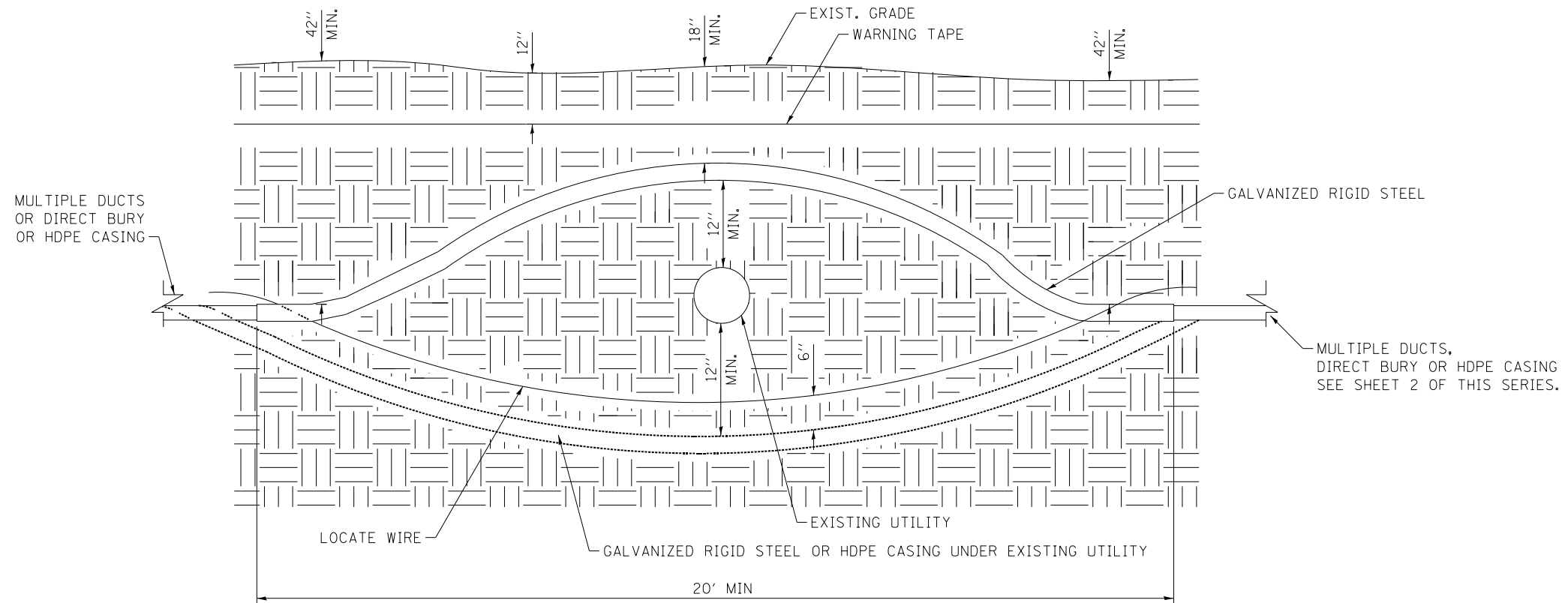

FUSION COUPLINGS DETAIL

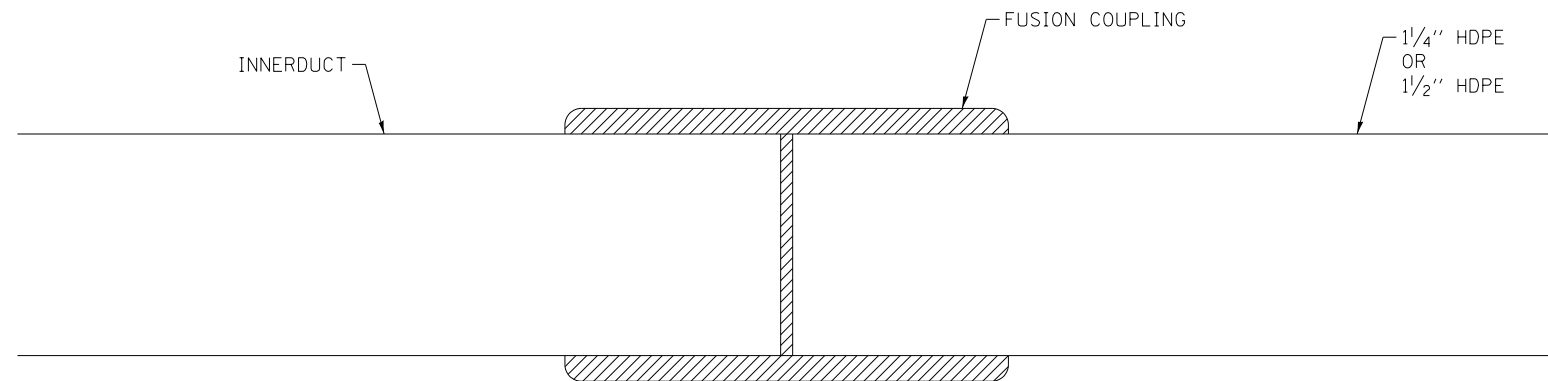

NOTE:  
 IN A PROPER ELECTROFUSION JOINT, MOLTEN MATERIAL FLOWS TO THE COLD ZONE WHERE IT SOLIDIFIES AND FREEZES OFF THE ESCAPE PATH. WITH THE MOLTEN MATERIAL CONTAINED, MELT PENETRATION WILL BUILD INTERFACE PRESSURE. WIRE WINDINGS WILL FLOW IN A DESIGNED AND CONTROLLED PATTERN AND A PROPER BONDING OF MATERIALS CAN BE OBTAINED.

PROPER FUSION DETAIL

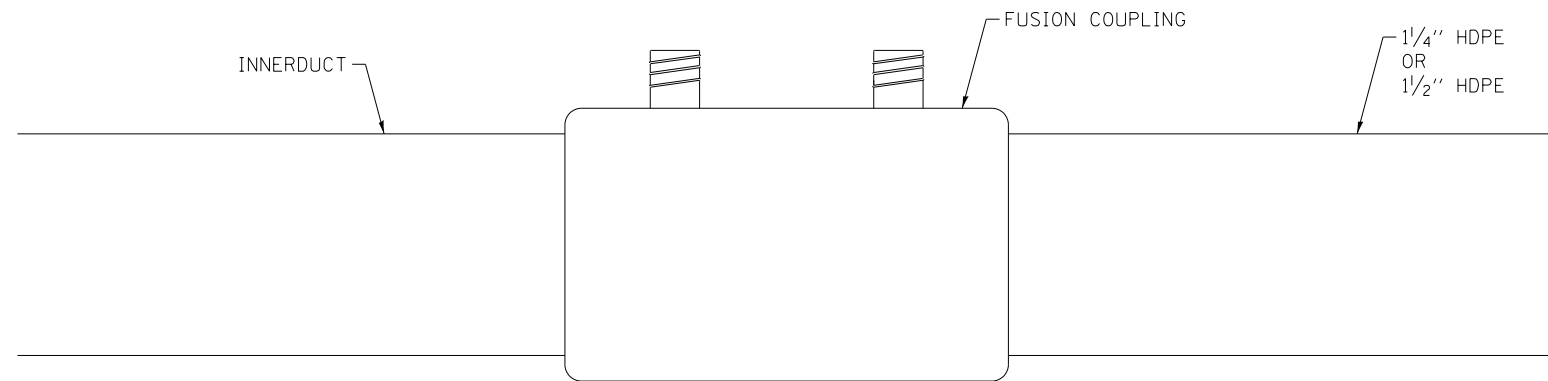

STANDARD JOINING PROCEDURES

1. ONLY FUSION COUPLINGS SHALL BE USED. COMPRESSION COUPLINGS SHALL NOT BE ALLOWED.
2. SHALL INSTALL PER FUSION COUPLING MANUFACTURER RECOMMENDATIONS.
3. THE PIPE SHALL HAVE A SQUARE EVEN CUT.
4. REMOVE ANY BURRS OR SHAVING FROM THE PIPE ENDS THAT MAY HAVE DEVELOPED DURING THE CUTTING PROCESS.
5. CLEAN PIPE ENDS INSIDE AND OUT WITH A CLEAN CLOTH TO REMOVE ANY DIRT OR CONTAMINANTS.
6. PIPE PREPARATION AND CONTAMINATION ARE VERY IMPORTANT CONSIDERATIONS IN THE ELECTROFUSION PROCESS. THEREFORE, CAREFUL ATTENTION SHALL BE GIVEN TO PROPER SCRAPING AND CLEANING PROCEDURES.
7. SCRAPE PIPE ENDS TO REMOVE ANY OXIDATION OR SURFACE CONTAMINATION. FOR BEST RESULTS, SECURE TOOL ON PIPE AND MAKE TWO REVOLUTIONS.
8. DISCONNECT LEADS FROM FITTING. CLAMPING DEVICE SHALL REMAIN IN PLACE TO SECURE PIPE AND FITTING DURING THE RECOMMENDED COOLING TIME. AFTER REMOVING CLAMP, ADDITIONAL COOLING TIME SHALL BE ALLOWED BEFORE SUBJECTING THE JOINT TO BENDING, BURYING, PRESSURE TESTING, OR SIMILAR HANDLING AND BACKFILL STRESS.

NOTE: IN THE EVENT OF OUT-OF-ROUND PIPE, IT IS IMPORTANT TO ASSURE AN ADEQUATE AND EVEN SCRAPE IS ACHIEVED AROUND THE ENTIRE CIRCUMFERENCE OF THE PIPE. A RUBBER PIPE STOPPER CAN BE PLACED IN THE END OF THE PIPE TO AID IN ROUNDING THE AREA TO BE SCRAPED.

9. MULTIPLE DUCTS FUSION SHALL BE STAGGERED AND AFTER COMPLETION SHALL BE BOUND TOGETHER WITH TY-STRAPS (AT 5' SPACING) SO TO OCCUPY MINIMUM POSSIBLE SPACE AND THEN BACKFILLED.



*Paul Kovacs*  
 APPROVED..... CHIEF ENGINEER..... DATE 3-31-2017..

HANDHOLE

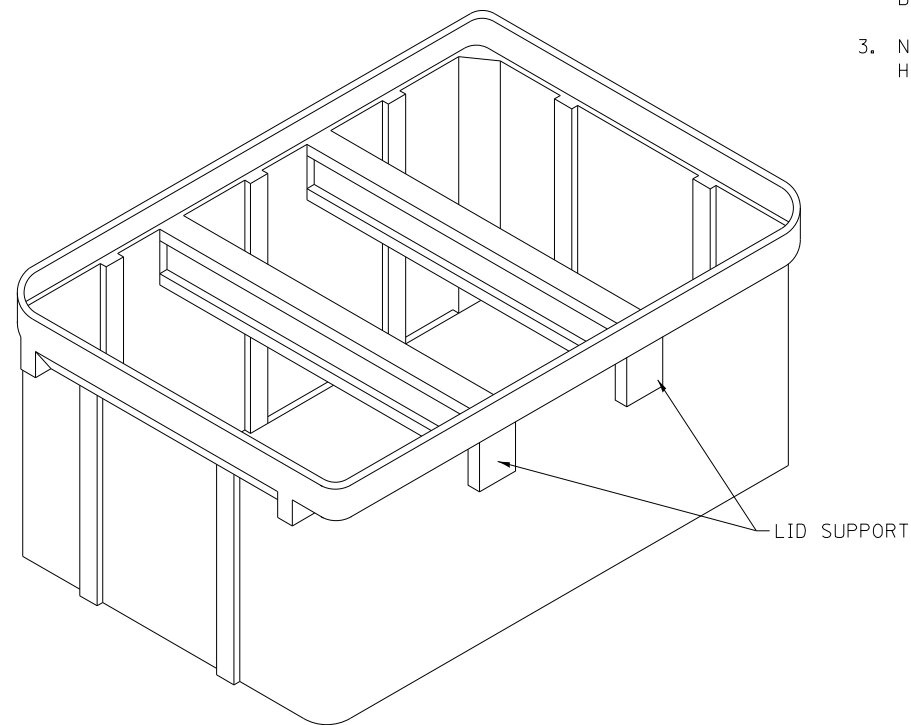
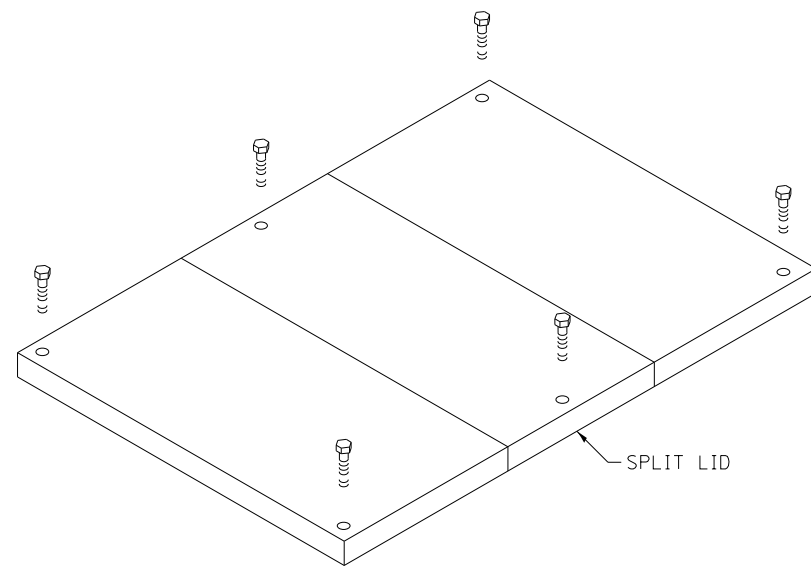

4'x6' HANDHOLE  
 2 OR 3 SECTION SPLIT LID  
 (PG STYLE LARGE BOX)  
 5-1 1/4" OR MORE DUCTS

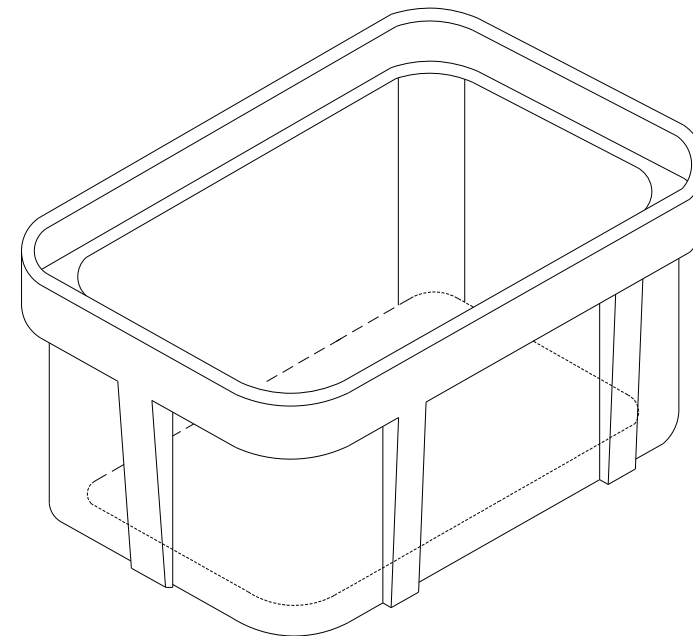
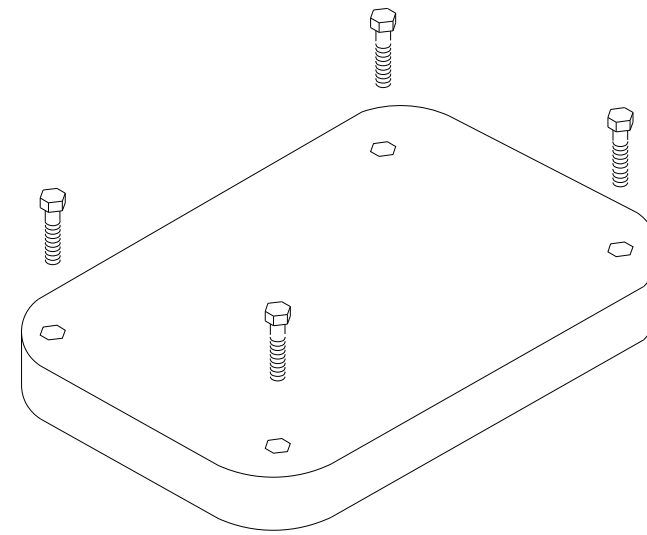

3'x5' HANDHOLE  
 SINGLE OR SPLIT LID  
 LESS THAN 5-1 1/4" DUCTS

NOTES:

1. NO MARKING ON LID.
2. ALL BOLTS SHALL BE 1/2" x 3 1/2" HEX HEAD ASTM STANDARD F593C STAINLESS STEEL BOLTS.
3. NO CORING/DRILLING OR ALTERATION OF HANDHOLE SHALL BE ALLOWED.

*Paul Kovacs*  
 APPROVED..... CHIEF ENGINEER..... DATE 3-31-2017.....

HDPE AND FIBER OPTIC CABLE PLACEMENT IN HANDHOLE

TABLE "A"

FIBER COUNT	MINIMUM BEND RADIUS (AT REST)
24F	6"
48F	6"
72F	8"
96F	8"
144F	10"
188F	10"
288F	10"
432F	10"
864F	11"

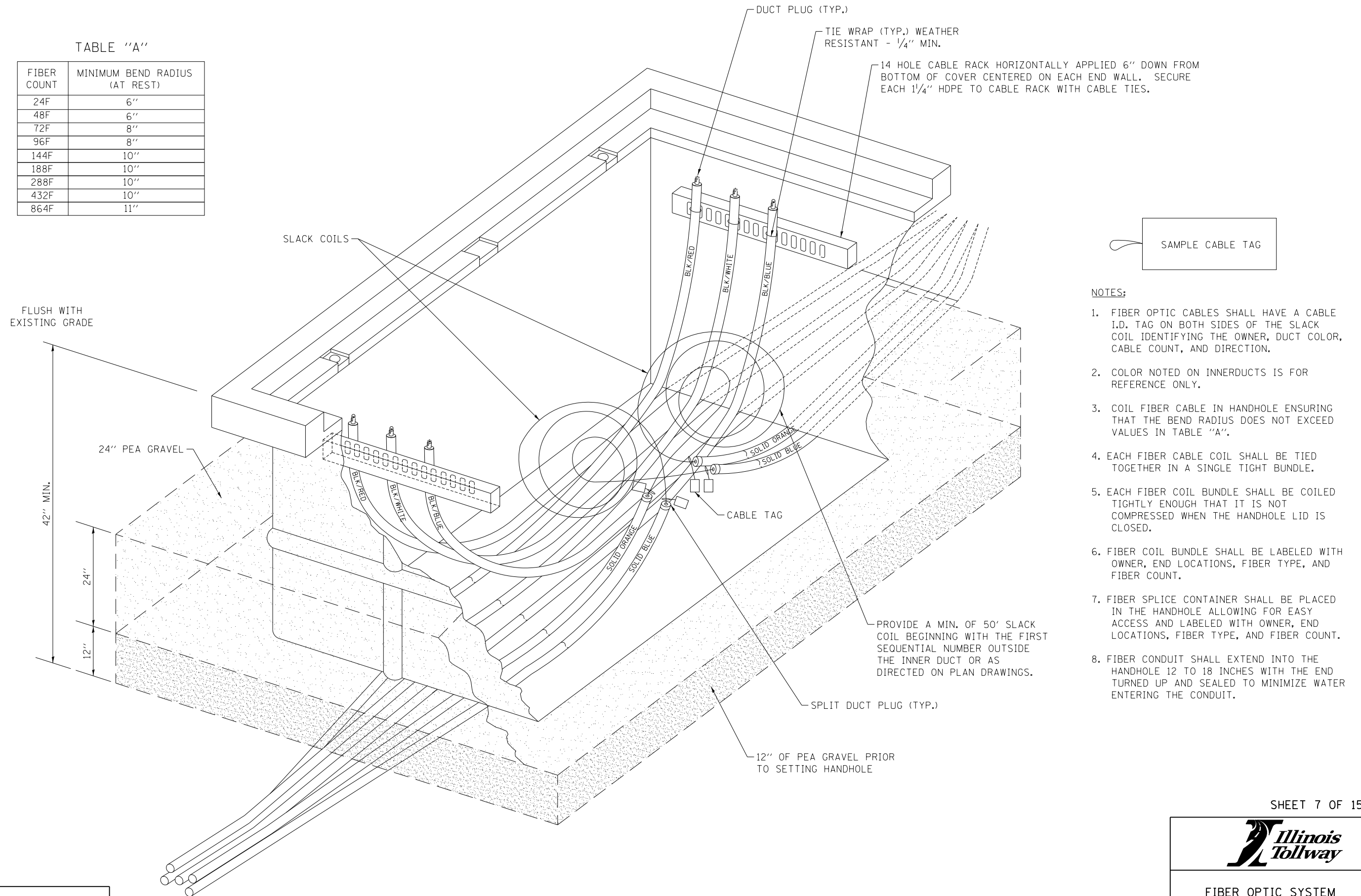

NOTES:

1. FIBER OPTIC CABLES SHALL HAVE A CABLE I.D. TAG ON BOTH SIDES OF THE SLACK COIL IDENTIFYING THE OWNER, DUCT COLOR, CABLE COUNT, AND DIRECTION.
2. COLOR NOTED ON INNERDUCTS IS FOR REFERENCE ONLY.
3. COIL FIBER CABLE IN HANDHOLE ENSURING THAT THE BEND RADIUS DOES NOT EXCEED VALUES IN TABLE "A".
4. EACH FIBER CABLE COIL SHALL BE TIED TOGETHER IN A SINGLE TIGHT BUNDLE.
5. EACH FIBER COIL BUNDLE SHALL BE COILED TIGHTLY ENOUGH THAT IT IS NOT COMPRESSED WHEN THE HANDHOLE LID IS CLOSED.
6. FIBER COIL BUNDLE SHALL BE LABELED WITH OWNER, END LOCATIONS, FIBER TYPE, AND FIBER COUNT.
7. FIBER SPLICE CONTAINER SHALL BE PLACED IN THE HANDHOLE ALLOWING FOR EASY ACCESS AND LABELED WITH OWNER, END LOCATIONS, FIBER TYPE, AND FIBER COUNT.
8. FIBER CONDUIT SHALL EXTEND INTO THE HANDHOLE 12 TO 18 INCHES WITH THE END TURNED UP AND SEALED TO MINIMIZE WATER ENTERING THE CONDUIT.





FIBER HANDHOLE GROUNDING  
LATERAL HANDHOLE GROUNDING

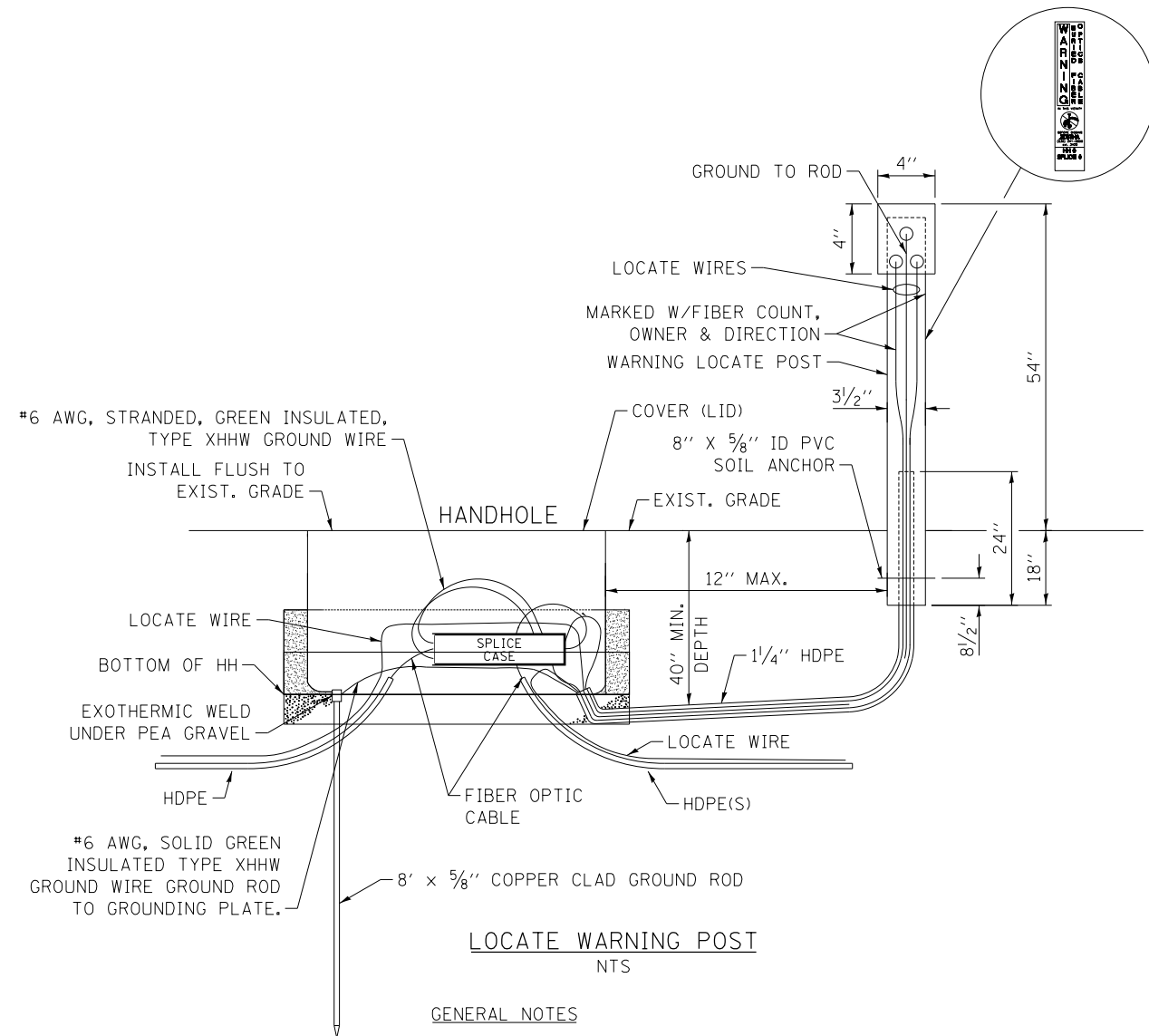

LOCATE WARNING POST  
NTS

GENERAL NOTES

- ROUTE MARKER SHALL BE PLACED 1 FOOT FROM HANDHOLE OR AT FENCE LINE IF POSSIBLE.
- HANDHOLES SHALL BE BACKFILLED ONLY TO THE TOP OF THE BOX, FLUSH TO EXISTING GRADE.
- COIL FIBER CABLE IN HANDHOLE ENSURING THAT THE BEND RADIUS SHALL NOT EXCEED 6".
- INSTALL GROUND ROD & EXOTHERMIC WELD AS PER MANUFACTURER'S INSTRUCTIONS. PLACE THE #6 GROUND WIRE (TYPE XHHW, SOLID, GREEN INSULATED) THAT HAS BEEN ATTACHED TO THE GROUND ROD AND TO THE CENTER LUG OF THE LOCATE POST.
- BACKFILL MATERIAL SHALL BE COMPACTED TO THE SATISFACTION OF THE ENGINEER.
- GROUND WIRE SHALL BE BONDED TO BOTH SHEATHS OF ARMORED FIBER OPTIC CABLE IN THE SPLICE ENCLOSURE USING #6 GROUND STRANDED, GREEN INSULATED WIRE. EACH GROUND SHALL BE ISOLATED WITHIN THE ENCLOSURE.
- INSTALL 1/4" HDPE CONDUIT FROM HANDHOLE TO WARNING POST TO ALLOW GROUNDING CABLE AND LOCATE TRACE WIRES TO BE INSTALLED.
- PLACE 1/4" HDPE OVER FIBER OPTIC CABLE TO PROVIDE CRUSH PROTECTION EXTEND HDPE 1' INSIDE HANDHOLE.
- NO HANDHOLES WILL BE ALLOWED IN PAVED ROADWAYS OR SHOULDERS.
- THE TOPS OF ALL HANDHOLES SHALL BE FLUSH WITH THE EXISTING GRADE.
- HANDHOLE SHALL NOT BE INSTALLED ON STEEP BANKS OR SLOPES WHERE THE COVER CANNOT BE LEVELED WITHIN A TOLERANCE OF ONE INCH (1") OF DROP TO TWELVE INCHES (12") OF GRADE AND REMAIN BURIED.
- A WATER PROOF SEALING SIMPLEX DUCT PLUG SHALL BE INSTALLED AROUND THE FIBER OPTIC TO SEAL AROUND THE CONDUIT. A WATER PROOF SEALING PLUG SHALL BE INSTALLED IN ALL VACANT CONDUIT.
- ANY WORK IN AN EXISTING SINGLE MODE HANDHOLE OR INVOLVING AN EXISTING SINGLE MODE DUCT AND FIBER SHALL BE COORDINATED WITH THE TOLLWAY FIBER OPTIC CONTRACTOR. USING A-36 PROCESS.
- FOR ALL SPLICE AND HANDHOLE, NUMBER DECALS SHALL BE APPLIED AFTER INSTALLATION IS COMPLETED.
- PLACEMENT OF SIGNS IS PREFERRED OVER POSTS. SIGNS SHALL BE USED ON LOCATIONS WHERE FENCE IS VISIBLE FROM ROAD. POSTS SHALL ONLY BE USED WHERE SIGN WOULD NOT BE VISIBLE FROM ROAD.

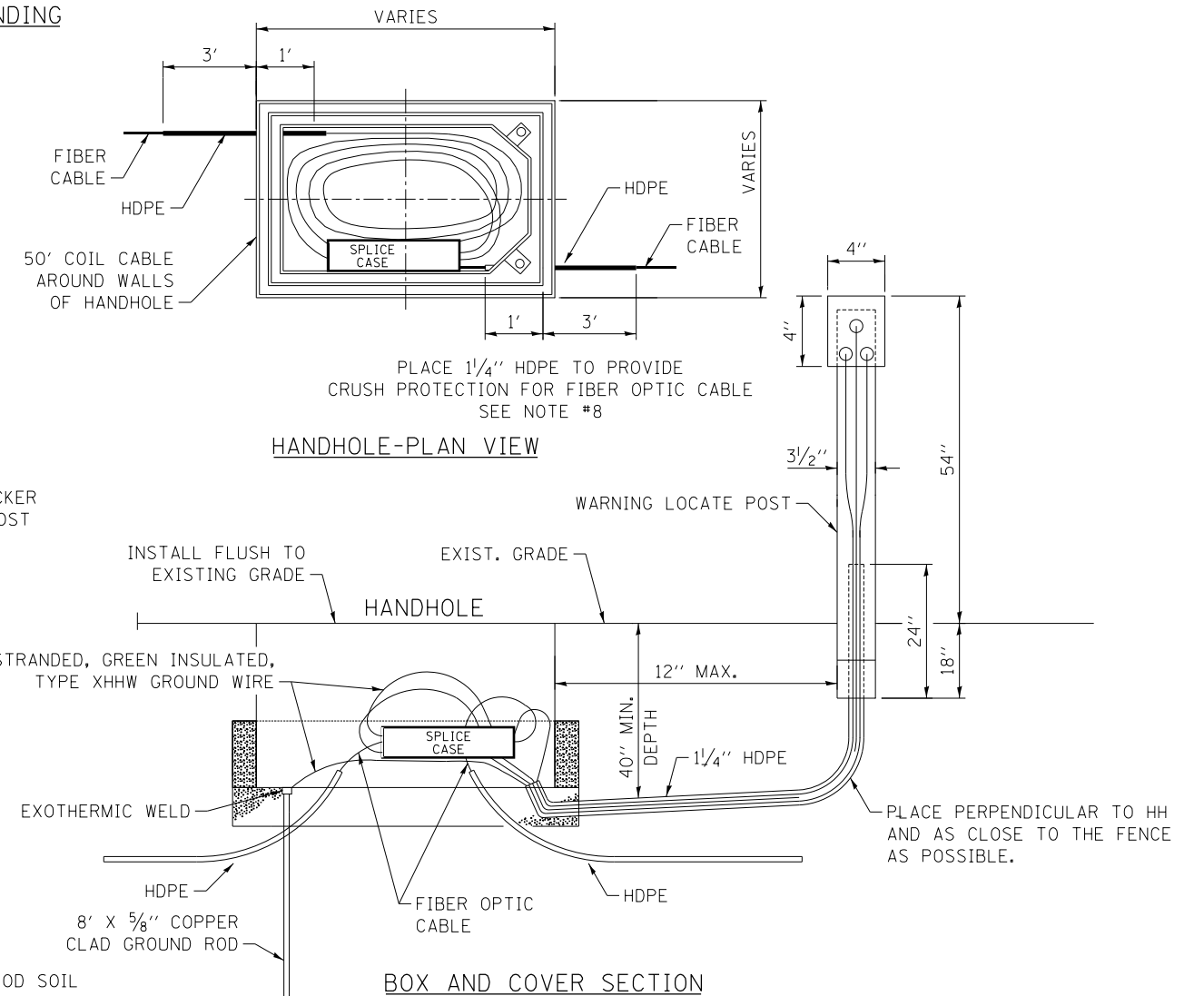

BOX AND COVER SECTION

APPROVED: *Paul Kovacs* CHIEF ENGINEER DATE 3-31-2017



HANDHOLE SPLICE GROUNDING  
THIRD PARTY CONDUIT

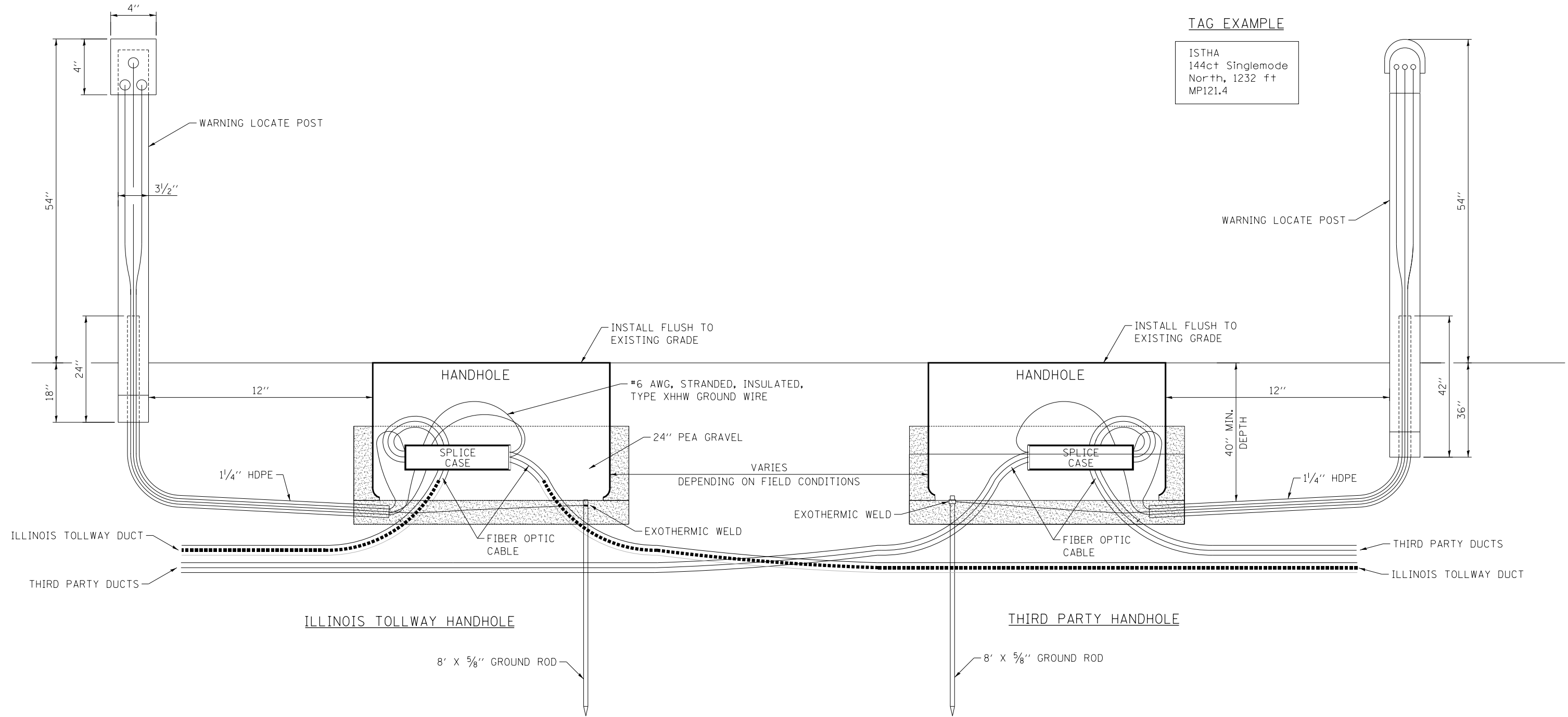

TAG EXAMPLE

ISTHA  
144ct Singlemode  
North, 1232 ft  
MP121.4

NOTES:

- WARNING LOCATE POST SHALL BE PLACED 1 FOOT FROM HANDHOLE OR AT FENCE LINE IF POSSIBLE.
- HANDHOLES SHALL BE BACKFILLED ONLY TO THE TOP OF THE BOX FLUSH TO EXISTING GRADE.
- INSTALL GROUND ROD & EXOTHERMIC WELD AS PER MANUFACTURER'S INSTRUCTIONS. PLACE THE #6 GROUND WIRE (TYPE XHHW, SOLID, GREEN INSULATED) THAT HAS BEEN ATTACHED TO THE GROUND ROD ON THE CENTER LUG OF THE WARNING LOCATE POST.
- GROUND WIRE SHALL BE BONDED TO BOTH SHEATHS OF ARMORED FIBER OPTIC CABLE IN THE SPLICE ENCLOSURE USING #6 STRANDED GREEN INSULATED TYPE XHHW GROUND WIRE. EACH GROUND SHALL BE ISOLATED WITHIN THE ENCLOSURE.
- PLACE 1 1/4" HDPE OVER FIBER OPTIC CABLE TO PROVIDE CRUSH PROTECTION EXTEND HDPE 1' INSIDE HANDHOLE.
- NO HANDHOLES SHALL BE ALLOWED IN PAVED ROADWAYS OR SHOULDERS.
- THE TOPS OF ALL HANDHOLES SHALL BE FLUSH WITH THE EXISTING GRADE UNLESS THE SLOPE IS GREATER THEN 1:4. IF SO, THE HANDHOLE SHALL BE PLACED LEVEL WITH THE EARTH GRADED AROUND IT SO NO PART OF THE SIDES OF THE HANDHOLE IS EXPOSED.
- A WARNING LOCATE POST SHALL BE INSTALLED AT ALL HANDHOLES.
- LOCATE WIRE SHALL BE TESTED FROM HANDHOLE TO HANDHOLE PRIOR TO ANY FIBER BEING INSTALLED IN CONDUIT.
- LOCATE WIRES SHALL BE TAGGED INSIDE LOCATE POST. THE TAG SHALL SHOW THE FIBER OWNER, FIBER COUNT, FIBER TYPE, DIRECTION (N,S,E,W), DISTANCE TO NEXT LOCATE POST, AND MILE POST AT THAT LOCATION.

APPROVED: *Paul Kovacs* CHIEF ENGINEER DATE 3-31-2017



**WALL PENETRATION DETAIL**

NOTE:  
THE MAXIMUM PIPE STRAP SPACING SHALL BE 30" MAX. VERTICAL AND 18" HORIZONTAL MAXIMUM DISTANCE. A MINIMUM OF TWO PIPE STRAPS SHALL BE PLACED FOR ANY CONDUIT PLACED HIGHER THAN 4' ABOVE GRADE.

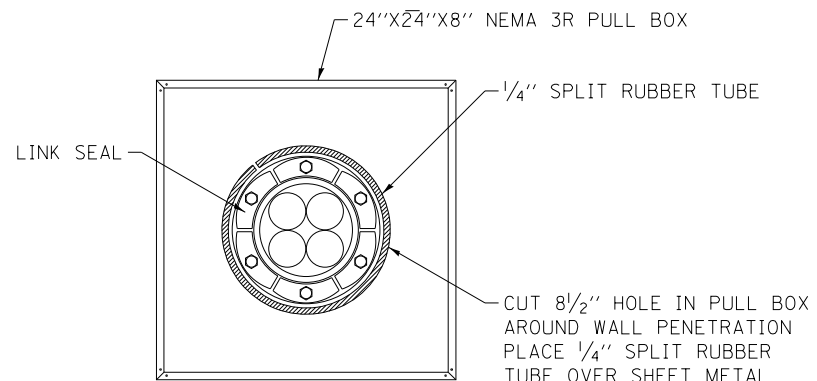

**DETAIL A**  
FRONT VIEW  
BELOW GRADE  
BUILDING ENTRANCE PULL BOX

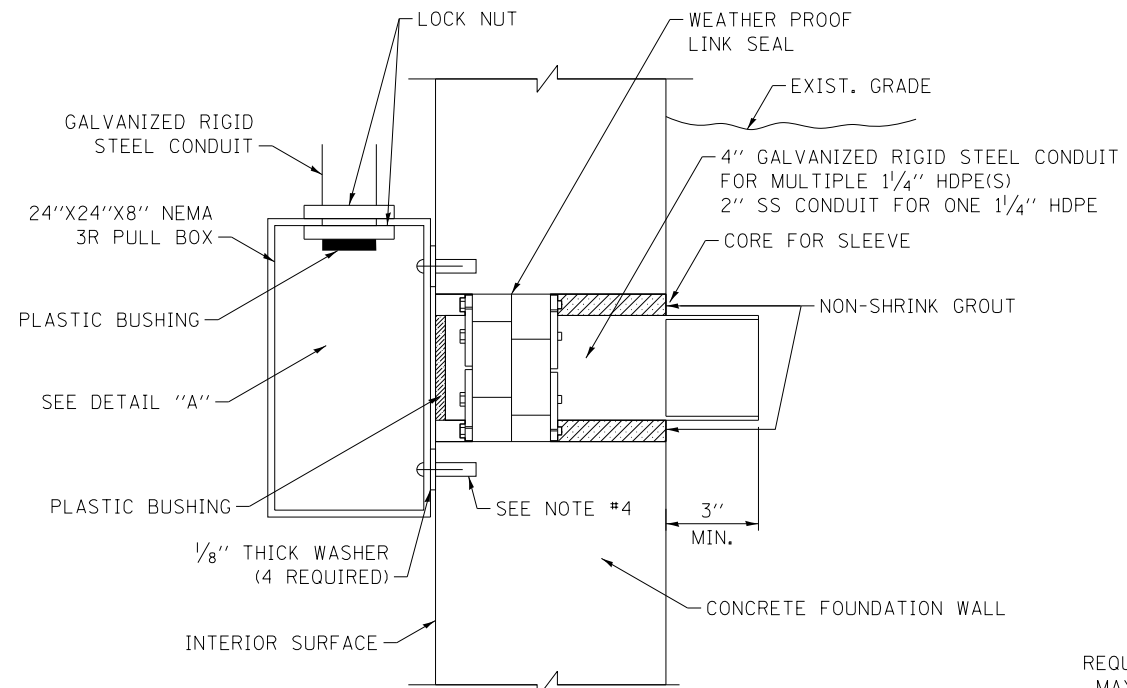

**DETAIL B**  
SIDE VIEW  
BELOW GRADE  
BUILDING ENTRANCE PULL BOX

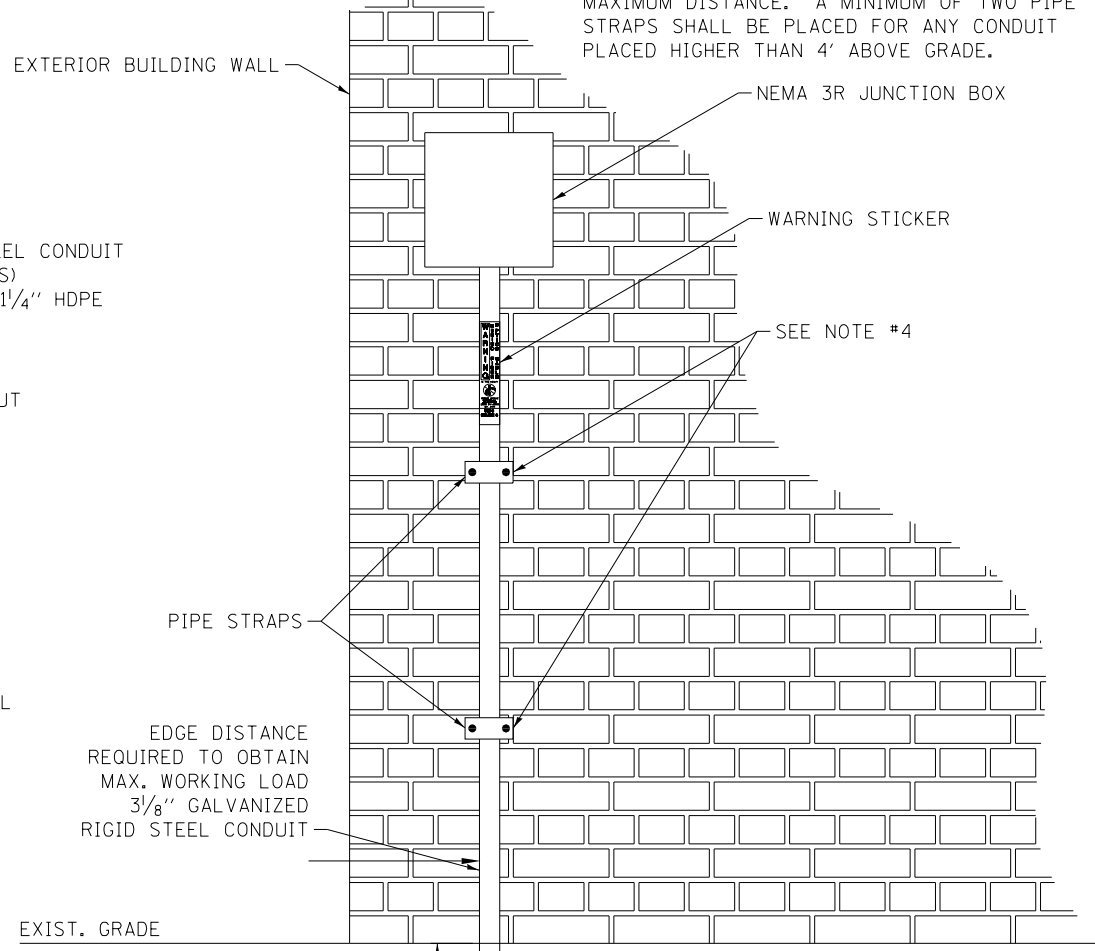

**DETAIL C**  
ABOVE GRADE  
BUILDING ENTRANCE  
CONDUIT

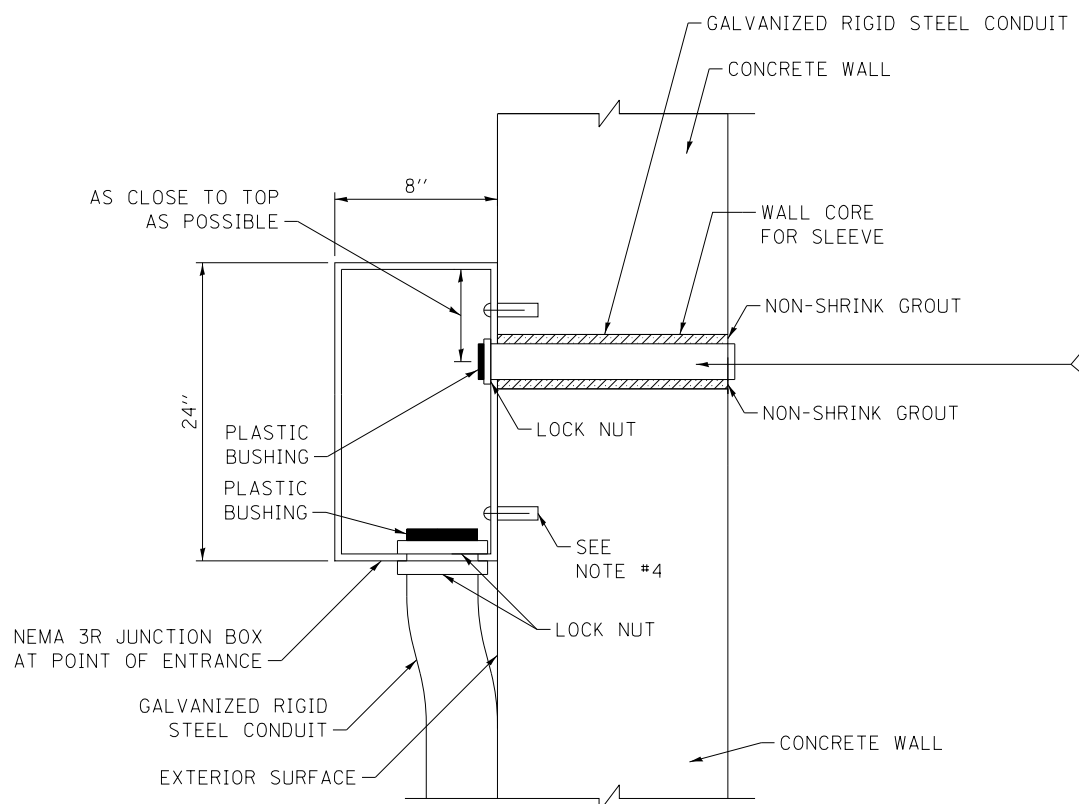

**DETAIL D**  
ABOVE GRADE  
BUILDING ENTRANCE PULL BOX

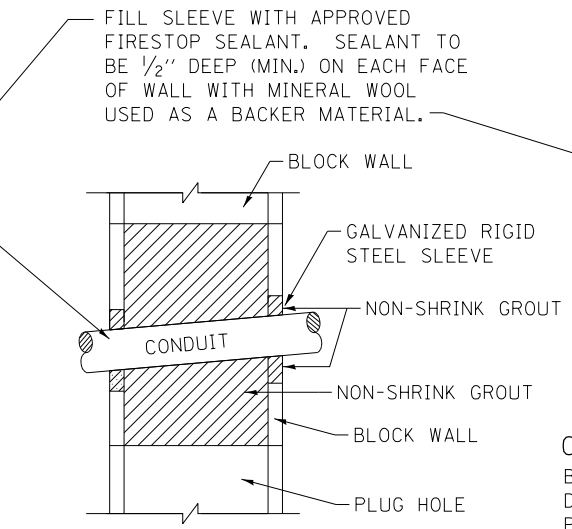

**DETAIL E**  
BLOCK WALL PENETRATION

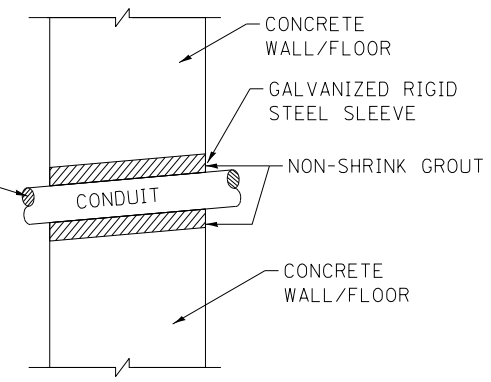

**DETAIL F**  
CONCRETE WALL/FLOOR PENETRATION  
BUILDING PENETRATIONS SPECIFIED AS  
DETAIL F MAY BE A COMBINATION OF  
POURED OR HOLLOW CONCRETE BLOCK  
WITH A BRICK EXTERIOR. IF HOLLOW  
BLOCK IS ENCOUNTERED COMPLETE  
INSTALLATION PER DETAIL E THIS SHEET.

**GENERAL NOTES:**

1. ALL PENETRATIONS SHALL UTILIZE EXISTING UNUSED BUILDING PENETRATIONS TO THE MAXIMUM EXTENT POSSIBLE.
2. ALL EXTERIOR MATERIALS SHALL BE STAINLESS STEEL UNLESS OTHERWISE NOTED.
3. ALL ANCHORS SHALL BE INSTALLED IN SOUND CONCRETE OR MASONRY.
4. USE APPROVED MASONRY ANCHOR.

*Paul Kovacs*  
APPROVED... CHIEF ENGINEER... DATE 3-31-2017...

SHEET 10 OF 15



FIBER OPTIC SYSTEM  
TYPICALS AND DRAWINGS

STANDARD L1-01

UNDERGROUND PENETRATION DETAIL

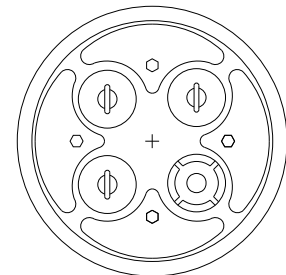

FRONT VIEW  
QUAD DUCT PLUG

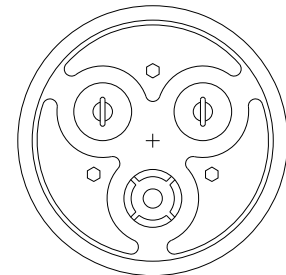

FRONT VIEW  
DUCT PLUG

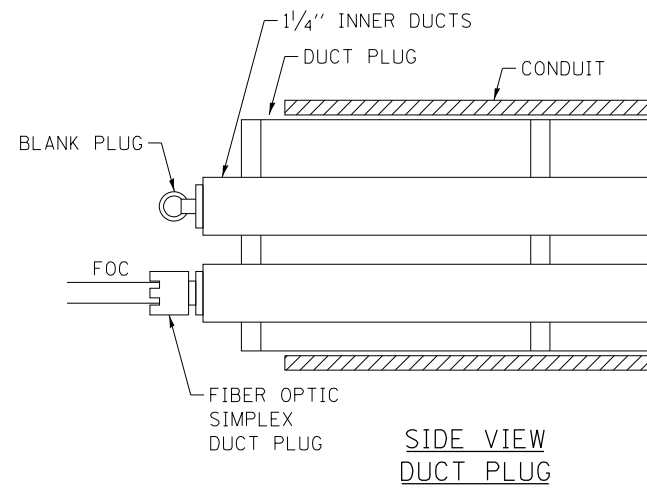

DUCT PLUG DETAIL  
NOT TO SCALE

GENERAL NOTES:

1. GALVANIZED RIGID STEEL CONDUIT EXTENDING THROUGH FOUNDATION WALL SHALL BE ONE CONTINUOUS PIECE (NO COUPLINGS), SQUARE WITH BUILDING AT A SLIGHT ANGLE TO THE EXTERIOR TO PREVENT WATER SEEPAGE.

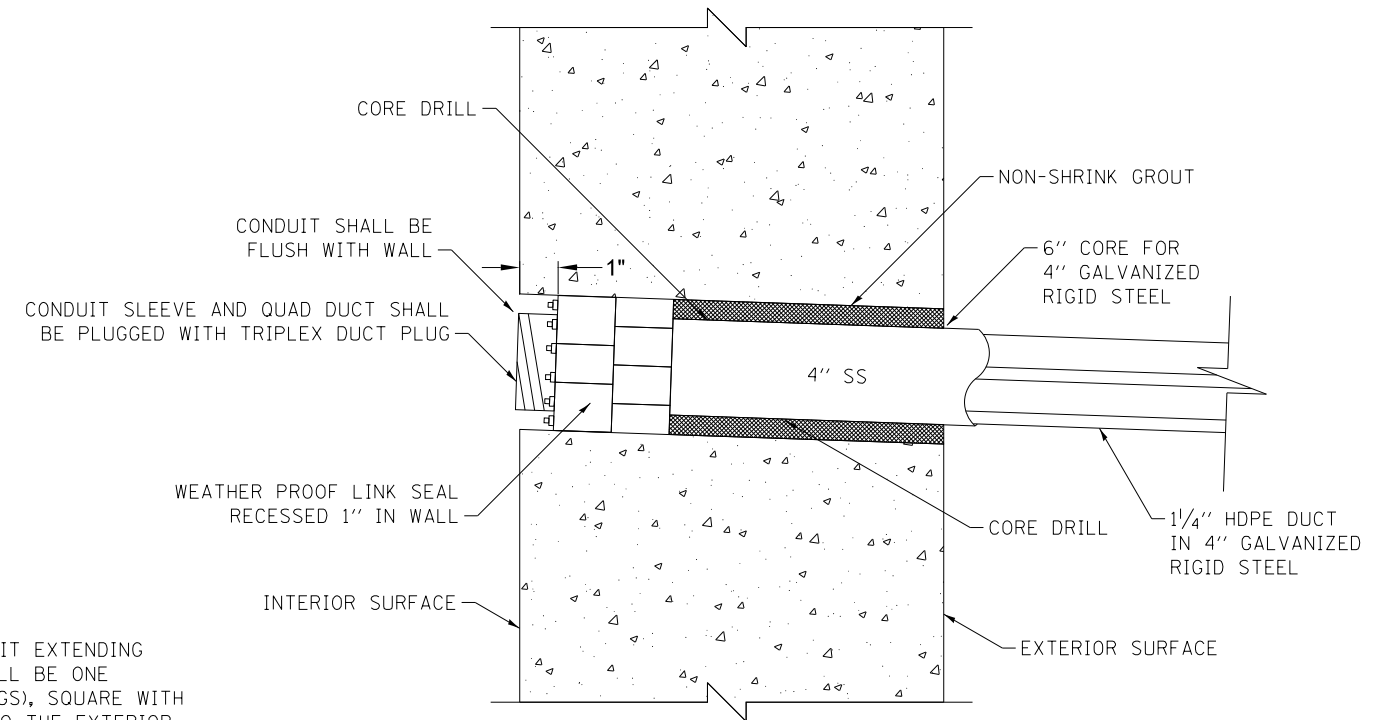

BELOW GRADE PENETRATION BUILDING  
NOT TO SCALE

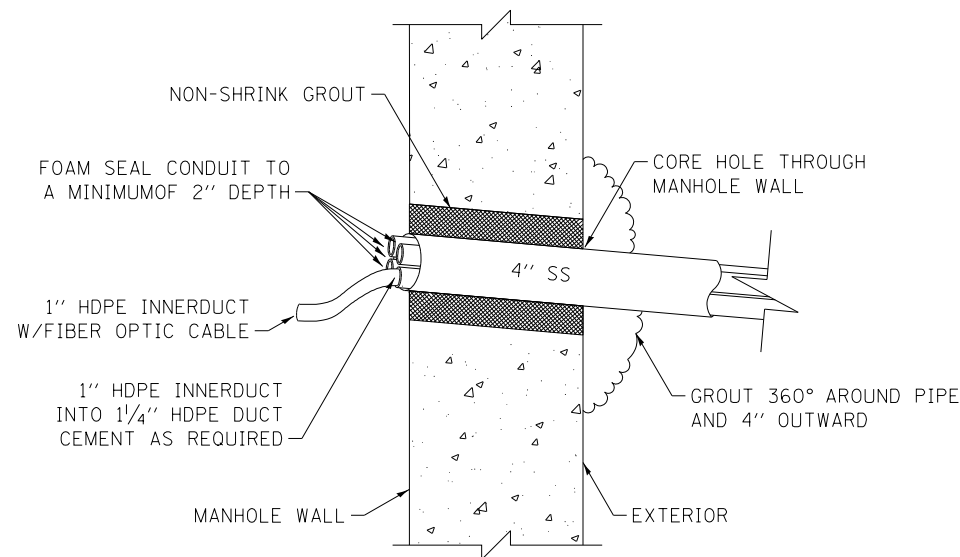

MANHOLE PENETRATION DETAIL  
NOT TO SCALE

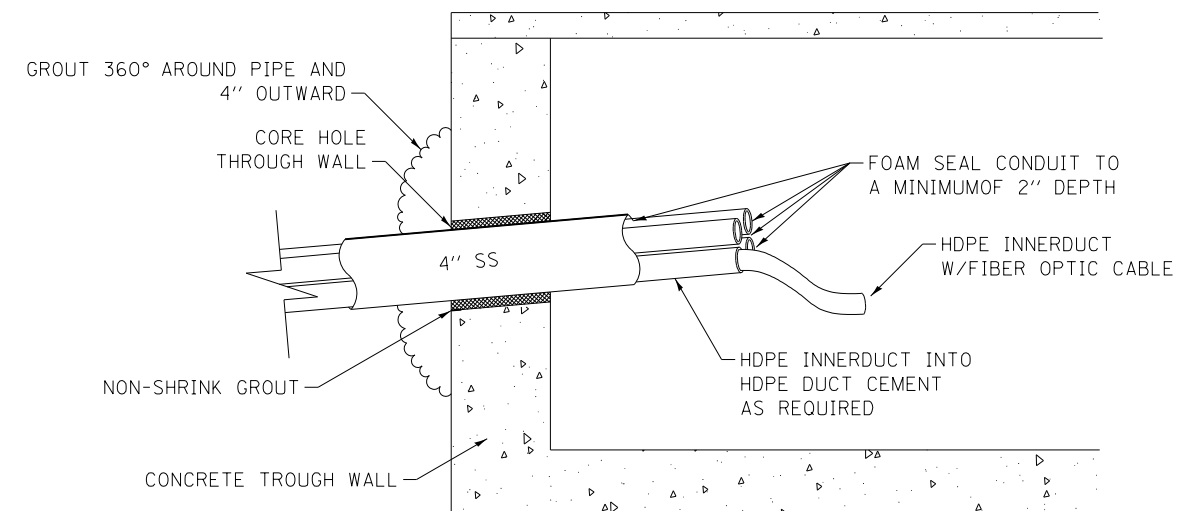

CONCRETE TROUGH PENETRATION  
NOT TO SCALE



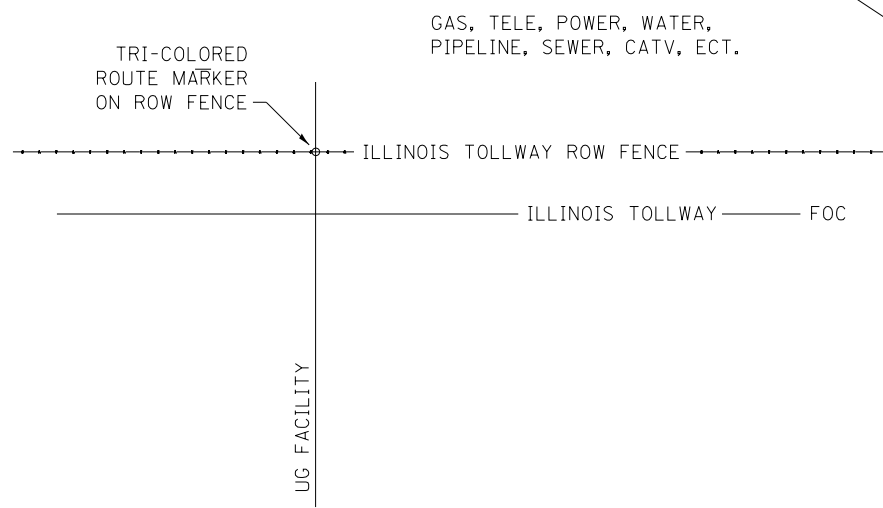

FACILITY CROSSING  
FIG. 1

BURIED CABLE SIGNAGE

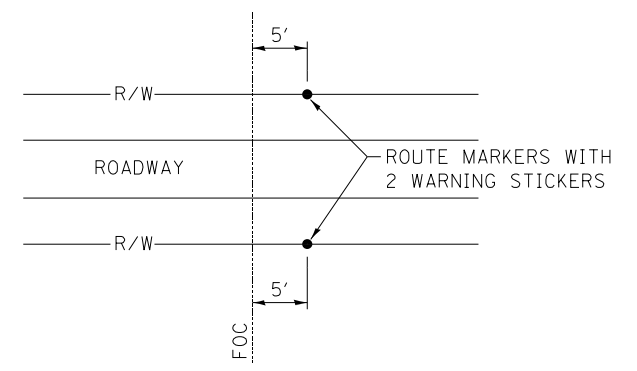

TYPICAL MARKER PLACEMENT AT ROAD AND BRIDGE CROSSING  
FIG. 2

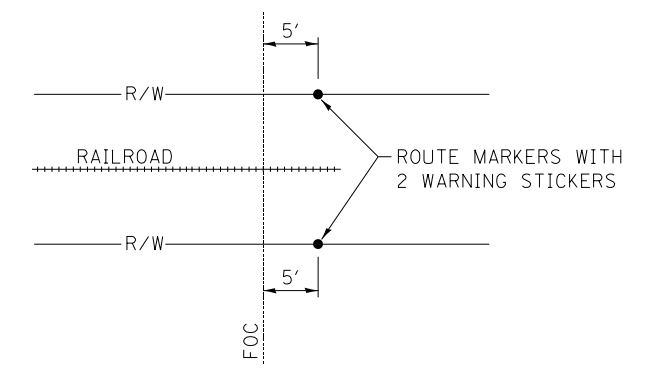

TYPICAL MARKER PLACEMENT AT RAILROAD CROSSING  
FIG. 3

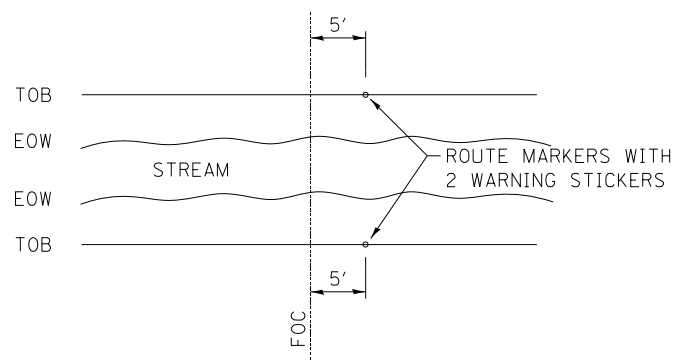

TYPICAL MARKER PLACEMENT AT RIVER,  
CREEK & DRAINAGE DITCH CROSSING  
FIG. 4

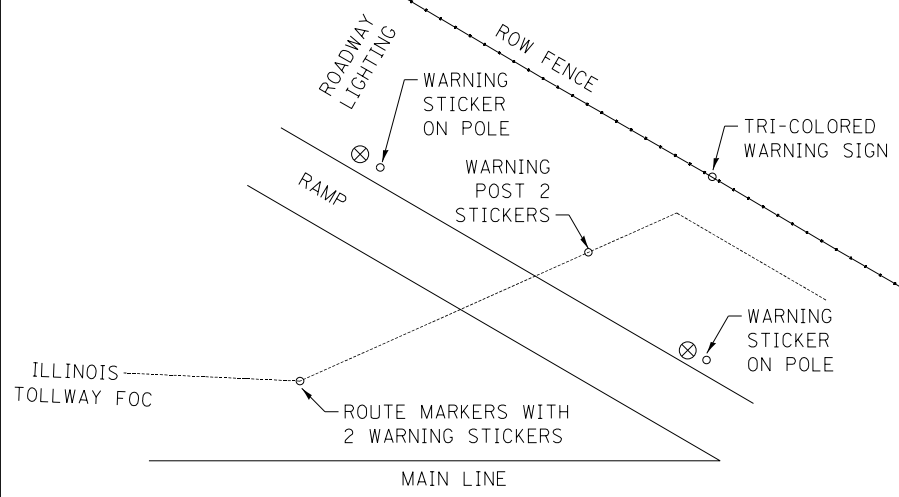

ON/OFF RAMP CROSSING  
FIG. 5

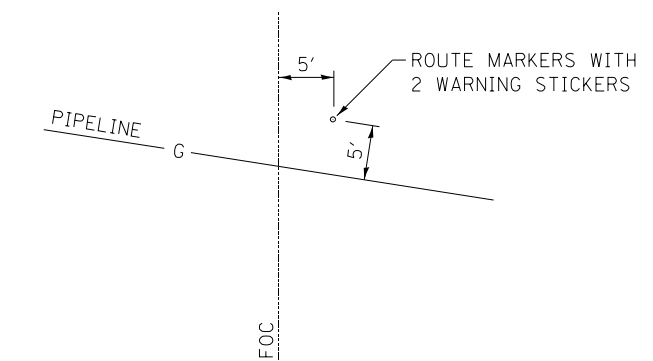

TYPICAL MARKER PLACEMENT AT PIPELINE CROSSING  
FIG. 6

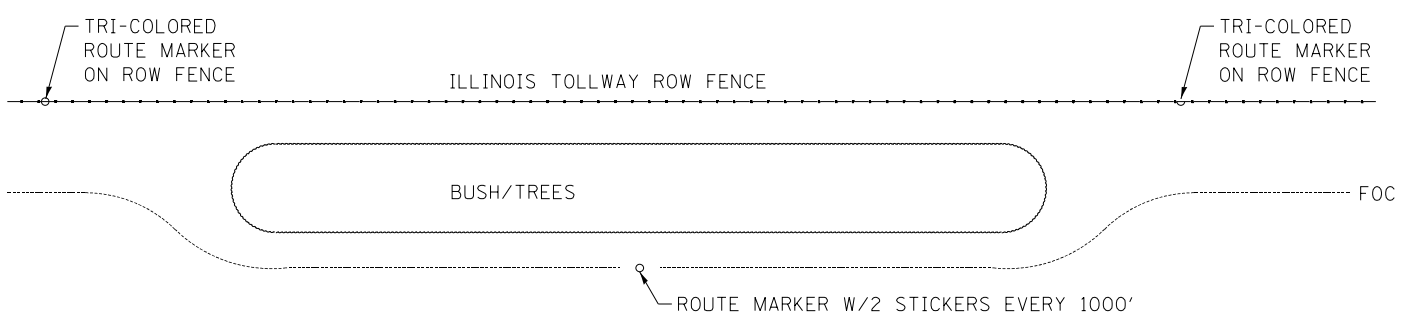
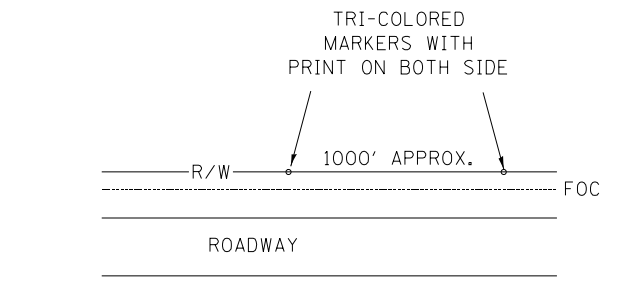

FIG. 7



TYPICAL MARKER PLACEMENT  
TO BE PLACED NEXT TO R.O.W. FENCE LINE  
FIG. 8

GENERAL NOTES:

1. MAINTAIN A MINIMUM DISTANCE OF 5' FROM ANY UTILITY POLE OR PEDESTAL SIGN, MARKER POLE, OR ANY OTHER STRUCTURE.
2. WARNING MARKERS SHALL BE PLACED AT 1000' INTERVALS AND AT CHANGES IN CABLE LOCATION/DIRECTION OR TO MARK THE LOCATION OF HANDHOLES OR AT CROSSING POINT OF OTHER UNDERGROUND FACILITIES. THE CONTRACTOR SHALL ADJUST EXCAVATION AS NECESSARY TO AVOID HIDDEN OBSTACLES AND TO MAINTAIN MAXIMUM DISTANCE FROM THE EDGE OF PAVEMENT. ALL DEVIATIONS SHALL BE APPROVED BY THE ENGINEER.



ROUTE MARKER INSTALLATION PROCEDURE

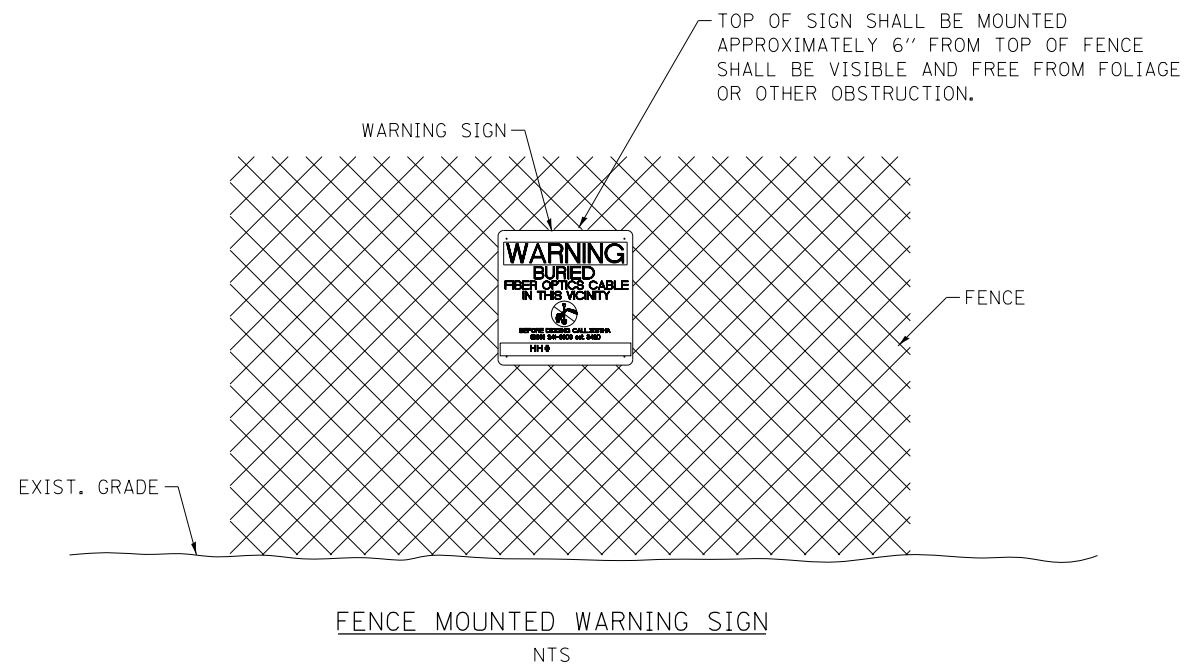

INSTALLATION OF WARNING POST:

1. INSTALL WARNING POST ACCORDING TO MANUFACTURERS INSTRUCTIONS AND RECOMMENDATIONS.
2. PLACEMENT OF POST SHALL NOT INTERFERE WITH THE REMOVAL OF HANDHOLE LIDS
3. WARNING SIGN SHALL BE ATTACHED TO ROW FENCE WHEREVER POSSIBLE. UV STABILIZED BLACK NYLON CABLE TIES (14" LENGTH, 0.30" WIDTH, 120 LBS TENSILE STRENGTH), (4 EA.) 3 WRAPS EACH TIE, SHALL BE USED TO ATTACH WARNING SIGN TO FENCE.
4. SEE SHEET 14 OF THIS SERIES FOR FIBER WARNING LABEL AND WARNING SIGN DETAILS.

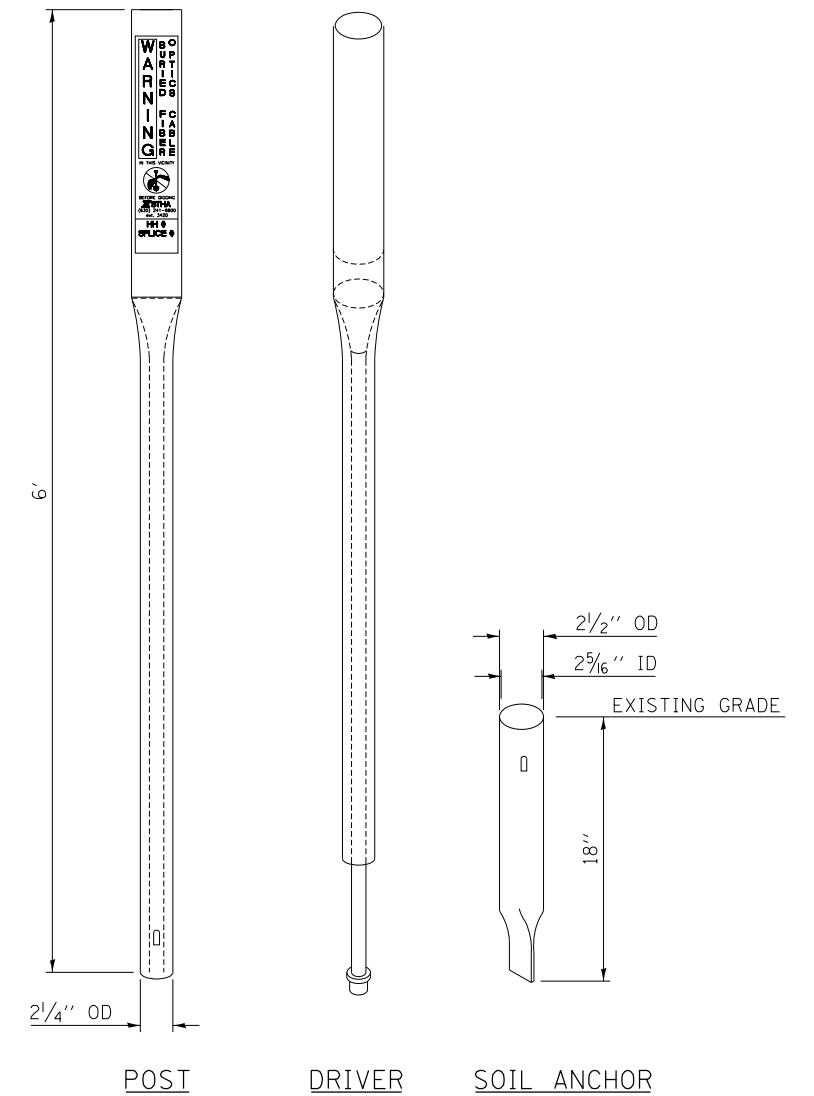

FIBER WARNING LABEL & WARNING SIGN DETAILS



FENCE SIGN

Part #: SA-ISTHA  
 Size: 12" T X 9" W  
 Material: Polyethylene  
 Color: Black text with Orange bkgd, with white  
 Holes: 4 - 3/16"



Products provided by:



Part #: PP6-ISTHA  
 Size: 6"  
 Material: Polydome  
 Color: Orange Post and dome

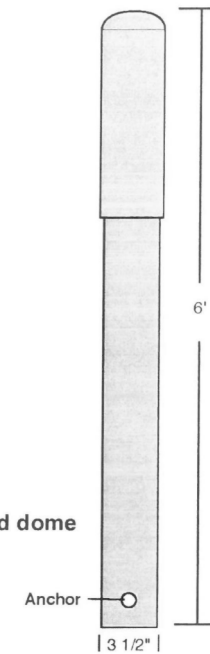

ROUTE MARKER POST

ROUTE MARKER POST DECAL



Part #: PTP466000-ISTHA - 4" X 6,000', 6MIL Orange with black text

WARNING TAPE



FLUSH DISC MARKER

Part #: FMM-6-ISTHA  
 Size: 6"  
 Material: Clear .125 Lexan  
 Color: Black text with Orange bkgd  
 Holes: center for 12.5 plastic anchor

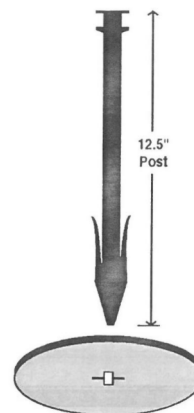

Part #: D-314-ISTHA  
 Size: 14" x 3"  
 Material: Decal  
 Color: Orange with black text, Black "Warning" panel with white text, White no dig  
 Scale: Shown @ 50%

NOTE:  
 SIGN AND LABEL SHOWN IS AVAILABLE THROUGH ACP INTERNATIONAL.  
 ALTERNATE SIGN LABELS SHALL BE SUBMITTED FOR APPROVAL BY THE ENGINEER.

*Paul Kovacs*  
 APPROVED..... CHIEF ENGINEER..... DATE 3-31-2017.....



# 48" X 72" HANDHOLE ASSEMBLY

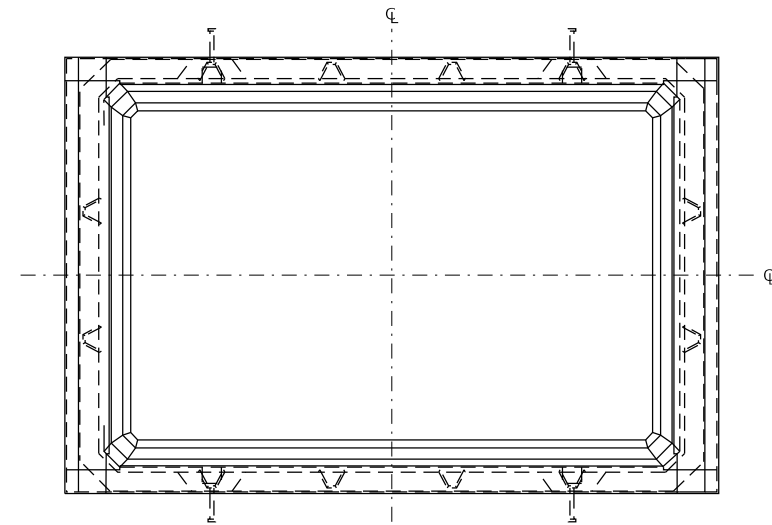

**TOP VIEW**

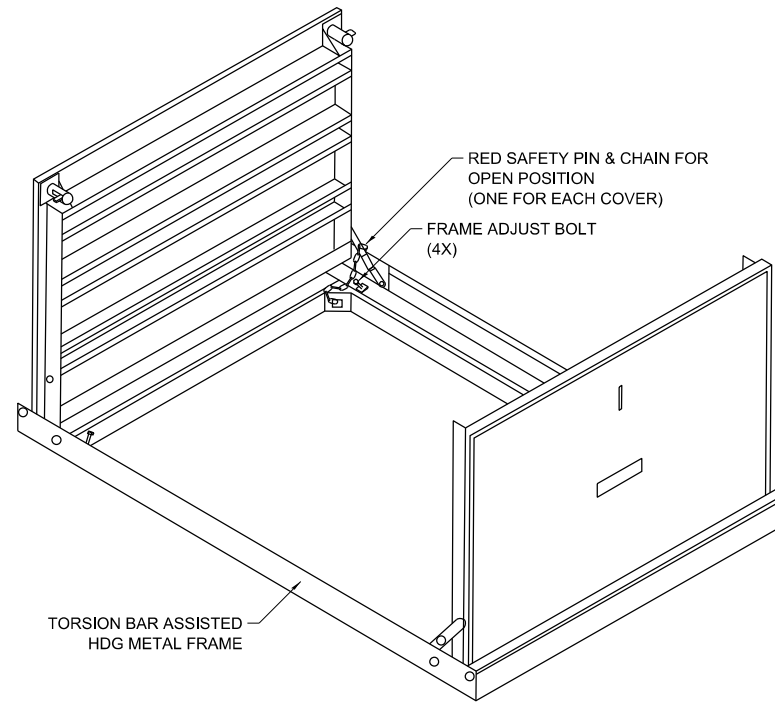

**TORSION ASSIST COVER**

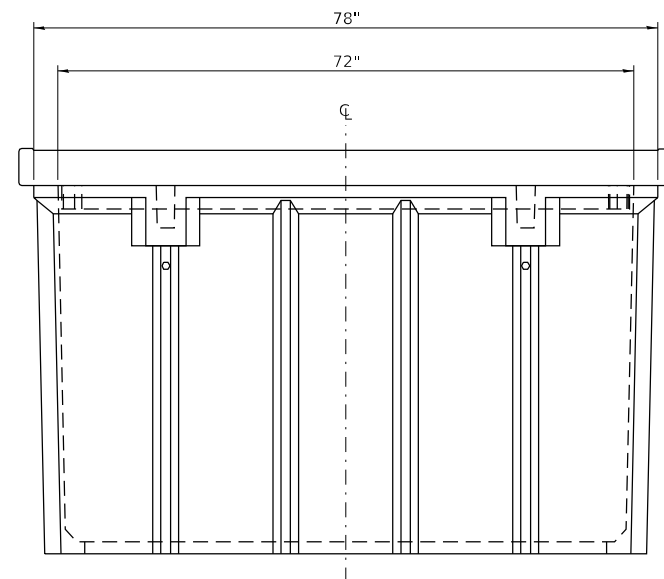
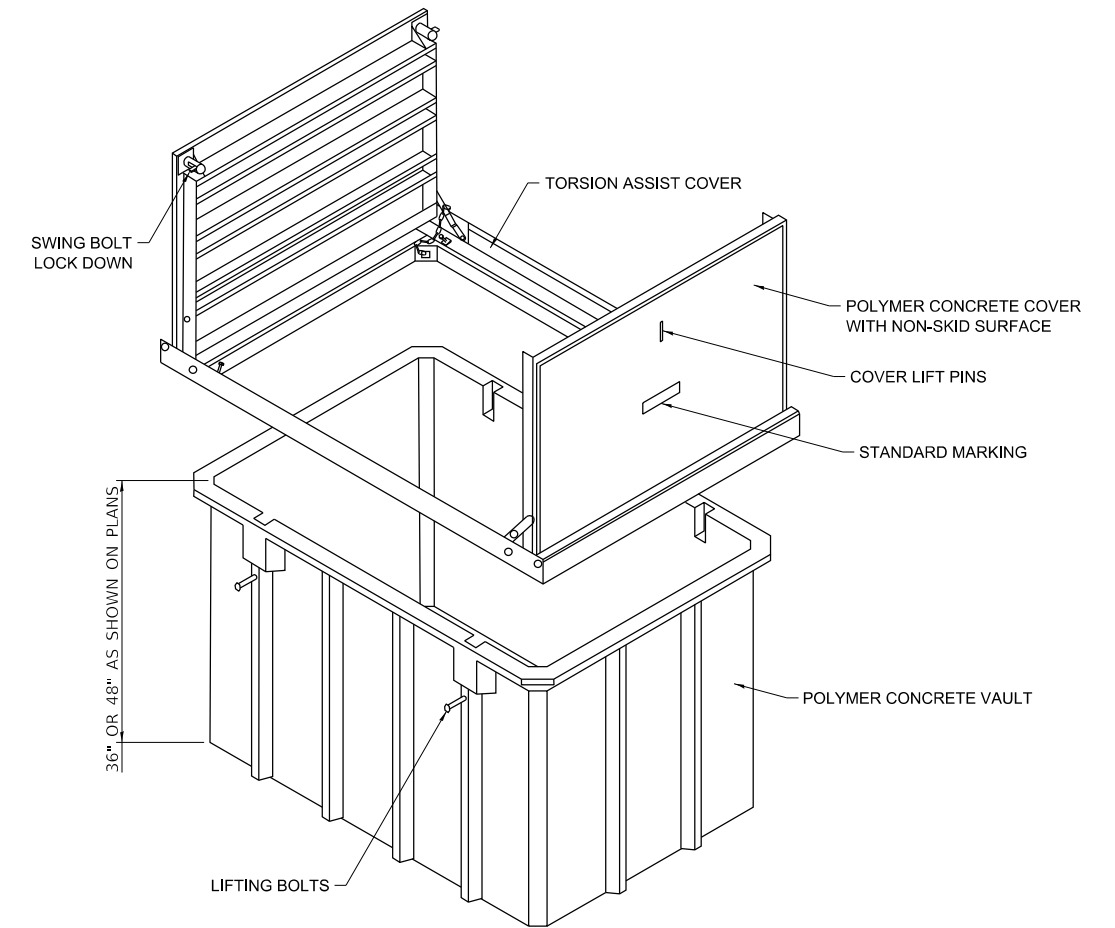

**SIDE VIEW**

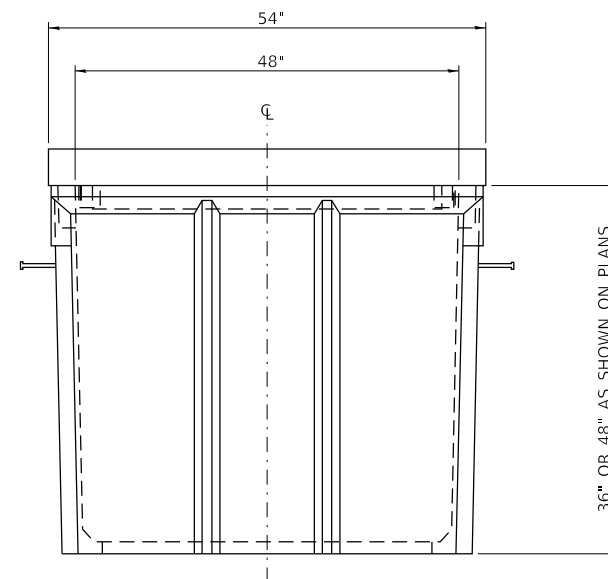

**END VIEW**

**NOTE:**

- 1) FIBER OPTIC CABLES MUST HAVE A CABLE I.D. TAG ON BOTH SIDES OF THE SLACK COIL IDENTIFYING THE OWNER, CABLE COUNT, AND DIRECTION.

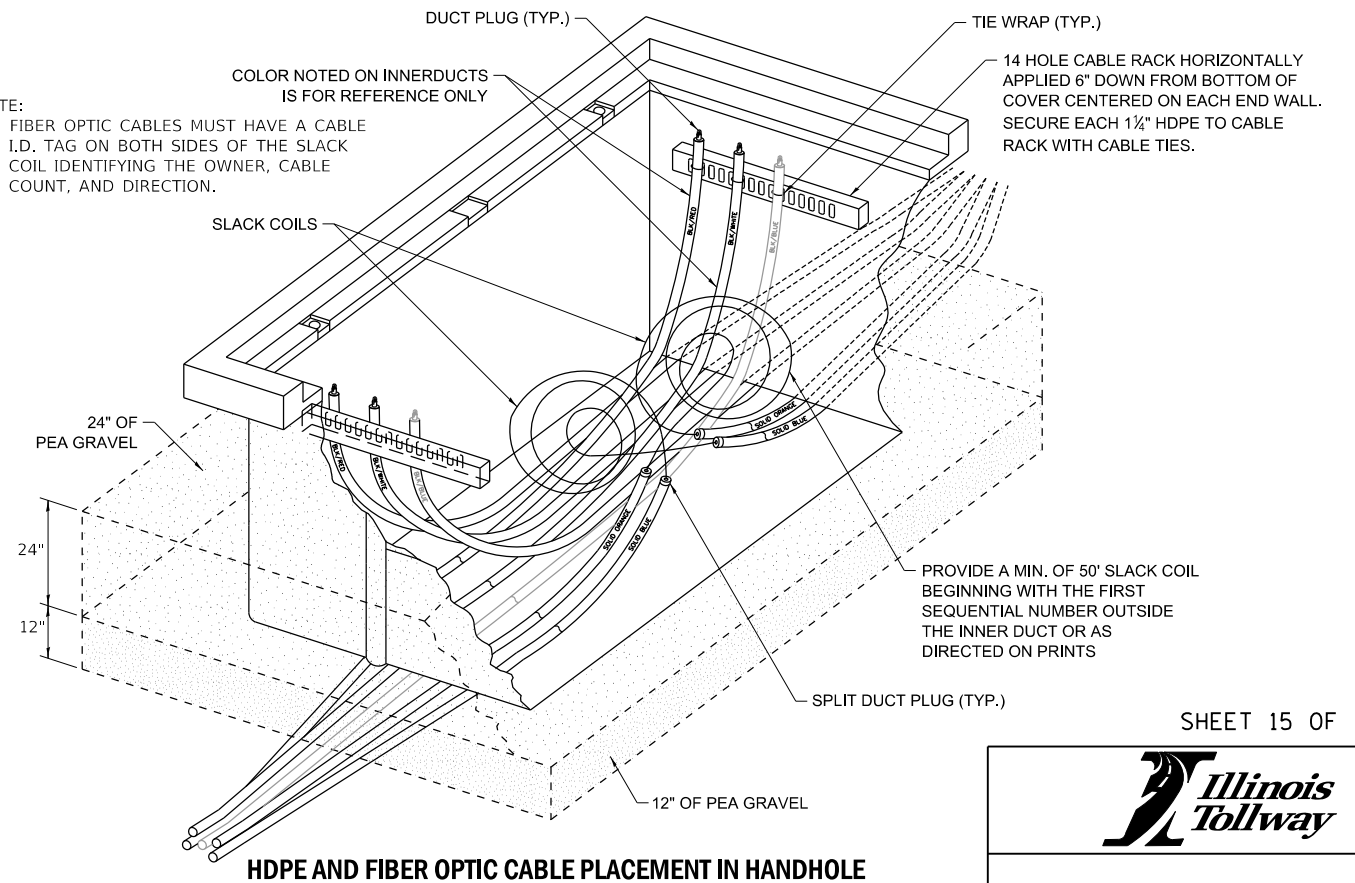



144 SMFO ITS COMMUNICATIONS CABLE  
TO NEXT UPSTREAM ITS DEVICE CABINET

CCTV & CO-LOCATED DEVICE CABINET  
SPLICING DETAILS

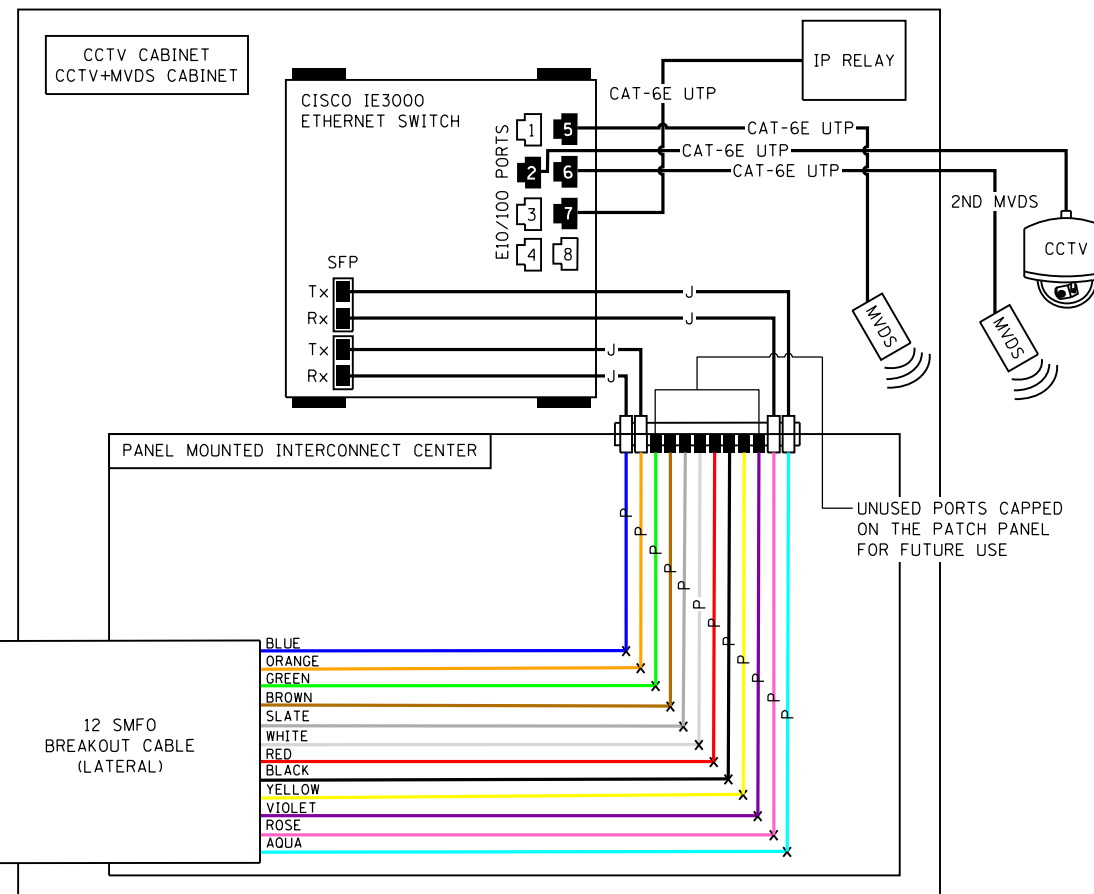
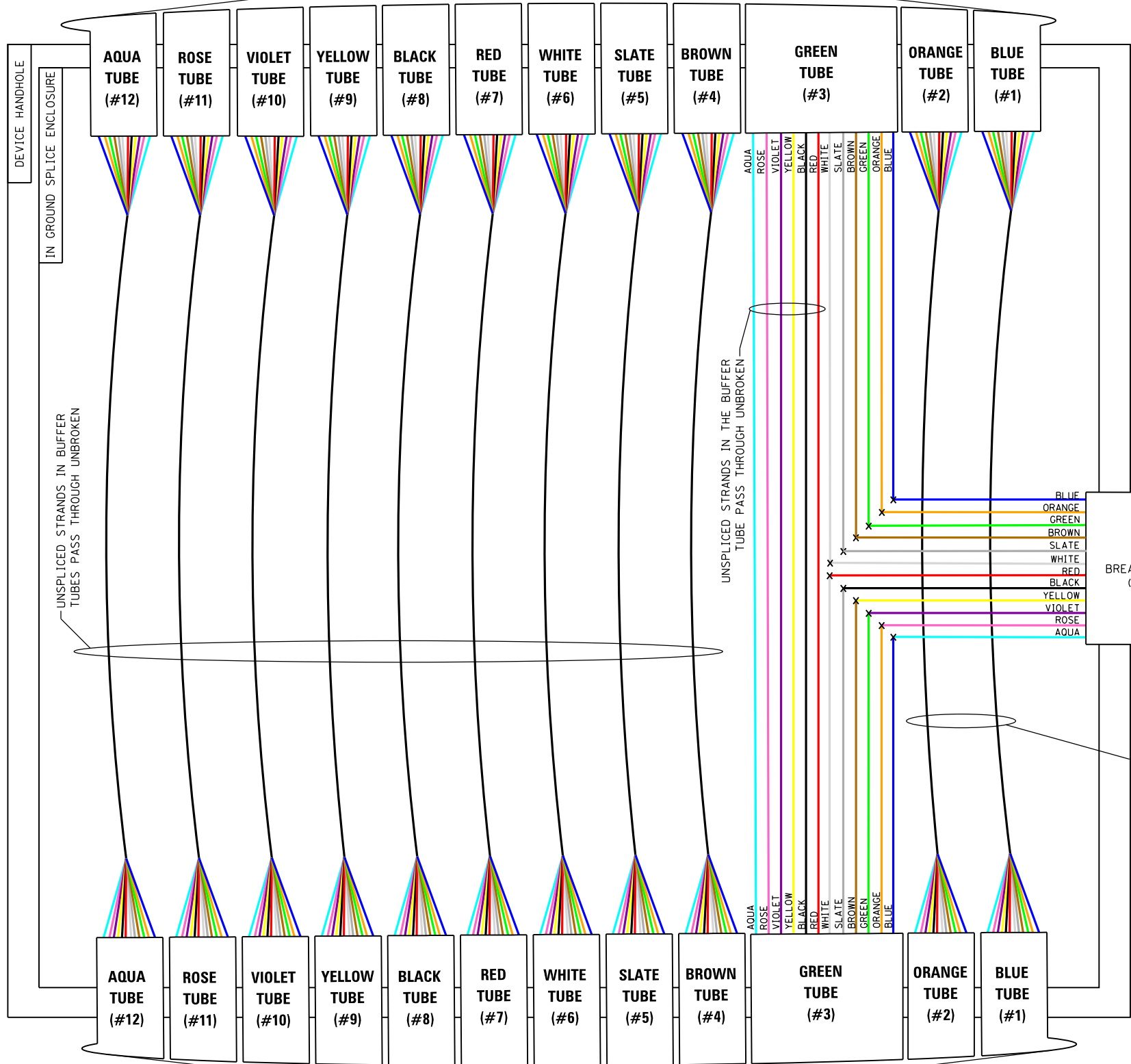

ITS DEVICE GROUP FIBER ASSIGNMENTS (144 SMFO ITS COMMUNICATIONS CABLE)

BUFFER TUBE #1 (BLUE)	- PRIMARY INFRASTRUCTURE SUBGROUP
BUFFER TUBE #2 (ORANGE)	- SECONDARY INFRASTRUCTURE SUBGROUP
BUFFER TUBE #3 (GREEN)	- CCTV & CO-LOCATED ITS DEVICES SUBGROUP (LOCAL FIELD DEVICES)
BUFFER TUBE #4 (BROWN)	- DMS (TYPE 1 & TYPE 2) SUBGROUP (LOCAL FIELD DEVICES)
BUFFER TUBE #5 (SLATE)	- MVDS SUBGROUP (LOCAL FIELD DEVICES)
BUFFER TUBE #6 (WHITE)	- RWIS & WIM SUBGROUP (LOCAL FIELD DEVICES)

**LEGEND**

- FIBER OPTIC JUMPER, SINGLE MODE
- FIBER OPTIC PIGTAIL, SINGLE MODE
- BARE FIBER LEFT COILED IN SPLICE TRAY
- FIBER OPTIC FUSION SPLICE
- FIBER PATCH PANEL, SC CONNECTORS

- NOTES:**
- CONTRACTOR SHALL COORDINATE WITH THE ENGINEER AND THE ILLINOIS TOLLWAY FIBER OPTIC MANAGER FOR FINAL PORT ASSIGNMENTS DURING INSTALLATION AND INTEGRATION.
  - CONTRACTOR SHALL LABEL ALL NETWORK SWITCHES, DATA CABLES, FIBER OPTIC CABLES AND JUMPERS AS PER THE LATEST ILLINOIS TOLLWAY "ITS LABELING GUIDELINE".
  - CONTRACTOR SHALL MAKE ALL NETWORK SWITCH CONNECTIONS, UNLESS OTHERWISE NOTED.
  - THE COLOR VERSION OF THE L2 STANDARD DRAWINGS ARE AVAILABLE ON THE ILLINOIS TOLLWAY WEBSITE.



DATE	REVISIONS

FIBER OPTIC  
SPLICING DETAILS

STANDARD L2-00

*Paul Kovacs*  
APPROVED CHIEF ENGINEER DATE 3-31-2017

144 SMFO ITS COMMUNICATIONS CABLE  
TO NEXT DOWNSTREAM ITS DEVICE CABINET

144 SMFO ITS COMMUNICATIONS CABLE  
TO NEXT UPSTREAM ITS DEVICE CABINET

DMS CABINET SPLICING DETAILS

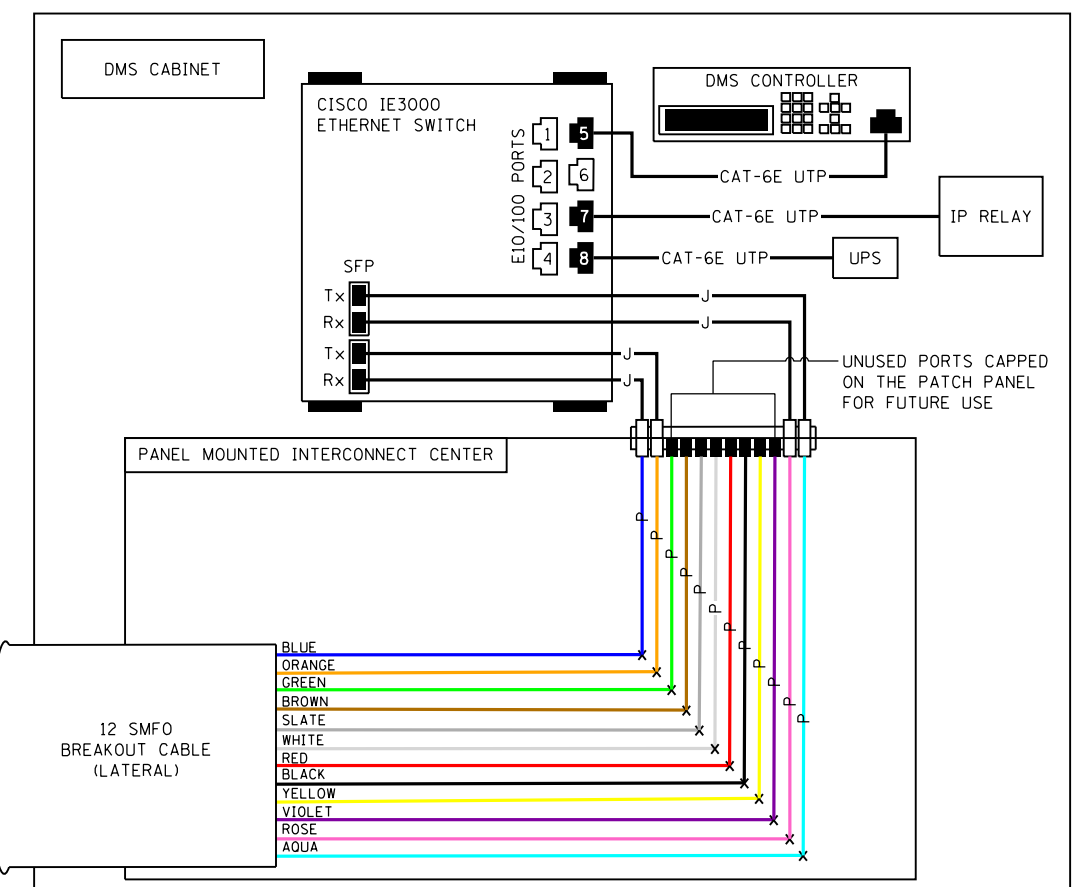
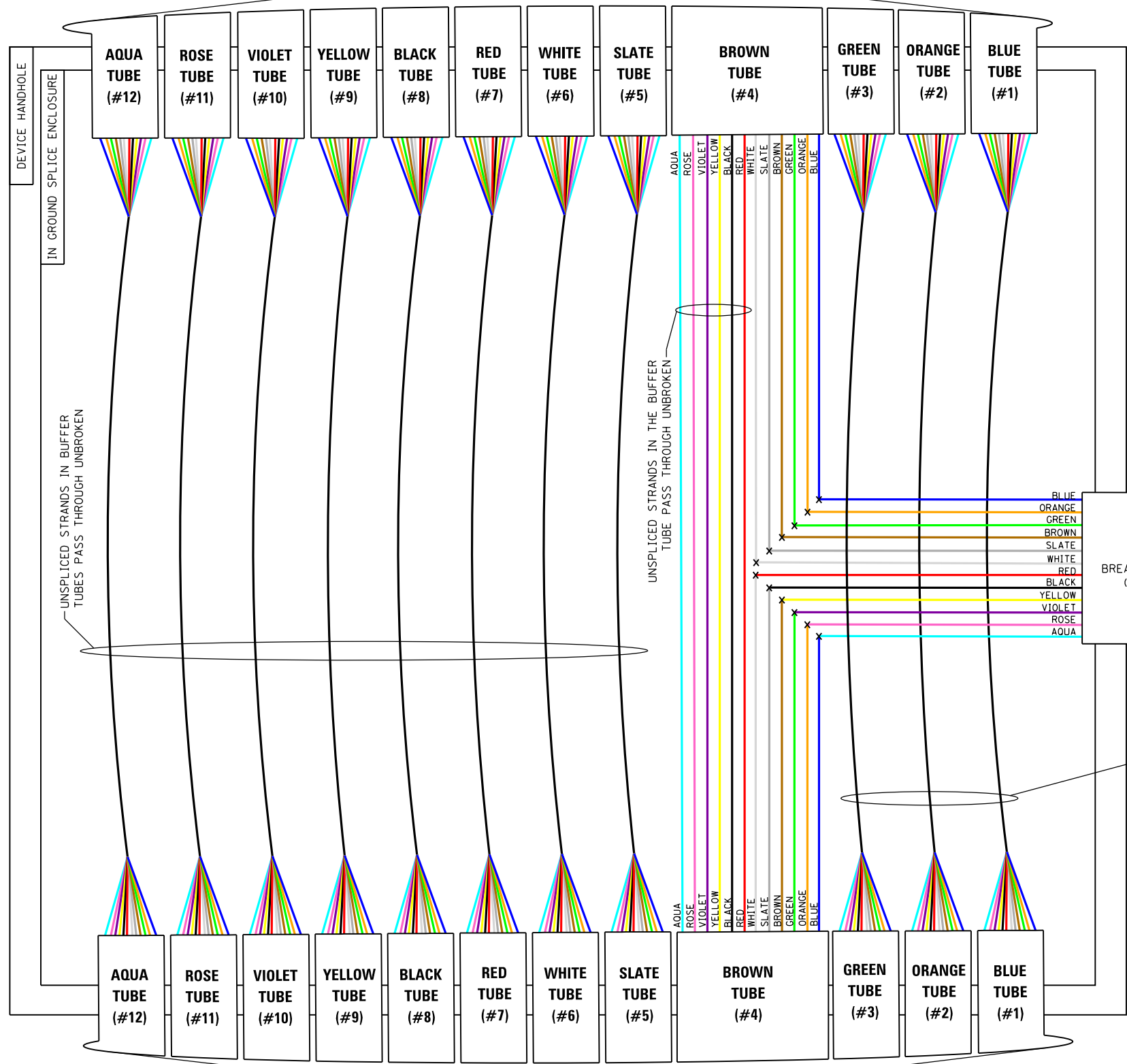

ITS DEVICE GROUP FIBER ASSIGNMENTS (144 SMFO ITS COMMUNICATIONS CABLE)

BUFFER TUBE #1 (BLUE)	- PRIMARY INFRASTRUCTURE SUBGROUP
BUFFER TUBE #2 (ORANGE)	- SECONDARY INFRASTRUCTURE SUBGROUP
BUFFER TUBE #3 (GREEN)	- CCTV & CO-LOCATED ITS DEVICES SUBGROUP (LOCAL FIELD DEVICES)
BUFFER TUBE #4 (BROWN)	- DMS (TYPE 1 & TYPE 2) SUBGROUP (LOCAL FIELD DEVICES)
BUFFER TUBE #5 (SLATE)	- MVDS SUBGROUP (LOCAL FIELD DEVICES)
BUFFER TUBE #6 (WHITE)	- RWIS & WIM SUBGROUP (LOCAL FIELD DEVICES)

**LEGEND**

- FIBER OPTIC JUMPER, SINGLE MODE
- FIBER OPTIC PIGTAIL, SINGLE MODE
- BARE FIBER LEFT COILED IN SPLICE TRAY
- FIBER OPTIC FUSION SPLICE
- FIBER PATCH PANEL, SC CONNECTORS

NOTE:  
SEE SHEET 1 OF 7 FOR NOTES.

APPROVED: *Paul Kovacs*  
CHIEF ENGINEER DATE 3-31-2017

144 SMFO ITS COMMUNICATIONS CABLE  
TO NEXT DOWNSTREAM ITS DEVICE CABINET

SHEET 2 OF 7

FIBER OPTIC  
SPLICING DETAILS

STANDARD L2-00

144 SMFO ITS COMMUNICATIONS CABLE  
TO NEXT UPSTREAM ITS DEVICE CABINET

MVDS CABINET SPLICING DETAILS

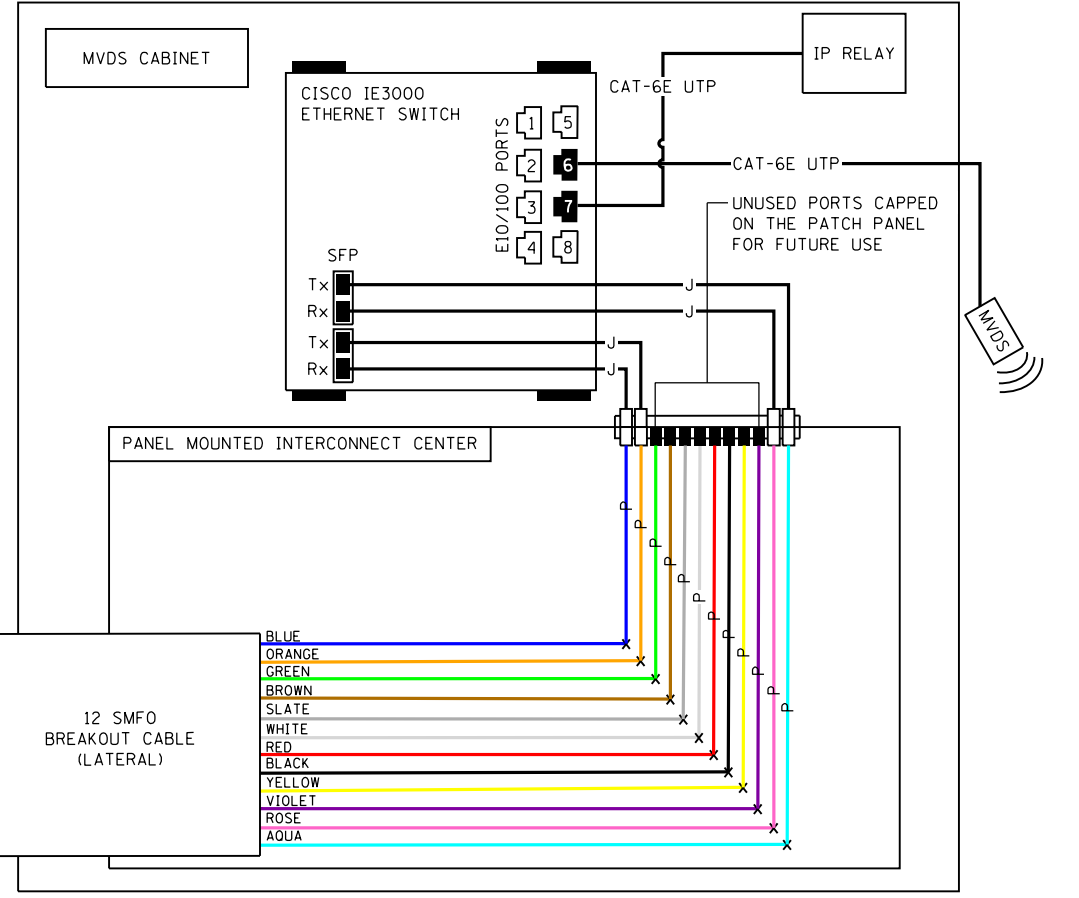
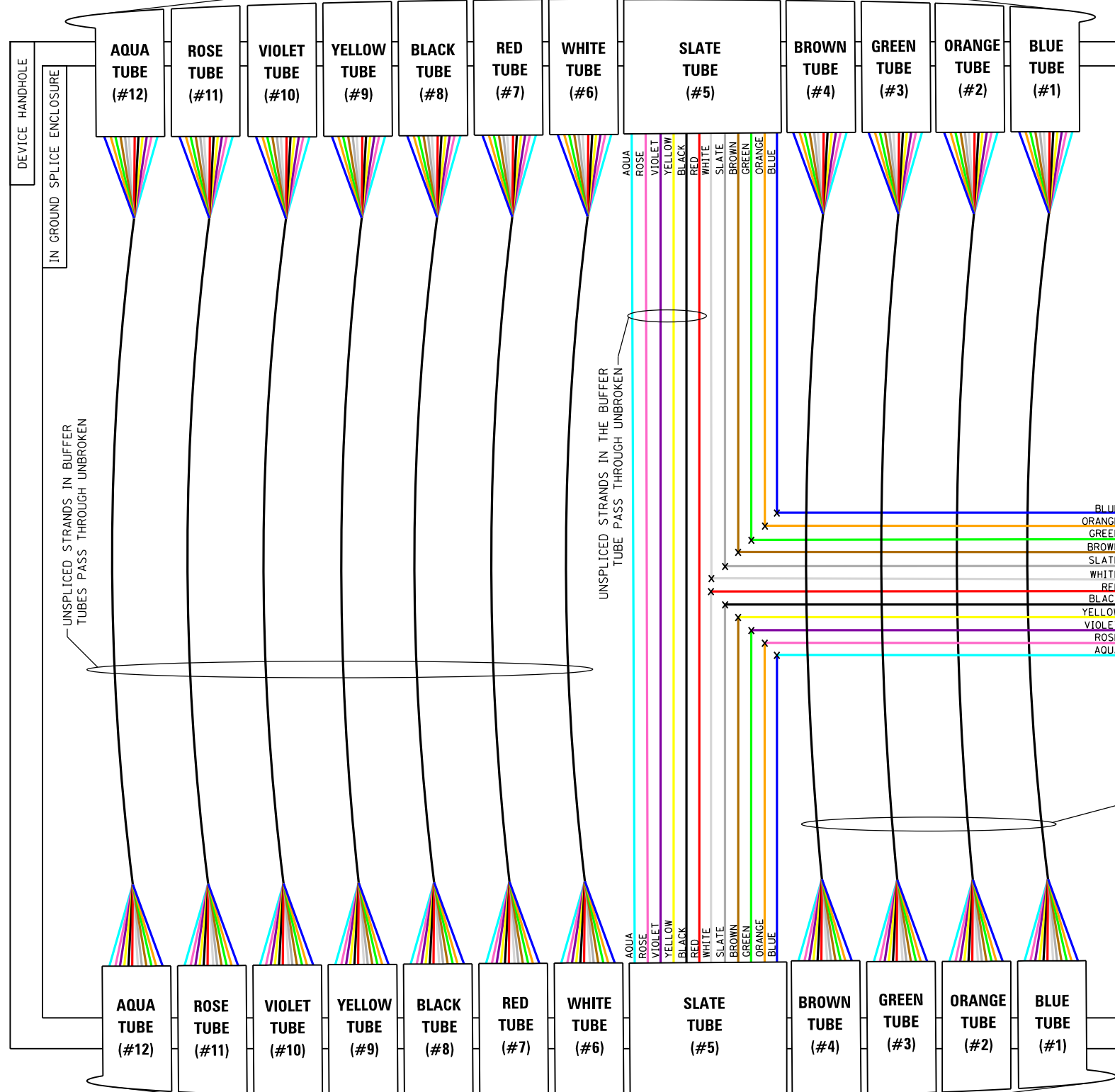

ITS DEVICE GROUP FIBER ASSIGNMENTS (144 SMFO ITS COMMUNICATIONS CABLE)

BUFFER TUBE #1 (BLUE)	- PRIMARY INFRASTRUCTURE SUBGROUP
BUFFER TUBE #2 (ORANGE)	- SECONDARY INFRASTRUCTURE SUBGROUP
BUFFER TUBE #3 (GREEN)	- CCTV & CO-LOCATED ITS DEVICES SUBGROUP (LOCAL FIELD DEVICES)
BUFFER TUBE #4 (BROWN)	- DMS (TYPE 1 & TYPE 2) SUBGROUP (LOCAL FIELD DEVICES)
BUFFER TUBE #5 (SLATE)	- MVDS SUBGROUP (LOCAL FIELD DEVICES)
BUFFER TUBE #6 (WHITE)	- RWIS & WIM SUBGROUP (LOCAL FIELD DEVICES)

**LEGEND**

- FIBER OPTIC JUMPER, SINGLE MODE
- FIBER OPTIC PIGTAIL, SINGLE MODE
- BARE FIBER LEFT COILED IN SPLICE TRAY
- FIBER OPTIC FUSION SPLICE
- FIBER PATCH PANEL, SC CONNECTORS

NOTE:  
SEE SHEET 1 OF 7 FOR NOTES.

*Paul Kovacs*  
APPROVED CHIEF ENGINEER DATE 3-31-2017

144 SMFO ITS COMMUNICATIONS CABLE  
TO NEXT DOWNSTREAM ITS DEVICE CABINET

SHEET 3 OF 7

FIBER OPTIC SPLICING DETAILS

STANDARD L2-00

144 SMFO ITS COMMUNICATIONS CABLE  
TO NEXT UPSTREAM ITS DEVICE CABINET

RWIS / WIM CABINET SPLICING DETAILS

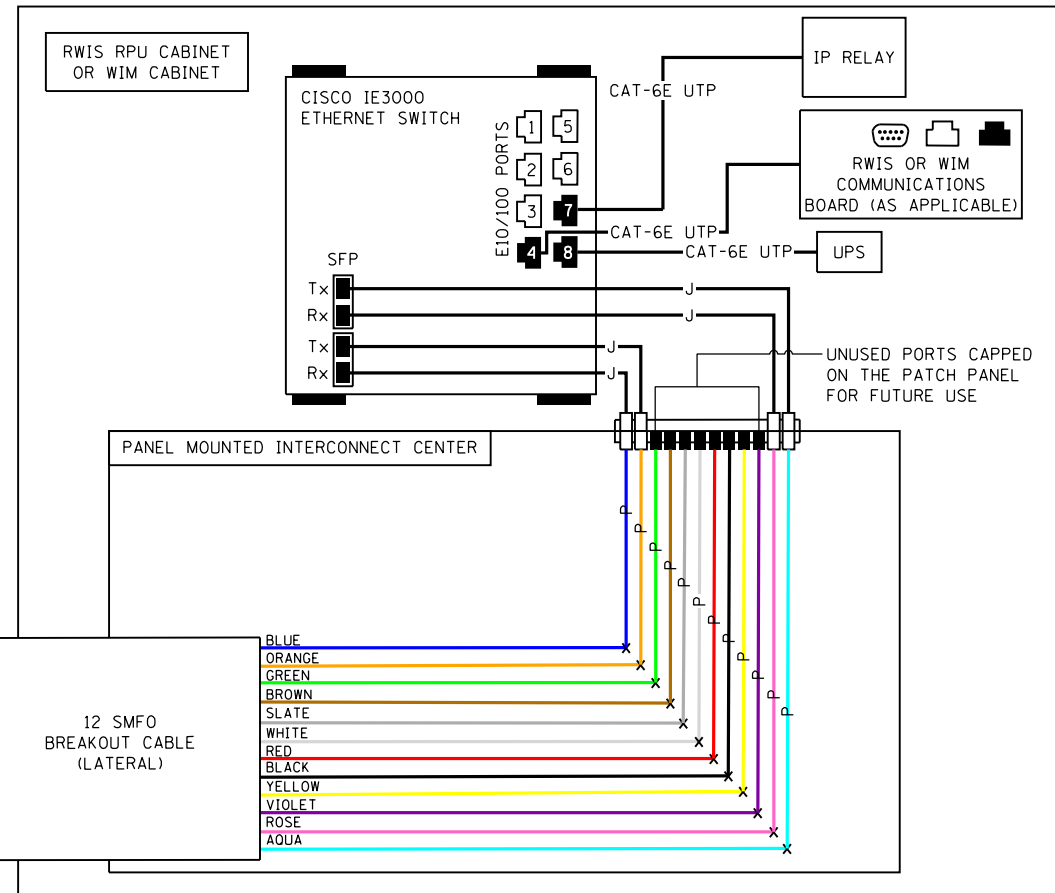
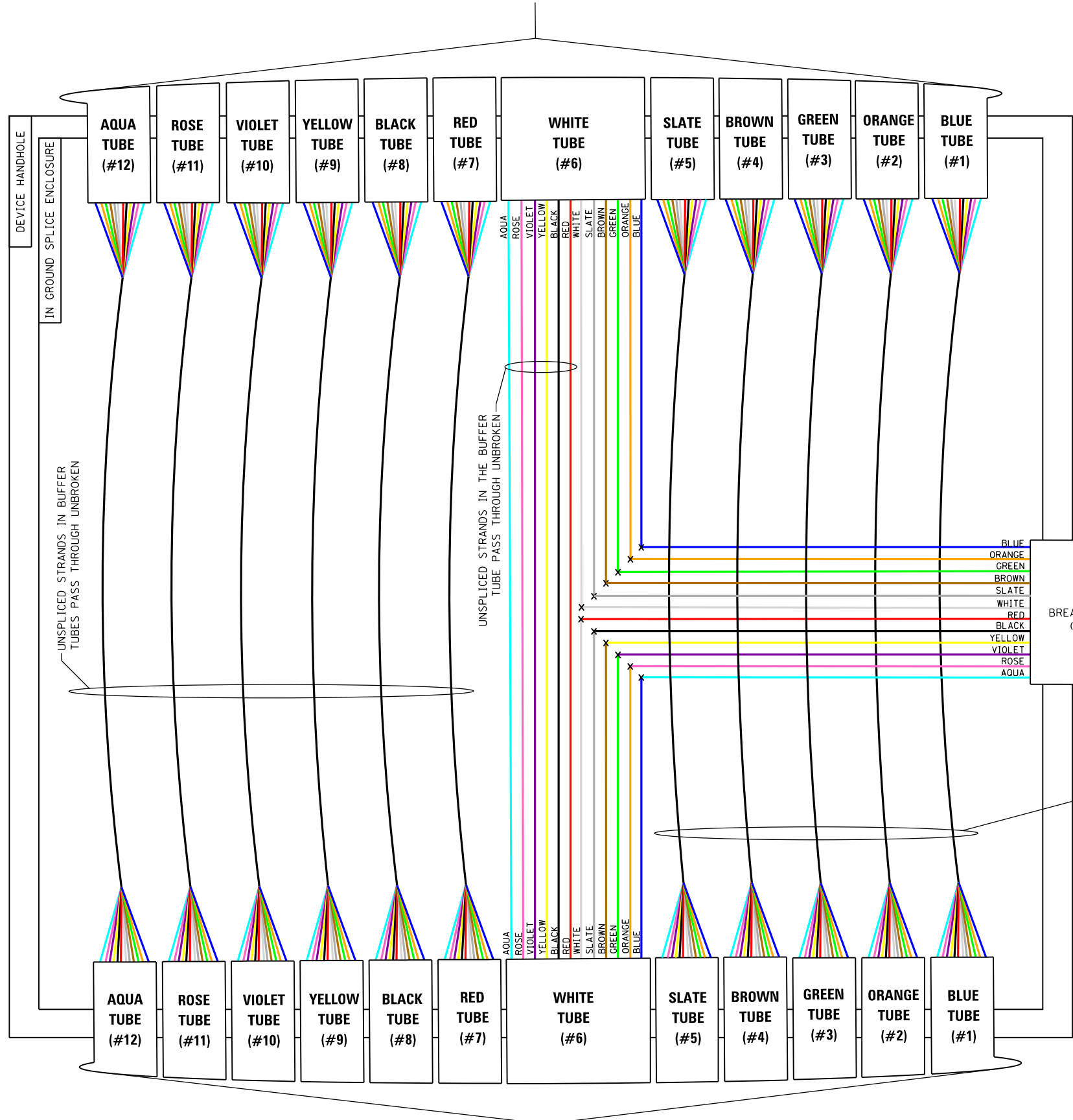

ITS DEVICE GROUP FIBER ASSIGNMENTS (144 SMFO ITS COMMUNICATIONS CABLE)

BUFFER TUBE #1 (BLUE)	- PRIMARY INFRASTRUCTURE SUBGROUP
BUFFER TUBE #2 (ORANGE)	- SECONDARY INFRASTRUCTURE SUBGROUP
BUFFER TUBE #3 (GREEN)	- CCTV & CO-LOCATED ITS DEVICES SUBGROUP (LOCAL FIELD DEVICES)
BUFFER TUBE #4 (BROWN)	- DMS (TYPE 1 & TYPE 2) SUBGROUP (LOCAL FIELD DEVICES)
BUFFER TUBE #5 (SLATE)	- MVDS SUBGROUP (LOCAL FIELD DEVICES)
BUFFER TUBE #6 (WHITE)	- RWIS & WIM SUBGROUP (LOCAL FIELD DEVICES)

**LEGEND**

- FIBER OPTIC JUMPER, SINGLE MODE
- FIBER OPTIC PIGTAIL, SINGLE MODE
- BARE FIBER LEFT COILED IN SPLICE TRAY
- FIBER OPTIC FUSION SPLICE
- FIBER PATCH PANEL, SC CONNECTORS

NOTE:  
SEE SHEET 1 OF 7 FOR NOTES.

*Paul Kovacs*  
APPROVED CHIEF ENGINEER DATE 3-31-2017

144 SMFO ITS COMMUNICATIONS CABLE  
TO NEXT DOWNSTREAM ITS DEVICE CABINET



144 SMFO ITS COMMUNICATIONS  
CABLE TO NEXT UPSTREAM DEVICE

IPDC/PLAZA/OASIS/MAINTENANCE BUILDING  
NETWORK SWITCH CONNECTION DETAILS - ITS

ITS DEVICE GROUP FIBER ASSIGNMENTS (144 SMFO ITS COMMUNICATIONS CABLE)

BUFFER TUBE #1 (BLUE)	- PRIMARY INFRASTRUCTURE SUBGROUP
BUFFER TUBE #2 (ORANGE)	- SECONDARY INFRASTRUCTURE SUBGROUP
BUFFER TUBE #3 (GREEN)	- CCTV & CO-LOCATED ITS DEVICES SUBGROUP (LOCAL FIELD DEVICES)
BUFFER TUBE #4 (BROWN)	- DMS (TYPE 1 & TYPE 2) SUBGROUP (LOCAL FIELD DEVICES)
BUFFER TUBE #5 (SLATE)	- MVDS SUBGROUP (LOCAL FIELD DEVICES)
BUFFER TUBE #6 (WHITE)	- RWIS & WIM SUBGROUP (LOCAL FIELD DEVICES)

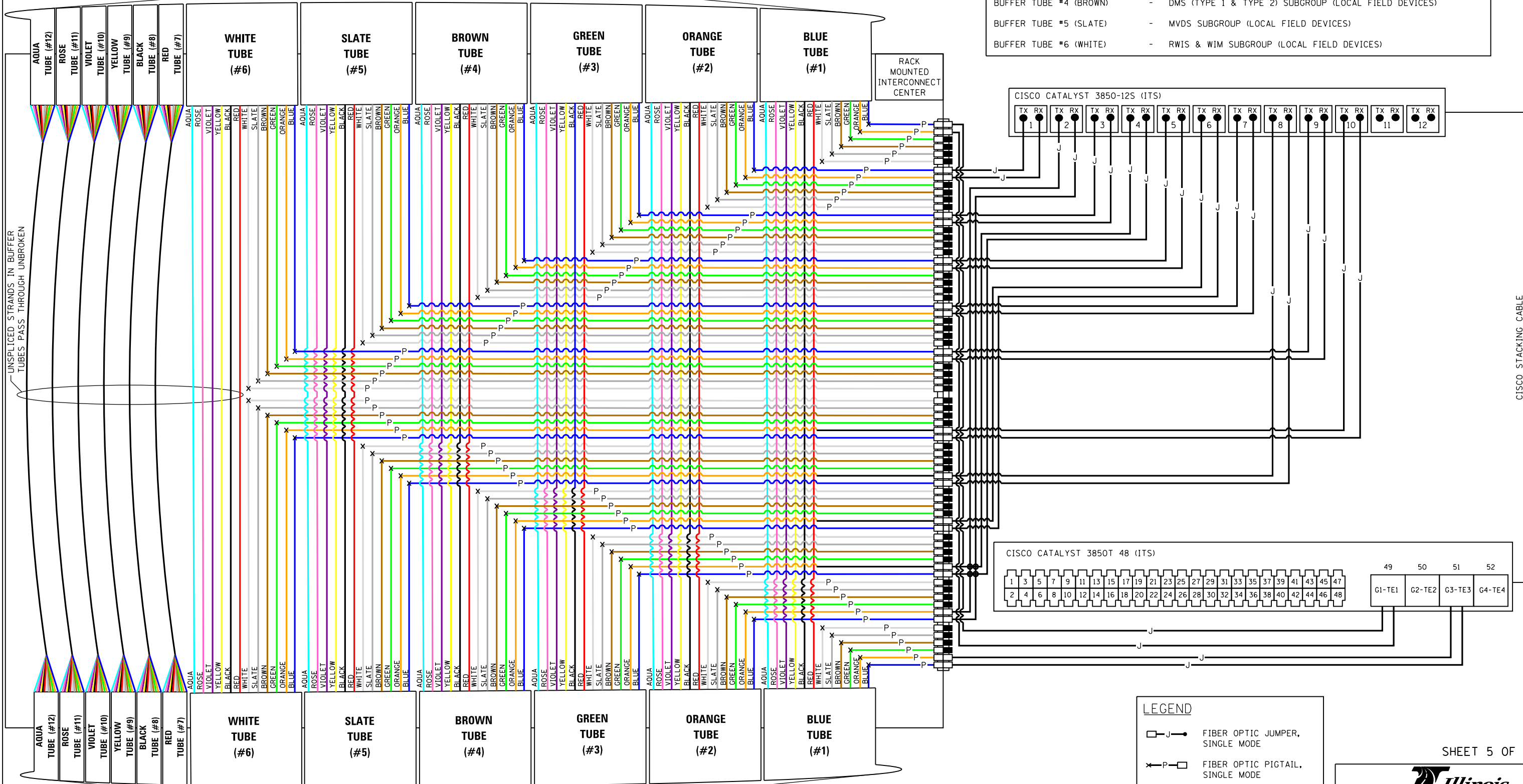

UNSPliced STRANDS IN BUFFER  
TUBES PASS THROUGH UNBROKEN

CISCO STACKING CABLE  
(CAB-STACK-XXCM)

144 SMFO ITS COMMUNICATIONS  
CABLE TO NEXT DOWNSTREAM DEVICE

NOTE:  
SEE SHEET 1 OF 7 FOR NOTES.

**LEGEND**

- FIBER OPTIC JUMPER, SINGLE MODE
- FIBER OPTIC PIGTAIL, SINGLE MODE
- BARE FIBER LEFT COILED IN SPLICE TRAY
- FIBER OPTIC FUSION SPLICE
- FIBER PATCH PANEL, SC CONNECTORS

APPROVED *Paul Kovacs* CHIEF ENGINEER DATE 3-31-2017

SHEET 5 OF 7

FIBER OPTIC  
SPLICING DETAILS

STANDARD L2-00

144 SMFO TOLLWAY BACKBONE  
CABLE TO NEXT TOLL PLAZA

AET GROUP FIBER ASSIGNMENTS (144 SMFO TOLLWAY BACKBONE CABLE)  
BUFFER TUBE #1 (BLUE) - PRIMARY INFRASTRUCTURE SUBGROUP

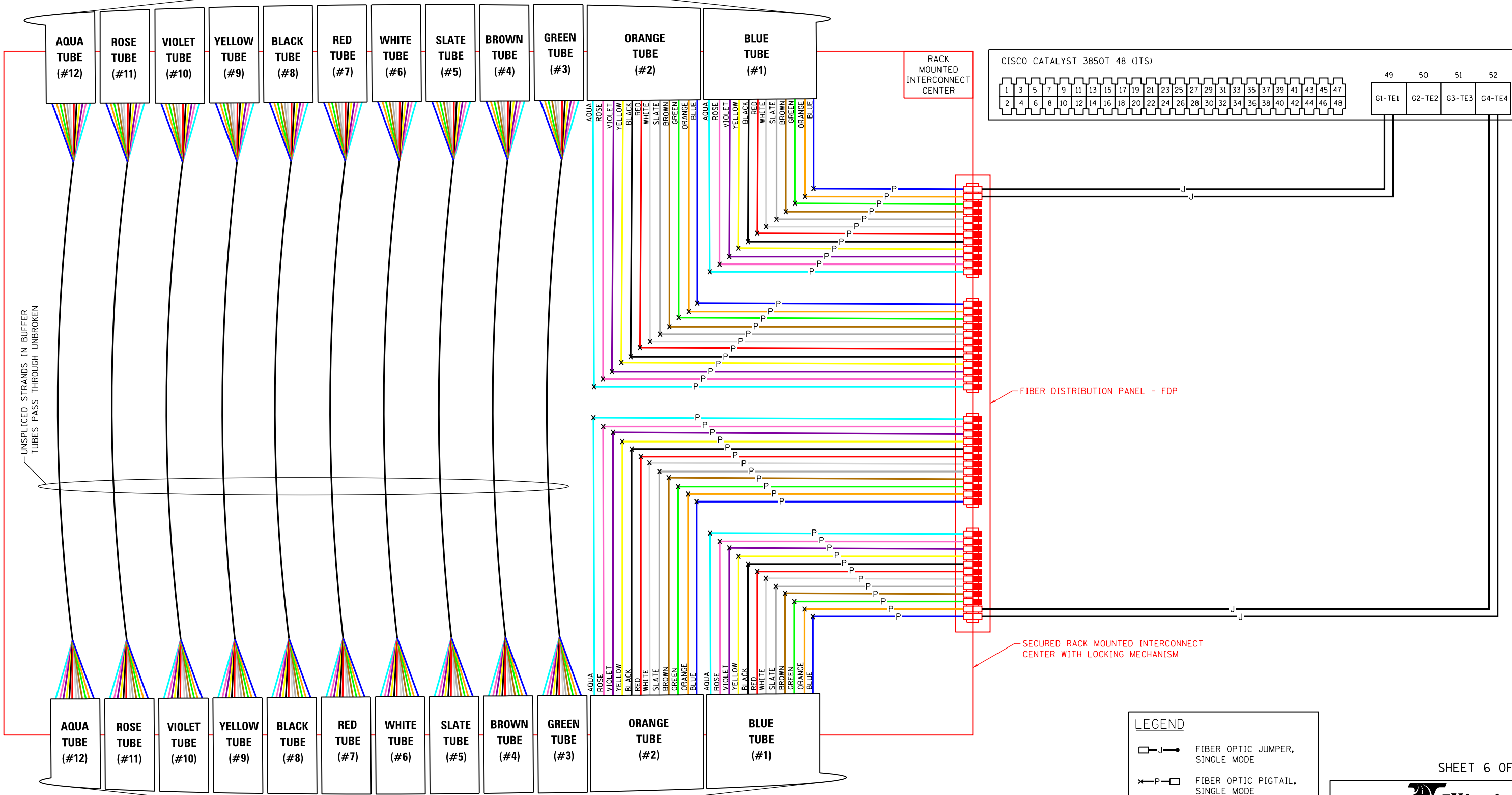

UNSPliced STRANDS IN BUFFER  
TUBES PASS THROUGH UNBROKEN

RACK MOUNTED  
INTERCONNECT  
CENTER

CISCO CATALYST 3850T 48 (ITS)

1	3	5	7	9	11	13	15	17	19	21	23	25	27	29	31	33	35	37	39	41	43	45	47	49	50	51	52
2	4	6	8	10	12	14	16	18	20	22	24	26	28	30	32	34	36	38	40	42	44	46	48	G1-TE1	G2-TE2	G3-TE3	G4-TE4

FIBER DISTRIBUTION PANEL - FDP

SECURED RACK MOUNTED INTERCONNECT  
CENTER WITH LOCKING MECHANISM

**LEGEND**

- J — FIBER OPTIC JUMPER, SINGLE MODE
- P — FIBER OPTIC PIGTAIL, SINGLE MODE
- BARE FIBER LEFT COILED IN SPLICE TRAY
- × FIBER OPTIC FUSION SPLICE
- [Grid Icon] FIBER PATCH PANEL, SC CONNECTORS

NOTE:  
SEE SHEET 1 OF 7 FOR NOTES.

*Paul Kovacs*  
APPROVED CHIEF ENGINEER DATE 3-31-2017

144 SMFO TOLLWAY BACKBONE  
CABLE TO NEXT TOLL PLAZA

SHEET 6 OF 7

FIBER OPTIC  
SPLICING DETAILS

STANDARD L2-00

PROPOSED NETWORK SWITCH PORT ASSIGNMENT SCHEMATIC

CISCO WS-3850-48T ETHERNET SWITCH  
10/100/1000 ETHERNET AND 10G SFP PORT ARRANGEMENT

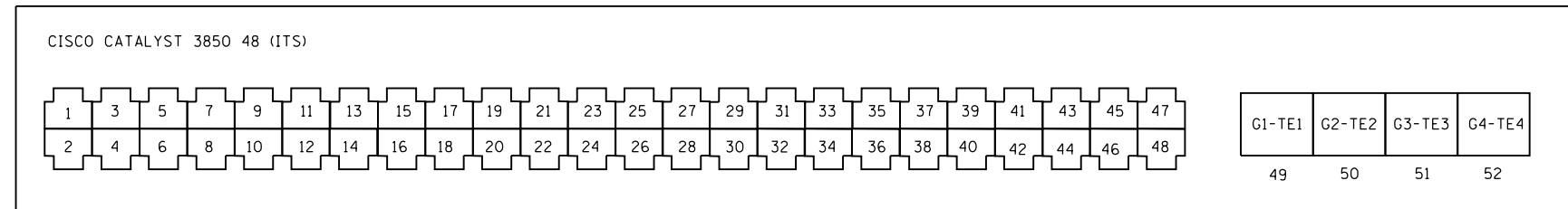

- |                               |                               |                               |                               |
|-------------------------------|-------------------------------|-------------------------------|-------------------------------|
| 1. LOCALLY CONNECTED DEVICES  | 13. LOCALLY CONNECTED DEVICES | 25. LOCALLY CONNECTED DEVICES | 37. LOCALLY CONNECTED DEVICES |
| 2. LOCALLY CONNECTED DEVICES  | 14. LOCALLY CONNECTED DEVICES | 26. LOCALLY CONNECTED DEVICES | 38. LOCALLY CONNECTED DEVICES |
| 3. LOCALLY CONNECTED DEVICES  | 15. LOCALLY CONNECTED DEVICES | 27. LOCALLY CONNECTED DEVICES | 39. LOCALLY CONNECTED DEVICES |
| 4. LOCALLY CONNECTED DEVICES  | 16. LOCALLY CONNECTED DEVICES | 28. LOCALLY CONNECTED DEVICES | 40. LOCALLY CONNECTED DEVICES |
| 5. LOCALLY CONNECTED DEVICES  | 17. LOCALLY CONNECTED DEVICES | 29. LOCALLY CONNECTED DEVICES | 41. LOCALLY CONNECTED DEVICES |
| 6. LOCALLY CONNECTED DEVICES  | 18. LOCALLY CONNECTED DEVICES | 30. LOCALLY CONNECTED DEVICES | 42. LOCALLY CONNECTED DEVICES |
| 7. LOCALLY CONNECTED DEVICES  | 19. LOCALLY CONNECTED DEVICES | 31. LOCALLY CONNECTED DEVICES | 43. LOCALLY CONNECTED DEVICES |
| 8. LOCALLY CONNECTED DEVICES  | 20. LOCALLY CONNECTED DEVICES | 32. LOCALLY CONNECTED DEVICES | 44. LOCALLY CONNECTED DEVICES |
| 9. LOCALLY CONNECTED DEVICES  | 21. LOCALLY CONNECTED DEVICES | 33. LOCALLY CONNECTED DEVICES | 45. LOCALLY CONNECTED DEVICES |
| 10. LOCALLY CONNECTED DEVICES | 22. LOCALLY CONNECTED DEVICES | 34. LOCALLY CONNECTED DEVICES | 46. LOCALLY CONNECTED DEVICES |
| 11. LOCALLY CONNECTED DEVICES | 23. LOCALLY CONNECTED DEVICES | 35. LOCALLY CONNECTED DEVICES | 47. LOCALLY CONNECTED DEVICES |
| 12. LOCALLY CONNECTED DEVICES | 24. LOCALLY CONNECTED DEVICES | 36. LOCALLY CONNECTED DEVICES | 48. LOCALLY CONNECTED DEVICES |

- TE1 - (AET/ITS) PRIMARY LAYER 3 UPLINK  
TE3 - (AET/ITS) PRIMARY LAYER 3 DOWNLINK
- OR
- TE2 - (AE/ITS) PRIMARY LAYER 3 UPLINK  
TE4 - (AE/ITS) PRIMARY LAYER 3 DOWNLINK

CISCO IE-3000-8TC-E ETHERNET SWITCH  
10/100/1000 SFP PORT ARRANGEMENT

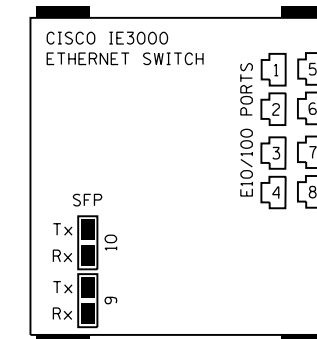

- LOCAL USE
- CCTV CAT-6 CONNECTION
- CCTV CAT-6 CONNECTION
- RWIS COMMUNICATION BOARD / WIM CONTROLLER
- DMS CONTROLLER
- MVDS
- IP RELAY CAT-6 CONNECTION
- UPS (POWER)
- FIELD SWITCH UPLINK
- FIELD SWITCH DOWNLINK

CISCO WS-3850-12S-E ETHERNET SWITCH  
10/100/1000 SFP PORT ARRANGEMENT

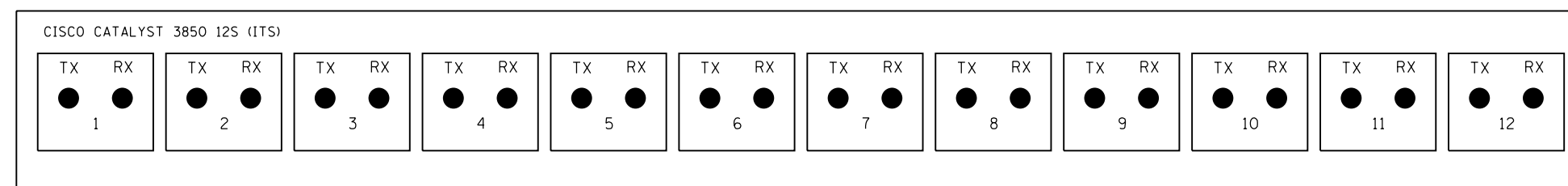

- |  |  |
|--|--|
| 1. (AET/ITS) SECONDARY LAYER 3 UPLINK                  | 7. (ITS) MVDS SUBGROUP - UPLINK        |
| 2. (AET/ITS) SECONDARY LAYER 3 DOWNLINK                | 8. (ITS) MVDS SUBGROUP - DOWNLINK      |
| 3. (ITS) CCTV & CO-LOCATED DEVICES SUBGROUP - UPLINK   | 9. (ITS) CONNECTED VEHICLE - UPLINK    |
| 4. (ITS) CCTV & CO-LOCATED DEVICES SUBGROUP - DOWNLINK | 10. (ITS) CONNECTED VEHICLE - DOWNLINK |
| 5. (ITS) DMS SUBGROUP - UPLINK                         | 11. NOT USED                           |
| 6. (ITS) DMS SUBGROUP - DOWNLINK                       | 12. NOT USED                           |



FIBER OPTIC  
SPLICING DETAILS

STANDARD L2-00

NOTES:

- SEE SHEET 1 OF 7 FOR NOTES.
- ALL NETWORK SWITCH CONNECTIONS SHOWN ON THIS SHEET SHALL BE PERFORMED BY THE TOLLWAY FIBER MAINTENANCE TEAM, IN COORDINATION WITH THE ENGINEER.

*Paul Kovacs*  
APPROVED ..... CHIEF ENGINEER ..... DATE 3-31-2017