

Illinois Tollway Standard Drawing Revisions
--

Section D	Roadway Appurtenances
------------------	------------------------------

Standard	Modification Summary	Effective: 03-31-2017
D1	Right of Way Fence	
Sheet 1	Revised Note 5 to remove reference to incidental work.	
Sheet 3	Revised Note 2 for Installation Around Headwalls to remove reference to incidental work.	
	Revised Note for Detail A to remove reference to incidental work.	
D4	Roadway Delineators and Reflectors	
Sheet 1	Changes to reflector spacing along ramp curves for guardrail, barrier wall and crash-worthy noise abatement walls.	
D6	Pavement Marking and Shoulder Rumble Strip Details	
Sheet 1	Revised General Note 1 to clarify lengths of auxiliary, acceleration and deceleration lanes.	
	Revised pavement marking lane size on exit lane ramp with lane drop detail.	
	Added callout for skip dash pavement marking line to two lane parallel ramp exit detail	
	Clarified dimension to exit sign on single lane ramp with lane drop detail.	
	Clarified callout on use of RPMs and 6" dotted line in curves	
	Clarified callout on ending rumble strips	
Sheet 2	Added label for 6" Dotted Line to two lane entrance ramp detail	
	Revised position of note for clarity.	
	Clarified callout on ending rumble strips	
Sheet 3	6" skip dash line moved to right side of centerline on Ramp - 2 Lanes detail.	

 New Sheet	 Retired Standard	
---	---	--

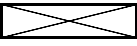
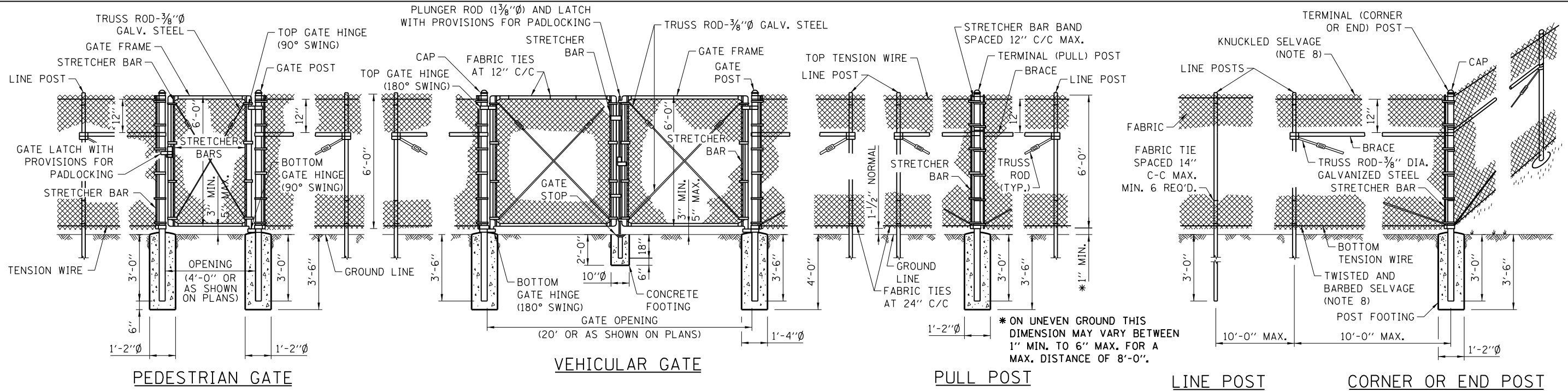

RIGHT OF WAY FENCE, TYPE 1, 6'

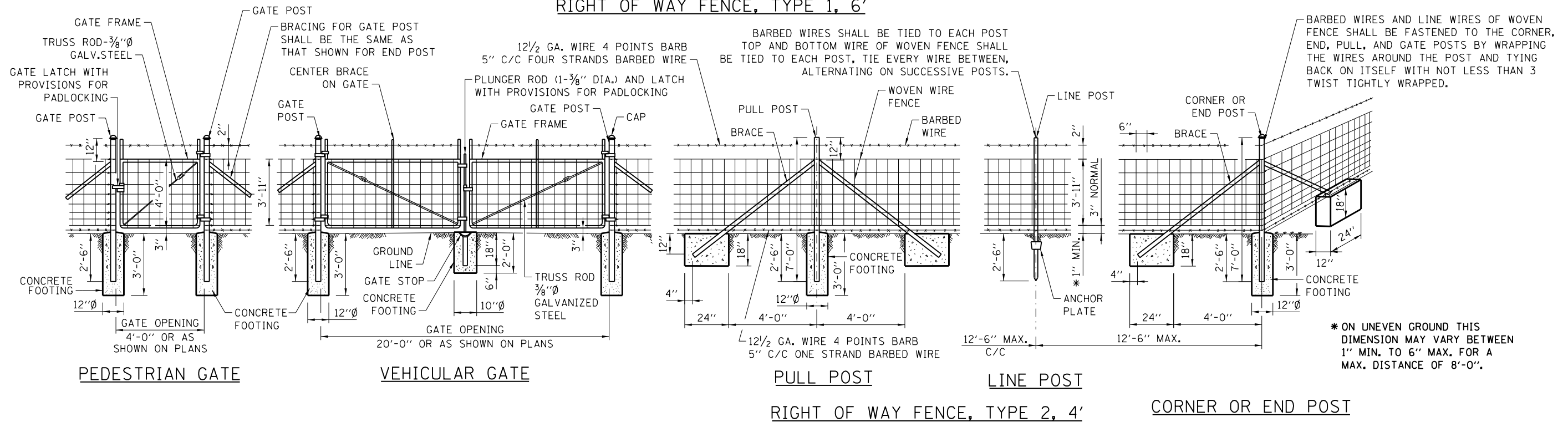

GENERAL NOTES

- ON STRAIGHT RUNS OF FENCE, PULL POSTS SHALL BE USED AT 500' CENTERS FOR TYPE 1 AND 330' CENTERS FOR TYPE 2.
- WHERE R.O.W. FENCE FOLLOWS R.O.W. LINE IT SHALL BE INSTALLED PARALLEL TO AND 6" INSIDE THE R.O.W. LINE ON ILLINOIS TOLLWAY PROPERTY.
- LINE POSTS AND BRACES SHALL BE ON ILLINOIS TOLLWAY SIDE OF FENCE FABRIC.
- WHEN THE TENSION OF THE FENCE TENDS TO PULL THE POSTS FROM THE GROUND, THE LINE POSTS SHALL BE ANCHORED WITH ANCHORAGE SPECIFIED FOR CORNER POSTS.
- WHEN THE FENCE LINE HAS A CHANGE IN DIRECTION OF 10° OR MORE, A CORNER POST SHALL BE PLACED AT THE POINT OF CHANGE. WHERE THE ANGLE OF CHANGE IS LESS THAN 10° A PULL POST SHALL BE USED.
- WHERE GRADE LINE HAS A CHANGE IN SLOPE OF 10° OR MORE, A CORNER POST WITH BRACING AS REQUIRED SHALL BE PLACED. WHERE ANGLE IS LESS THAN 10° LINE POST MAY BE USED.
- WHERE RIGHT-OF-WAY FENCE, TYPE 1 IS USED, THE FABRIC SHALL BE KNUCKLED SELVAGE ON TOP AND TWISTED AND BARBED SELVAGE ON BOTTOM.
- PLACEMENT OF BRACED END POSTS OR CORNER POSTS WITHIN THE CLEAR ZONE SHALL BE AVOIDED.



DATE	REVISIONS
7-01-2009	R.O.W. FENCE TYPES 1 AND 2 FENCE DETAILS
11-01-2012	REVISED NOTES
3-31-2014	REVISED ROLLED FORM SECTIONS
3-11-2015	REVISED NOTES
3-31-2017	REVISED NOTES

RIGHT OF WAY FENCE

STANDARD D1-05

APPROVED *Paul Kovacs* CHIEF ENGINEER DATE 7-1-2009

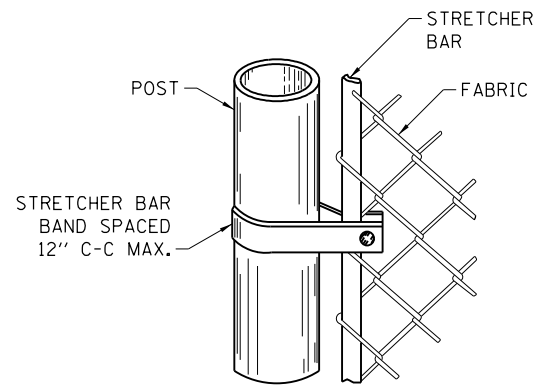

STRETCHER BARS SHALL BE GALVANIZED FLAT STEEL BAR NOT LESS THAN $\frac{1}{4}$ " x $\frac{3}{4}$ " AND THE STRETCHER BAR BANDS SHALL BE GALVANIZED FLAT STEEL BAR NOT LESS THAN $\frac{1}{8}$ " x 1" WITH A $\frac{3}{8}$ " GALVANIZED CARRIAGE BOLT.

METHOD OF FASTENING STRETCHER BAR TO POST

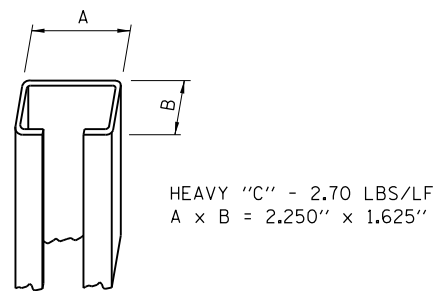
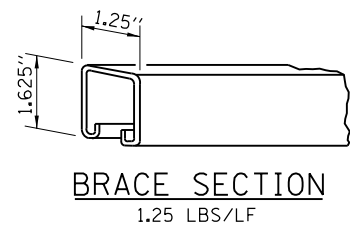

LINE POST 'C' SECTION

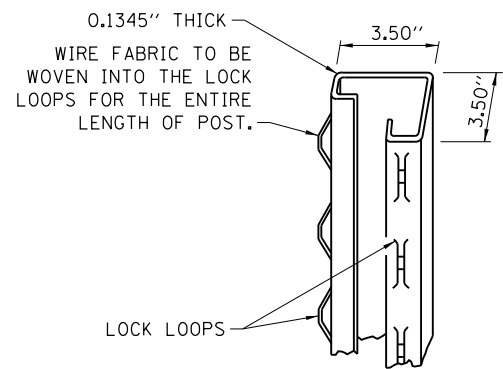

TERMINAL POST SECTION
5.10 LBS/LF

DETAILS OF ROLL FORMED SECTIONS

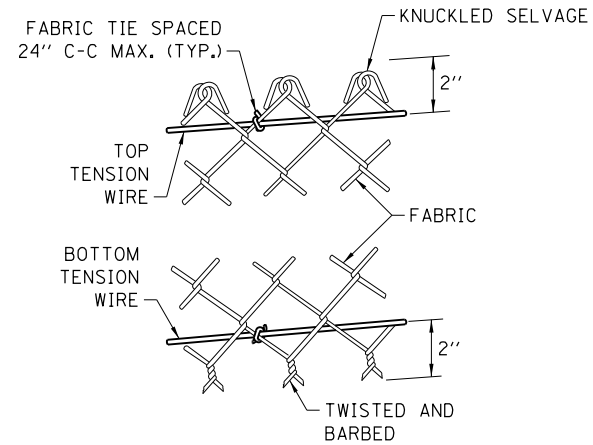

METHOD OF TYING FABRIC TO TENSION WIRES

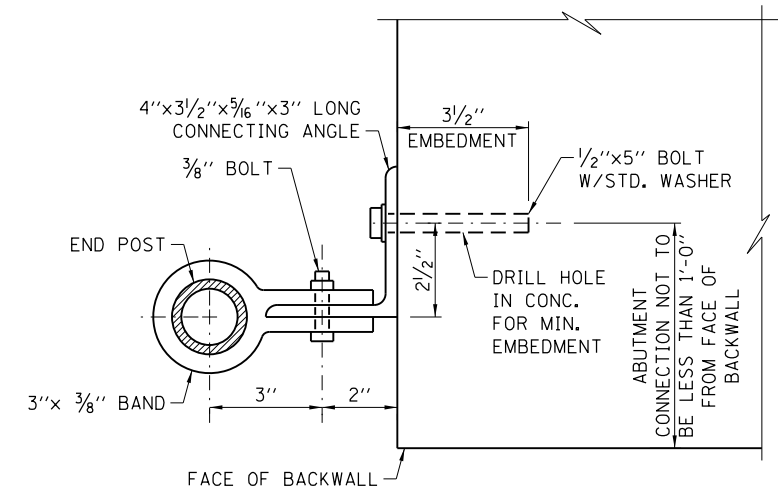

ABUTMENT CONNECTION DETAIL

NOTES FOR ABUTMENT CONNECTION:

1. WHEN ROLL FORMED SECTION IS USED IN LIEU OF PIPE AS END POST, THE POST SHALL BE BOLTED DIRECTLY TO THE ABUTMENT WALL WITH $2\frac{1}{2}$ " x 5" BOLTS WITH STANDARD WASHERS MEETING THE APPROVAL OF THE ENGINEER.

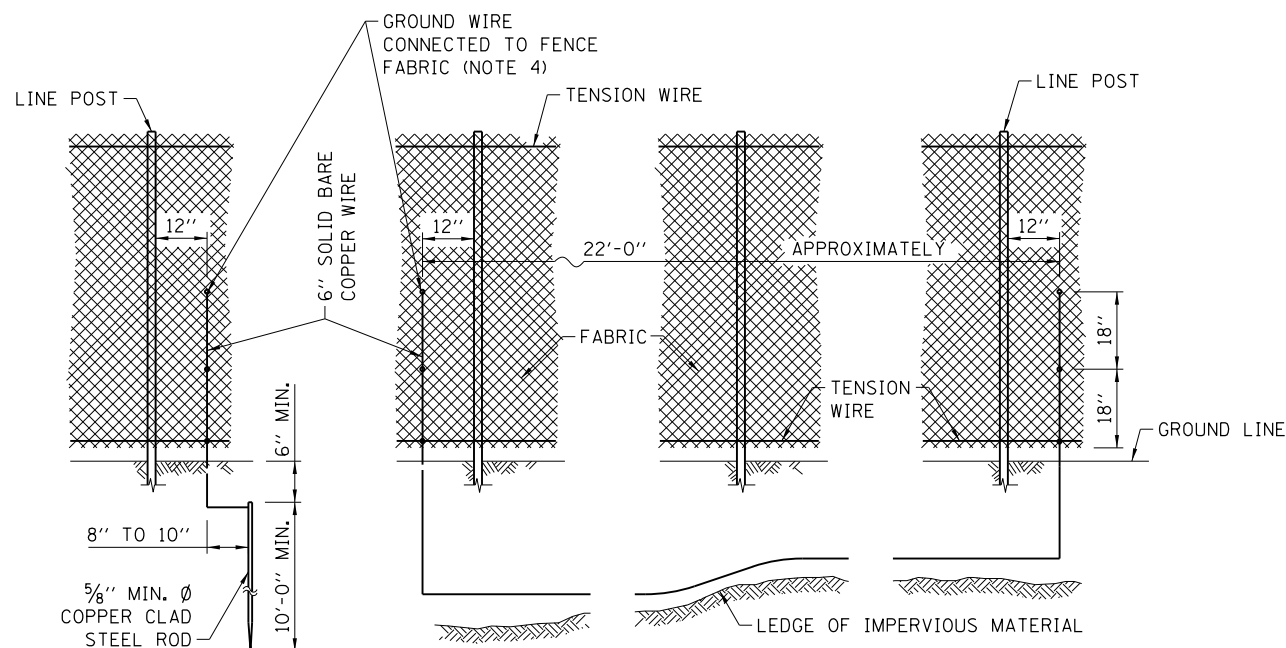

STANDARD GROUND

COUNTERPOISE GROUND (ALTERNATE)

NOTES FOR STANDARD AND COUNTERPOISE GROUND:

1. THE INTERVALS FOR GROUNDING CONTINUOUS FENCING SHALL NOT EXCEED 500 FEET IN URBAN AREAS AND 1000 FEET IN RURAL AREAS. FENCE ADJACENT TO A GATE SHALL BE GROUNDED A MAXIMUM DISTANCE 100 FEET EACH SIDE OF THE GATE.
2. FENCE CROSSING UNDER A POWER LINE SHALL BE GROUNDED, ONCE DIRECTLY UNDER THE CROSSING AND ONE ON EACH SIDE AT 25 TO 50 FEET AWAY. FENCE LOCATED DIRECTLY UNDER A TELEPHONE WIRE OR CABLE CROSSING SHALL HAVE A SINGLE GROUND.
3. COUNTERPOISE GROUNDS SHALL BE USED AT LOCATIONS WHERE GROUND RODS CAN NOT BE DRIVEN DUE TO IMPERVIOUS EARTH MATERIALS.
4. THE GROUND WIRES SHALL BE CONNECTED TO FENCE FABRIC AND GROUND ROD BY STAINLESS STEEL BOLTS AND WASHERS. THE LOWER CONNECTION OF THE GROUND WIRE SHALL BE MADE TO THE BOTTOM TENSION WIRE.

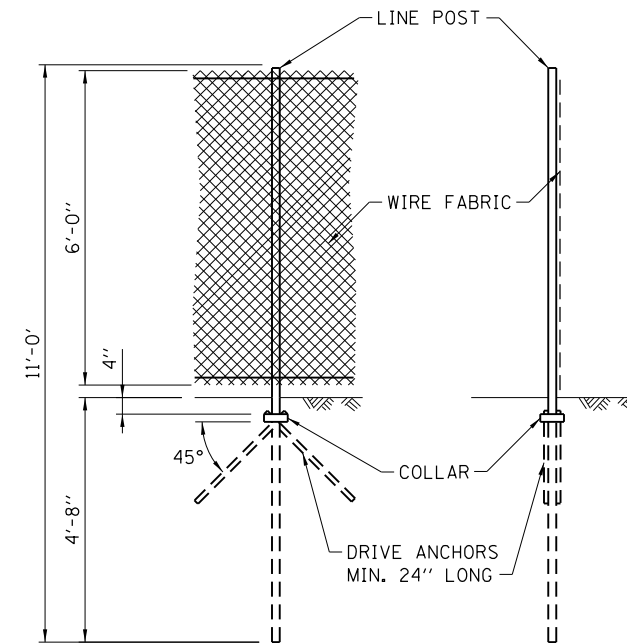

ALTERNATE DRIVEN LINE POST ANCHORAGE WITH OR WITHOUT DRIVE ANCHORS

NOTE FOR FENCE POST:

ALTERNATE DRIVEN LINE POST ANCHORAGE IS OPTIONAL. DRIVEN LINE POST ANCHORAGE WITHOUT DRIVE ANCHORS MAY BE USED IN AVERAGE TO GOOD SOIL CONDITIONS. WHEN SOIL IS WEAKER ($Q_u < 1.25$ TONS/SQ. FT.) AND STABILITY OF THE POST IS QUESTIONABLE, DRIVE ANCHORS SHALL BE USED. TYPES, SHAPES, DIMENSIONS AND COATING REQUIREMENTS OF DRIVE ANCHORS (ANCHOR BLADES AND COLLARS) FOR DIFFERENT TYPE OF POSTS SHALL BE AS RECOMMENDED BY THE MANUFACTURER.

ELECTRICAL GROUNDING DETAILS

APPROVED *Paul Kovacs* CHIEF ENGINEER DATE 7-1-2009



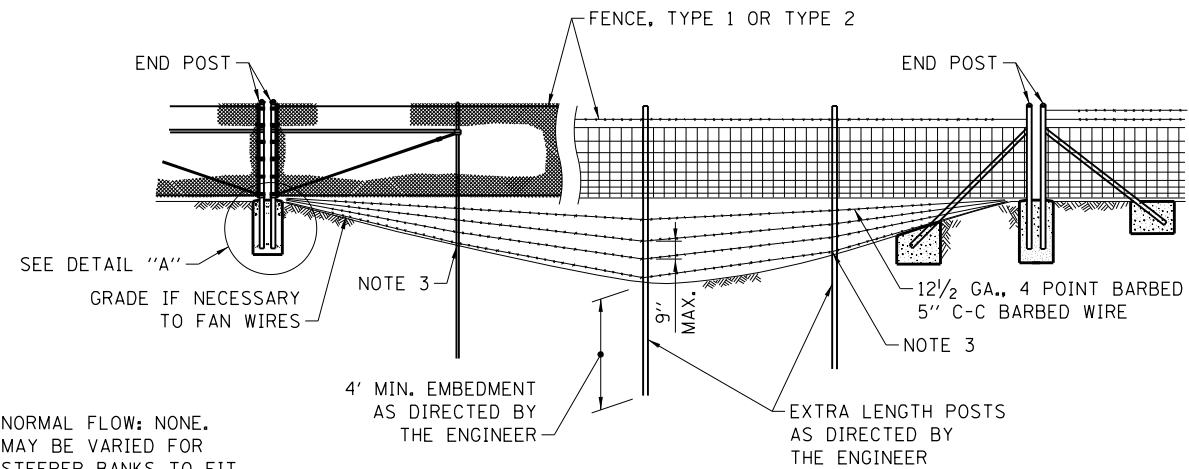

NORMAL FLOW: NONE.
MAY BE VARIED FOR
STEEPER BANKS TO FIT
VARIOUS CHANNEL SECTIONS.

STREAM CROSSING, TYPE 1

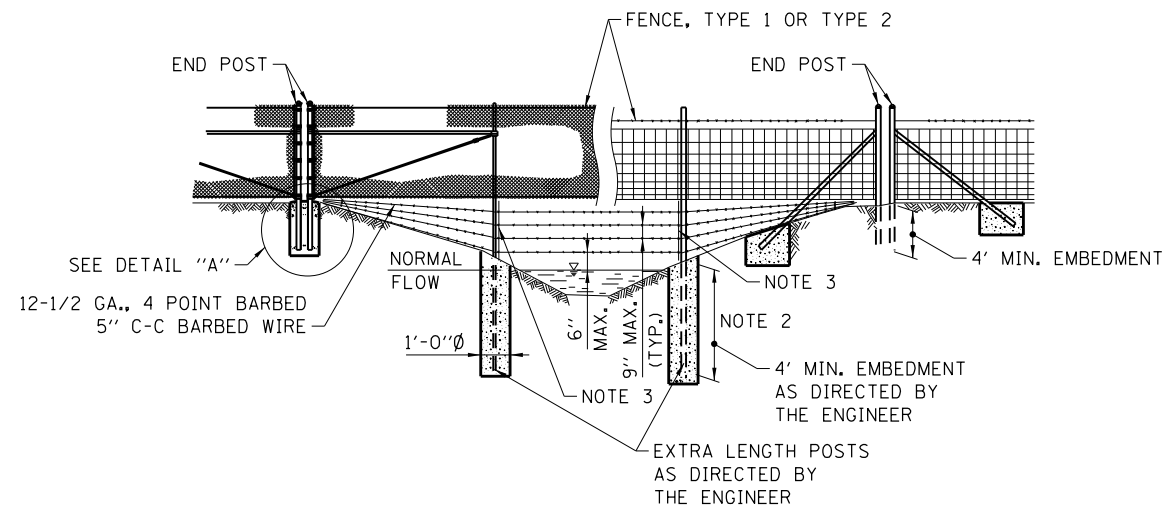

STREAM CROSSING, TYPE 2

NOTES FOR STREAM CROSSING TYPE 1 AND TYPE 2:

1. THESE INSTALLATION CONDITIONS ARE TYPICAL AND ARE NOT TO BE CONSTRUED AS REPRESENTATIVE OF ALL CONDITIONS WHICH WILL BE ENCOUNTERED. CONSTRUCTION WILL BE VARIED AS REQUIRED OR DIRECTED TO MEET FIELD CONDITIONS.
2. FOR STREAM CROSSING OF THE TYPE REQUIRED THE BOTTOM BARBED WIRE SHALL BE ANCHORED TO CONCRETE FOOTING OR TO HOLES DRILLED IN POSTS, AND INTERMEDIATE WIRES SHALL BE TIED TO THE BOTTOM WIRE AND TO POSTS IN AN EVENLY SPACED FASHION TO PREVENT SLIPPAGE.
3. CONCRETE AND FITTINGS FOR ALL TYPES OF FENCE SHALL BE AS DETAILED FOR SIMILAR CONDITIONS PER STANDARD DRAWING.

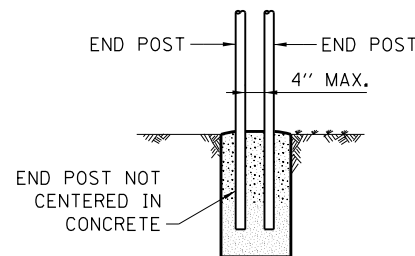

THE FENCE FABRIC SHALL BE REPLACED BY BARBED WIRE STRANDS AT 12\"/>

DETAIL A

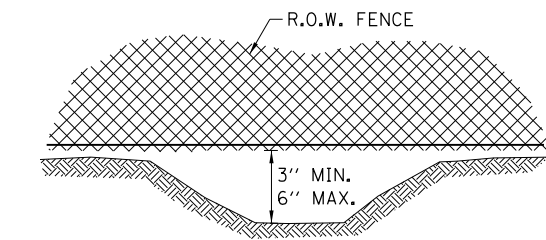

FENCE INSTALLATION OVER DITCH

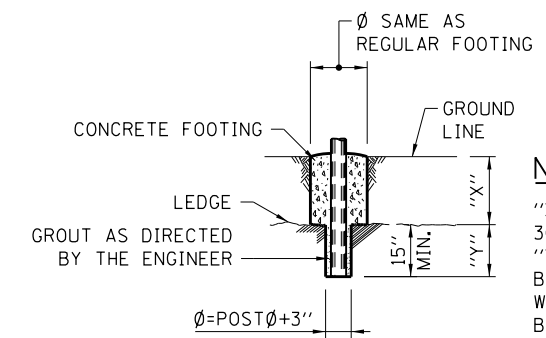

NOTE:
"X" + "Y" SHALL NOT EXCEED 30" WHEN "X" IS 0" TO 15" "Y" = 15", AND THE POST SHALL BE SHORTENED AS REQUIRED. WHEN "X" EXCEEDS 15" "Y" SHALL BE DECREASED ACCORDINGLY.

FOOTING FOR POST WHEN ROCK LEDGE IS ENCOUNTERED

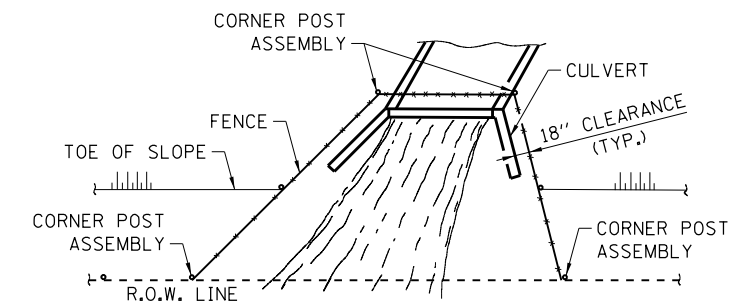

PLAN AT HEADWALL

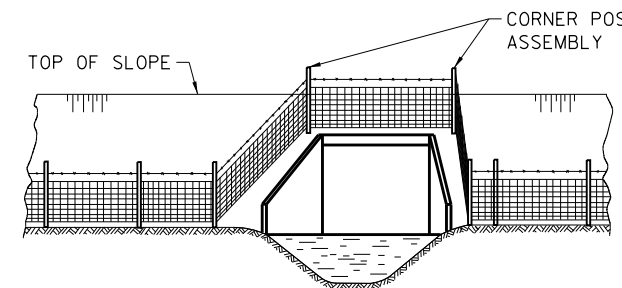

ELEVATION

NOTES FOR INSTALLATION AROUND HEADWALL:

1. THIS TYPE OF INSTALLATION IS TO BE USED ONLY WHEN SPECIFICALLY CALLED FOR IN THE CONTRACT PLANS.
2. WHEN THE WIDTH OF THE CULVERT MAKES NECESSARY TO ANCHOR A POST TO THE TOP OF THE CULVERT, A CAST IRON SHOE OR OTHER DEVICE APPROVED BY THE ENGINEER SHALL BE USED.

INSTALLATION AROUND HEADWALL



SURVEY AND ROADWAY ITEMS

EXISTING	PROPOSED	
		CONSTRUCTION JOINT W/DOWEL BARS
		BENCHMARK
		CANTILEVER SIGN STRUCTURE
		BUTTERFLY SIGN STRUCTURE
		DOUBLE COLUMN GROUND MOUNTED SIGN
		SINGLE COLUMN GROUND MOUNTED SIGN
		SPAN TYPE SIGN STRUCTURE
		TRIPLE COLUMN GROUND MOUNTED SIGN
		RUMBLE STRIP

EROSION & SEDIMENT CONTROL, LANDSCAPING ITEMS

EXISTING	PROPOSED		EXISTING	PROPOSED	
		CLEARING & GRADING LIMITS (LIMITS OF CONSTRUCTION)			EROSION CONTROL BLANKET
		DIVERSION DIKE			OVER SEEDING CLASS B1
		DRAINAGE DIVIDE			OVER SEEDING CLASS B2
		DRAINAGE PATH			SEEDING CLASS A1
		SEDIMENT BASIN AGGREGATE BERM			SEEDING CLASS A2
		CULVERT INLET PROTECTION-STONE			SEEDING CLASS A3
		CULVERT INLET PROTECTION-FENCE			SEEDING CLASS A4
		DEWATERING BASIN			SEEDING CLASS A5
		FILTER FABRIC INLET PROTECTION, BASKET TYPE			SEEDING CLASS A6
		FILTER FABRIC INLET PROTECTION, COVER TYPE			SEEDING CLASS D1
		FLOTATION BOOM			SODDING (SALT TOLERANT)
		INITIAL CONSTRUCTION ITEM			TEMPORARY GROUND COVER
		RECTANGULAR INLET PROTECTION			TURF REINFORCEMENT MAT
		TEMPORARY ROCK CHECK DAM			
		TEMPORARY DITCH CHECK			
		SEDIMENT BASIN			
		SILT FENCE			
		SUPER SILT FENCE			
		STABILIZED CONSTRUCTION ENTRANCE			
		STONE OUTLET STRUCTURE			
		SEDIMENT TRAP			
		STREAM DIVERSION			
		TEMPORARY PIPE SLOPE DRAIN			
		TEMPORARY RIPRAP			
		TEMPORARY SWALE			
		TREES AND STUMP			
		TREE PROTECTION			
		TEMPORARY STREAM CROSSING			

DRAINAGE AND UTILITY ITEMS; ROADWAY LIGHTING AND SIGNS

EXISTING	PROPOSED	
		BOX CULVERT WITH HEADWALL
		CABLE IN DUCT W/O GROUND
		LOW POINT
		OVERHEAD ELECTRICAL
		OVERHEAD TELEPHONE
		PIPE CULVERT
		LAKE OR POND
		QUARRY
		STREAM
		SWAMP
		CABLE OR CONDUIT TAG
		ELECTRICAL MANHOLE
		LIGHT-DUTY BOX
		ROADWAY LUMINAIRE
		STEEL TOWER
		TELEPHONE MANHOLE
		UNDERPASS LUMINAIRE
		WATER POINT
		WATERMAIN VALVE VAULT
		WATER WELL
		WOOD POLE

APPROVED *Paul Kovacs* CHIEF ENGINEER DATE 7-1-2009



DATE	REVISIONS
7-01-2009	REVISED SYMBOL & PATTERNS
11-01-2012	ADDED NEW SYMBOLS
3-11-2015	ADDED NEW SYMBOL
3-31-2016	UPDATED DITCH CHECK SYMBOL

SYMBOLS AND PATTERNS

STANDARD D2-04

ELECTRICAL AND MECHANICAL ITEMS

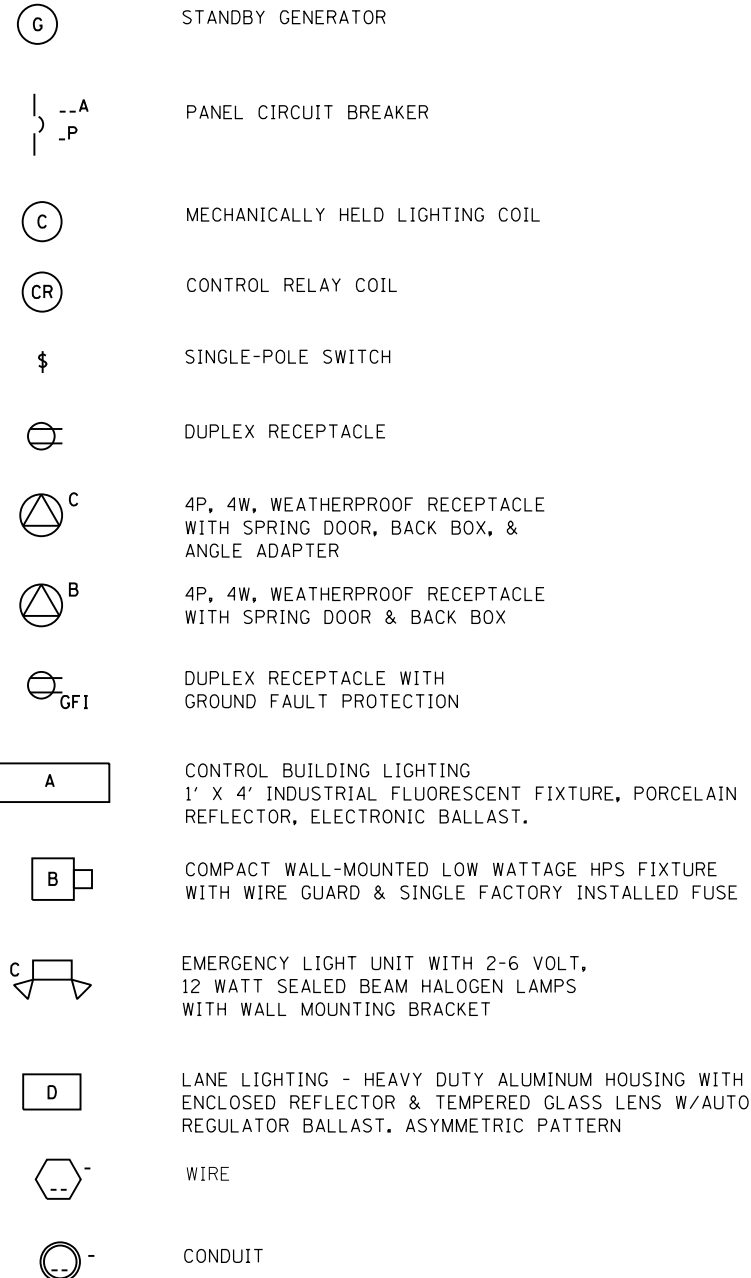
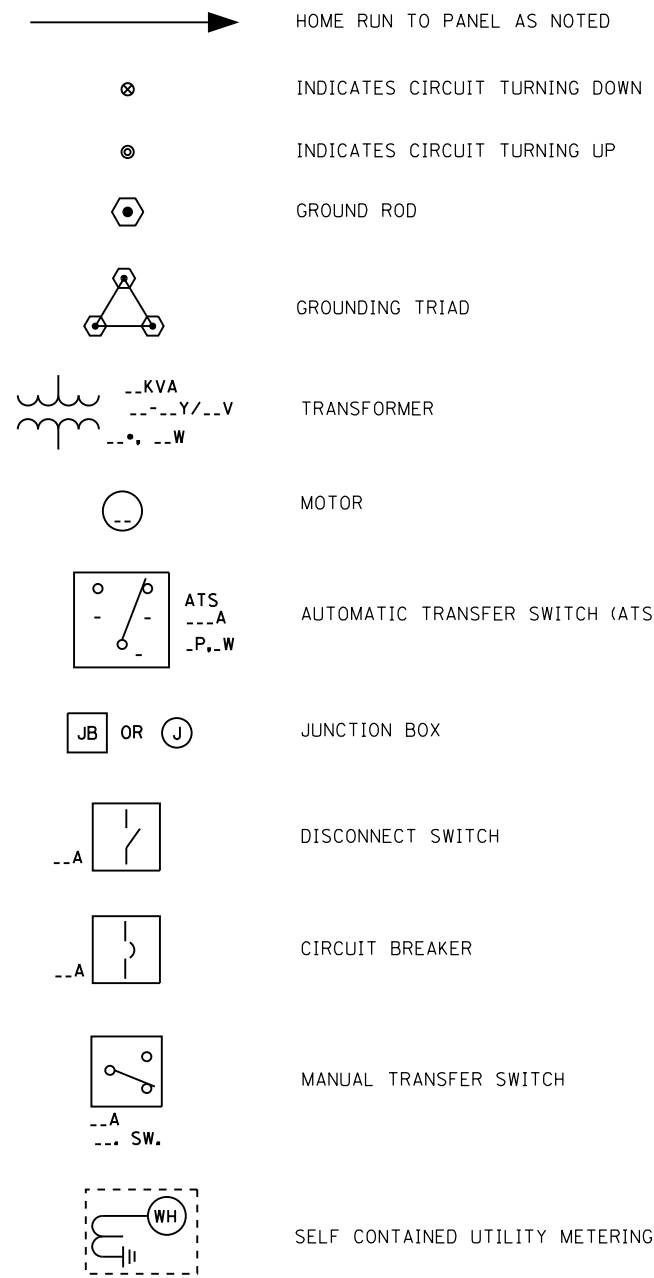

EXISTING

PROPOSED

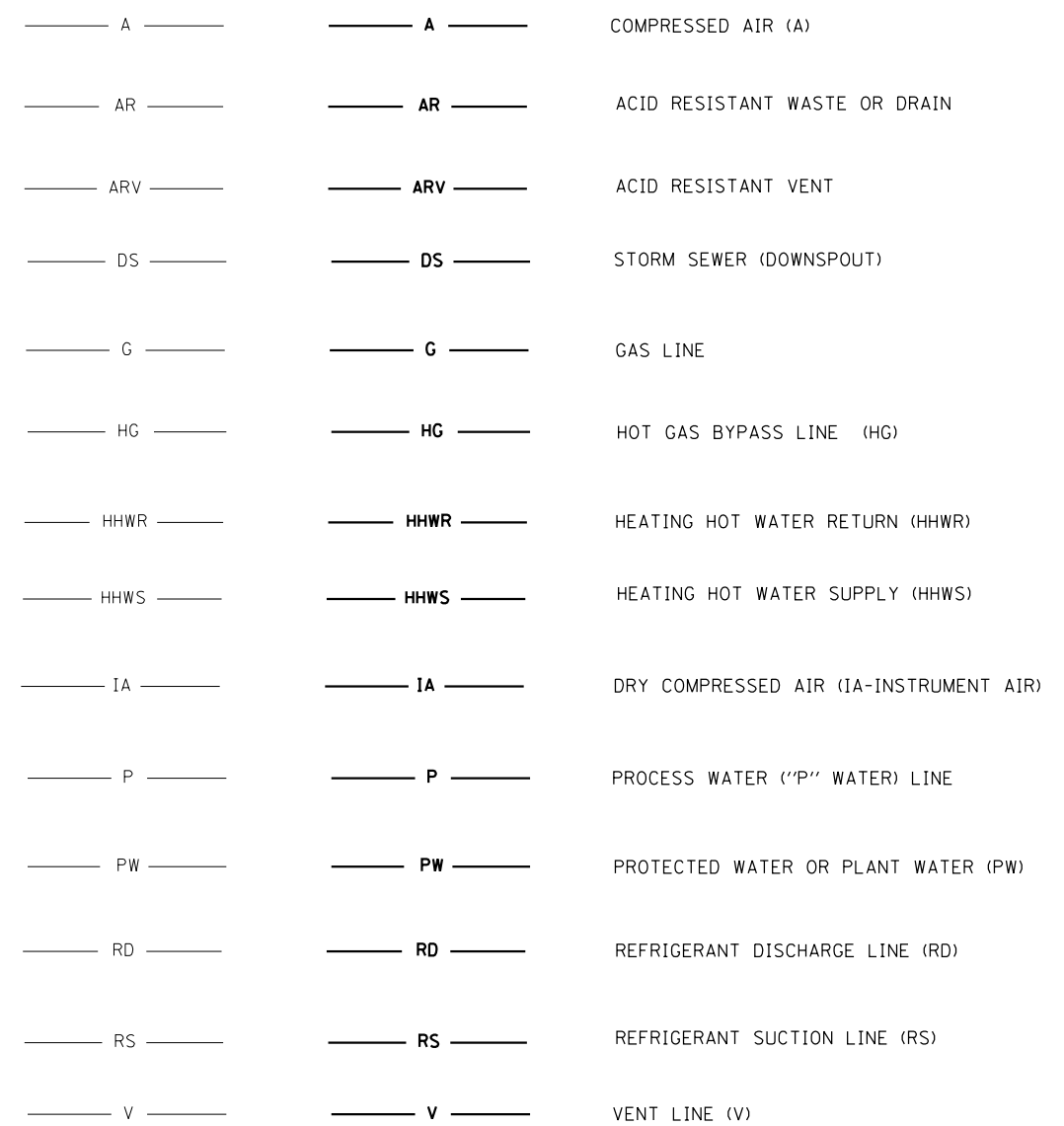

SYMBOLS AND PATTERNS











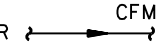
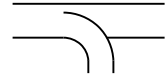

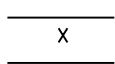
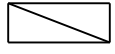





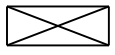

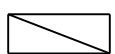
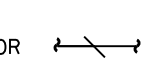

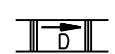
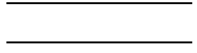



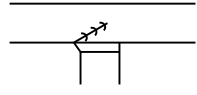
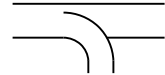







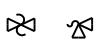
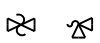

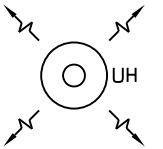
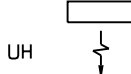

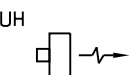
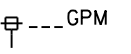
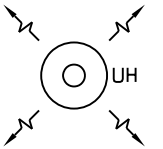

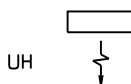









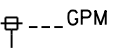



STANDARD D2-04

NOTE:

ALL SYMBOLS AND PATTERNS ON THIS DRAWING ARE PROPOSED UNLESS OTHERWISE NOTED.

Paul Kovacs
 APPROVED CHIEF ENGINEER DATE 7-1-2009

ELECTRICAL AND MECHANICAL ITEMS

	OR		QUANTITY AND DIRECTION OF THE AIR FLOW			
	OR		DUCT SIZE (FIRST FIGURE SIZE OF SHOWN, SECOND FIGURE SIZE OF SIDE NOT SHOWN.)			
			SUPPLY DUCT SECTION			
	OR		RETURN OR EXHAUST DUCT SECTION			
	OR		DUCT DROPS IN THE DIRECTION OF FLOW			
	OR		DUCT RISES IN THE DIRECTION OF FLOW			
	OR		TURNING VANES			
	OR		8" THROAT DIAMETER CEILING DIFFUSER; AIR FLOW -- 100 CFM			
	OR		BALANCING OR VOLUME DAMPER			
	OR		MOTOR OPERATED DAMPER			
			FLEXIBLE DUCT			
			FIRE DAMPER			
			SOUND ATTENUATOR			
			ZONE DAMPER			
			FLEXIBLE CONNECTION AT FAN OR EQUIPMENT			
			EXTRACTOR			
			OR		SPLITTER DAMPER	
					PLUG VALVE WITH MEMORY STOP (BALANCING)	
					PLUG VALVE	
					SOLENOID VALVE	
					TEMPERATURE CONTROL VALVE	
					THREE-WAY TEMPERATURE CONTROL VALVE DIAPHRAGM	
					THREE-WAY TEMPERATURE CONTROL VALVE TOP VIEW	
					PRESSURE REDUCING VALVE	
					(NOS. = INITIAL AND FINAL PRESSURE - PSIG)	
					AIR PRESSURE REDUCING STATION (NO. CORRESPONDS WITH AIR PRESSURE REDUCER SCHEDULE)	
					SAFETY VALVE	
					(NOS. = PRESSURE SETTING - PSIG)	
					FLOAT OPERATED VALVE	
					QUICK COUPLING (QC)	
					HORIZONTAL UNIT HEATER (NO. CORRESPONDS WITH UNIT HEATER SCHEDULE)	
					VERTICAL UNIT HEATER (NO. CORRESPONDS WITH UNIT HEATER SCHEDULE)	
					CABINET TYPE UNIT HEATER (NO. CORRESPONDS WITH UNIT HEATER SCHEDULE)	
					THERMOSTAT OR ROOM TEMPERATURE SENSOR	
					GATE VALVE	
					FLOW SWITCH	
					VENTURI FLOW METER AND FLOW TO BE INDICATED	
					CONNECTION BETWEEN NEW AND EXISTING	
					GLOBE VALVE	
					BUTTERFLY VALVE	
					CHECK VALVE	
					ANGLE GATE VALVE	
					CONCENTRIC REDUCER	
					ECCENTRIC REDUCER	
					ORIFICE FLANGE	
					CROSSOVER	
					PIPE GUIDE	
					EXPANSION JOINT (SLIP TYPE)	
					EXPANSION JOINT (BELLOWS TYPE)	
					AIR ELIMINATOR (AIR VENT)	
					PIPE CAP	
					STRAIGHT CROSS	
					90° ELBOW	
					90° ELBOW TURNED DOWN	
					90° ELBOW TURNED UP	
					SIDE OUTLET ELBOW TURNED DOWN	
					SIDE OUTLET ELBOW TURNED UP	
					LATERAL	
					TEE	
					TEE OUTLET UP	
					TEE OUTLET DOWN	
					UNION	
					STRAINER	
					PIPE ANCHOR	
					THERMOMETER (NOS. = RANGE IN DEGREES FAHRENHEIT)	
					PRESSURE, VACUUM OR COMPOUND GAUGE	



SYMBOLS AND PATTERNS

STANDARD D2-04

NOTE:

ALL SYMBOLS AND PATTERNS ON THIS DRAWING ARE PROPOSED UNLESS OTHERWISE NOTED.

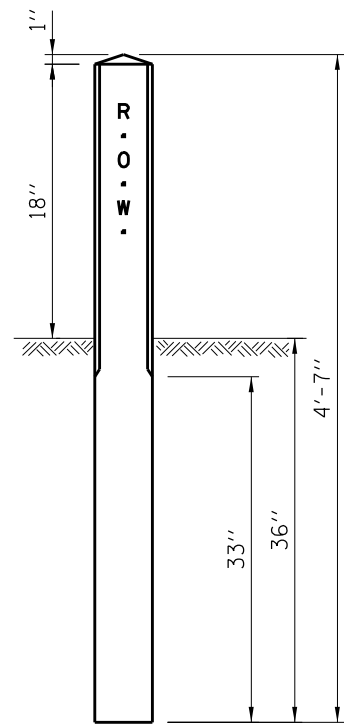

 APPROVED CHIEF ENGINEER DATE 7-1-2009

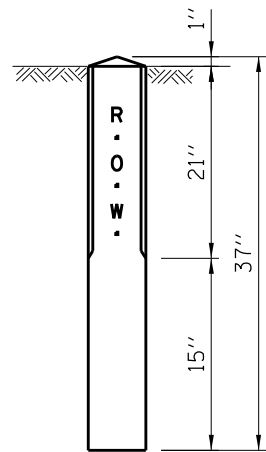

RIGHT OF WAY MARKER

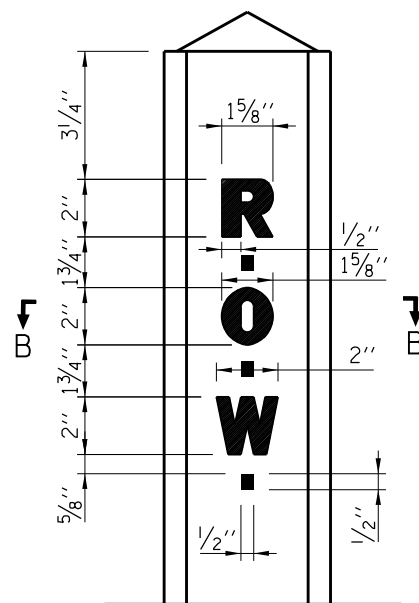

RIGHT OF WAY MARKER (SPECIAL)



LETTERING DETAIL

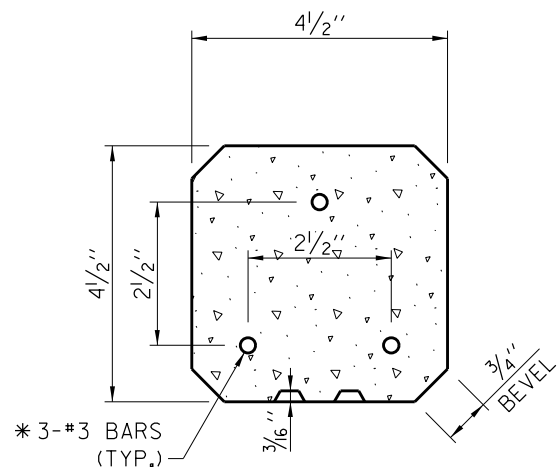

* METHOD A- 4'-2" LONG BARS
* METHOD B- 2'-6" LONG BARS
SECTION B-B

RIGHT OF WAY MARKER

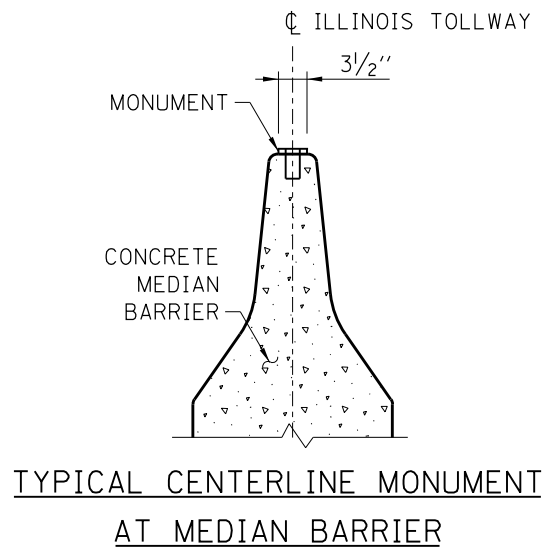

TYPICAL CENTERLINE MONUMENT
AT MEDIAN BARRIER

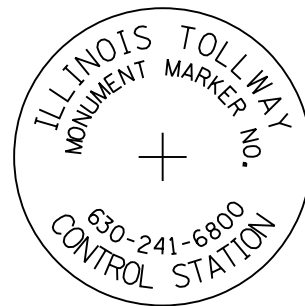

TOP VIEW

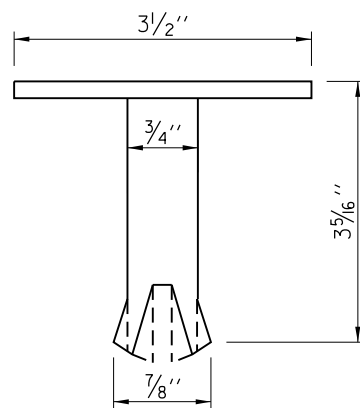

BRONZE DOMED CAP

PERMANENT SURVEY MONUMENT

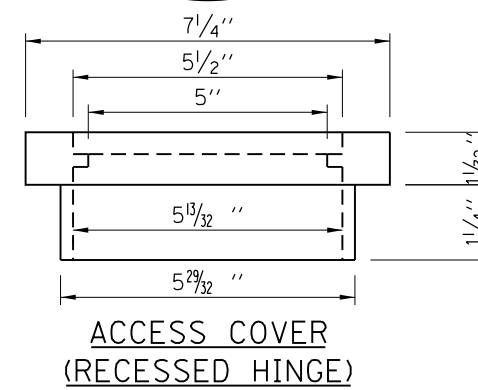

ACCESS COVER
(RECESSED HINGE)

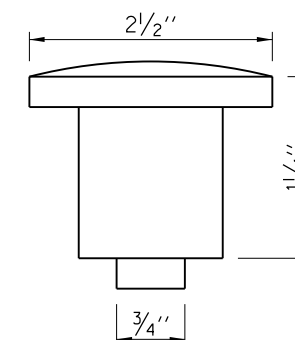
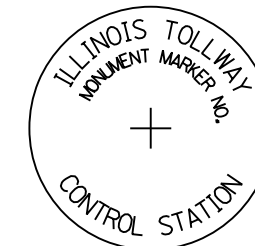

ALUMINUM DOMED CAP

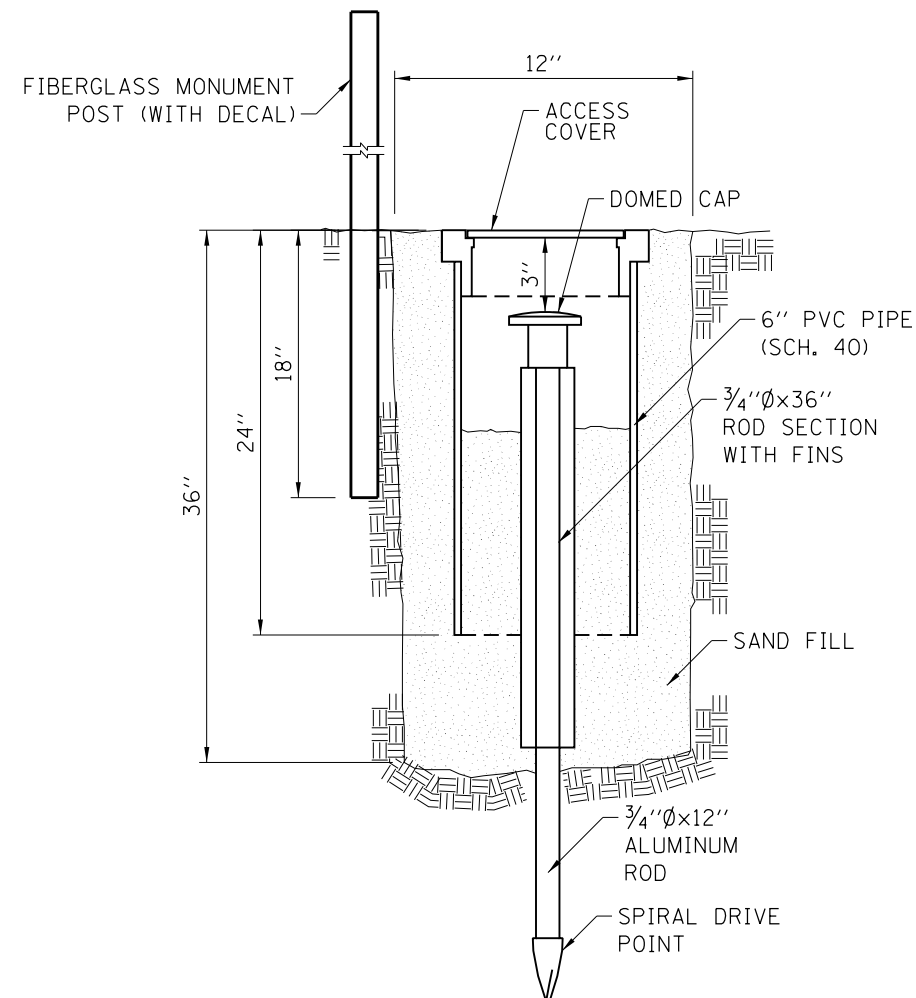

PERMANENT SURVEY MONUMENT (SPECIAL)

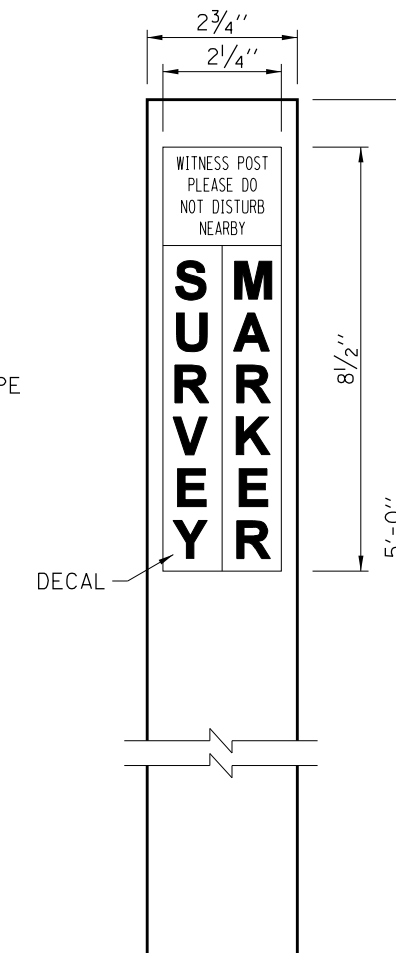

MONUMENT POST

PERMANENT SURVEY MONUMENT

APPROVED *Paul Kovacs* CHIEF ENGINEER DATE 1-1-2007

DATE	REVISIONS
07-01-10	NEW MONUMENT AND BARRIER MARKERS

Illinois Tollway

PERMANENT SURVEY MONUMENTS AND RIGHT-OF-WAY MARKERS
STANDARD D3-01

PERMANENT DELINEATION SPACING				
REFLECTORS	MAINLINE		RAMP	
	TANGENT	CURVE	TANGENT	CURVE
* GUARDRAIL	100'	100'	100'	100' (R >= 1,050') 50' (R < 1,050')
* BARRIER WALL (DOUBLE FACE)	100'	100'	100'	100' (R >= 1,050') 50' (R < 1,050')
* BARRIER WALL (SINGLE FACE)	100'	100'	100'	100' (R >= 1,050') 50' (R < 1,050')
SHOULDER NARROWING	3 @ 15'	3 @ 15'	3 @ 15'	3 @ 15'
BRIDGE APPROACHES	3 @ 15'	3 @ 15'	3 @ 15'	3 @ 15'
* BRIDGE PARAPET	50'	50'	50'	50'
* NOISE ABATEMENT WALL (CRASH WORTHY)	100'	100'	100'	100' (R >= 1,050') 50' (R < 1,050')
ROADWAY DELINEATORS	MAINLINE		RAMP	
	TANGENT	CURVE	TANGENT	CURVE
POST MOUNTED DELINEATOR	200'	200'	200'	TABLE A
POST MOUNTED DELINEATOR (RAMP TAPERS AND TANGENTS)	100'	100'	NA	NA
TEMPORARY DELINEATION SPACING				
	TANGENT	REVERSE CURVE	SHIFT	TAPER
TEMPORARY CONCRETE BARRIER	50'	25'	25'	25'
* WHEN ADJACENT SHOULDER IS USED AS A TRAVELED LANE, USE SPACING REQUIREMENTS AS SHOWN FOR TEMPORARY DELINEATION.				

TABLE A	
REFLECTOR SPACING ON RAMP-CURVES	
RADIUS OF CURVE (FT.)	SPACING ALONG CURVE (FT.)
LESS THAN 1050	50
1050-1299	100
1300-1999	125
2000-2999	150
3000-3999	175
MORE THAN 3999	200

GENERAL NOTES:

EMERGENCY TURNAROUNDS DELINEATION-THE FOLLOWING DELINEATION SHOULD BE INSTALLED ON THE LEFT SIDE OF THE PAVEMENT APPROACHING EMERGENCY TURNAROUNDS.

- A. ONE-HALF OF A MILE IN ADVANCE OF THE EMERGENCY TURNAROUNDS ONE WHITE REFECTOR UNIT OVER THREE AMBER REFLECTOR UNITS.
- B. ONE-FOURTH OF A MILE IN ADVANCE OF THE EMERGENCY TURNAROUNDS ONE WHITE REFLECTOR UNIT OVER TWO AMBER REFLECTOR UNITS.
- C. AT A POINT NEAR THE INTERSECTION OF THE EDGE OF THE LEFT SHOULDER AND NEAR EDGE OF THE EMERGENCY TURNAROUNDS ONE WHITE REFLECTOR UNIT OVER ONE AMBER REFLECTOR UNIT.

NOTES FOR ROADWAY DELINEATORS, POST MOUNTED INSTALLATION:

1. A. MAINLINE-SINGLE WHITE REFECTOR UNITS SHALL BE PLACED CONTINUOUSLY ON THE RIGHT AND SINGLE AMBER REFLECTOR UNITS SHALL BE PLACED ON THE LEFT ON MAIN LINE SECTIONS WITHOUT BARRIER WALL.
- B. RAMPS-SINGLE REFLECTOR UNITS SHALL BE PLACED ON THE OUTSIDE OF ALL CURVED SECTIONS OF RAMPS, SINGLE WHITE SHALL BE PLACED ON THE RIGHT SIDE AND AMBER ON THE LEFT SIDE. THE DELINEATORS SHALL BE OVERLAPPED FOR A SHORT DISTANCE TO CLEARLY INDICATE WHERE DELINEATION ON ONE SIDE OF THE RAMP ENDS AND DELINEATION ON THE OTHER SIDE APPEARS.
- C. DOUBLE WHITE REFLECTOR UNITS SHALL BE PLACED ON THE RIGHT AT ALL ACCELERATION AND DECELERATION LANES.
2. REFLECTORS SHALL BE MOUNTED ON SUPPORTS SUCH THAT THE TOP OF REFLECTORS IS FOUR FEET ABOVE THE ROADWAY EDGE AND TWO FEET OUTSIDE THE OUTER EDGE OF THE PAVED SHOULDER OR TWO FEET MINIMUM AND SIX FEET MAXIMUM OUTSIDE THE BACKS OF CURBS OR GUTTERS.
3. IN ALL CASES, THE COLOR OF THE REFLECTORS SHALL BE THE SAME AS THE ADJACENT EDGE LINE EXCEPT AS SPECIFIED IN GENERAL NOTES.
4. POST MOUNTED REFLECTORS SHALL BE PLACED CONTINUOUSLY AS NOTED ABOVE IN CONJUNCTION WITH GUARDRAIL INSTALLED.
5. THE PLACEMENT OF ROADWAY DELINEATOR "CIRCULAR REFLECTORS" SHALL BE USED FOR ALL MINOR PROJECTS WHICH HAVE A LENGTH OF LESS THAN 5 MILES. THE PLACEMENT OF ROADWAY DELINEATOR "RECTANGULAR REFLECTORS" SHALL BE USED FOR ALL MAJOR PROJECTS WHICH HAVE A LENGTH GREATER THAN 5 MILES. ALL ROADWAY DELINEATORS WITHIN A ROADWAY SEGMENT SHALL BE OF THE SAME TYPE.

NOTES FOR GUARDRAIL AND BARRIER WALL REFLECTOR:

1. REFLECTORS TYPE B AND TYPE C SHALL HAVE REFLECTIVE SURFACE ON ONE SIDE ONLY.



ROADWAY DELINEATORS AND REFLECTORS

STANDARD D4-06

DATE	REVISIONS
07-01-09	CHANGED BARRIER TO F-SHAPE CONFIG. ADDED SECTION C-C NEW BARRIER DELINEATORS
02-07-12	REVISED REFLECTOR MARKER TYPE C DIMENSION
11-01-12	REVISED NOTES, TABLE AND DELINEATION SPACING
3-11-2015	REVISED NOTES
3-31-2016	REVISED DELINEATOR ATTACHMENT TO POST
3-31-2017	REVISED PERM. DELINEATION SPACING TABLE

APPROVED *Paul Kovacs* CHIEF ENGINEER DATE 7-1-2009

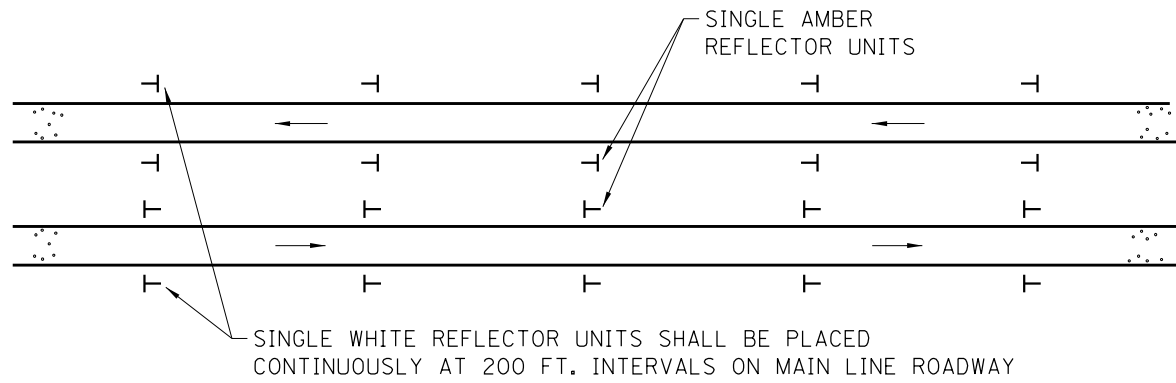

TANGENT PLACEMENT

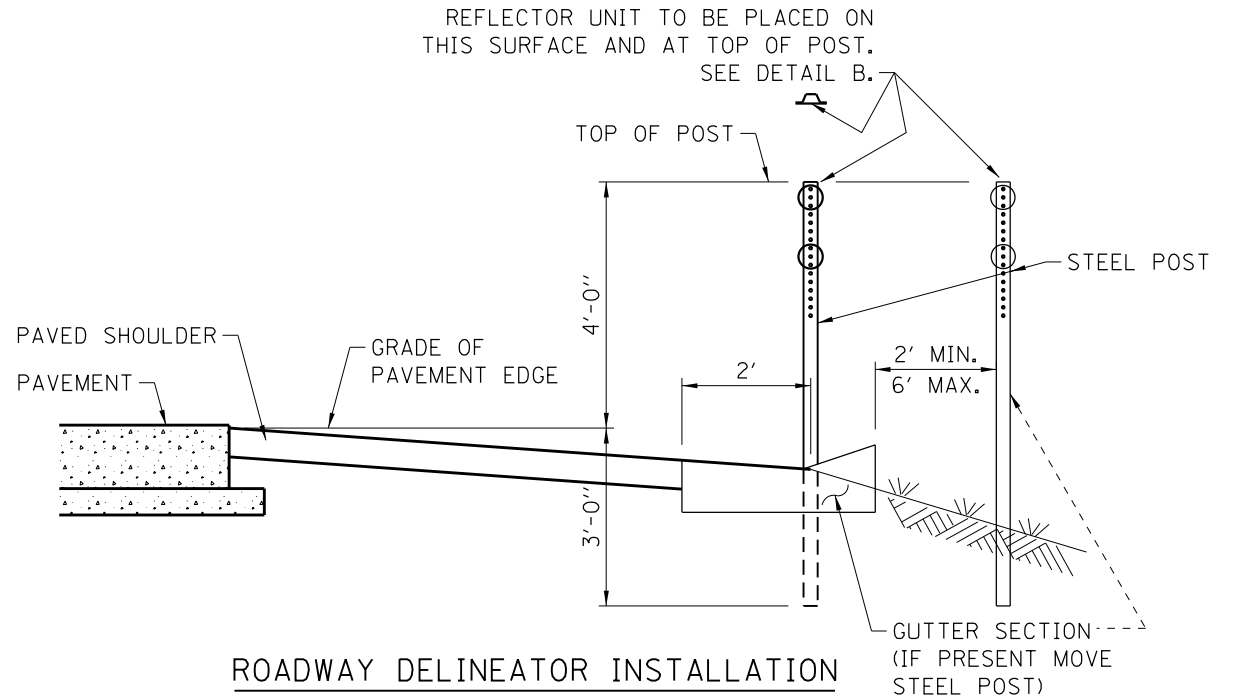

ROADWAY DELINEATOR INSTALLATION

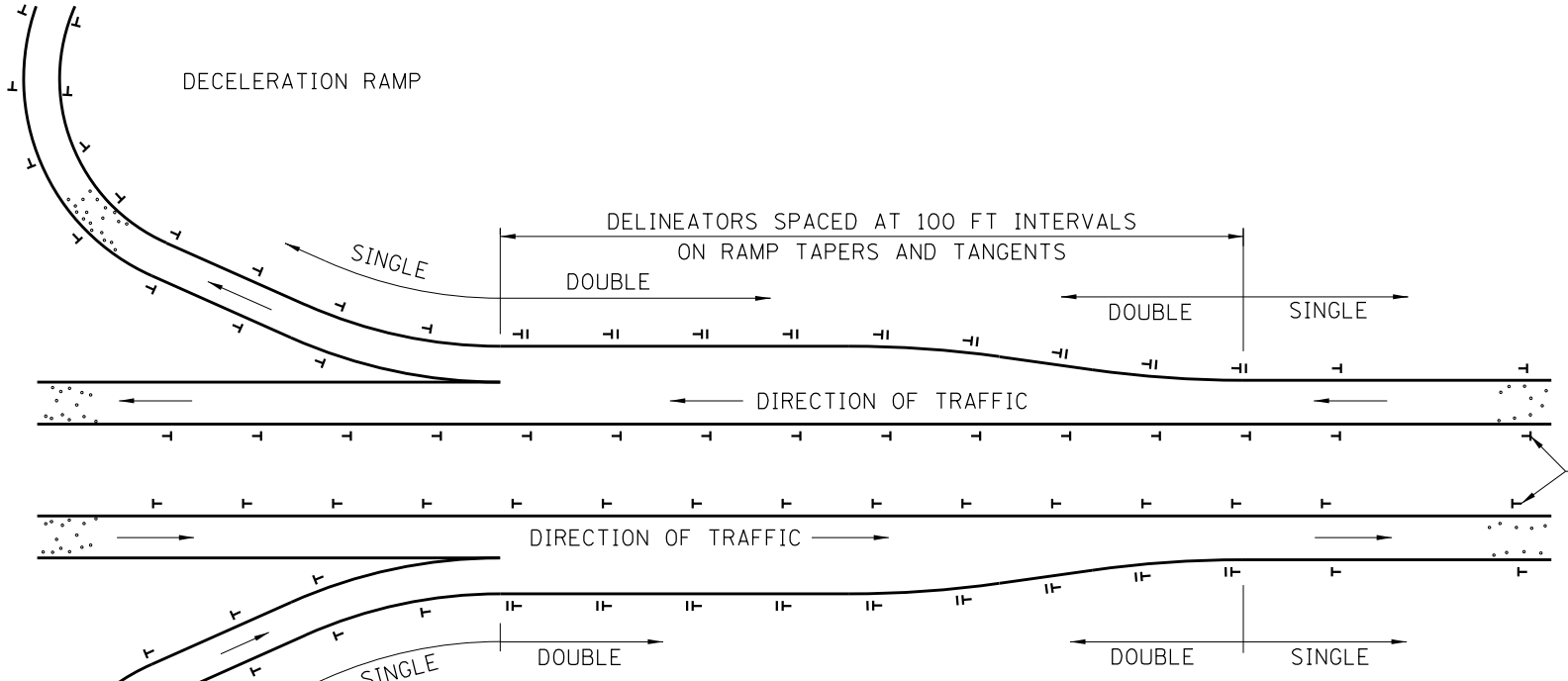

INTERCHANGE RAMP PLACEMENT

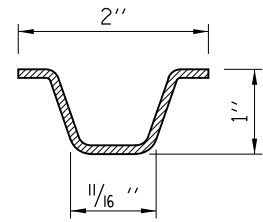

SECTION A-A
STEEL- 1.12 LBS/FT.

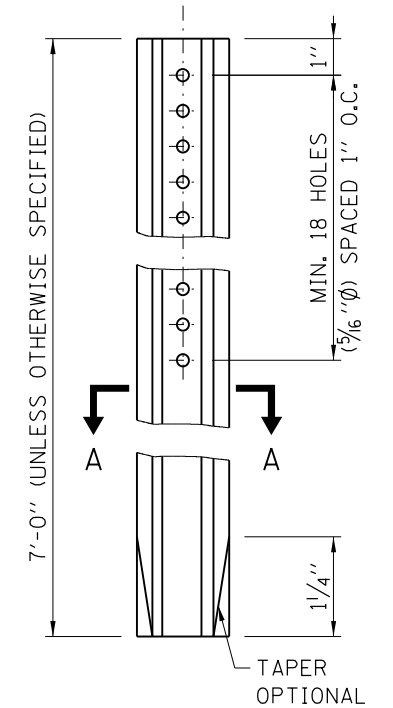

STEEL POST

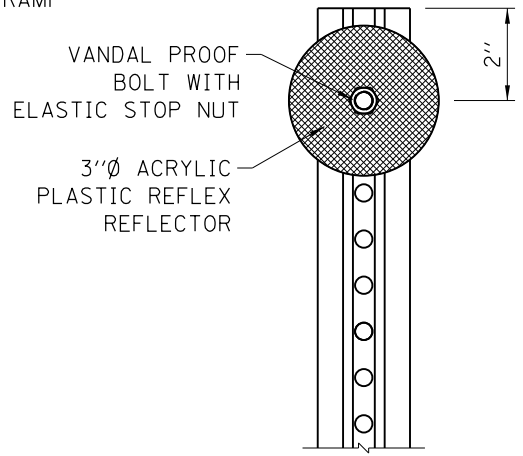

SINGLE UNIT

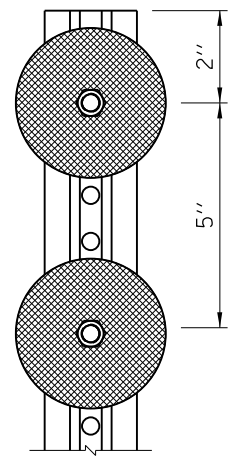

DOUBLE UNIT

CIRCULAR REFLECTORS

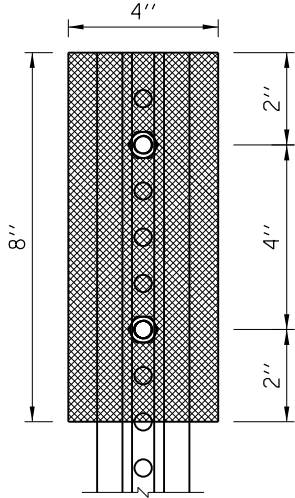

SINGLE UNIT

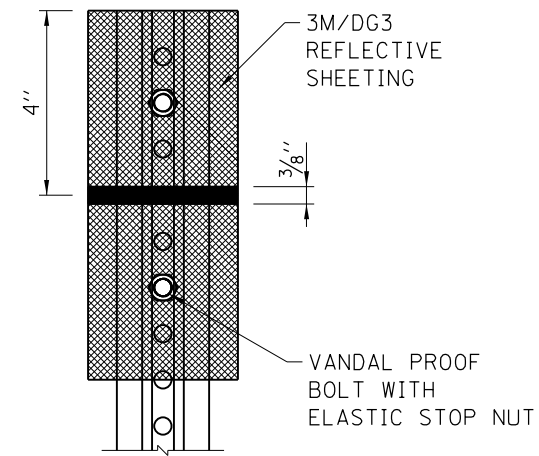

DOUBLE UNIT

RECTANGULAR REFLECTORS

NOTE:
SEE SHEET 1 OF THIS SERIES FOR NOTES.

APPROVED *Paul Kovacs* CHIEF ENGINEER DATE 7-1-2009

SHEET 2 OF 3

ROADWAY DELINEATORS AND REFLECTORS

STANDARD D4-06

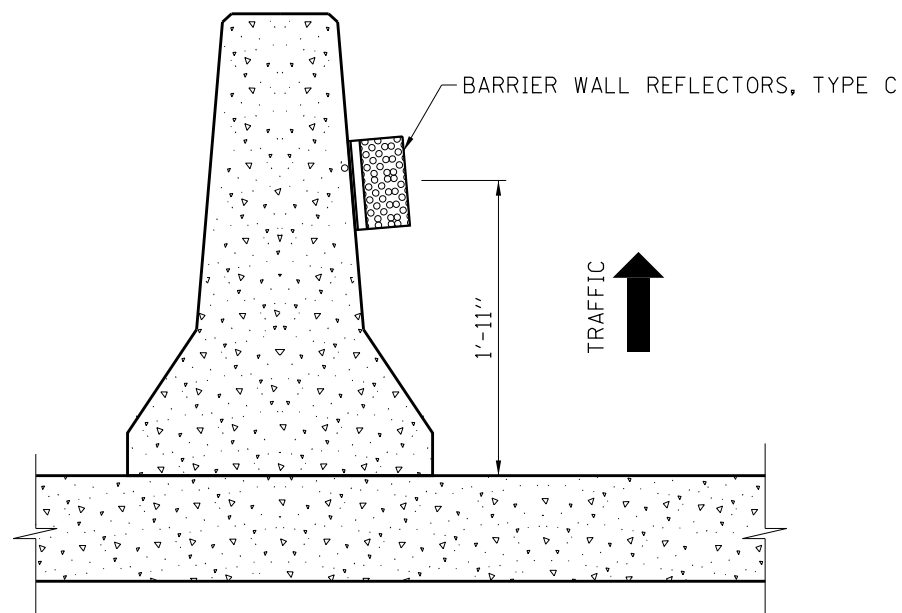

CROSS-SECTION

TEMPORARY CONCRETE BARRIER

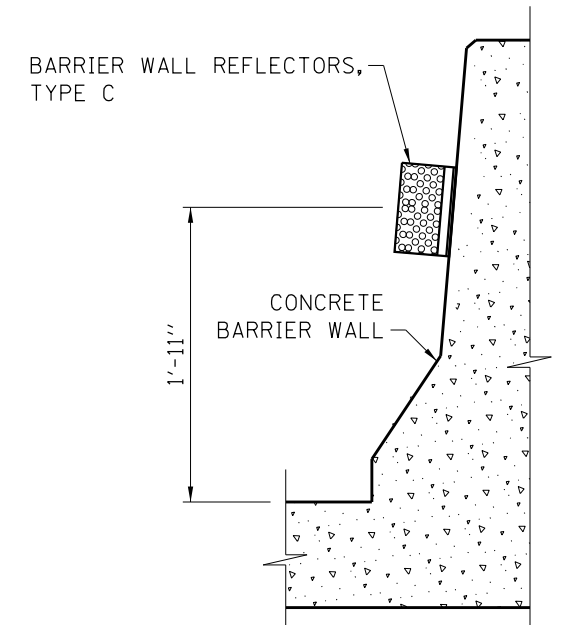

BARRIER OR PARAPET REFLECTOR INSTALLATION

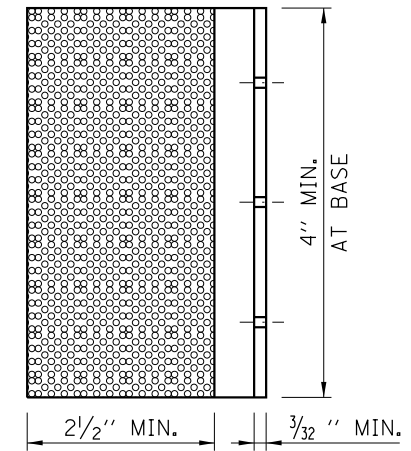

REFLECTOR, TYPE C

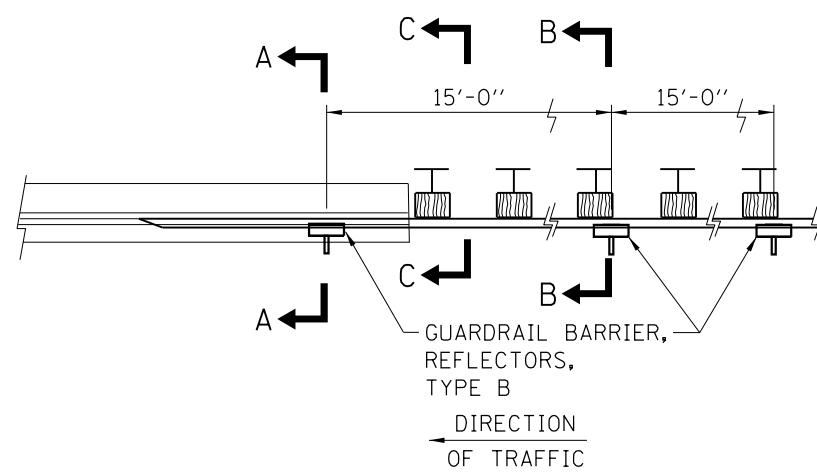

PLAN

REFLECTOR INSTALLATION ON GUARDRAIL AT BRIDGE APPROACHES

ALSO SEE SHEET 1 IN THIS SERIES FOR ADDITIONAL INFORMATION

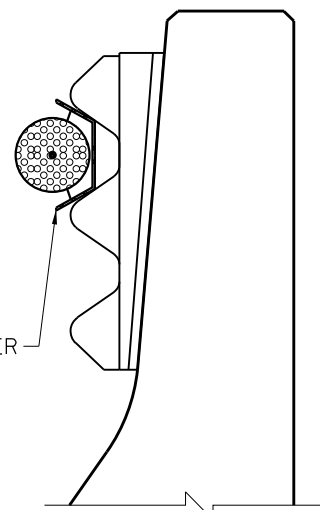

SECTION A-A

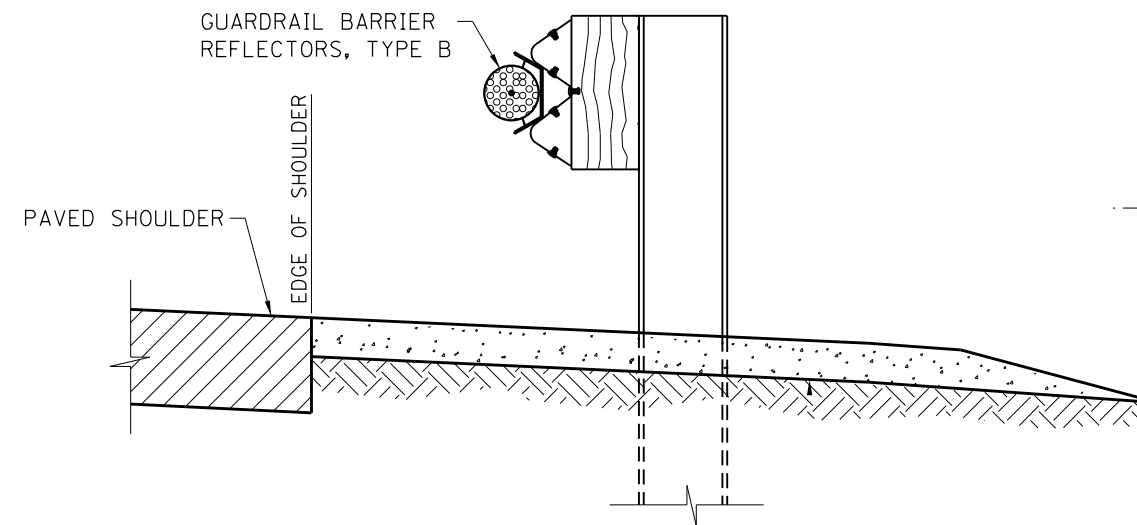

SECTION B-B

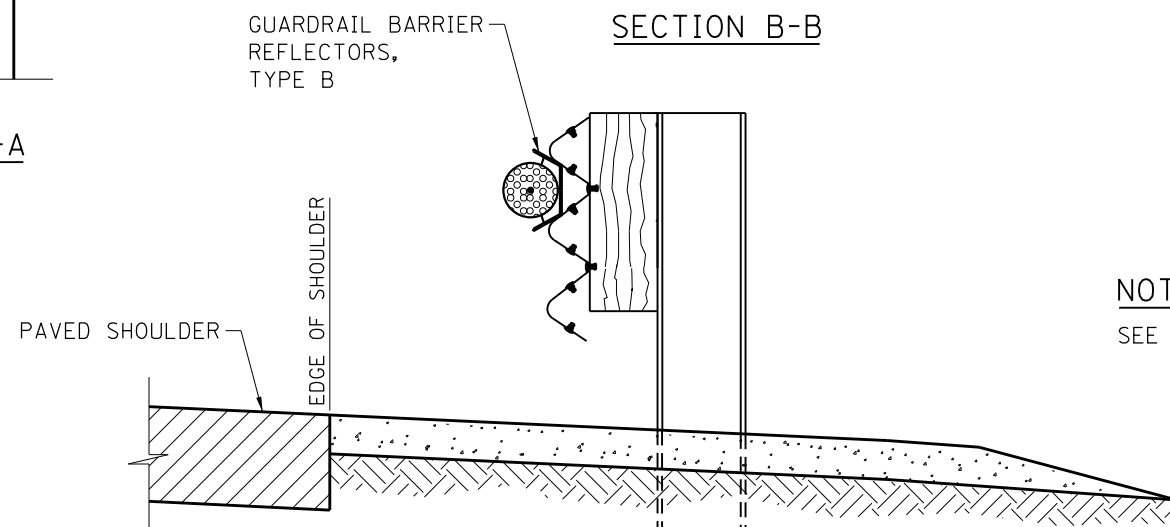

SECTION C-C

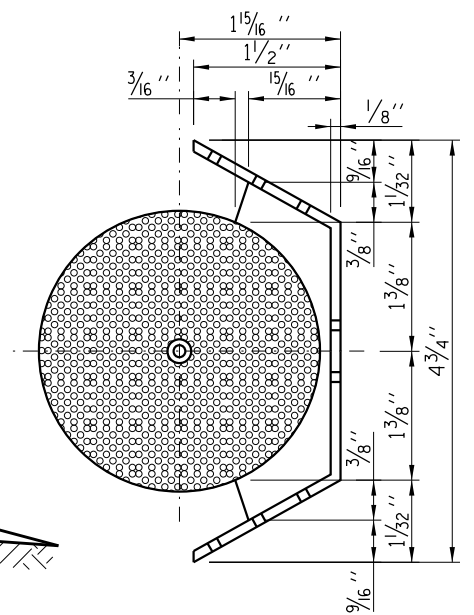

REFLECTOR, TYPE B

NOTE:
SEE SHEET 1 OF THIS SERIES FOR NOTES.

SHEET 3 OF 3



ROADWAY DELINEATORS AND REFLECTORS

STANDARD D4-06

APPROVED *Paul Kovacs* CHIEF ENGINEER DATE 7-1-2009

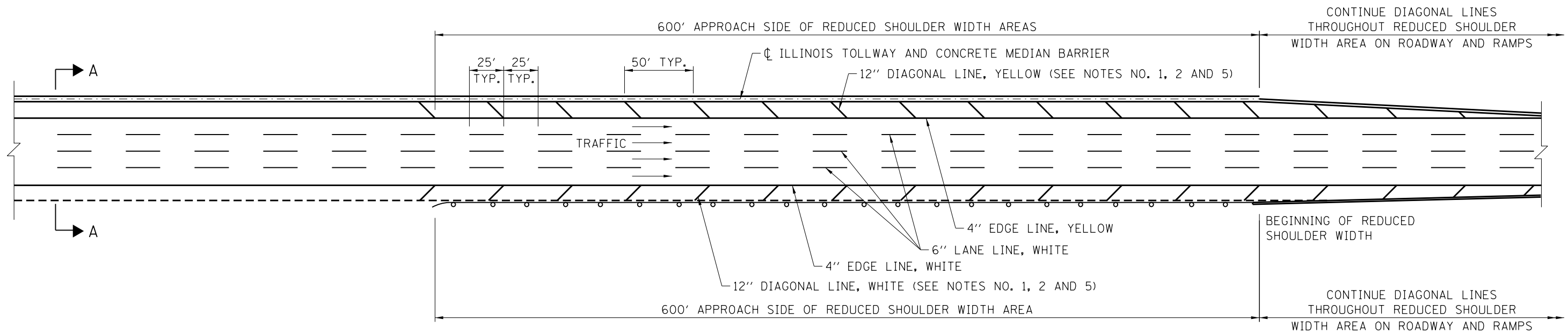

PLAN

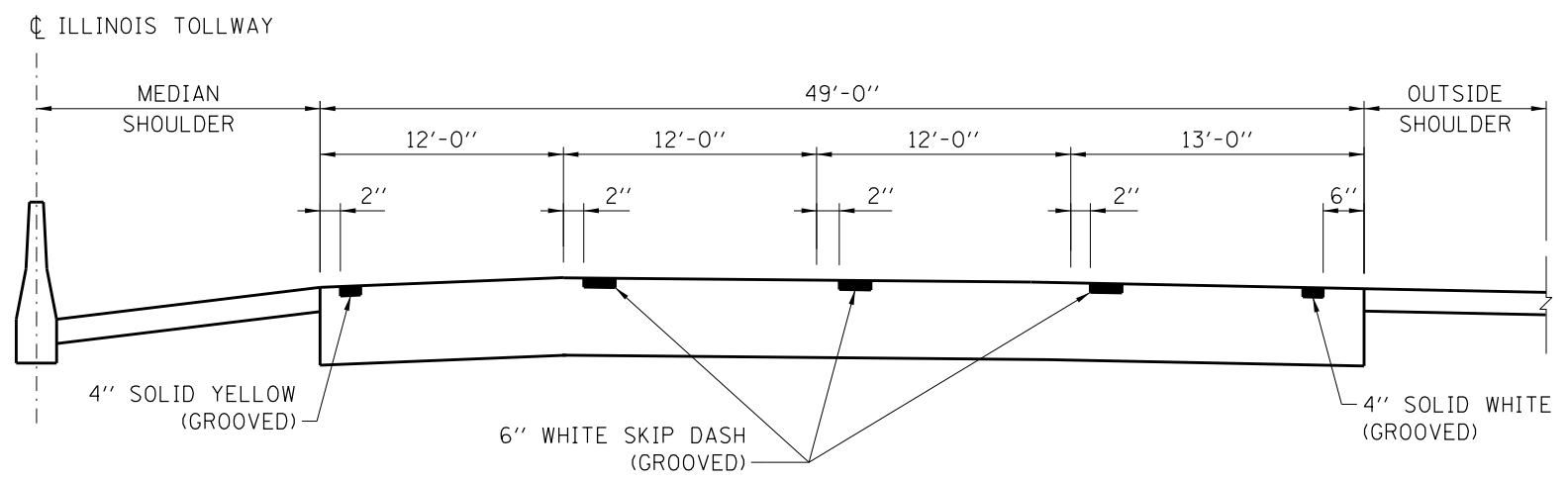

SECTION A-A

ROADWAY AND SHOULDER STRIPING - NEW CONSTRUCTION

GENERAL NOTES:

1. DIAGONAL SHOULDER STRIPING REQUIRED WHERE THE SHOULDER WIDTH IS LESS THAN STANDARD.
2. ROADWAY MARKING MATERIALS TO BE USED ON FINISHED CONCRETE SURFACE AND ASPHALT SURFACE SHALL BE AS SHOWN ON THE PLANS.
3. WHERE THE GUARDRAIL ENCLOSES ON THE SHOULDER THE DIAGONAL MARKINGS SHALL EXTEND AS CLOSE TO THE FACE OF THE RAIL AS POSSIBLE.
4. ALL PERMANENT LANE LINES AND EDGE LINES SHALL BE GROOVED, ON ROADWAY SURFACES, UNLESS OTHERWISE NOTED.
5. DIAGONAL STRIPING SHALL BE SURFACE APPLIED.
6. GORE STRIPING (CHEVRON) SHALL BE SURFACE APPLIED.
7. ALL LANE LINES AND EDGE LINES SHALL BE SURFACE APPLIED ON BRIDGES.
8. PAVEMENT MARKINGS SHALL NOT BE GROOVED AT THE CASH SIDE OF MAINLINE TOLL PLAZAS OR THE OPEN ROAD TOLLING (ORT), 100' CONTINUOUSLY REINFORCED CONCRETE (CRC) PAVEMENT SECTION OF MAINLINE UNDER MONOTUBES.

APPROVED *Paul Kovacs* CHIEF ENGINEER DATE 7-1-2009

DATE	REVISIONS
7-01-09	ADDED LINE GROOVING NOTES
2-07-12	REVISED NOTES
11-01-12	REVISED EDGELINE OFFSET, REVISED NOTES
3-31-14	REVISED NOTES
3-31-16	REVISED NOTES

PERMANENT PAVEMENT MARKINGS

STANDARD D5-06

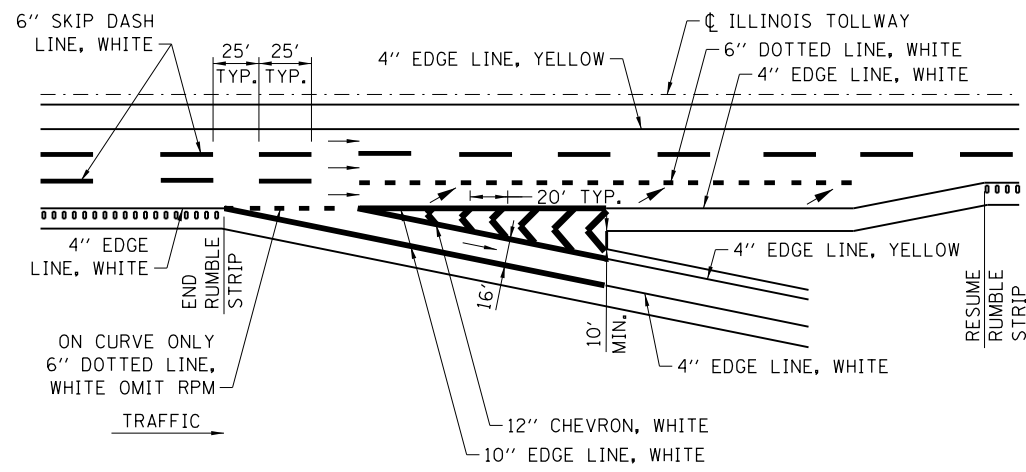

EXIT - SINGLE LANE RAMP
LANE THREE TERMINATION

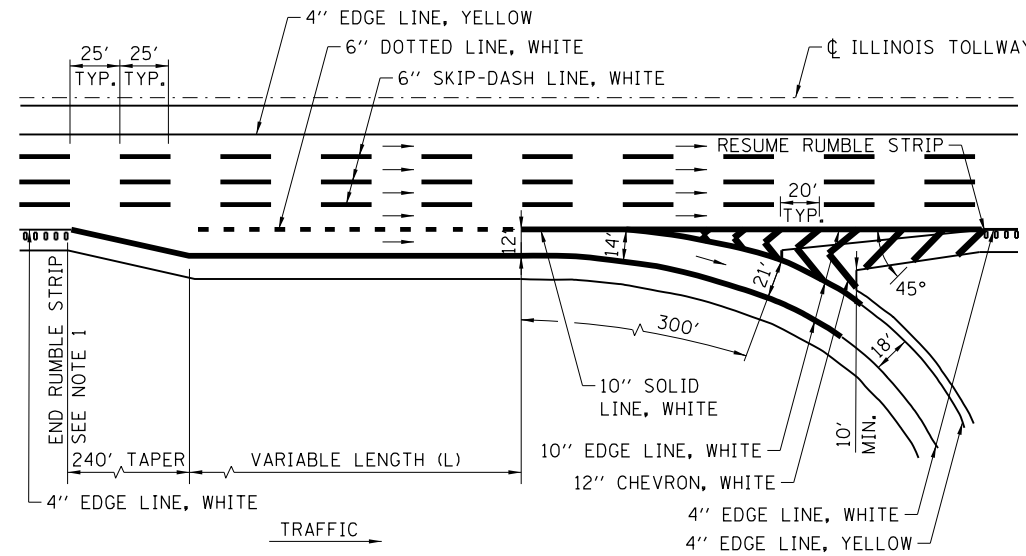

EXIT - SINGLE LANE LOOP RAMP - PARALLEL TYPE

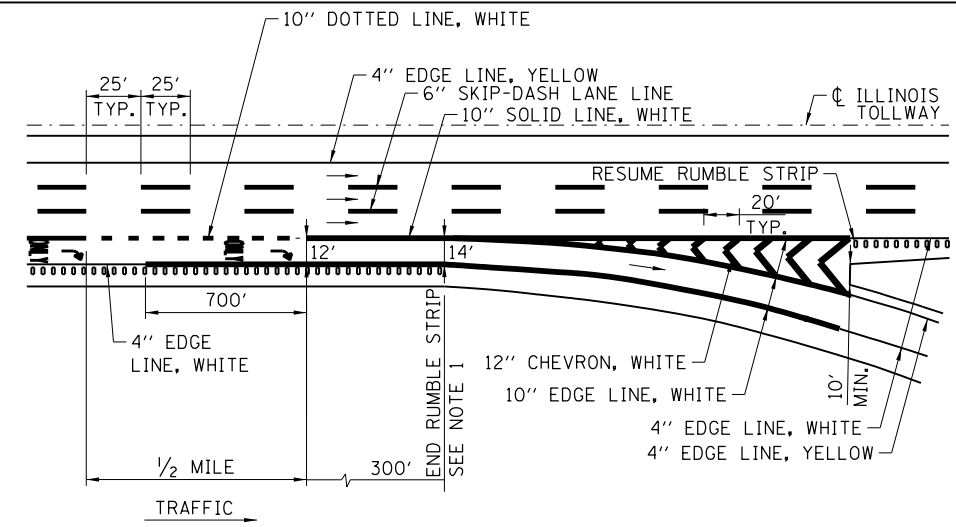

EXIT - SINGLE LANE RAMP - LANE DROP

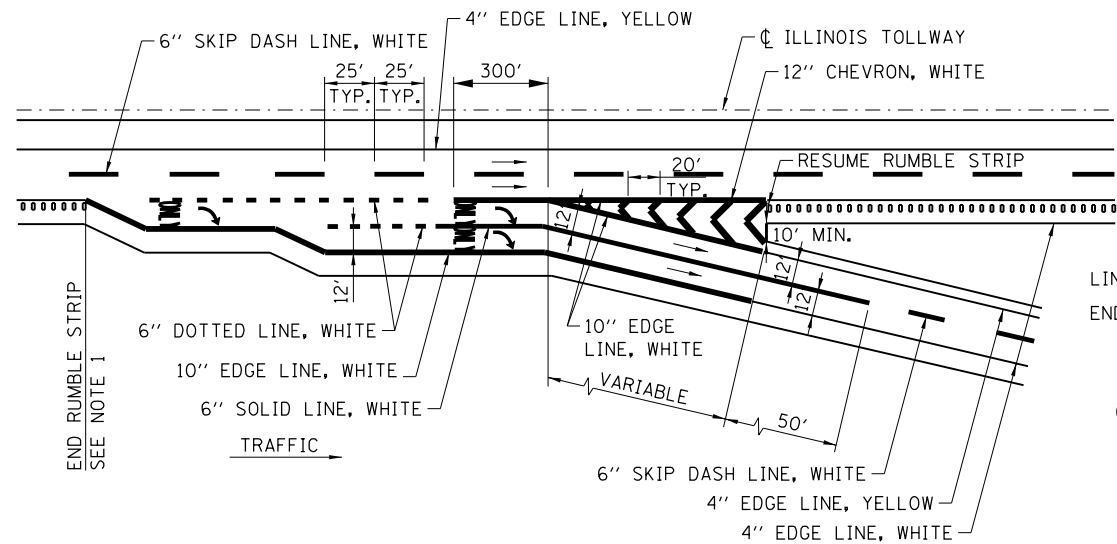

EXIT - TWO LANE PARALLEL RAMP

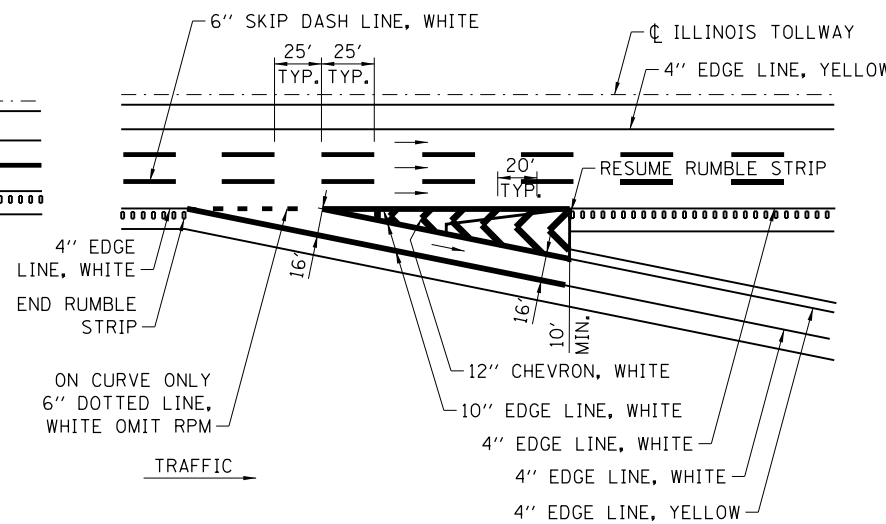

EXIT - SINGLE LANE RAMP - TAPER TYPE

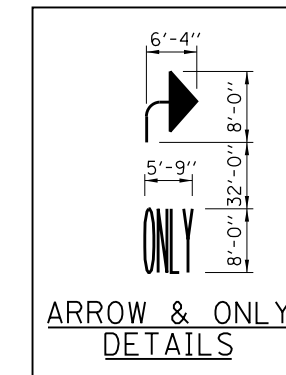

NOTE:
PAVEMENT MARKING LETTERS AND SYMBOLS-ONLY AND ARROW ARE TO BE TYPICALLY PLACED AT 1/2 MILE EXIT ONLY GUIDE SIGN, AT GORE EXIT GUIDE SIGN AND APPROXIMATELY HALFWAY BETWEEN THE TWO.

GENERAL NOTES:

1. RUMBLE STRIPS SHALL BE INSTALLED BETWEEN THE THEORETICAL GORE AND TAPER WHEN LENGTHS (L) OF AUXILIARY LANES, ACCELERATION LANES OR DECELERATION LANES, ARE GREATER THAN 1000'.
2. ROADWAY MARKING MATERIALS TO BE USED ON FINISHED CONCRETE SURFACE AND ASPHALT SURFACE SHALL BE AS SHOWN ON THE PLANS.
3. ALL LANE LINES AND EDGE LINES SHALL BE GROOVED.
4. GORE STRIPING (CHEVRON) SHALL BE SURFACE APPLIED.
5. LETTERS AND SYMBOL MARKING SHALL BE SURFACE APPLIED.
6. DOTTED LINES SHALL CONSIST OF 3' LINE AND 9' GAPS.

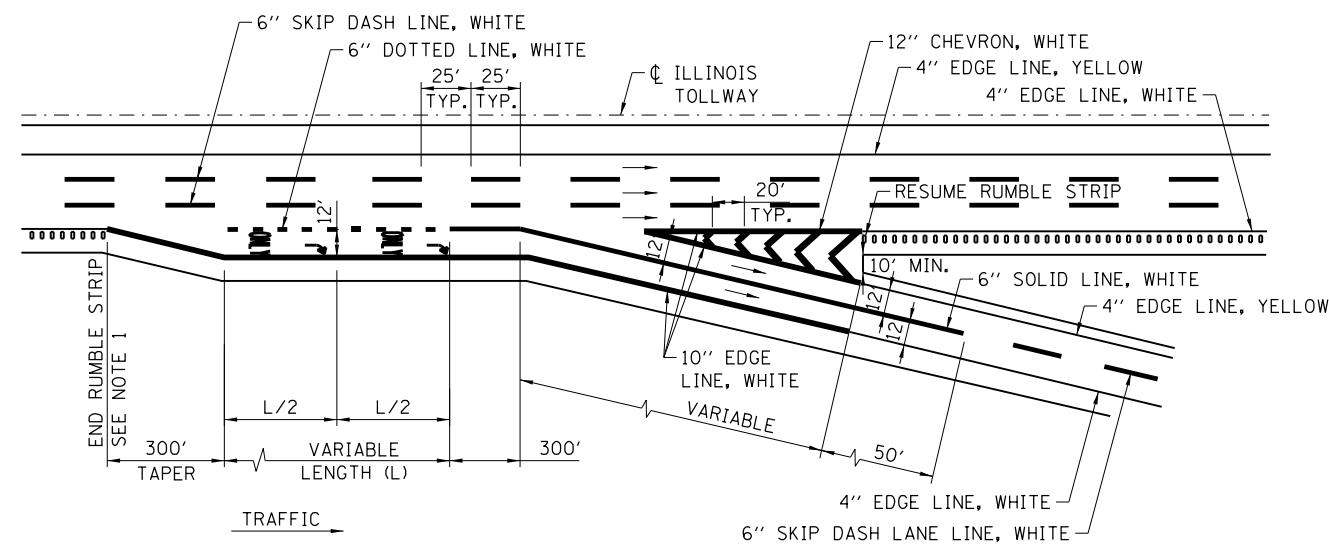

EXIT - TWO LANE RAMP

APPROVED *Paul Kovacs* CHIEF ENGINEER DATE 7-1-2009



DATE	REVISIONS
11-01-12	REVISED NOTES AND ADDED DOTTED LINE
03-01-13	REVISED SINGLE LANE LOOP RAMP DETAILS
03-31-14	ADDED LANE REDUCTION MARKINGS
3-11-2015	REVISED DETAILS, ADDED LANE-REDUCTION ARROWS AND SHEET 3
3-31-2016	REVISED NOTES, ADDED IPO PAVEMENT MARKING DETAIL.
3-31-2017	REVISED NOTES

PAVEMENT MARKING AND SHOULDER RUMBLE STRIP DETAILS
STANDARD D6-07

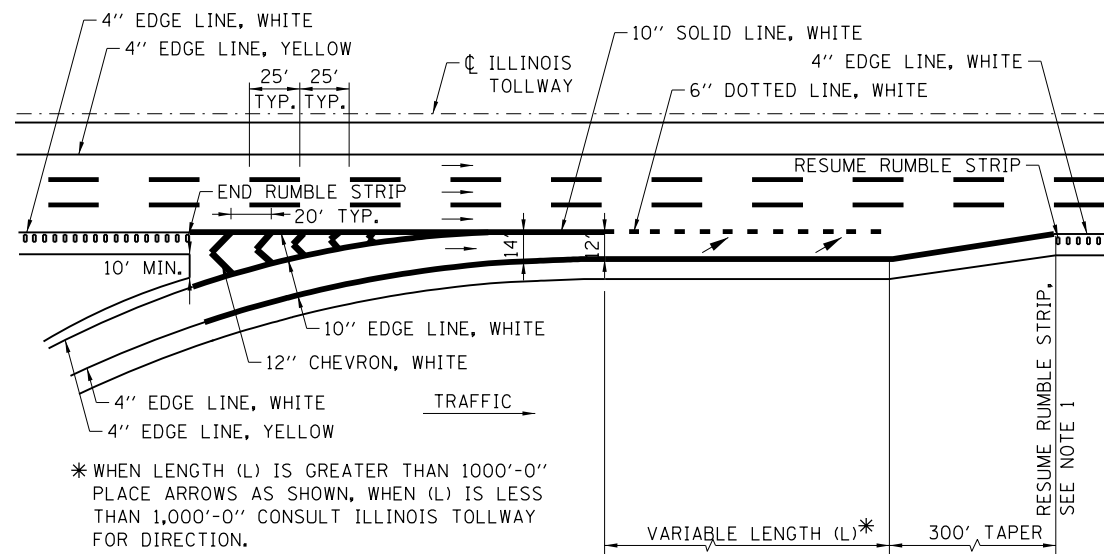

ENTRANCE - SINGLE LANE RAMP - PARALLEL TYPE

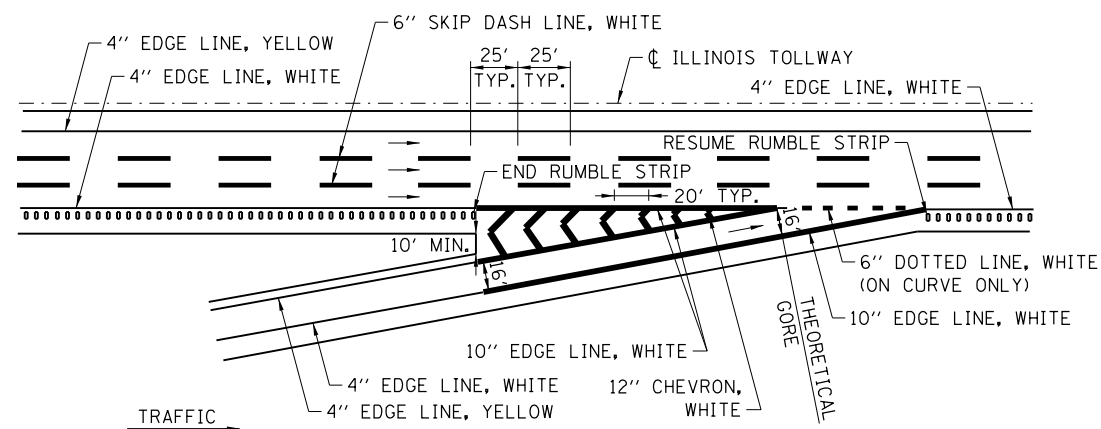

ENTRANCE - SINGLE LANE RAMP - TAPER TYPE

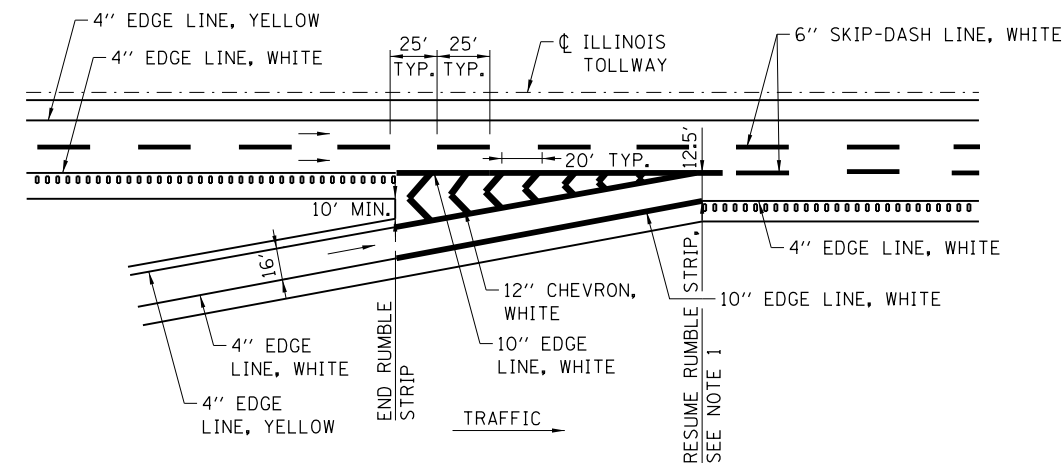

ENTRANCE - SINGLE LANE RAMP WITH ADDED MAINLINE LANE

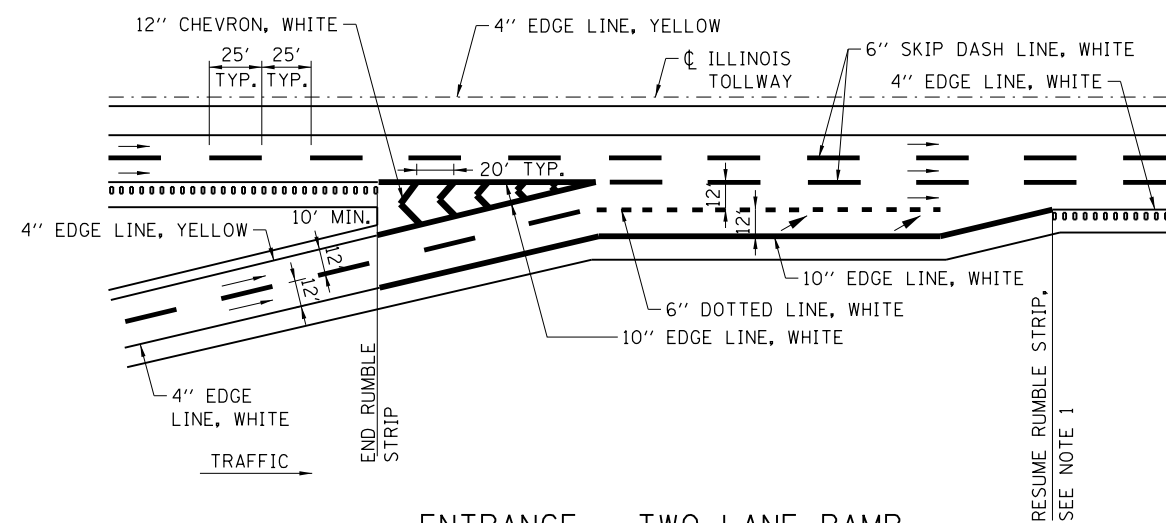

ENTRANCE - TWO LANE RAMP WITH ADDED MAINLINE LANE

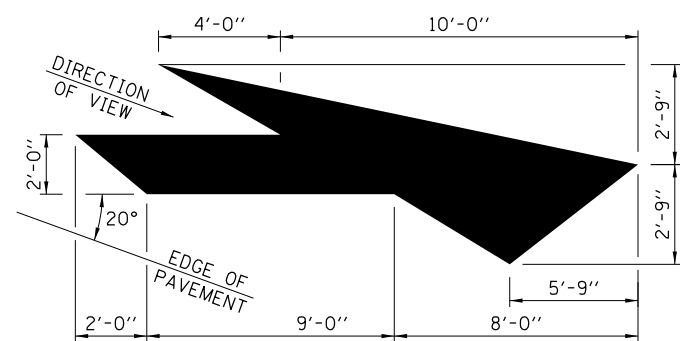

LANE-REDUCTION ARROW

RIGHT LANE-REDUCTION ARROW SHOWN.
USE MIRROR IMAGE FOR LEFT LANE.

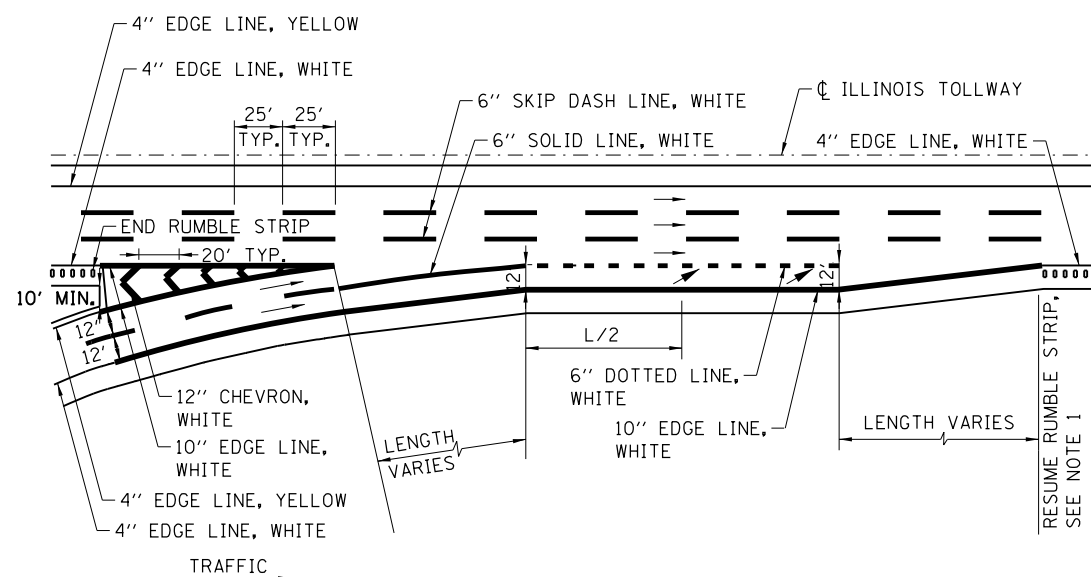

ENTRANCE - TWO LANE RAMP

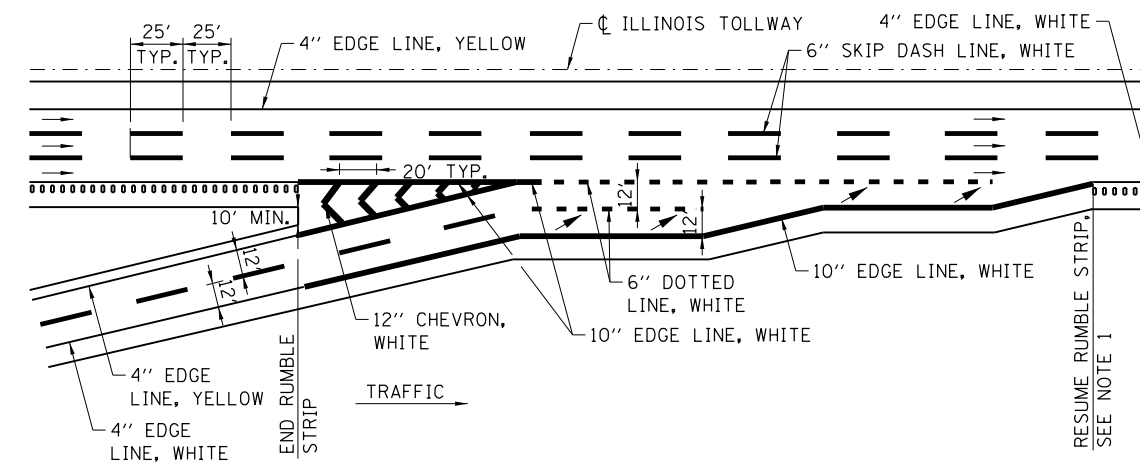

ENTRANCE - TWO LANE PARALLEL RAMP



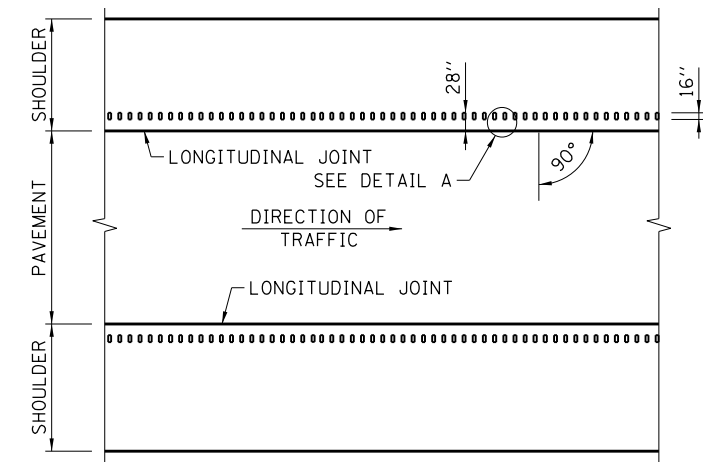
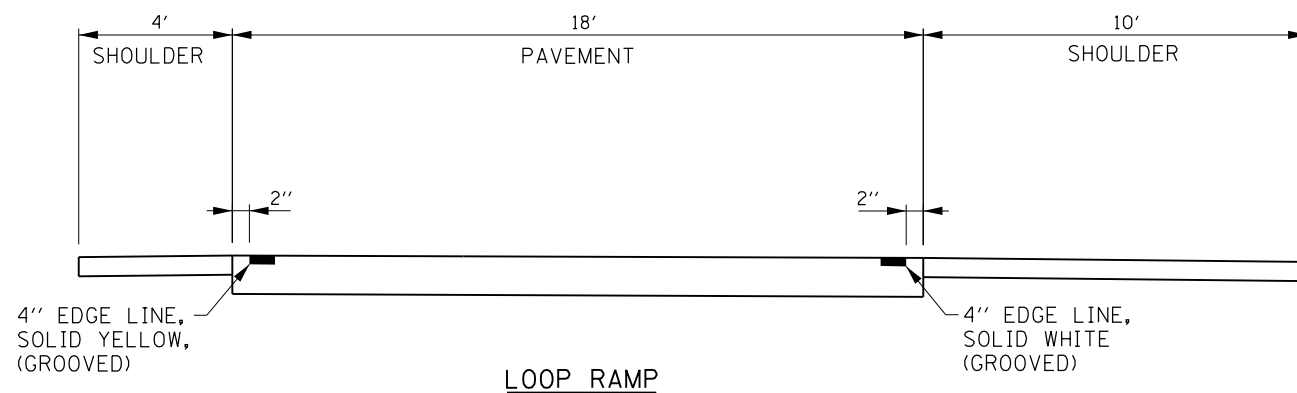
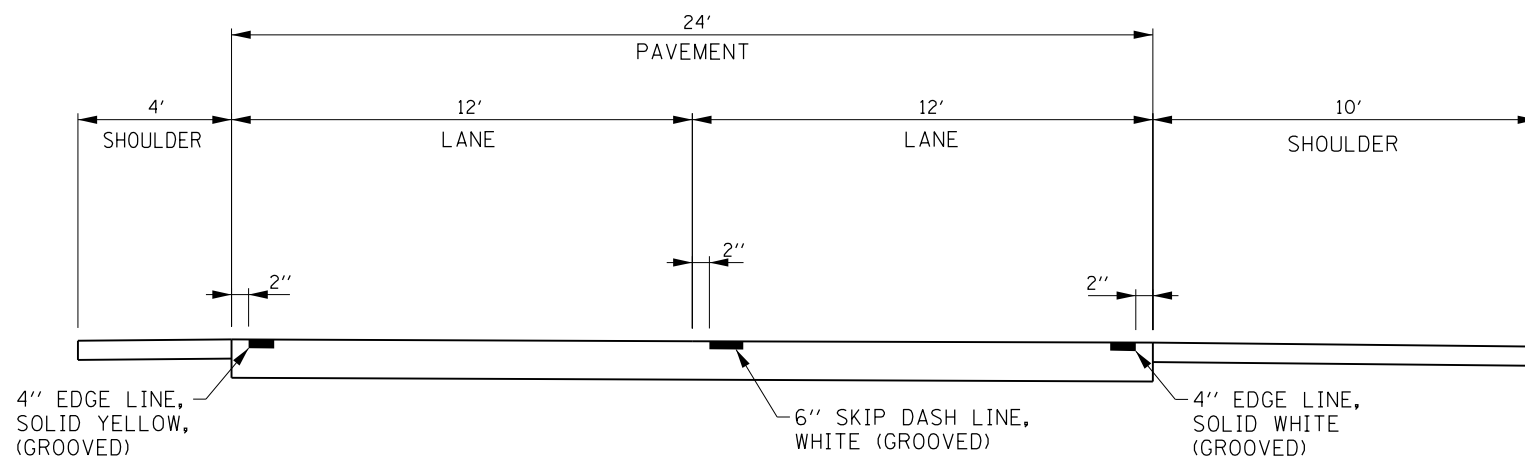
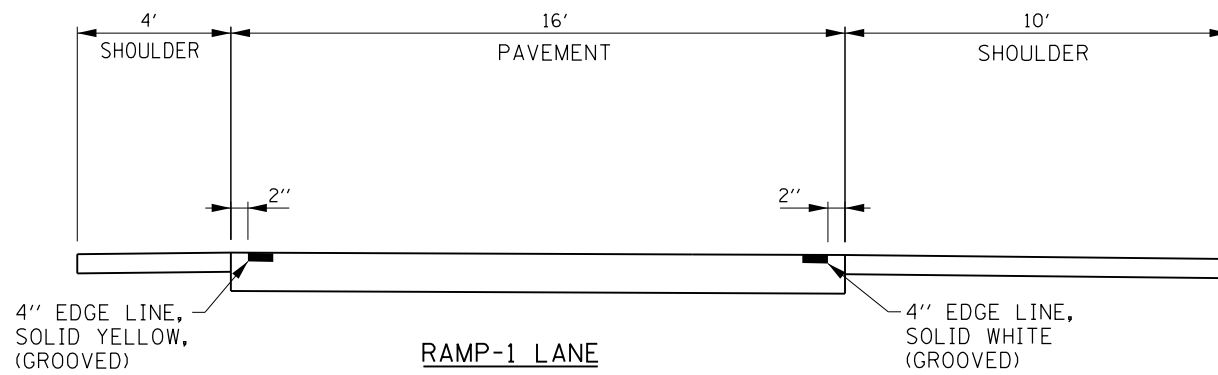

TYPICAL PLAN VIEW
MAINLINE

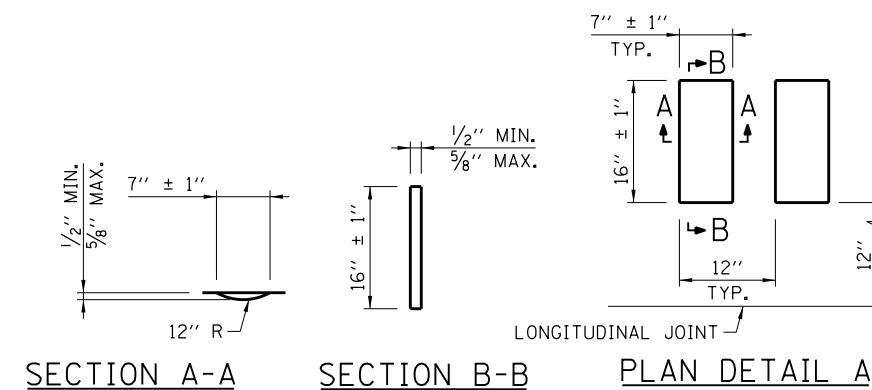

ASPHALT SHOULDER
RUMBLE STRIP DETAILS

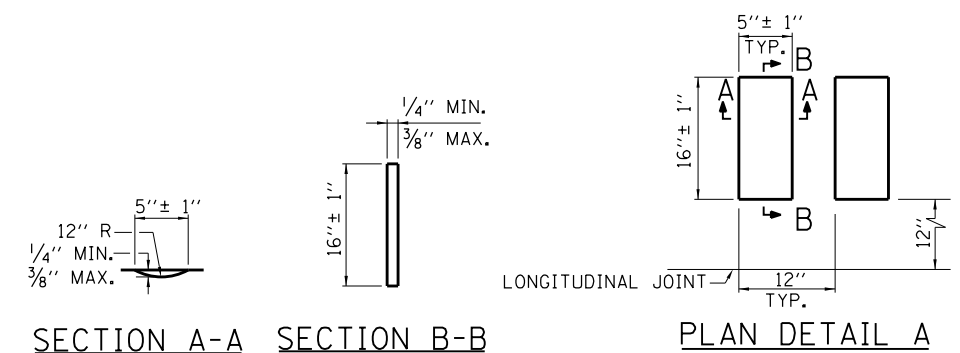

CONCRETE SHOULDER
RUMBLE STRIP DETAILS

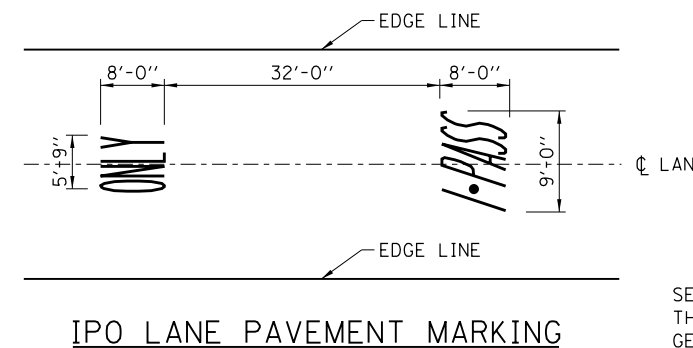

SEE SHEET 1 IN
THIS SERIES FOR
GENERAL NOTES.



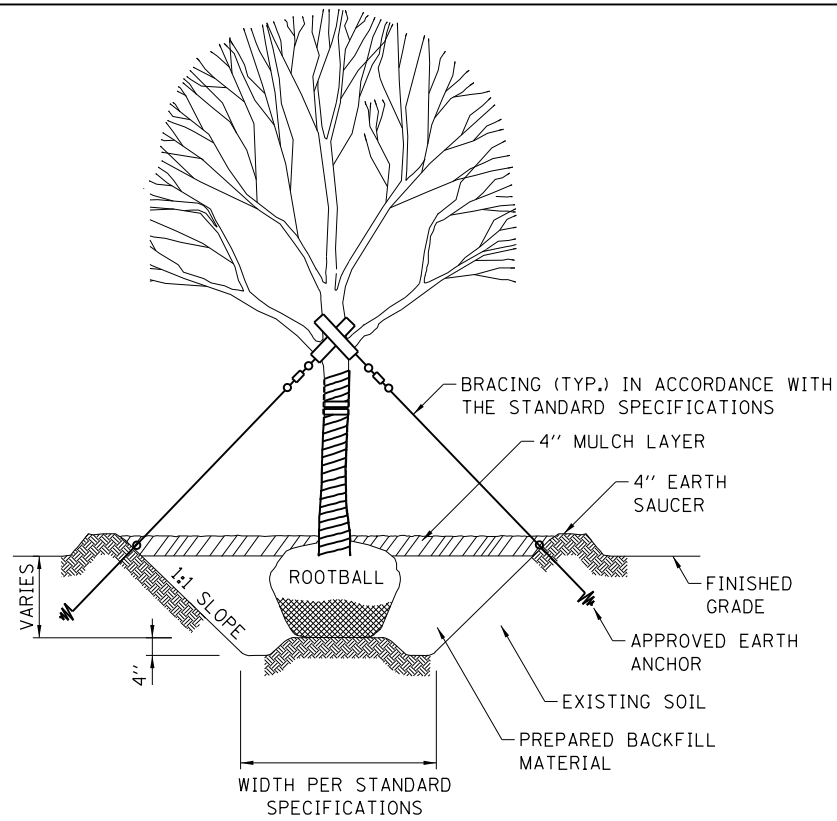

DECIDUOUS TREE PLANTING DETAIL
 (4 1/2" CALIPER AND LARGER)

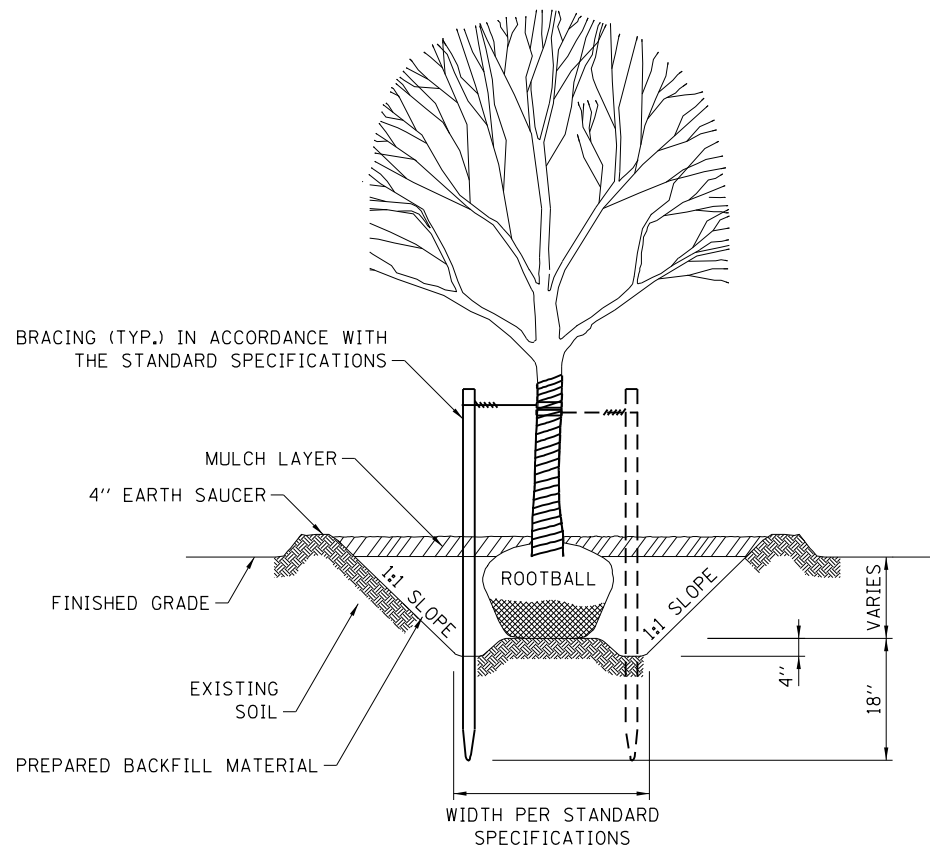

DECIDUOUS TREE PLANTING DETAIL
 GREATER THAN 4 FT HEIGHT AND LESS THAN 4 1/2" CALIPER)

PLANTING NOTES:

1. THE CONTRACTOR SHALL VERIFY THE LOCATIONS OF ALL UNDERGROUND UTILITIES, FIBER OPTICS, STORM SEWERS AND DRAINAGE STRUCTURES IN THE FIELD PRIOR TO THE EXCAVATION OF ANY PLANT PITS OR PLANTING BEDS. LOCATIONS OF TREE AND SHRUB PLANTINGS SHALL BE ADJUSTED TO AVOID DAMAGING ANY UNDERGROUND FEATURES.
2. THE PLANT LOCATIONS SHOWN ON THE PLANS ARE APPROXIMATELY ONLY. THE EXACT LOCATIONS SHALL BE ADJUSTED AS REQUIRED IN THE FIELD BY THE ENGINEER. TREE LOCATIONS SHALL NOT BE MOVED CLOSER TO PAVEMENT EDGES THAN SHOWN ON THE PLANS OR A MINIMUM OF FIFTY (50) FEET.
3. TREES SHALL BE SPACED A MINIMUM OF SIX (6) FEET FROM FENCES.
4. TREE AND SHRUB PLANTINGS SHALL NOT BLOCK ACCESS TO GATES IN FENCES.
5. TREES PLANTED IN TURF AREAS SHALL BE SPACED A MINIMUM OF TEN (10) FEET FROM THE EDGE OF A SHRUB BED.
6. TREES SHALL BE SPACED A MINIMUM OF TEN (10) FEET FROM NOISEWALLS OR OTHER STRUCTURES.
7. DITCHES SHALL BE KEPT CLEAR OF TREE AND SHRUB PLANTINGS. THE MINIMUM VERTICAL DISTANCE BETWEEN DITCH BOTTOMS AND PLANTS SHALL BE THREE (3) FEET.
8. IF DURING EXCAVATION, A PLANT HOLE OR PLANTING BED SHOWS POOR DRAINAGE, STANDING WATER OR AN IMPERVIOUS STRATUM OF SOIL, THE CONTRACTOR SHALL CEASE EXCAVATION AND SHALL NOTIFY THE ENGINEER. THE PLANT(S) SHALL BE RELOCATED AS DIRECTED BY THE ENGINEER AND THE HOLE(S) OR BED SHALL BE FILLED IN AND RESTORED TO MATCH THE CONDITION AND VEGETATION OF THE ADJACENT AREA.
9. IMPROPERLY PRUNED PLANTINGS WILL BE REJECTED AND REPLACEMENTS WILL IMMEDIATELY BE MADE BY THE CONTRACTOR.
10. THE SIDES OF ALL PLANT PITS SHALL BE LOOSENEED TO DISJOIN ANY GLAZING WHICH MAY OCCUR DURING THE DIGGING OPERATION.
11. TREE WRAPPING SHALL EXTEND TO THE LOWEST MAJOR BRANCH.
12. TOP OF ROOTBALL SHALL BE APPROXIMATELY 2 INCHES ABOVE ADJACENT FINISHED GRADE.
13. SHRUB PLANTINGS:
 - A. UNLESS NOTED OTHERWISE, ALL SHRUBS SHALL BE PLANTED IN MULCHED BEDS. THE EDGE OF THE MULCH BED SHALL EXTEND A MINIMUM OF THREE (3) FEET BEYOND THE CENTERS OF THE PERIPHERAL PLANTS IN THE BED.
 - B. THE EDGE OF A MULCH BED FOR SHRUB PLANTINGS ADJACENT TO A WALL, FENCE, GUARDRAIL OR OTHER FIXED OBJECT SHALL EXTEND TO THE OBJECT. THE PERIPHERAL PLANTS IN THE BED SHALL NOT BE PLANTED WITHIN FIVE (5) FEET OF THE OBJECT.
 - C. WHEN A TREE IS LOCATED IN A SHRUB BED, THE MINIMUM DISTANCE BETWEEN THE TREE AND THE ADJACENT SHRUBS SHALL BE SIX (6) FEET.
14. THE CONTRACTOR SHALL RESTORE ALL AREAS, OBJECTS AND VEGETATION DISTURBED BY THE LANDSCAPE OPERATIONS TO ORIGINAL CONDITIONS.
15. STAKES, GUYWIRES AND ALL TREE SUPPORTS SHALL BE REMOVED AFTER ONE YEAR OR AS DIRECTED BY THE ENGINEER.
16. REMOVE ALL TWINE, ROPE, WIRE AND BURLAP FROM TOP HALF OF ROOTBALL. THE LOWER HALF OF BURLAP SHALL BE FOLDED TOWARD THE BOTTOM OF THE ROOTBALL.

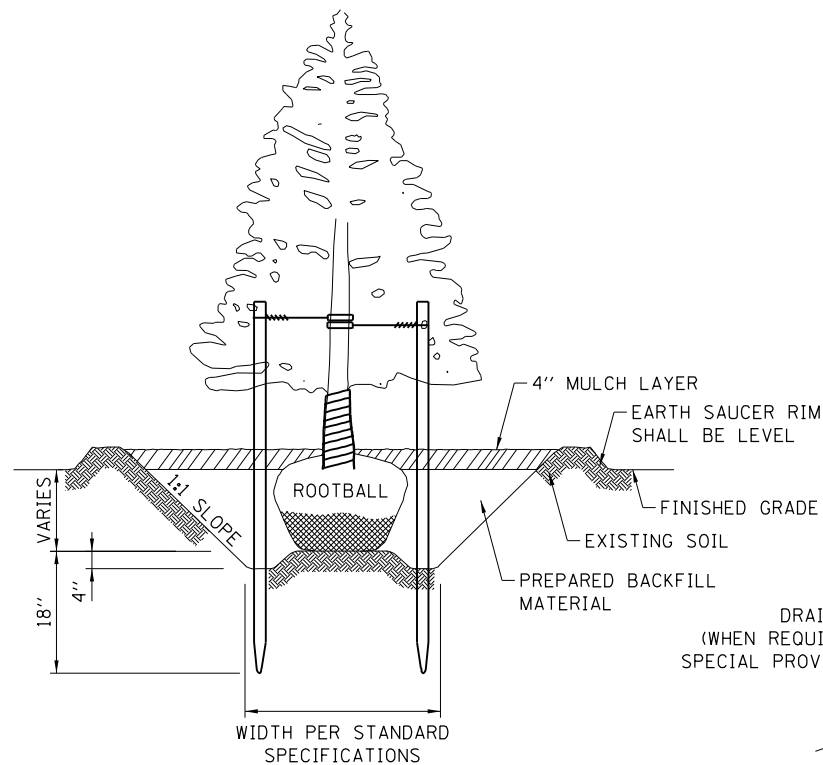

EVERGREEN TREE PLANTING DETAIL

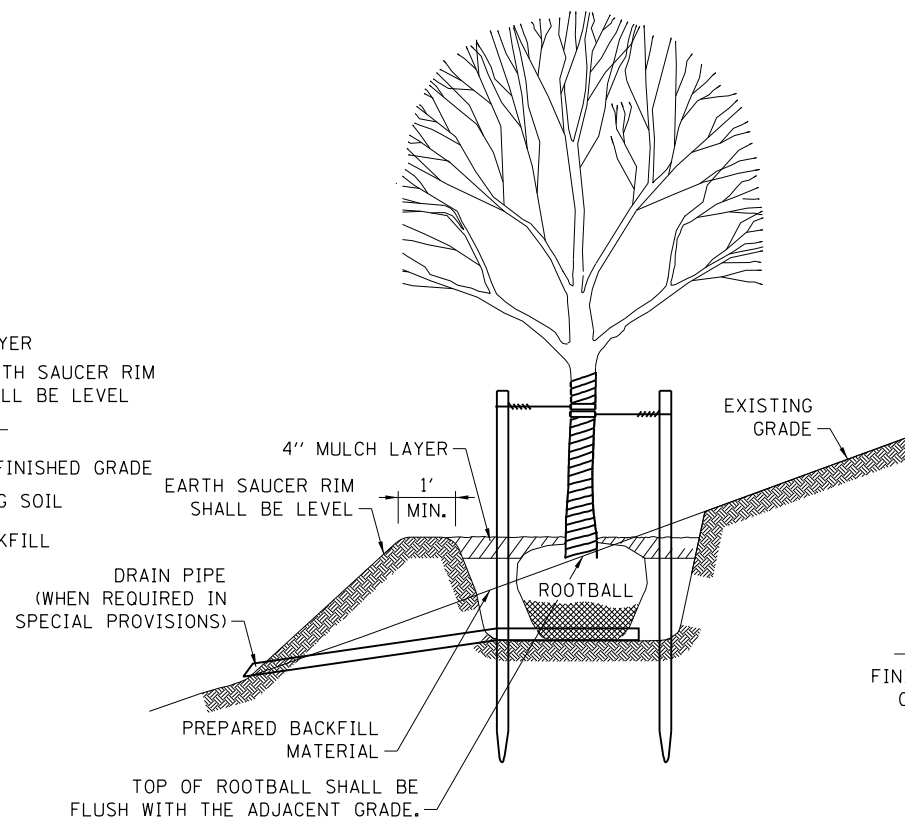

STEEP SLOPE PLANTING DETAIL

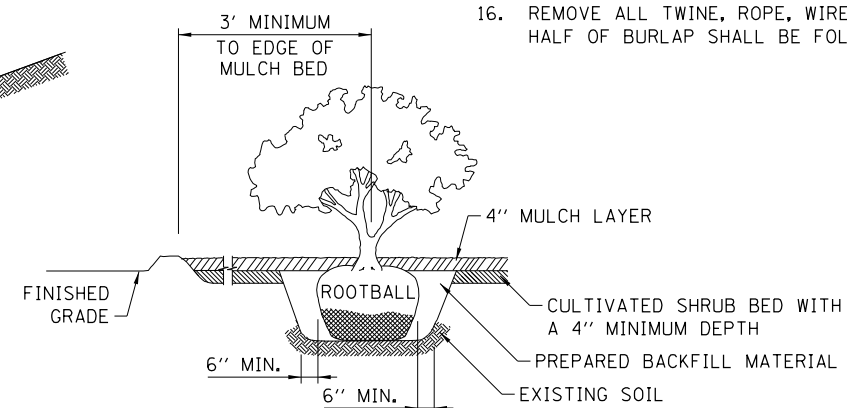

SHRUB PLANTING DETAIL

Paul Kovacs
 APPROVED CHIEF ENGINEER DATE 2-7-2012

DATE	REVISIONS
02-07-12	REVISED POST BRACING DETAIL
03-31-16	REVISED MULCH LAYER THICKNESS AND PLANTING NOTES

Illinois Tollway

LANDSCAPE PLANTING
 DETAILS

STANDARD D7-02

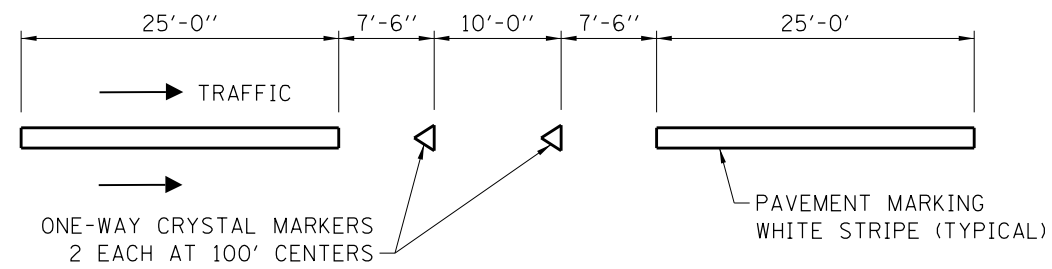

DETAIL A

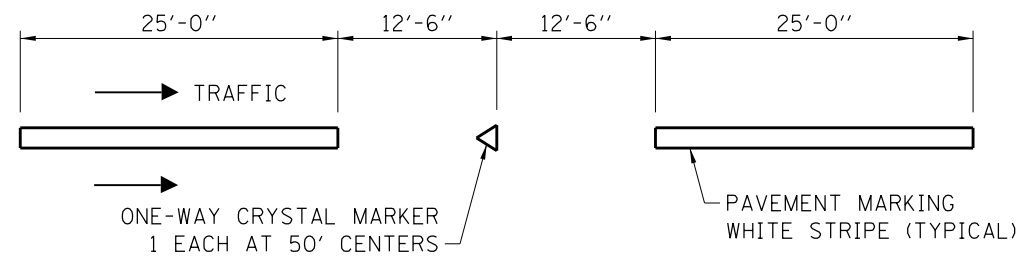

DETAIL B

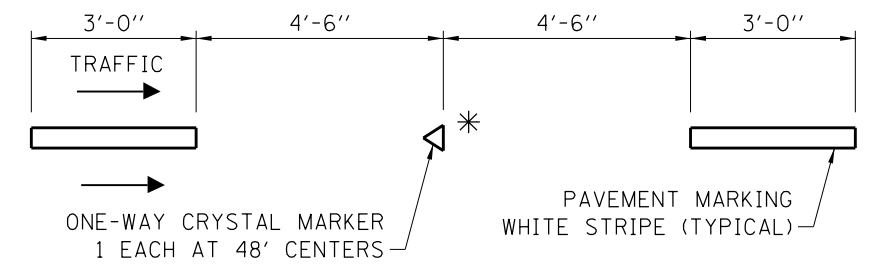

* MARKER TO BE INSTALLED WHEN LENGTHS OF AUXILIARY LANES ARE GREATER THAN 1000'.

DETAIL C

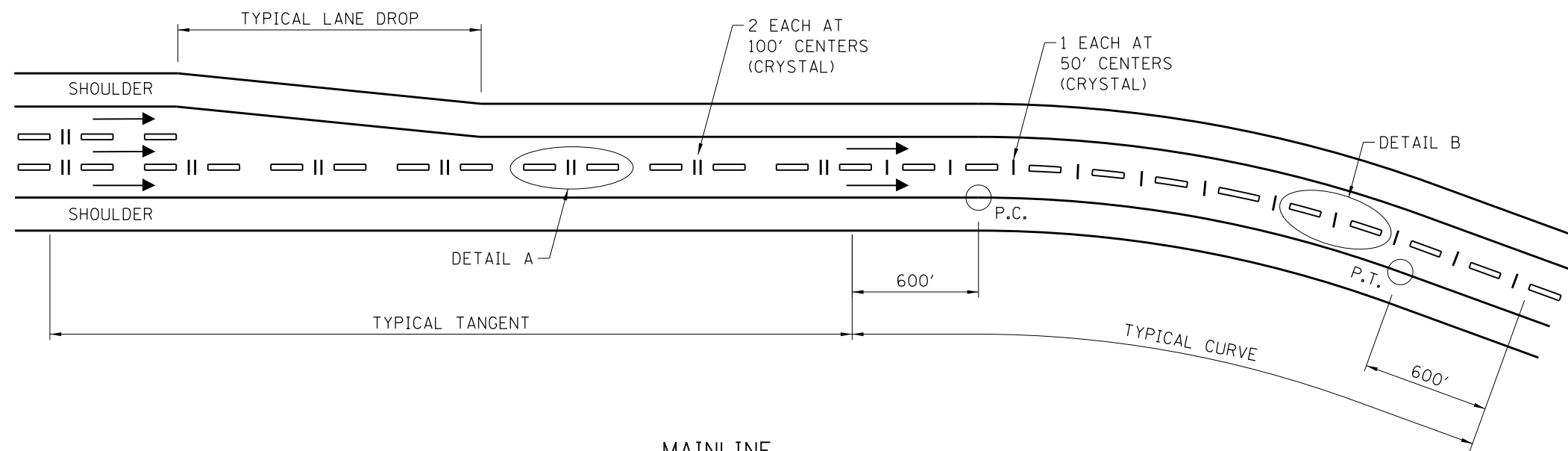

MAINLINE

RAISED PAVEMENT LANE MARKER DETAILS

NOTES:

1. FOR COLLECTOR-DISTRIBUTOR (C-D) ROADWAYS, PLACE ONE-WAY CRYSTAL MARKER, 2 EACH AT 100' CENTERS. USE DETAIL A.
2. FOR MULTI LANE DIRECTIONAL RAMPS, PLACE ONE-WAY CRYSTAL MARKER, 1 EACH AT 50' CENTERS. USE DETAIL B.
3. FOR AUXILIARY LANES, PLACE ONE-WAY CRYSTAL MARKER, 1 EACH AT 48' CENTERS. USE DETAIL C.

APPROVED *Paul Kovacs* CHIEF ENGINEER DATE 7-1-2009

DATE	REVISIONS
11-01-2012	REVISED DETAIL C.
3-31-2016	REVISED NOTES 1.



RAISED PAVEMENT LANE MARKER

STANDARD D8-02