

March 2023

Quality Standard for Work Zone Traffic Control Devices

ILLINOIS STATE TOLL HIGHWAY AUTHORITY





INTRODUCTION

Quality Standard for Work Zone Traffic Control Devices

The Quality Standard for Work Zone Traffic Control Devices Manual provides guidance on the Illinois Tollway standards for inspecting work zone traffic control devices. This quality standard is intended to provide a detailed listing of criteria, guidelines, policies and procedures to be followed by an inspector to determine the quality of work zone traffic control devices during several stages of their use, including while

in storage, during preparation for delivery to the work zone, during initial set-up and periodically during the course of the work. This standard shall also apply to suppliers and contractors prior to the delivery of work zone traffic control devices to the jobsite.

The Quality Standard for Work Zone Traffic Control Devices, dated March 2023, replaces the version Issued March 2022.

Major Highlight Revisions

Section 7.0: Quality Standard for Temporary Concrete Barrier	
Article 7.0	Changed reference from IDOT Standard to the MOT manual
Appendix B: Traffic Control Inspection Report	
Appendix B	Revised directory in the WBPM system where Traffic Control Inspection Report.

TABLE OF CONTENTS

SECTION 1.0	INTRODUCTION	1
1.1	Application of this Standard	1
1.2	Quality Classifications and Requirements	1
SECTION 2.0	QUALITY STANDARD FOR SIGNS	3
SECTION 3.0	QUALITY STANDARD FOR BARRICADES AND VERTICAL PANELS	5
SECTION 4.0	QUALITY STANDARD FOR DRUMS	8
SECTION 5.0	QUALITY STANDARD FOR CONES	10
SECTION 6.0	QUALITY STANDARD FOR SLOW PADDLE	12
SECTION 7.0	QUALITY STANDARD FOR TEMPORARY CONCRETE BARRIER	14
SECTION 8.0	QUALITY GUIDELINES FOR MISCELLANEOUS WORK ZONE TRAFFIC CONTROL DEVICES	20
8.1	Quality Guideline for Impact Attenuators, Temporary	20
8.2	Quality Guidelines for Warning Lights	20
8.3	Quality Guideline for Arrow Boards	21
8.4	Quality Guideline for Portable Changeable Message Signs (PCMS)	22
8.5	Quality Guideline for Work Zone Pavement Marking	23
8.6	Quality Guideline for Glare Screens on Barrier Wall	24

APPENDICES

APPENDIX A Construction Work Zone Array

APPENDIX B Traffic Control Inspection Report

SECTION 1.0 INTRODUCTION

Traffic controls are a necessary part of highway work zones to warn motorists of hazards, advise them of the proper path through the work zone, delineate areas where they may not operate, and to separate them from the workers. This is accomplished by the deployment of a system of devices. The success of this system depends on the quality of each device and its placement. Requiring all devices to be new at the time of a project's initial installation can easily control quality. This, however, would not be in the best interest of controlling costs and reducing waste. This standard does not apply to new devices but should aid in the determination of the quality of used devices.

The normal temporary use of work zone traffic control devices subjects them to wear that do not occur to permanent devices. Much of this wear may be due to carelessness during the storage, shipping, relocating, removal of these devices, impacts from traffic or equipment, or simply age. This wear causes much of the deterioration of their appearance. Whenever a high percentage of these worn and damaged devices appear on the same project, the general appearance of the work zone leaves undesirable results and could lead to a potential loss of motorist confidence and compliance.

This standard has been developed to aid the inspector in determining the quality of the work zone devices. A determination of quality should be made at several stages: while in storage, during preparation for delivery to the work zone, during initial set-up and periodically during the course of the work. Suppliers and contractors are to apply this standard prior to delivery of devices to the jobsite. Doing so will minimize labor and inspection involvement and reduce time, effort, and costs related to on-site replacement.

All devices and combinations of devices shall meet the requirements of the National Cooperative Highway Research Program (NCHRP) Report 350 or the AASHTO Manual for Assessing Safety Hardware (MASH) for their respective categories, in accordance with the IDOT Standard Specifications, Tollway Supplemental Specifications and/or Special Provisions of the governing contract.

1.1 Application of this Standard

Any traffic control device, which has become ineffective due to damage or defacement, shall be replaced by the Contractor according to the contract provisions. All traffic control devices **shall be maintained** and kept clean such that the device maintains its appearance and retro reflectivity. The Engineer shall be the sole judge as to the acceptability of placement and maintenance of all traffic control devices.

The Resident Engineer will review the condition of all Maintenance of Traffic (MOT) signs prepared for the project and approve the quality before deployment.

1.2 Quality Classifications and Requirements

The quality of the work zone devices in this standard has been divided into three categories, **acceptable**, **marginal**, and **unacceptable**.

At the time of the initial set-up, major stage changes, and when becoming the property of the

Tollway, 100% of each type of device shall be acceptable. Throughout the duration of the project, the percentage of acceptable devices may decrease to 75% (25% marginal) only as a result of damage and/or deterioration during the course of the work. Any unacceptable device shall be replaced as soon as it becomes unacceptable.

Acceptable: Devices that meet the quality requirements herein for this classification and all other requirements in the plans and specifications shall be determined to be **acceptable** for use on highway construction or contract maintenance projects.

Marginal: Devices that meet the quality criteria for **marginal** as described herein may remain in the work zone until they reach 25% for that type of device or until it is determined that they have become **unacceptable**.

Unacceptable: Devices in this category shall not be delivered to the jobsite. When found in the work zone, they shall be immediately removed and replaced.

The photographs included herein, together with the contract requirements of each specific project, shall be used as a guide to determine if the device is **acceptable, marginal** or **unacceptable**. A direct comparison of each device to this standard is not required for the rejection of devices; however, this standard shall be used to resolve disputes. One aid in avoiding potential disputes is to retain samples of new, unused devices in each category to supplement the photographs shown in the following pages or manufacturer's specifications.

SECTION 2.0 QUALITY STANDARD FOR SIGNS

This standard applies to all signs; warning, regulatory, informational, and guide furnished by a supplier, subcontractor, or contractor to be used for traffic control work zones.

All standard signs shall conform to the requirements of the contract documents and the Manual on Uniform Traffic Control Devices and its supporting manuals, and Tollway guidelines. In complying with these requirements, the contractor and suppliers shall furnish signs that are correct in size, shape, color and legend. Special signs, should they be required, are detailed in the plans. Work zone signs shall meet the requirements of Article 1106.01 of the Standard Specifications for retro reflectivity and Article 701.03(d) of the Tollway Supplemental Specifications.

For signs to be used in work zones, all of the above requirements must be met to the satisfaction of the Engineer. In addition, requirements of Section 701 of the Tollway Supplemental Specifications regarding sign erection and installation shall be met. Sign positioning at the work site may be minimally adjusted with Engineer approval based on site conditions.

The Evaluation Guide provided in this section shall be used to evaluate the quality of the sign face only. No mention is made of dents, bends or other deformations. If any sign is bent to the extent that its shape is nonstandard or a portion of the sign itself is missing, the sign shall be determined unacceptable.

TYPICAL SIGN INSTALLATION

See Standard 701901 Specified in Contract for Specific Requirements

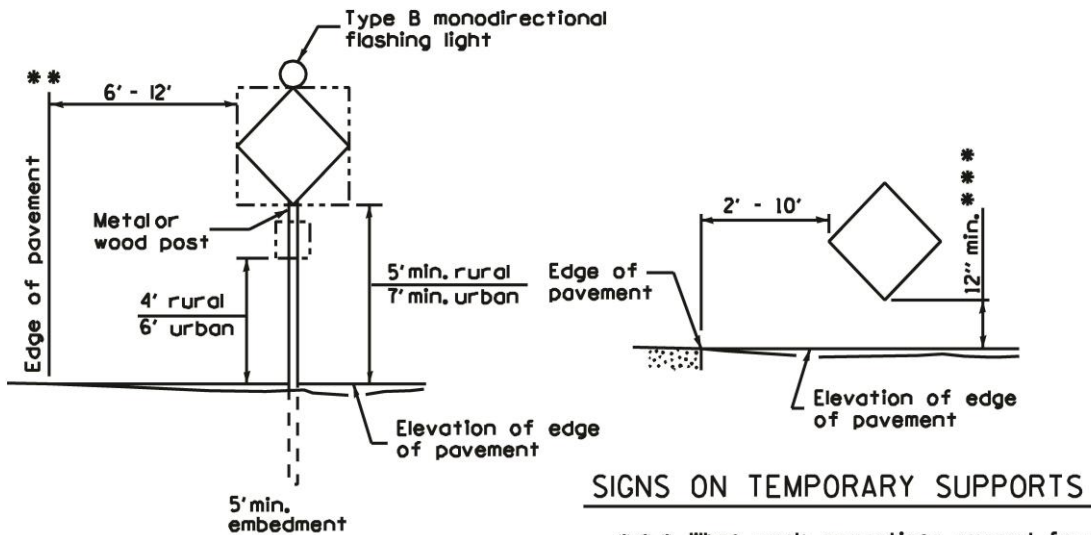

POST MOUNTED SIGNS
 ** When paved shoulder are present this dimension shall be 6' to the outside edge of the paved shoulder.

*** When work operations exceed four days, this dimension shall be 5' min. If located behind other devices, the height shall be sufficient to be seen by motorists.

All heights shall be measured above the pavement surface.

EVALUATION GUIDE – SIGNS

Acceptable: This is an example of an **acceptable** sign. It is not new. There are abrasions on the surface but very little loss of lettering. There has been no touch-up of the lettering.



Marginal: This is an example of a sign with **marginal** acceptability. Of the many surface abrasions throughout the sign face, many are within the individual letters of the message. The sign surface is free of any residue. Although some color fading is evident, the background color and reflectivity are still apparent at night.



Unacceptable: This is an example of an **unacceptable** sign. Signs with asphalt splatter and/or cement slurry or any combination of missing and/or covered reflective material similar in area presented would also make a sign **unacceptable**. Some letters have a loss of more than 50 percent. There is noticeable color fading.



Please Note: Orange work zone signs shall be fluorescent orange in color. Signs shall have retroreflective sheeting. Signs with bends and dents that alter the size and/or shape of the sign are unacceptable. These photos are to be used as examples of the condition of the sheeting only.

SECTION 3.0 QUALITY STANDARD FOR BARRICADES AND VERTICAL PANELS

This standard applies to Type I, II and III barricades, vertical barricades, directional indicator barricades and panels furnished by a supplier, subcontractor, or contractor for traffic control use in work zones.

Barricade type and placement of barricades and vertical panels are specified in the contract documents. Barricades and vertical panels used in the work zones shall meet the retro reflectivity requirements specified in Article 1106.02 (c and d) of the Standard Specifications, and Article 701.03 (a) of the Tollway Supplemental Specifications. The Tollway contract may have additional requirements in the Special Provisions.

For barricades and vertical panels to be used in work zones, all of the above requirements shall be met to the satisfaction of the Engineer. In addition, the requirements of IDOT Highway Standard 701901 regarding size, shape, and mounting height shall be met. Vertical panels shall be erected and maintained in a vertical position.

The Evaluation guide provided in this section shall be used to evaluate the quality of the retro reflectorized portion of barricades and vertical panels. In addition to this evaluation, device supports must also be evaluated.

Any one or combination of the following will cause the device to be unacceptable:

- Deformation of the support assembly so the sheeted panel is not oriented correctly.
- Device is bent or legs are twisted.
- Rusty metal parts.
- Unpainted wooden rails.
- Broken panels.
- Does not meet NCHRP 350 or MASH requirements.

TYPICAL DRAWINGS OF TYPE I, II, AND III BARRICADES, DIRECTIONAL BARRICADES AND VERTICAL PANELS

See Standard 701901 specified in Contract for Specific Requirements

All dimensions are in inches unless otherwise shown.

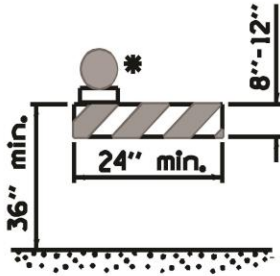

TYPE I BARRICADE

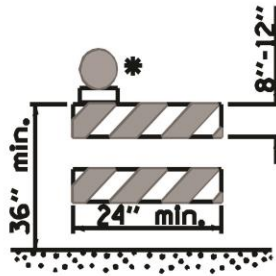

TYPE II BARRICADE

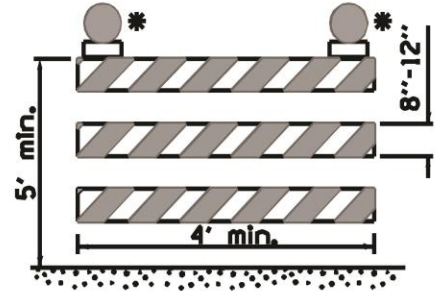

TYPE III BARRICADE

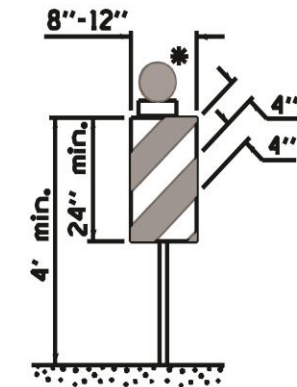

**VERTICAL PANEL
POST MOUNTED**

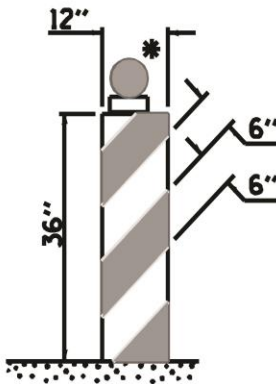

VERTICAL BARRICADE

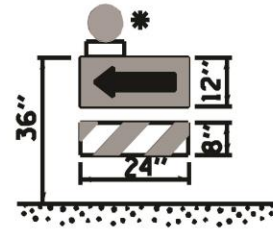

**DIRECTION INDICATOR
BARRICADE**

* Warning lights (if required)

Please Note: The arrow panel in directional barricades shall conform to the Quality Standard for Signs.

EVALUATION GUIDE - BARRICADES

Acceptable: This is an example of an **acceptable** panel. It is not new. There are several abrasions on the surface but very little loss of retroreflective sheeting. The orange is vivid, and the stripes provide contrast that is clearly visible with low beam headlights at night.



Marginal: This is an example of a panel with **marginal** acceptability. There are numerous surface abrasions throughout the panel surface. Some color fading is evident. However, it is free of large areas of residue or missing reflective material. The colors, stripes, and reflectivity are visible and discernible with low beam headlights at night.



Unacceptable: This is an example of an **unacceptable** panel. The surface is marred over a high percentage of the panel area. There is noticeable loss of reflectivity and obvious color fading. Panels with asphalt splatter and/or cement slurry, or any combination of missing and/or covered reflective material similar in area presented would make a panel **unacceptable**.



SECTION 4.0 QUALITY STANDARD FOR DRUMS

This standard applies to drums that are furnished by a supplier, subcontractor, or contractor for traffic control in work zones.

Drum placement is specified in the contract documents. Drums used in work zones shall meet the requirements of Article 701.03(c) of the Tollway Supplemental Specifications and Article 1106.02 (e) of the Standard Specifications, and have alternating Type AA, AP, or ZZ fluorescent orange and white, circumferential stripes.

The Evaluation Guide provided in this section shall be used to evaluate the general appearance of drums. In addition, drums that are dented severely enough to affect the overall dimension and shape or contain fractures that affect their stability or ability to retain the retroreflective sheeting are unacceptable.

TYPICAL DRAWINGS OF DRUMS

See Standard 701901 Specified in Contract for Specific Requirements

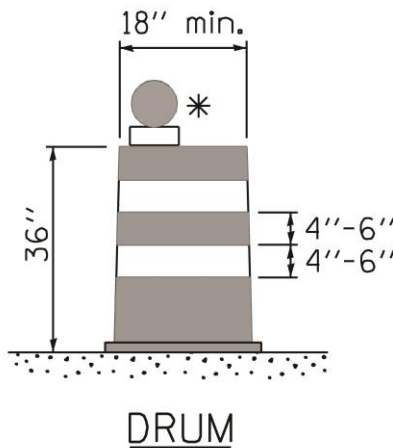

* Warning lights (if required)

EVALUATION GUIDE – DRUMS

Acceptable: This is an example of an **acceptable** drum. It is not new. The sheeting has only minor tears and scratches. It will readily respond to washing.



Marginal: This is an example of a drum with **marginal** acceptability. The sheeting has numerous tears and scratches; however, it is free of large areas of residue or missing reflective material. Some fading is evident. It may not readily respond to washing.



Unacceptable: This is an example of an **unacceptable** drum. The large areas of missing reflective material make this drum **unacceptable**. Drums with asphalt splatter and/or cement slurry, or any combination of missing and/or covered reflective material similar in area presented would also make a drum **unacceptable**. Large areas of fading are evident. It will not respond to washing.



Note: Alternating white and fluorescent orange retroreflective sheeting is required on drums. All non-reflectORIZED portions of the drums shall be orange.

SECTION 5.0 QUALITY STANDARD FOR CONES

This standard applies to cones that are furnished by a supplier, subcontractor, or contractor for traffic control in work zones.

Cones shall only be used when specified in the contract documents. Cones used in work zones shall meet the requirements of Article 1106.02 (b), of the Standard Specifications, IDOT Highway Standard 701901, and Article 701.03(b) of the Tollway Supplemental Specifications.

The Evaluation Guide provided in this section shall be used to evaluate the general appearance of cones.

In addition, cones that contain fractures that affect their stability or their ability to maintain their placement are unacceptable.

TYPICAL DRAWINGS OF CONES

See Standard 701901 Specified in Contract for Specific Requirements

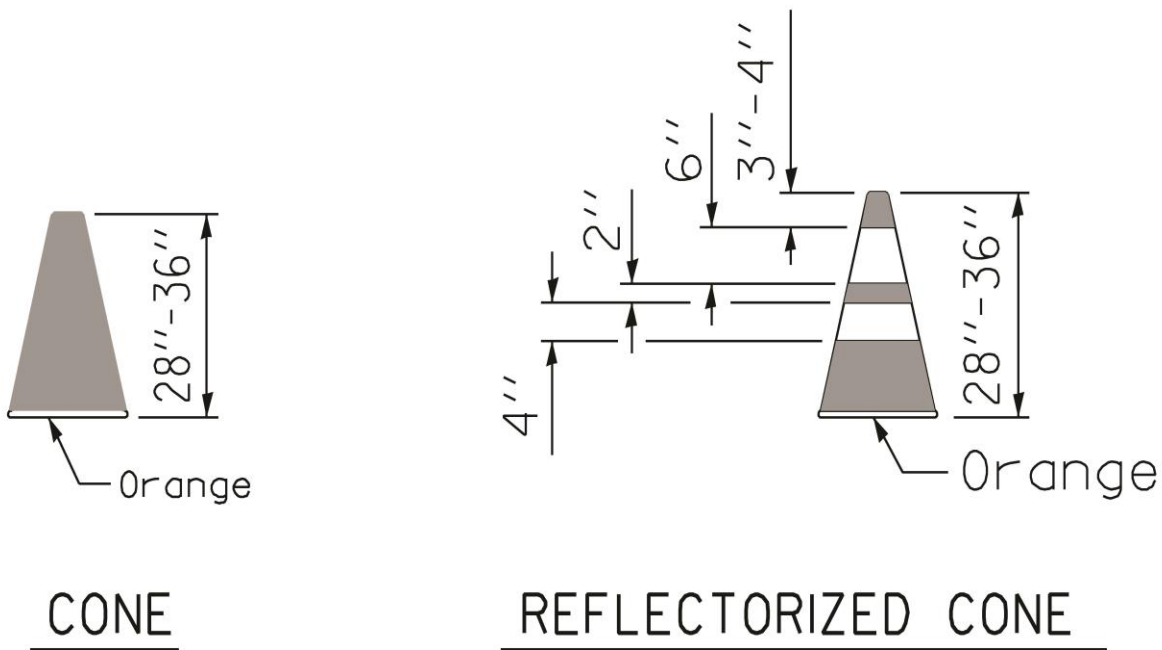

EVALUATION GUIDE - CONES

Acceptable: These are examples of **acceptable** cones. Although they are not new the surfaces are free of punctures and abrasions, and the color is bright. The surfaces may be dirty but will readily respond to washing.



Marginal: These are examples of cones with **marginal** acceptability. The surfaces are dirty and may not be readily cleaned due to abrasion and discoloration.



Unacceptable: This is an example of **unacceptable** cones. Punctures and large areas of staining make these an unlikely candidate for improvement. Also, large areas of asphalt splatter and/or cement slurry would make cones **unacceptable**.



SECTION 6.0 QUALITY STANDARD FOR SLOW PADDLE

This standard applies to flagging equipment furnished by a supplier, subcontractor, or contractor for traffic control in work zones and is covered in Article 701.03(i) of the Tollway Supplemental Specifications.

Paddles used in work zones shall meet the requirements of Article 1106.01 of the Standard Specifications and IDOT Highway Standard 701901. In complying with these requirements, the contractor and suppliers will furnish signs that are correct in size, shape, color and legend. The SLOW face shall consist of black letters and border on a fluorescent orange retro reflectorized background.

The Evaluation Guide provided in this section shall be used to evaluate the general appearance of stop/slow paddle.

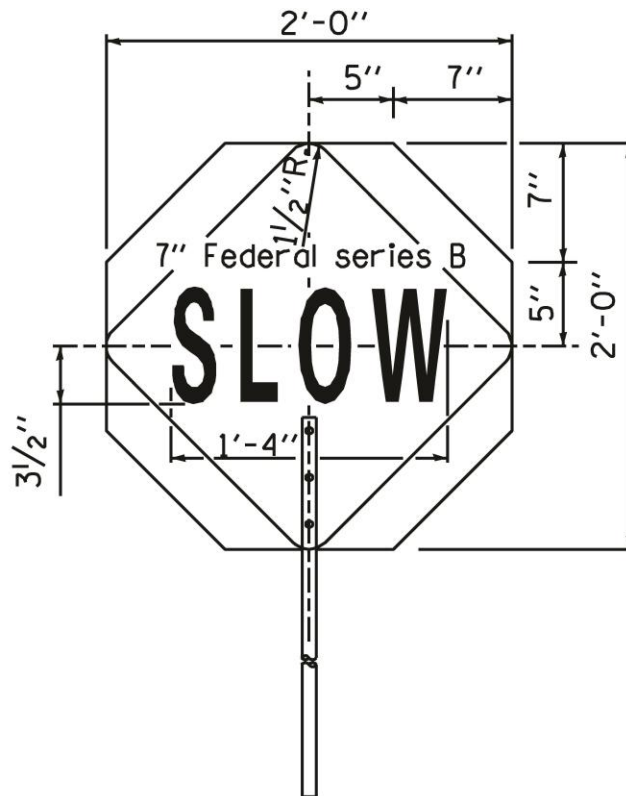

EVALUATION GUIDE-PADDLE

Acceptable: This is an example of an **acceptable** paddle. It is not new. There are several abrasions on the surface but very little loss of lettering. There has been no touch-up of the lettering. The sheeting color is vivid with contrasting colors. The handle color is the same as the sheeting color. The paddle is 6' high from pavement to bottom of sign. The surface may be dirty but will readily respond to washing.



Marginal: This is an example of a paddle with marginal acceptability. Of the many surface abrasions throughout the paddle face, many are within the individual letters of the message. The paddle surface is free of any residue. Although some color fading is evident, the background color and reflectivity are still apparent at night. The surface is dirty and may not be readily cleaned due to abrasion and discoloration.



Unacceptable: This is an example of an **unacceptable** paddle. Paddles with asphalt splatter and/or cement slurry of an amount similar to the abrasions that are evident throughout the face of this sign are unacceptable. Some letters have a loss of more than 20 percent. Color fading is noticeable.



SECTION 7.0 QUALITY STANDARD FOR TEMPORARY CONCRETE BARRIER

This standard applies to temporary concrete barrier furnished by a supplier, subcontractor, or contractor for traffic control in work zones. The Temporary Concrete Barrier shall comply with the Illinois Tollway special provision and have the F-shape. Temporary Concrete Barrier shall conform to either IDOT Highway Standard 704001 (for NCHRP Report 350 applications) or the Illinois Tollway Standard “Temporary Concrete Barrier with Cross-Bolt Connection” (for MASH Test Level 3 applications) as shown in the plans and contract documents.

The barrier unit at each end of the installation shall be secured to the pavement or paved shoulder as described in the MOT Manual, Article 6.4.7 and protected with an accepted NCHRP Report 350 or MASH Test Level 3 crashworthy device as shown on the plans.

Connecting pins and anchor pins shall be according to Standard 704001.

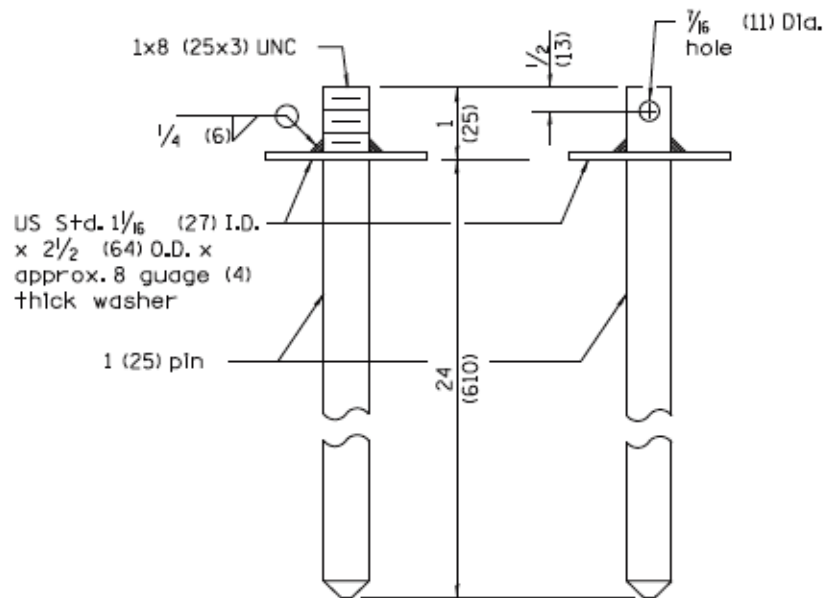

CONNECTING AND ANCHOR PINS

(End may be beveled $\frac{1}{4}$ (6) max.)

The Evaluation Guide provided in this section shall be used to evaluate the general appearance of temporary concrete barrier. The CM and Contractors QC shall verify that temporary concrete barriers are in compliance with these guidelines. Images and drawings refer to IDOT Standard Barrier and may be used as a guide for evaluating both standard and cross-bolted barrier.

EVALUATION GUIDE - TEMPORARY CONCRETE BARRIER

Acceptable: These are examples of acceptable temporary barrier wall. The walls appear new with few minor blemishes. Wall repaired according to Tollway Recurring Special Provision, TEMPORARY CONCRETE BARRIER is acceptable. The connecting loop bars or connecting cross-bolts are in place and in good condition.

Concrete spalling, chipping and delamination not greater than 1.5 inches in depth and 4.0 inches in length measured horizontally, vertically, or diagonally will not require patching as long as the exposed cavity has side slopes of at least 1:3 (V:H).

Cracks are tightly compressed, exhibiting no displacement and do not compromise the structural integrity of the wall.

Most importantly, the wall is structurally sound and none of the spalling or chipping compromises the overall safety shape profile of the barrier or causes a potential snag point on the barrier system during an impact.



EVALUATION GUIDE- TEMPORARY CONCRETE BARRIER

Marginal: These are examples of temporary barrier wall which are marginal. The walls have minor spalls with hairline cracks and minor imperfections along the base but are still structurally sound. The connecting loops are all in place and in good condition.

Concrete spalling, chipping and delamination greater than 1.5 inches and up to and including a depth of 2.5 inches shall be repaired according to Tollway Recurring Special Provision, TEMPORARY CONCRETE BARRIER.

Concrete spalling, chipping and delamination greater than 2.5 inches in depth shall be repaired by methods proposed by the Contractor and approved by the Engineer.

Cracks are tightly compressed, exhibiting no displacement and do not compromise the structural integrity of the wall.

Most importantly, the wall is structurally sound and none of the spalling or chipping compromises the overall safety shape profile of the barrier or causes a potential snag point on the barrier system during an impact.



EVALUATION GUIDE - TEMPORARY CONCRETE BARRIER

Unacceptable: These are examples of unacceptable temporary concrete barrier walls. The barrier walls have large spalls and cracks, with unsound concrete that could be easily removed when hit, and the connecting loop bars may be broken or damaged.

Concrete spalling, chipping and delamination greater than 2.5 inches in depth with any cracks exhibiting displacement or multiple defects which combine to make the barrier structurally unsound per engineering judgment, is cause for rejection.

Barriers that have open cracks with the cracks extending completely through the barrier shall not be accepted. Barrier with cracks that extend from the edge of the wall base to the pinholes shall not be accepted.

A wall is deemed unacceptable if the overall safety shape profile of the barrier is compromised, there may be a potential snag point on the barrier system during an impact, or the wall is not structurally sound.

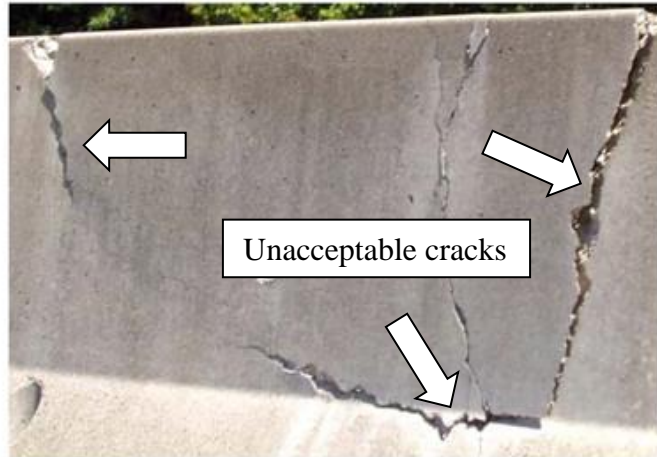

TYPICAL SAFETY SHAPE DEFECTS (NOT ALL INCLUSIVE)

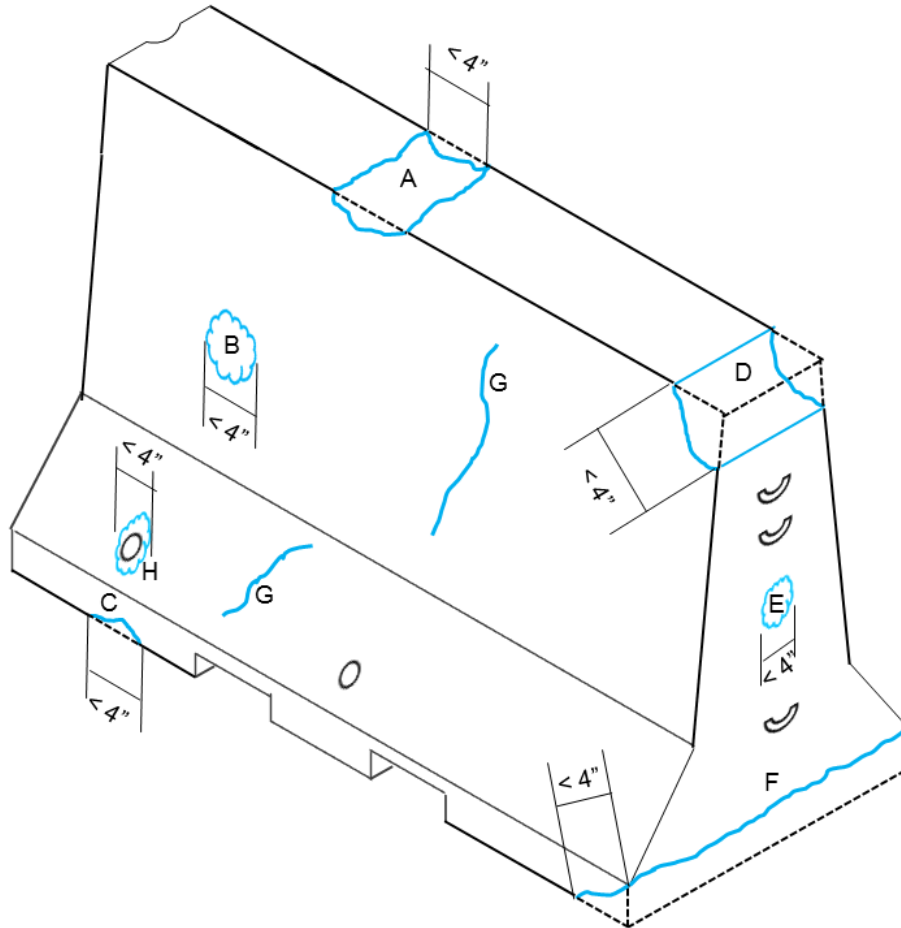

Above is a diagram of a temporary concrete barrier with some typical defects that may be acceptable. Below are the descriptions of defects that may be deemed acceptable.

- A. Spall on top of barrier, less than 4" measured horizontally, vertically, or diagonally and less than 1.5" depth.
- B. Spall on surface of barrier, less than 4" measured horizontally, vertically, or diagonally and less than 1.5" depth.
- C. Spall on bottom of barrier, less than 4" measured horizontally, vertically, or diagonally. Does not create a snag point or compromise the safety shape.
- D. Spall on top corner of barrier, less than 4" measured horizontally, vertically, or diagonally. Does not create a snag point or compromise the safety shape.
- E. Spall on end face of barrier, less than 4" measured horizontally, vertically, or diagonally and 1.5" depth. Does not interfere with connecting loop bars or cross-bolts.
- F. Spall on bottom corner of barrier, less than 4" measured horizontally, vertically, or diagonally. Does not create a snag point or compromise the safety shape.
- G. Crack tightly compressed, exhibiting no surface displacement and not combined with other defects.
- H. Spall around pin hole, less than 4" measured horizontally, vertically, or diagonally.

It is important to note that the barrier may still be deemed unacceptable if the CM determines that it is not structurally sound or if damage interferes with the functionality of the connecting system (pins/loops or cross-bolts).

NOTE: Temporary Concrete Barrier must be in accordance with standards. This drawing is a sketch (not to scale) intended to discuss defects, not the shape of the wall.

SECTION 8.0 QUALITY GUIDELINES FOR MISCELLANEOUS WORK ZONE TRAFFIC CONTROL DEVICES

The following guidelines are for several other work zone traffic control devices. Whereas the Quality Standards address individual devices, the guidelines address complete groups of work-site traffic control devices. When a certain percentage of devices as a group become non-conforming, that portion of the traffic control installation will become **unacceptable**. In this manner, these devices shall be reported on form A-1C, Traffic Control Inspection Report, as **unacceptable**.

As an example, when an arrow board has too many lights out or it does not dim properly, the entire device will be considered as **unacceptable**, and it will be reported on form A-1C as such.

The following guidelines are to be used to rate a group of devices as **acceptable**, **marginal** or **unacceptable**. This guideline establishes Tollway intent. The Engineer is the sole judge as to the acceptability of devices and the action that is to be taken with regard to these guidelines.

8.1 Quality Guideline for Impact Attenuators, Temporary

The device shall be listed as Severe Use on IDOT's APPROVED LIST OF IMPACT ATTENUATORS, TEMPORARY.

Any element of the impact attenuator that has been damaged, deformed or bent will not be allowed and shall be repaired to meet NCHRP 350 or MASH requirements.

All elements of the device shall be in place and installed in accordance with the manufacturer's recommendations to meet NCHRP 350 or MASH requirements.

The devices shall be delineated with a terminal marker on the nose, and reflectors along the side.

8.2 Quality Guidelines for Warning Lights

This guideline applies to Type A and Type C low intensity, flashing, and steady burn lights furnished by a supplier, subcontractor, or contractor for traffic control in work zones.

Warning light type and placement shall be as specified in the applicable traffic control standard, Article 701.03(e) of the Tollway Supplemental Specifications. For all lights to be used in work zones, all the above requirements shall be met to the satisfaction of the Engineer.

Lights should be visible from 3000 feet under both day and night conditions. All lights shall meet approval of the Engineer.

EVALUATION GUIDE -- LIGHTS

Acceptable: When hundred percent (100%) of the Type A or C lights are lit and meeting the above requirements.

Marginal: When all the following conditions exist:

- 1) More than ninety percent (90%) of the Type A or C lights are lit.
- 2) No more than 3 consecutive lights failing.
- 3) The lights meet the above requirements.

Marginal for Tapers: When all the following conditions exist:

- 1) More than ninety percent (90%) of the Type A or C lights are lit.
- 2) The lights meet the above requirements.

Unacceptable: When any of the following conditions exist:

- 1) Less than ninety percent (90%) of the Type A or C lights are lit.
- 2) Four (4) or more consecutive lights failing.
- 3) The lights do not meet the above requirements.

Unacceptable for Tapers: When any of the following conditions exist:

- 1) Less than ninety percent (90%) of the Type A or C lights are lit.
- 2) The lights do not meet the above requirements.

8.3 Quality Guideline for Arrow Boards

This guideline applies to arrow boards that are furnished by a supplier, subcontractor, or contractor for traffic control in work zones.

Arrow board placement shall be as specified in IDOT Standard Highway 701901 and Article 710.03(f) of the Tollway Supplemental Specifications, or the Traffic Control Plan for the governing contract. For arrow boards to be used in work zones, all the above requirements shall be met to the satisfaction of the Engineer.

Any arrow board which is out of alignment from the driver's line of vision or not placed within 5° of a horizontal position (1"/1') shall be considered to be an unacceptable device. Article 1106.02(h) of the Standard Specifications contains specific distance requirements for an arrow board to be visible, if it is not legible at the required distance, it is an unacceptable device.

EVALUATION GUIDE -- ARROW BOARDS FLASHING ARROW MODE

Acceptable: No lights are out, and the arrow board is dimming properly.

Marginal: Two (2) or less lights out total, with only 1 light being out in the head, and the arrow board is dimming properly.

Unacceptable: When any of the following conditions exist:

- 1) Three (3) or more lights out total.
- 2) Two (2) or more lights out in the head of the arrow.
- 3) The arrow board is not dimming properly.

CAUTION MODE

Acceptable: No lights are out, and the arrow board is dimming properly.

Marginal: Minimum of 4 lamps operating and dimming properly.

Unacceptable: When either of the following conditions exist:

- 1) Three or less lamps operating.
- 2) The arrow board is not dimming properly.

8.4 Quality Guideline for Portable Changeable Message Signs (PCMS)

This guideline applies to Portable Changeable Message Signs that are furnished by a supplier, subcontractor, or contractor for traffic control in work zones.

PCMS placement shall be as specified in the applicable traffic control standard, Article 701.03(g) of the Tollway Supplemental Specifications, or the Traffic Control Plan for the governing contract. For a PCMS to be used in work zones, all the above requirements shall be met to the satisfaction of the Engineer.

Any PCMS which is not visible from 3000 feet under both day and night conditions and letters are not legible from a minimum of 600 feet for nighttime conditions and 800 feet for normal daylight conditions shall be considered an unacceptable device.

Any PCMS which is out of alignment from the driver's line of vision or not placed within 5° of a horizontal position (1"/1') shall be considered to be an unacceptable device.

EVALUATION GUIDE – Portable Changeable Message Signs

Acceptable: No lights are out, and the arrow board is dimming properly.

Marginal: Two (2) or less bulbs, discs, or LEDs are out in each character, with no more than four bulbs or discs out per message, and the PCMS board is dimming properly.

Unacceptable: When any of the following conditions exist:

- 1) Three (3) or more bulbs, discs or LEDs are out per character.
- 2) Five (5) or more out per message.

3) The PCMS board is not dimming properly.

8.5 Quality Guideline for Work Zone Pavement Marking

This guideline applies to Temporary pavement markings that are furnished by a supplier, subcontractor, or contractor for traffic control in work zones.

Temporary pavement markings placement shall be as specified in the governing contract traffic control standard, Section 703 of the Standard Specifications, and the governing contract Traffic Control Plan. Section 1095 of the Standard Specifications provides requirements for the pavement marking materials. All the above requirements shall be met to the satisfaction of the Engineer.

EVALUATION GUIDE -- WORK ZONE PAVEMENT MARKINGS

Acceptable: All pavement marking tape and paint required is in place and meets the above specifications.

Marginal: Ninety percent (90%) or more of all pavement marking tape or paint is present, and two or less consecutive skip lines are missing, and less than 50 feet of continuous solid line is missing or nonreflective.

Unacceptable: When any of the following conditions exist:

- 1) Less than ninety percent (90%) of all pavement marking tape or paint is present.
 - 2) Three or more consecutive skip lines are missing.
 - 3) **More than 50 feet of continuous solid line are missing or nonreflective.**
- 8.6 Quality Guideline for Reflectors on Pavement or Barrier Wall**

This guideline applies to reflectors used in work zones to delineate the pavement that are furnished by a supplier, subcontractor, or contractor for traffic control in work zones.

The placement of pavement reflectors shall be as specified in the applicable traffic control standard and the Traffic Control Plan. Articles 1096.02 and 1097.02 of the Standard Specifications provide requirements for the reflectors.

All the above requirements shall be met to the satisfaction of the Engineer.

The color of the reflector must be as specified in the contract, or the reflectors are unacceptable.

EVALUATION GUIDE -- BARRIER WALL REFLECTORS

Acceptable: All reflectors are in place and meet the above specifications.

Marginal: Ninety percent (90%) or more reflectors are present, having two or fewer consecutive reflectors missing.

Unacceptable: When either of the following conditions exists:

- 1) Less than ninety percent (90%) of all reflectors are present.
- 2) Three or more consecutive reflectors are missing.

8.6 Quality Guideline for Glare Screens on Barrier Wall

This guideline applies to glare screens used in work zones for placement on temporary concrete barrier that are furnished by a supplier, subcontractor, or contractor for traffic control in work zones.

Where specified on the governing contract, Modular Glare Screens shall be placed on Movable Barrier Walls per Section 638 of the Standard Specifications and IDOT Highway Standard 638001. All the above requirements shall be met to the satisfaction of the Engineer.

Please Note: The color of the glare shield utilized must be as specified in the contract, or these items will be deemed unacceptable.

EVALUATION GUIDE -- BARRIER WALL REFLECTORS AND GLARE SCREENS

Acceptable: All glare screen blades are in place and meet the above specifications.

Marginal: Ninety percent (90%) or more glare screen blades are present.

Unacceptable: When either of the following conditions exists:

- 1) Less than ninety percent (90%) of all glare screen blades are present.
- 2) Three or more consecutive glare screen blades are missing, or one full section of glare screen shielding is missing.

APPENDIX A

CONSTRUCTION WORK ZONE ARRAY



Construction Zone Signs

Acceptable



&



Unacceptable
Signs

Correct Work Zone array includes:

- Initial Advance Warning
- Construction Communications
- Portable Changeable Message Signs (PCMS)
- Subsequent Advance Warnings
- Speed Reduction Advisory
- Speed Limit Array
- Lane Shift
- Taper
- Additional Speed Limit Array
- Emergency Pull off Advance and Location Indicator
- Constructions Communications
- Delineators and Guidance
- Lane Shift
- Taper
- End Work Zone
- End Work Zone Speed
- Construction Communications

Initial Advance Warning



PCMS



Guidance



Initial Construction Communications



Subsequent Speed Array



Guidance



Advance Warning



Emergency Area Advance



End Work Zone Speed



Speed Limit Array



Emergency Pull Off



End of Construction Communications



Lane Shift



Delineators and Guidance



Avoid These Problems

Blockage



Illegible/Obscure



Equipment Blockage



Personal vehicles



Unclear Construction Entrance



Remove unused devices



Unguarded Re-entry

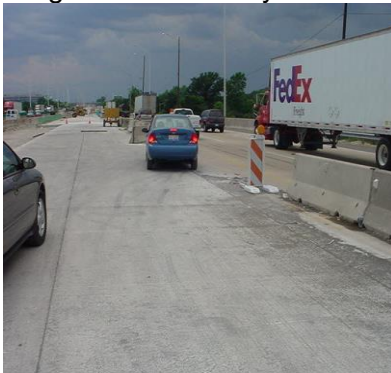

Improper Re-entry



Improper Attire/positioning



The following are in the same construction zone – lane use must be consistent and clear.

These are on same segment – first right, then center, then right???



Mis-stacked array and inconsistent lane usage message



Work Zone Speed arrays are always to be:

- Orange "Work Zone"
- Speed Limit
- "Begins" (when appropriate)
- Fine panel

In a segment, all signs should be same dimension and font – overlays must be complete

Properly signed for mainline and entrance ramp



All existing panels must be completely covered or removed and reinstalled at contract completion

Not acceptable



Misdirection

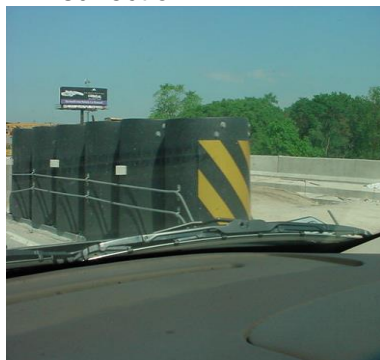

Incomplete



Blocked and mis-stacked



Clustered, confusing



Cover ok, spacing poor



APPENDIX B

TRAFFIC CONTROL INSPECTION REPORT

Form A-1C, Traffic Control Inspection Report is available on the Web-Base Management System;

Location: e-Builder

Project 0016 WBPM e-Builder Program Wide

Folder: Documents \ Templates and Forms \ A - Forms