

<b>Tollway Standard Drawing Revisions</b>
---

Section C	Guardrail / Median Barrier	
	Standard	Modification Summary
		Effective 11/1/2012
	<b>C1</b>	<b>Galvanized Steel Plate Beam Guardrail</b>
	Sheet 1	Modified Aggregate Shoulder Special Type C Depth from 3" to 6"
	Sheet 2	Added 9' post identification stamp
	<b>C3</b>	<b>Single Face Reinforced Barrier Wall</b>
		Added gutter transition taper detail for frame and grate.
		Added new construction joint and expansion joint details
		Revised Note 3
	<b>C4</b>	<b>Concrete Shoulder Barrier Transition</b>
		Modified barrier height at crash wall from 4'-6" to 5'-0".
		Added new construction joint and expansion joint details
	<b>C5</b>	<b>Concrete Barrier 42"</b>
		Added gutter transition taper detail for frame and grate.
		Added new construction joint and expansion joint details
		Revised Notes 1, 2
	<b>C6</b>	<b>Traffic Barrier Terminal Type T1 (Special)</b>
		Modified Aggregate Shoulder Special Type C Depth from 3" to 6"
	<b>C7</b>	<b>Traffic Barrier Terminal Type T2</b>
		Modified Aggregate Shoulder Special Type C Depth from 3" to 6"
		Modified wood post dimensions.
	<b>C8</b>	<b>Traffic Barrier Terminal Type T5</b>
		Modified Aggregate Shoulder Special Type C Depth from 3" to 6"
	<b>C9</b>	<b>Traffic Barrier Terminal Type T6</b>
		Modified Aggregate Shoulder Special Type C Depth from 3" to 6"
		Added Note 12
	<b>C10</b>	<b>Traffic Barrier Terminal Type T6B</b>
		Modified Aggregate Shoulder Special Type C Depth from 3" to 6"
		Added Note 9
	<b>C12</b>	<b>Traffic Barrier Terminal Type T1-A (Special)</b>
		Modified Aggregate Shoulder Special Type C Depth from 3" to 6"
	<b>C13</b>	<b>Concrete Median Barrier Transition at Bridge Piers</b>
		Modified barrier height at crash wall from 4'-6" to 5'-0".
		Extended transition taper length from 28' to 30'.

 New Sheet

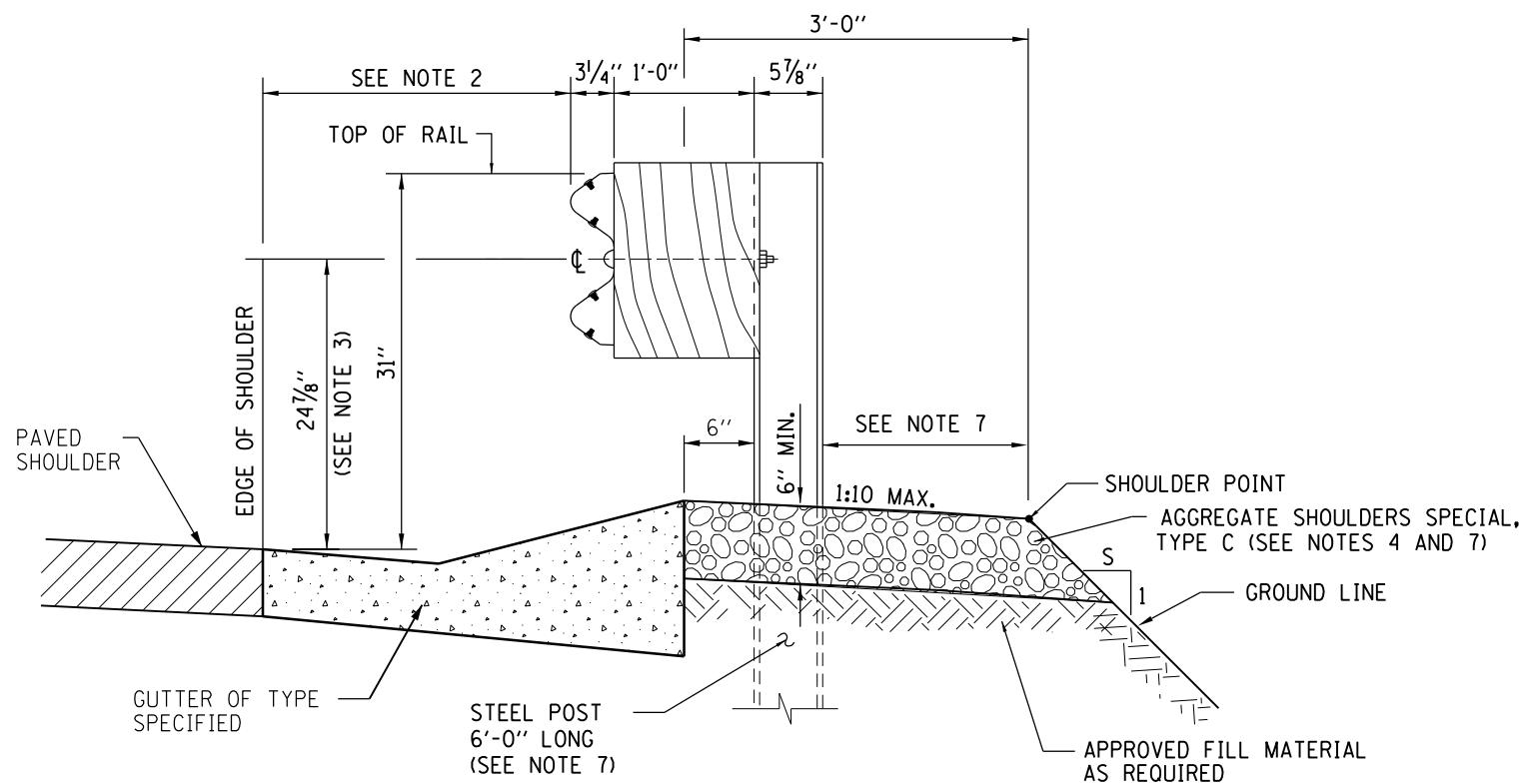

SECTION WITH GUTTER

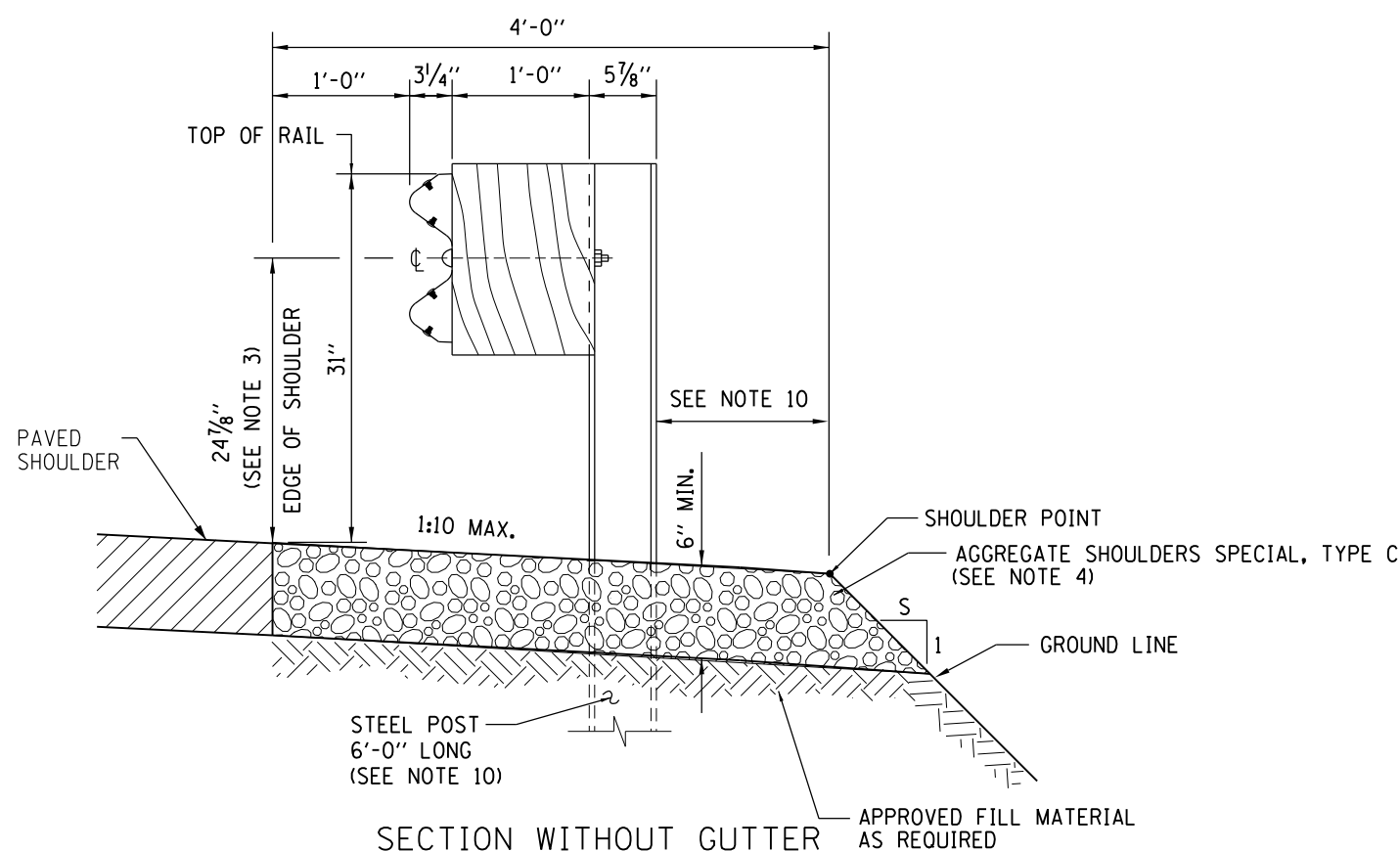

SECTION WITHOUT GUTTER

NOTES:

- 1' OFFSET FROM EDGE OF PAVED SHOULDER TO FACE OF RAIL IS TYPICAL FOR ALL INSTALLATIONS EXCEPT AS OTHERWISE DETAILED IN THE PLAN DRAWINGS.
- WHERE GUTTERS SUCH AS TYPE G-2 , G-3 ARE REQUIRED IN FRONT OF THE GUARDRAIL, THE POSTS SHALL BE LOCATED 6" BEHIND THE GUTTER, OR AS OTHERWISE DETAILED IN THE PLANS. THE OFFSET FROM THE EDGE OF SHOULDER TO THE FACE OF THE GUARDRAIL SHALL BE AS SHOWN ON STANDARD B28.
- THE 24 7/8" TYPICAL RAIL HEIGHT IS MEASURED FROM EXISTING SURFACE 1' IN FRONT OF RAIL, OR FROM EDGE OF SHOULDER/EDGE OF GUTTER WHEN EDGE IS MORE THAN 1' IN FRONT OF RAIL TO CENTER OF RAIL.
- AGGREGATE SHOULDERS SPECIAL, TYPE C SHALL COMPLY WITH THE REQUIREMENTS OF THE TOLLWAY RECURRING SPECIAL PROVISION. WHERE GUTTER IS PROPOSED WITH GUARDRAIL, A 3" MINIMUM THICKNESS OF AGGREGATE SHOULDERS SPECIAL, TYPE C SHALL BE PLACED BEHIND CURB. FOR GUARDRAIL WITHOUT CURB & GUTTER, AGGREGATE SHOULDER, OF THE SAME THICKNESS SHALL BE PLACED FROM THE EDGE OF PAVED SHOULDER SLOPING AWAY TO A 3" MIN. THICKNESS.
- AGGREGATE SHOULDERS SPECIAL, TYPE C SHALL EXTEND A MINIMUM OF 1' BEHIND POST OR GUARDRAIL, WHICHEVER IS FURTHER, EXCEPT AS DETAILED ELSEWHERE IN THE PLANS.
- PLASTIC BLOCK-OUTS SHALL NOT BE ALLOWED AS A SUBSTITUTE FOR WOOD BLOCK-OUTS ON NEW INSTALLATIONS.
- WHEN  $S \leq 3$  AND 3'-0" MIN. AGGREGATE SHOULDER CANNOT BE MET, THE POST LENGTH SHALL BE 9'-0" AND THE MIN. AGGREGATE SHOULDER SHALL BE 1'-0" MEASURED DISTANCE BEHIND POST TO THE SHOULDER POINT.
- ALL SLOPES ARE EXPRESSED AS UNITS OF VERTICAL DISPLACEMENT TO UNITS OF HORIZONTAL DISPLACEMENTS (V:H).
- UNDER NO CIRCUMSTANCES SHALL AN EXISTING GUARDRAIL, THAT WAS DESIGNED USING A PREVIOUS STANDARD, BE EXTENDED, ATTACHED TO OR MODIFIED IN ANYWAY FROM ITS ORIGINAL DESIGN. IF ANY MODIFICATION IS REQUIRED AND A PROPER BARRIER WARRANT HAS BEEN COMPLETED, THE ENTIRE BARRIER INSTALLATION SHALL BE COMPLETELY REMOVED AND REPLACED WITH A NEW SYSTEM THAT CONFORMS TO THE CURRENT STANDARD.
- WHEN  $S \leq 3$ , THE POST LENGTH SHALL BE 9'-0" AND 4' AGGREGATE SHOULDER WIDTH MAINTAINED.
- THE GUARDRAIL SYSTEM HAS BEEN PERFORMANCE-TESTED FOR CRASHWORTHINESS UNDER PROCEDURES DEFINED IN THE NATIONAL COOPERATIVE HIGHWAY RESEARCH PROGRAM (NCHRP) REPORT 350. NO MODIFICATION TO THIS STANDARD DRAWING SHALL BE PERMITTED.
- GUARDRAIL POSTS SHALL NOT BE INSTALLED IN CONCRETE OR ASPHALT PAVEMENT. WHEN NECESSARY USE LEAVE-OUT DETAIL ON SHEET 4 OF 4 OF THIS SERIES.
- GUARDRAIL POSTS SHALL NOT BE ATTACHED TO ANY STRUCTURE.



GUARDRAIL INSTALLATION DETAILS

APPROVED *Paul Kovacs* CHIEF ENGINEER DATE 7-1-2009

REVISIONS		GALVANIZED STEEL PLATE BEAM GUARDRAIL
2-7-2012	ADDED TYPE C GUARDRAIL, MODIFIED LEAVE-OUT CAP MATERIAL AND REVISED NOTES	
11-1-2012	MODIFIED AGGREGATE SHOULDERS	
		STANDARD C1-06

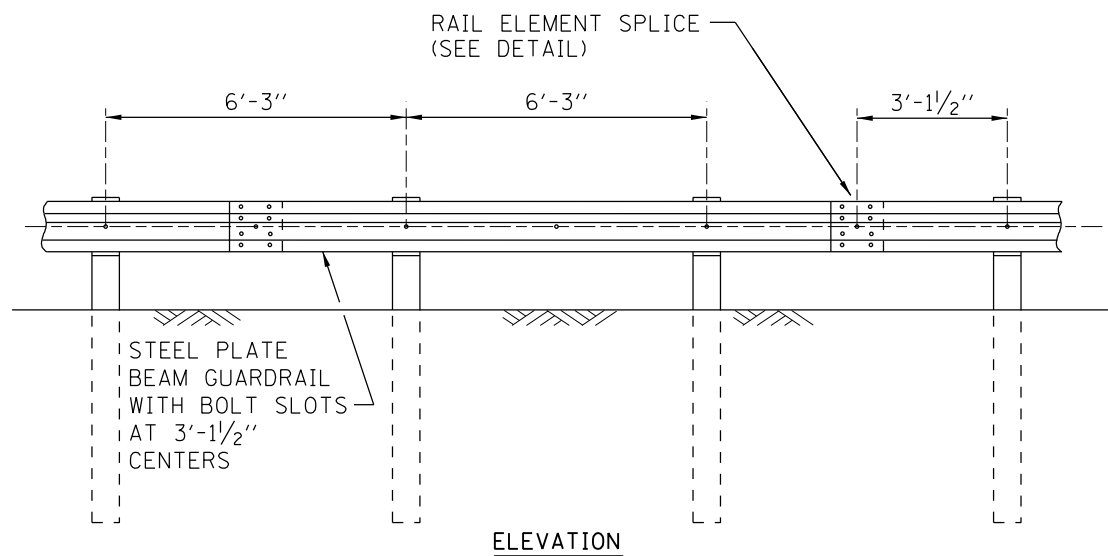

**TYPE A**  
6'-3" TYPICAL POST SPACING

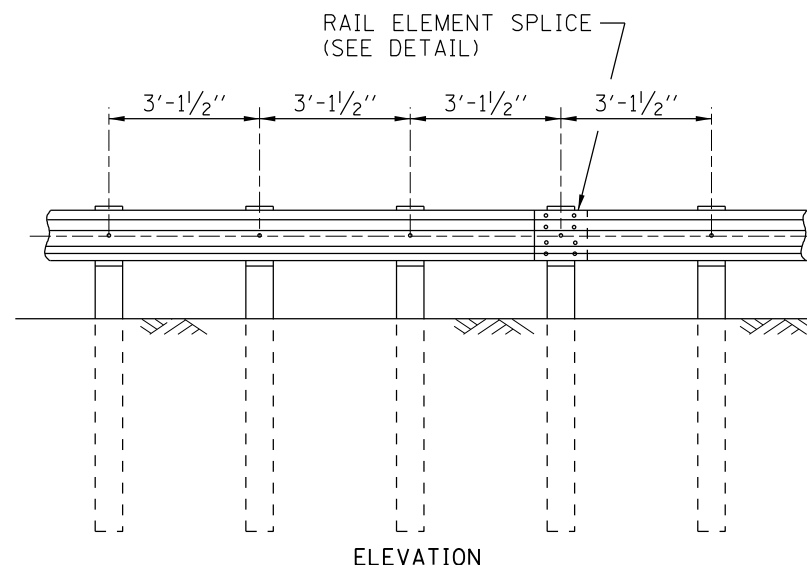

**TYPE B**  
3'-1/2" 1/2 POST SPACING

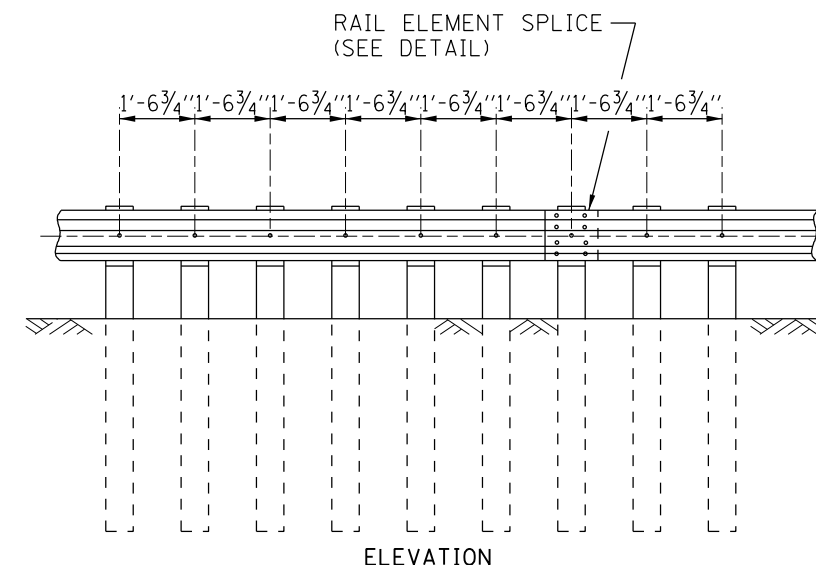

**TYPE C**  
1'-6 3/4" 1/4 POST SPACING

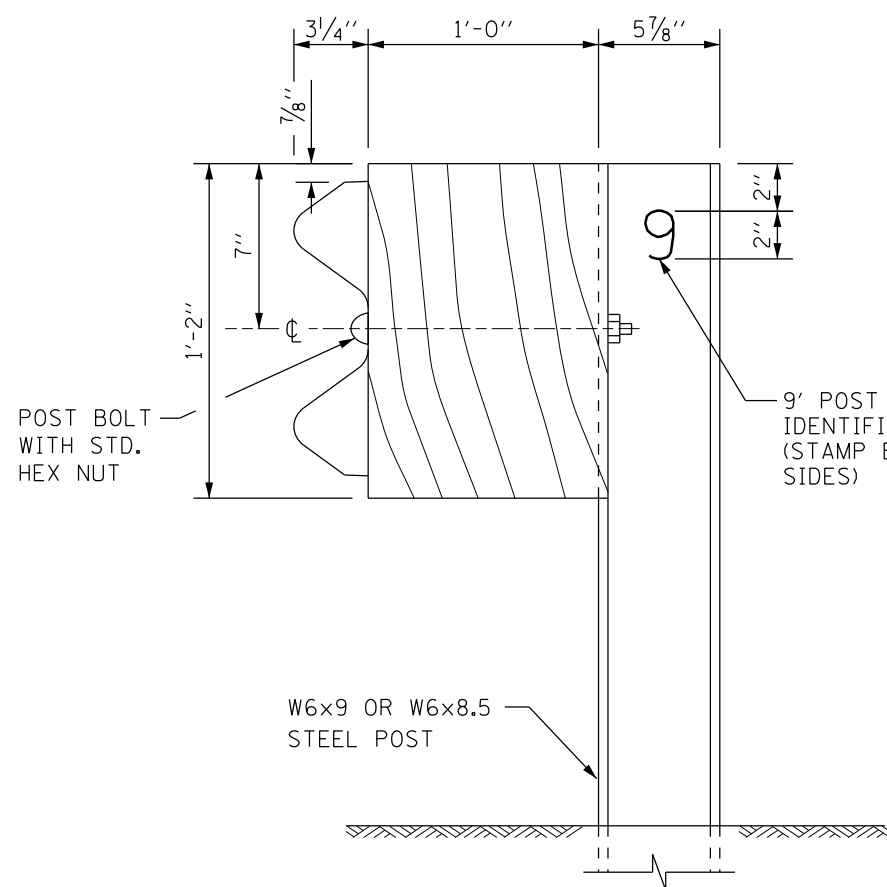

**STEEL POST CONSTRUCTION**

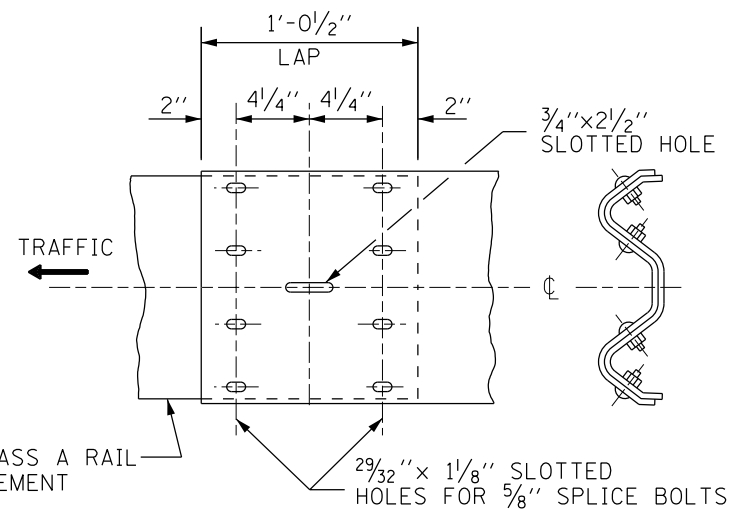

**RAIL ELEMENT SPLICE**

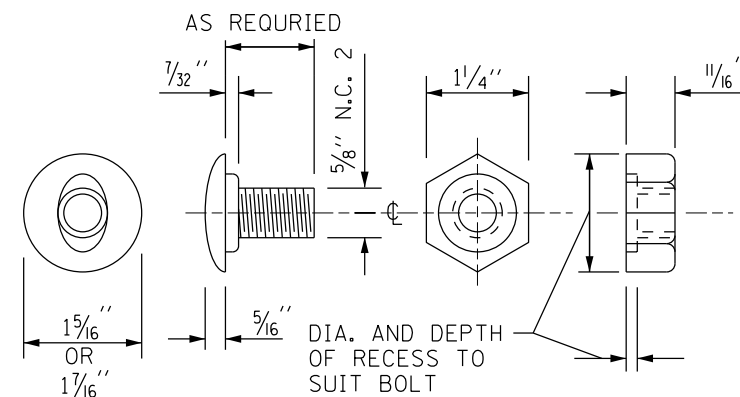

**POST OR SPLICE BOLT & NUT**

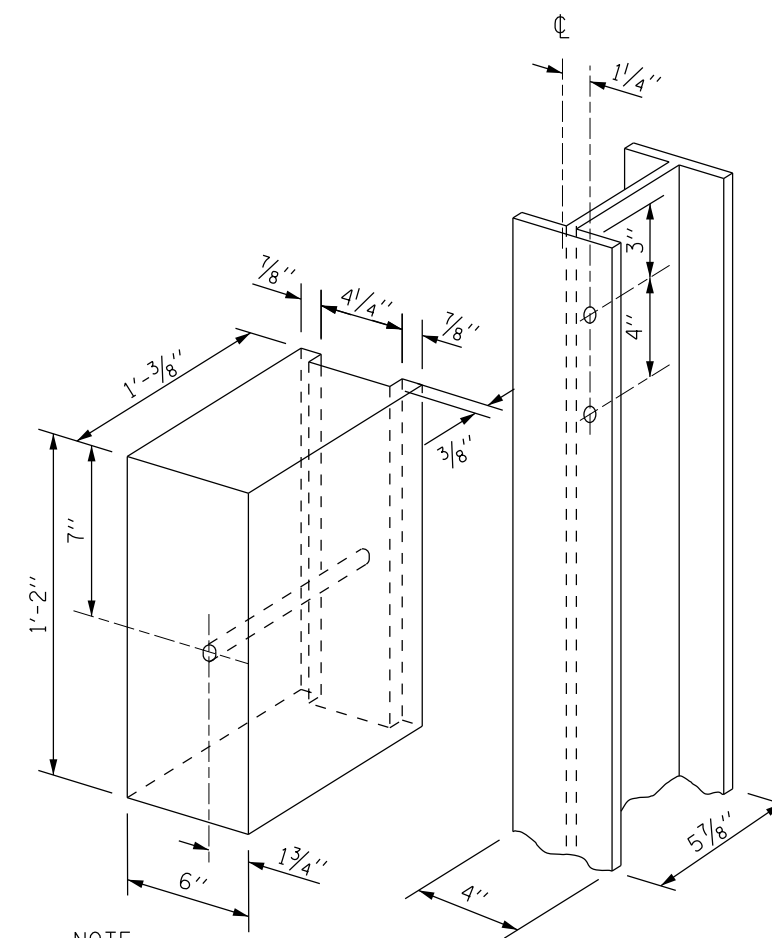

**WOOD BLOCK-OUT AND STEEL POST DETAILS**

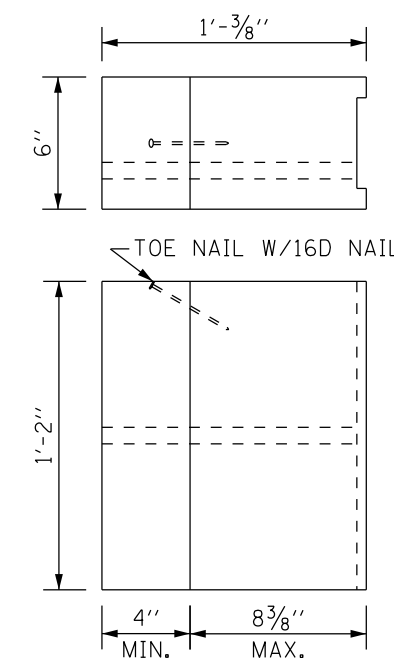

**TWO-PIECE WOOD BLOCKOUT OPTION**

TABLE 1			
V	W	L	
		STEEL POST	WOOD POST
0 - 16 1/8"	24"	21"	23"
> 16 1/8" - 28 1/8"	12"	8"	10"
> 28 1/8" - 40 1/8"	12" - 0 (*)	8"	10"

\* V+W=40 1/8"

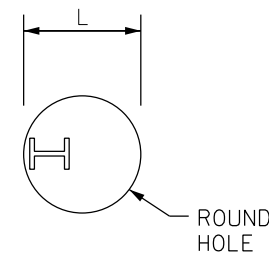

PLAN

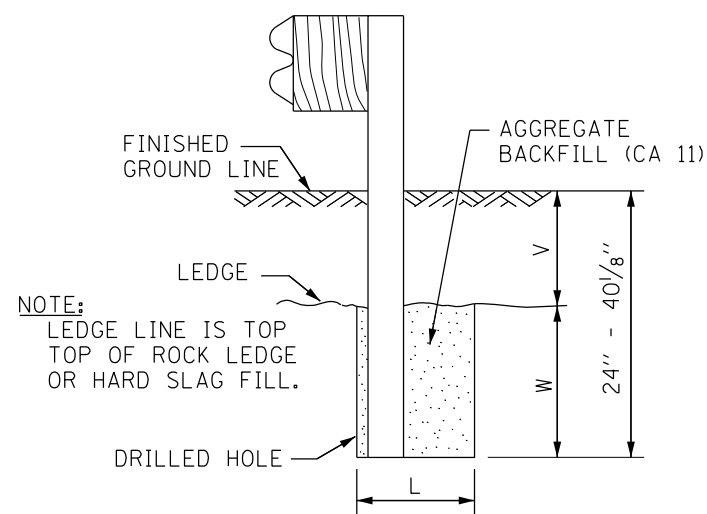

ELEVATION

FOOTING FOR POST WHEN IMPERVIOUS MATERIAL IS ENCOUNTERED

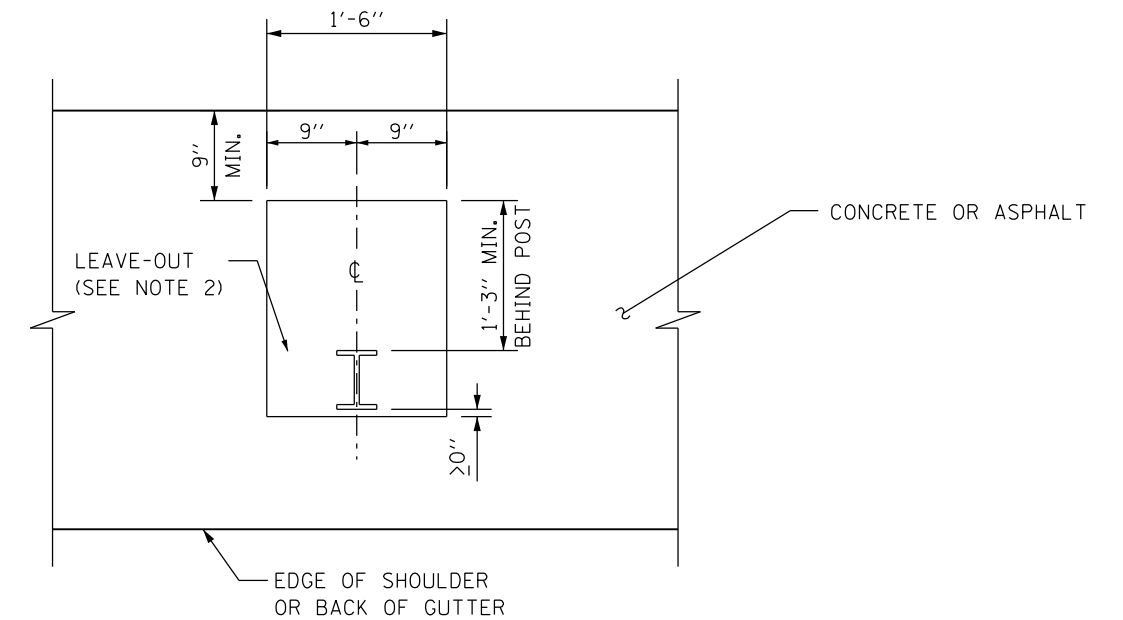

PLAN

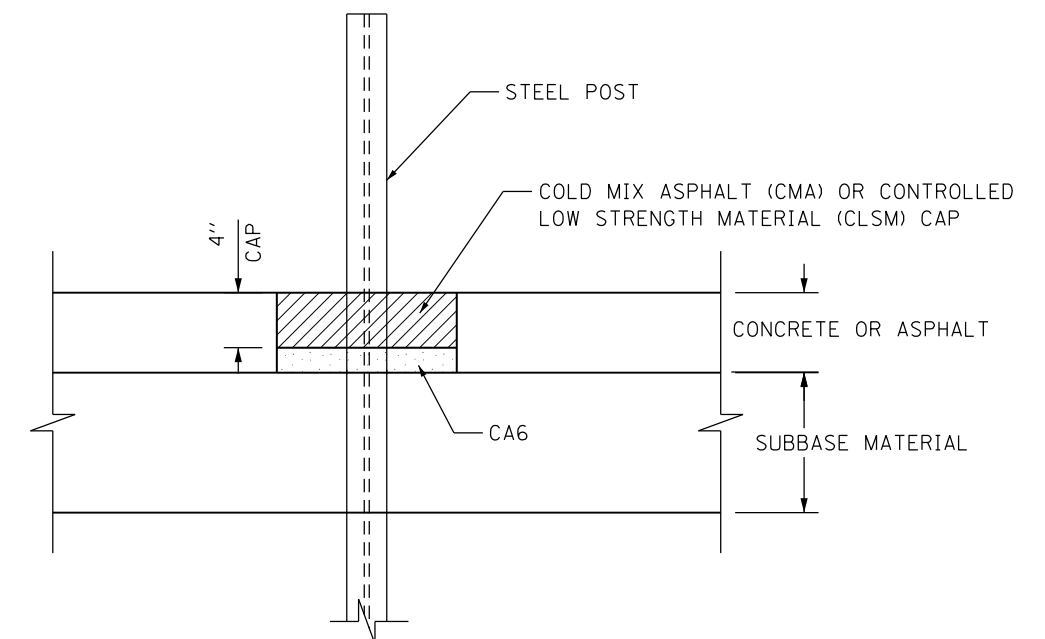

ELEVATION

LEAVE-OUTS

NOTES:

1. CAP SHALL BE INSTALLED TO MATCH THE EXISTING CROSS SLOPE.
2. THE LEAVE-OUT SHALL BE DEFINED AS THE AREA AROUND THE POST THAT IS EITHER OMITTED FROM THE NEW CONSTRUCTION OR REMOVED FROM THE EXISTING CONCRETE OR ASPHALT.

TABLE 2

BARRIER CLEARANCE DISTANCE			
GUARDRAIL SYSTEM	POST SPACING	DESIRABLE BARRIER CLEARANCE DISTANCE	MINIMUM BARRIER CLEARANCE DISTANCE
TYPE A	6'-3"	42"	28"
TYPE B 1/2 POST SPACING	3'-1 1/2"	30"	23"
TYPE C 1/4 POST SPACING	1'-6 3/4"	24"	14"

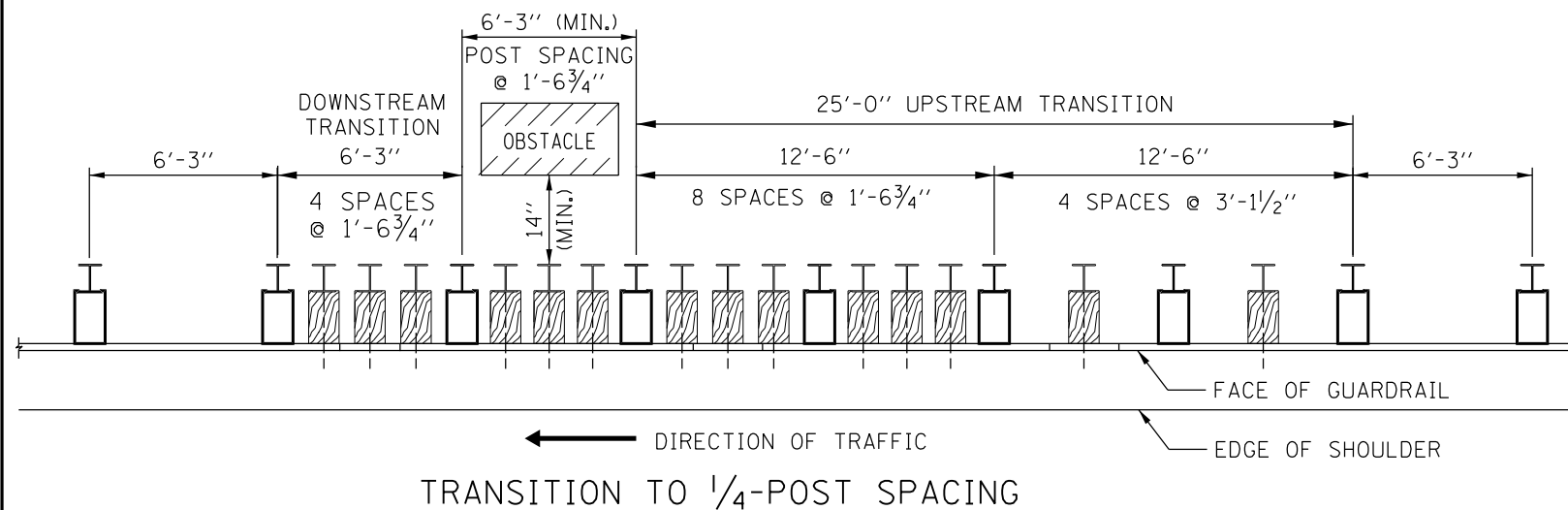
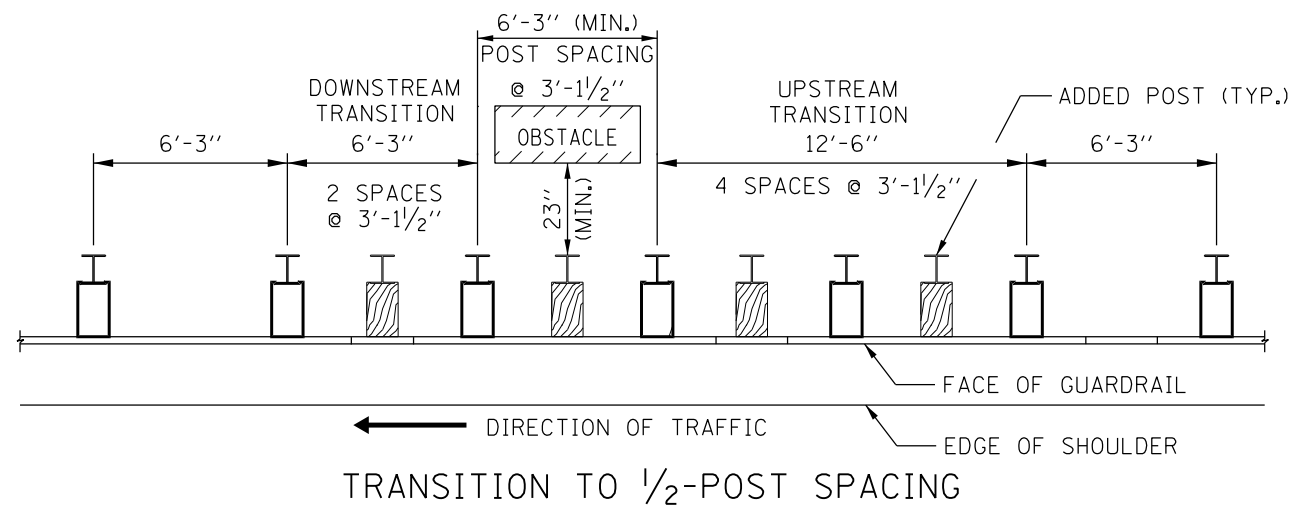

**NOTES:**

- DESIRABLE BARRIER CLEARANCE DISTANCES SHALL BE USED FOR ALL NEW INSTALLATIONS.
- MINIMUM BARRIER CLEARANCE DISTANCES ARE ONLY TO BE USED FOR EXISTING OBSTACLES.
- WHEN LENGTH OF OBSTACLES IS 1'-3" OR LESS, THE DOWNSTREAM TRANSITION SHALL BE OMITTED.

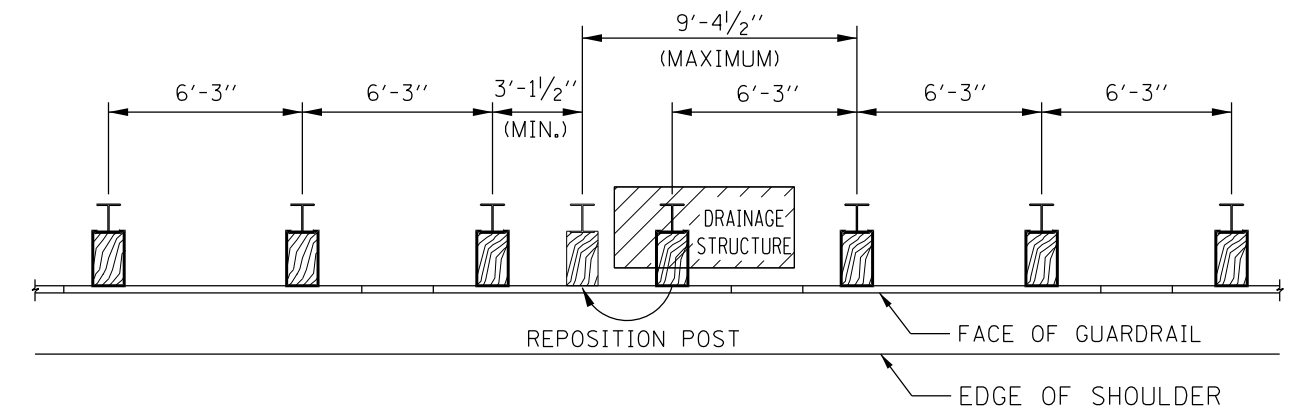

TYPE A GUARDRAIL-DRAINAGE STRUCTURE CONFLICT  
ONE POST

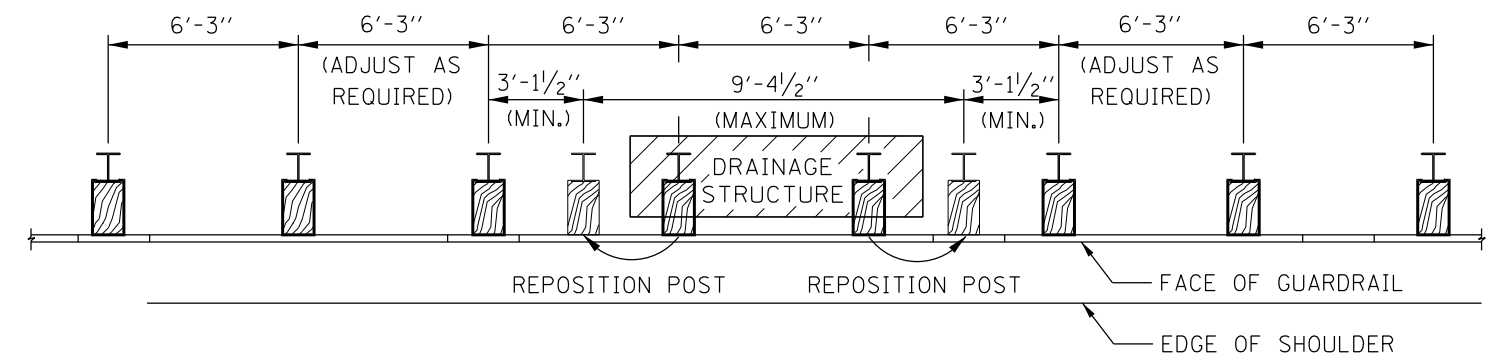

TYPE A GUARDRAIL - DRAINAGE STRUCTURE CONFLICT  
TWO POSTS

**NOTES:**

- GUARDRAIL POSTS SHALL NOT BE ELIMINATED; ALL POSTS MUST BE USED.
- GUARDRAIL POSTS SHALL NOT BE SET BACK TO AVOID CONFLICTS WITH A DRAINAGE STRUCTURE.
- NO MODIFICATIONS OF ANY KIND TO THE TRANSITION POST SPACING ARE ALLOWED.

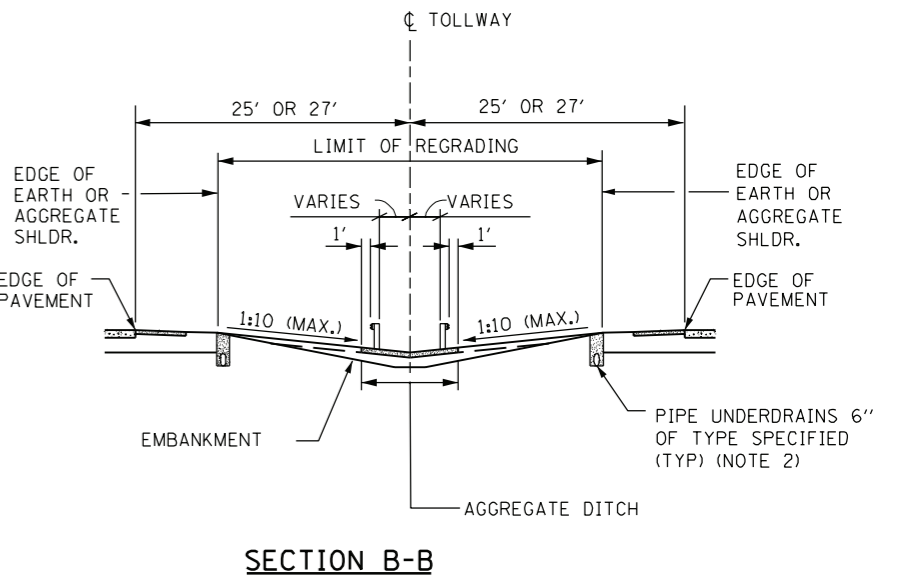
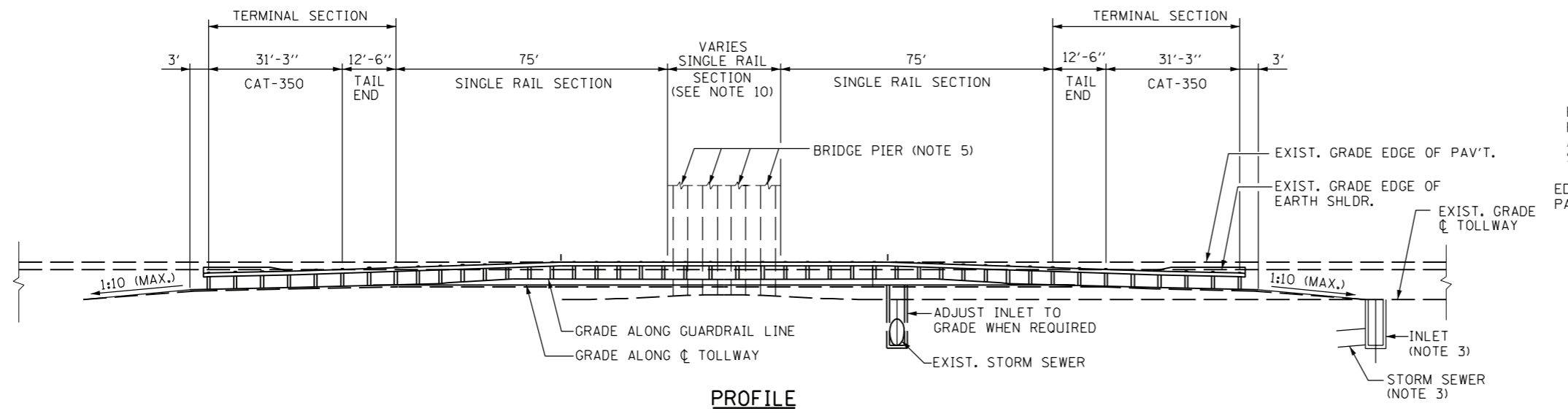
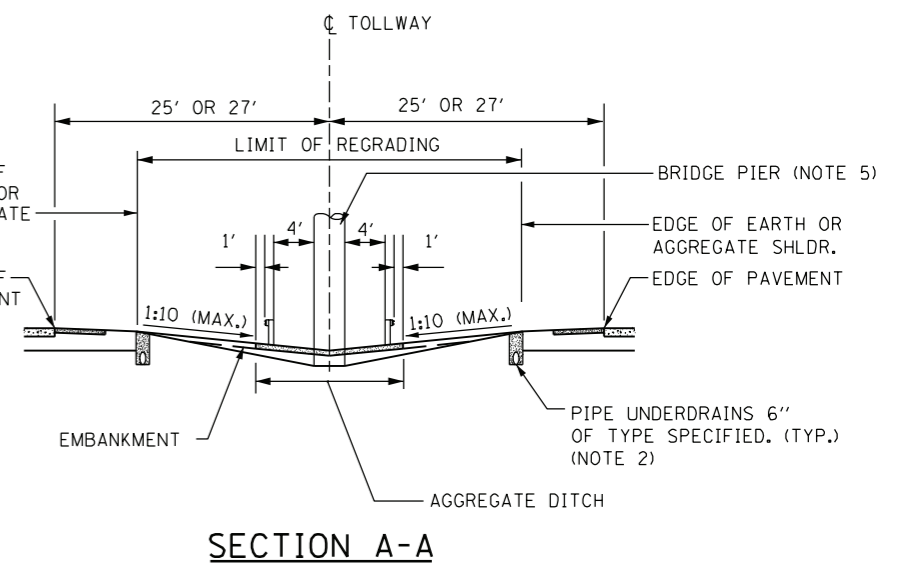
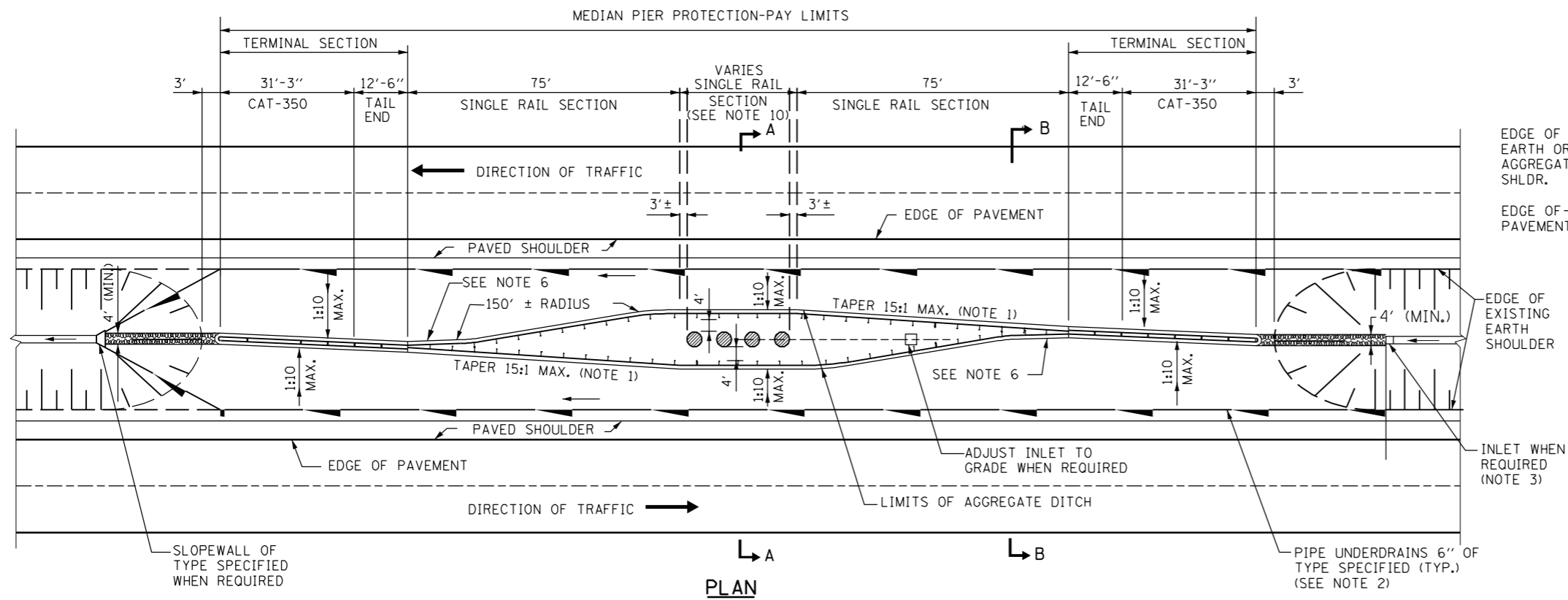

**NOTES:**

- FLATTER RATE OF TAPER MAY BE USED WHERE REQUIRED TO AVOID DAMAGE TO EXISTING STORM SEWERS.
- PIPE UNDERDRAIN REQUIRED IN SAG VERTICAL CURVE OR WHEN FROST HEAVE IS EXPECTED.
- AN INLET IS TO BE PROVIDED WHEN REQUIRED. THE INLET SHALL BE CONNECTED TO THE NEAREST DOWNSTREAM INLET OR CULVERT.
- MAXIMUM CROSS SLOPE FROM THE EDGE OF THE EARTH SHOULDER TO THE FACE OF THE RAIL SHALL BE 1:10.
- BRIDGE PIER OR OVERHEAD SIGN PIER.
- SINGLE W6x8.5 STEEL POST WITH BLOCKOUTS MAY BE USED FOR THIS POST.
- RAIL HEIGHT SHALL BE MEASURED FROM EXISTING SURFACE 1'-0" IN FRONT OF RAIL.
- SLOPE RATIOS ARE EXPRESSED AS UNITS OF VERTICAL DISPLACEMENT TO UNITS OF HORIZONTAL DISPLACEMENT (v:h).
- TRAFFIC BARRIER TERMINAL SHALL BE IN ACCORDANCE WITH THE MANUFACTURE'S DETAILS AND SPECIFICATIONS.
- SEE PLAN FOR LIMITS.
- THE GUARDRAIL SYSTEM HAS BEEN PERFORMANCE-TESTED FOR CRASHWORTHINESS UNDER PROCEDURES DEFINED IN THE NATIONAL COOPERATIVE RESEARCH PROGRAM (NCHRP) REPORT 350. NO MODIFICATION ANY KIND TO THIS STANDARD DRAWING SHALL BE PERMITTED.



DATE	REVISIONS
7-1-2009	DITCH DIMENSION ON SECTION A-A MODIFIED GUARDRAIL BARRIER TERMINAL DIMENSIONS
	REVISED NOTES
3-1-2010	ADDED TERMINAL TAIL END SECTION
	REVISED NOTES

MEDIAN PIER PROTECTION  
STANDARD C2-02

APPROVED: *Paul Kovacs* CHIEF ENGINEER DATE 7-1-2009

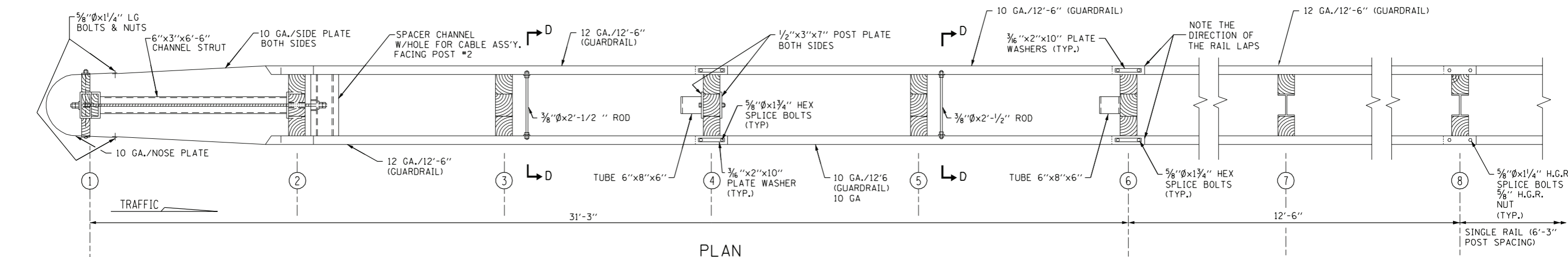

PLAN

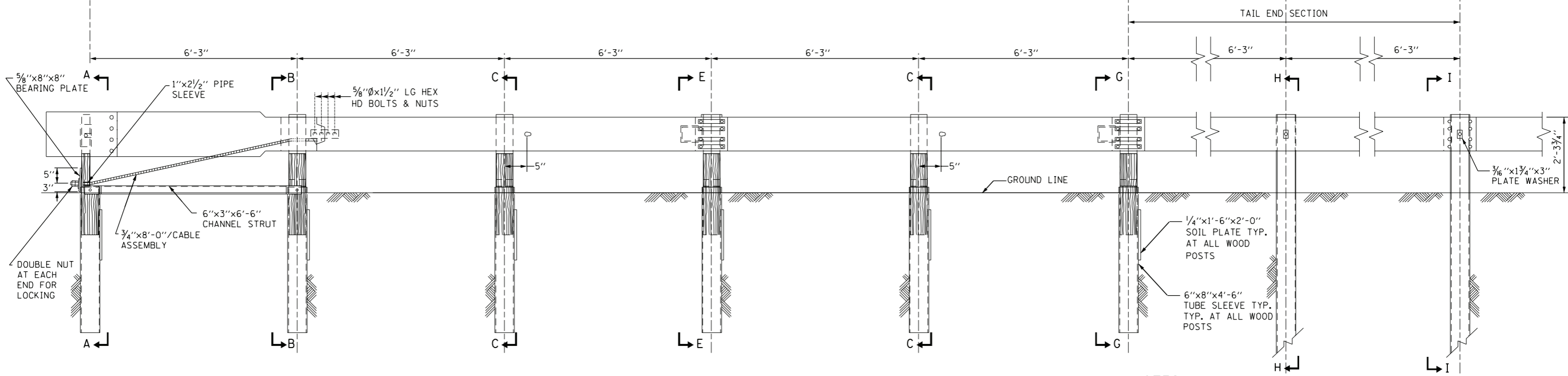

ELEVATION

MEDIAN PIER PROTECTION-TERMINAL SECTION

NOTES:

1. RAIL ELEMENTS, BOLTS, NUTS AND WASHERS SHALL BE HOT DIP GALVANIZED IN ACCORDANCE WITH THE STANDARD SPECIFICATIONS AND AASHTO M232 (ASTM A-153).
2. THE BOLTS, NUTS AND WASHERS SHALL CONFORM TO THE REQUIREMENTS OF ASTM A-307, GRADE A. HIGH STRENGTH BOLTS, NUTS AND WASHERS SHALL CONFORM TO AASHTO M164 (ASTM A-325).
3. POSTS, BLOCKS, PLATES AND MISCELLANEOUS ACCESSORIES SHALL CONFORM TO THE REQUIREMENTS OF AASHTO M183 (ASTM A-36) AND SHALL BE GALVANIZED IN ACCORDANCE WITH AASHTO M111 (ASTM A-123).
4. THE WOOD TERMINAL POSTS SHALL BE TREATED AND CONFORM TO THE REQUIREMENTS OF THE STANDARD SPECIFICATIONS.
5. HOLLOW STRUCTURAL TUBING SHALL CONFORM TO ASTM-500, GRADE B OR A-501.
6. THE 3/16" STEEL PLATES SHALL BE GALVANIZED IN ACCORDANCE WITH THE REQUIREMENTS OF AASHTO M232 (ASTM A-153).

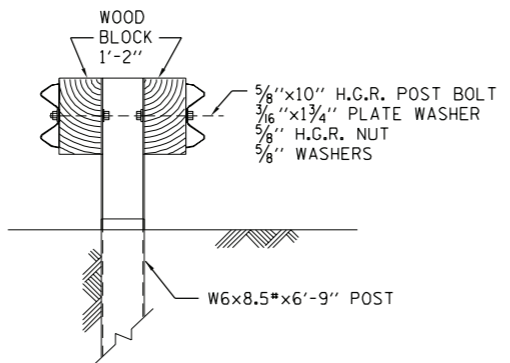

SECTION H-H ①

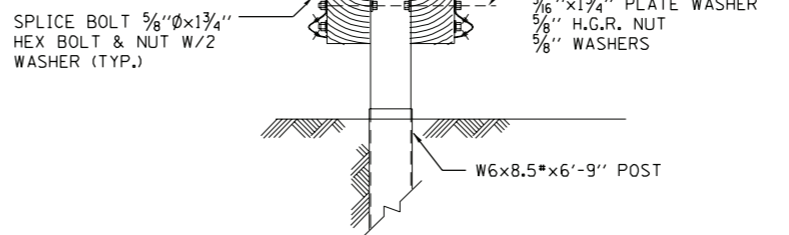

SECTION I-I ②

MEDIAN PIER PROTECTION-TERMINAL SECTION

APPROVED: *Paul Kovacs* CHIEF ENGINEER DATE 7-1-2009.



MEDIAN PIER PROTECTION

STANDARD C2-02

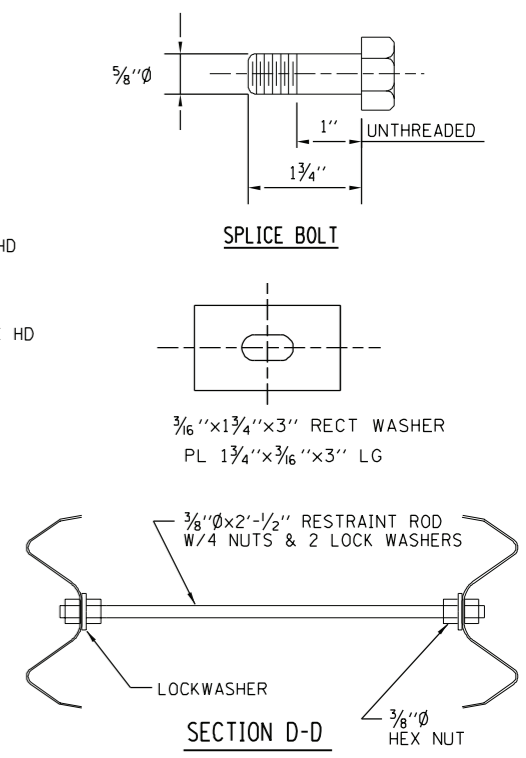
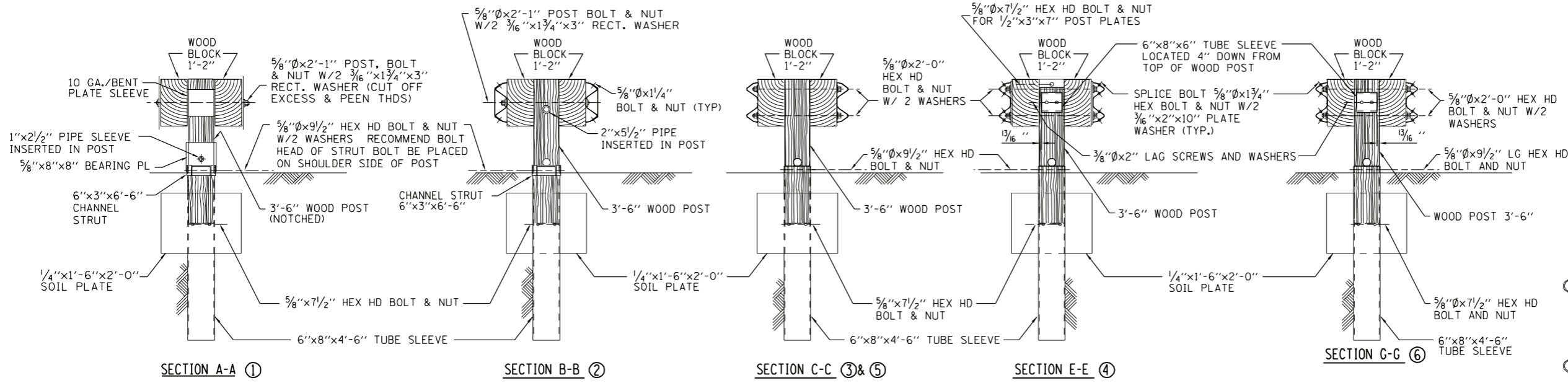

MEDIAN PIER PROTECTION-TERMINAL SECTION

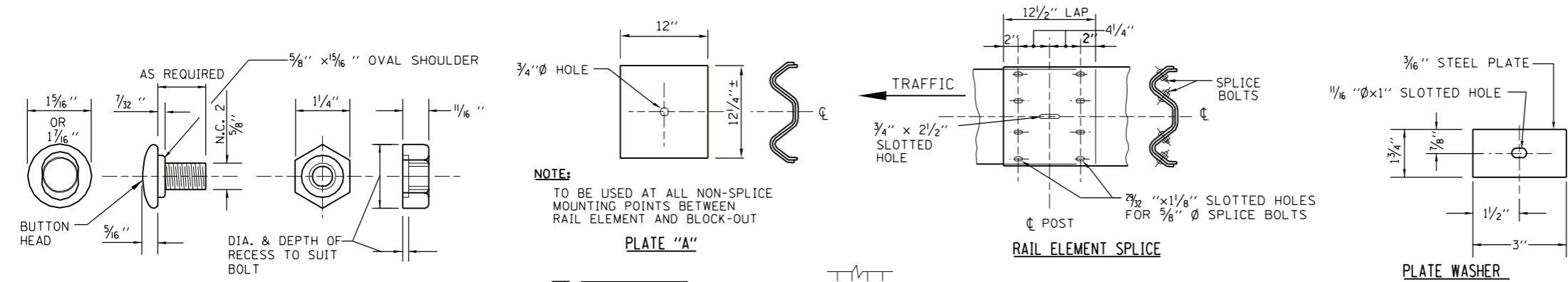

- NOTES:**
- ALL HOLES IN POSTS AND BLOCK-OUTS SHALL BE 3/4"Ø UNLESS OTHERWISE NOTED.
  - IN THE EVENT OF AN OBSTRUCTION PREVENTING POST INSTALLATION, UP TO TWO (2) CONSECUTIVE POSTS MAY BE OMITTED IF 2-PLY GUARDRAIL PANELS ARE USED FROM THIS LENGTH.
  - RAIL ELEMENT SHALL BE FURNISHED IN NOMINAL LENGTHS OF 12'-6". AN ALTERNATE 25'-0" NOMINAL LENGTH MAY BE FURNISHED AT THE OPTION OF THE CONTRACTOR.
  - ALL RAIL ELEMENTS AND ACCESSORIES SHALL CONFORM TO STANDARD SPECIFICATIONS UNLESS OTHERWISE NOTED.
  - THE CONTRACTOR SHALL LOAD TEST 10 PERCENT OF ALL EXPANSION ANCHOR BOLTS IN INSTALLATION IN THE PRESENCE OF THE ENGINEER. THE EQUIPMENT AND METHOD USED SHALL MEET THE APPROVAL OF THE ENGINEER. THE MINIMUM TEST LOAD SHALL BE 8,000 POUNDS FOR 5/8"Ø BOLTS IN DIRECT OF PULL FOR EACH ANCHOR THAT FAILS THE TEST REQUIREMENTS, TWO MORE ANCHOR BOLTS, PICKED BY THE ENGINEER SHALL BE TESTED. EACH ANCHOR BOLT THAT FAILS TO MEET THE TEST REQUIREMENTS SHALL BE RESET OR REMOVED AND THE HOLE DRILLED DEEPER. ALL RESET ANCHOR BOLTS SHALL MEET THE MINIMUM TEST REQUIREMENTS.
  - THE MAXIMUM POST SPACING SHALL BE 6'-3".

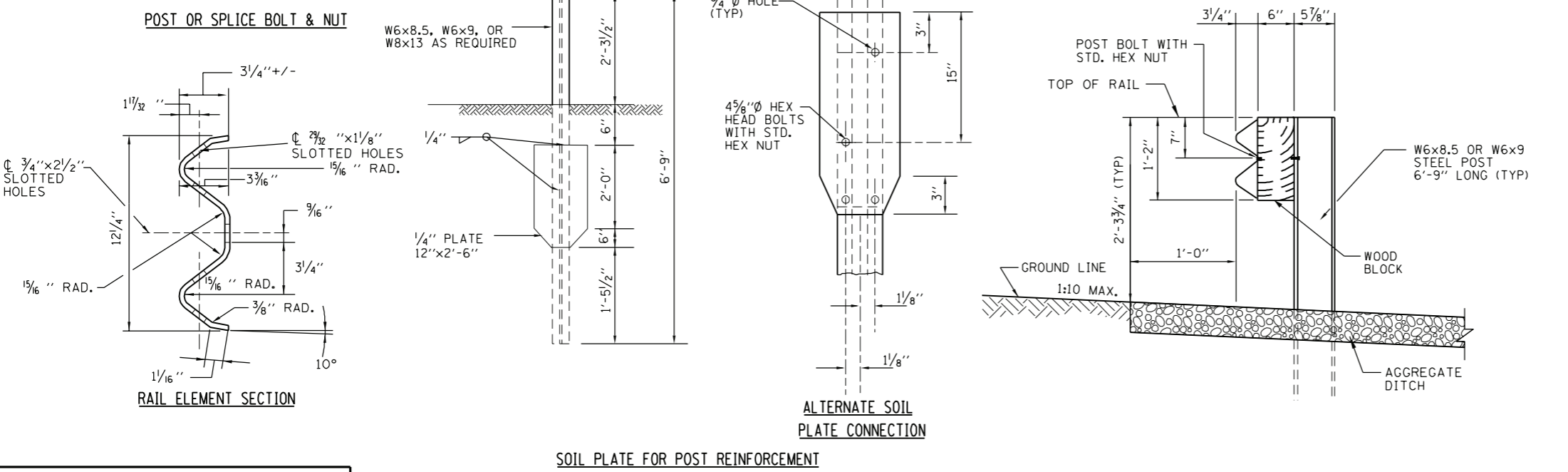

MEDIAN PIER PROTECTION-SINGLE RAIL SECTION



MEDIAN PIER PROTECTION

STANDARD C2-02

APPROVED: *Paul Kovacs* CHIEF ENGINEER DATE: 7-1-2009



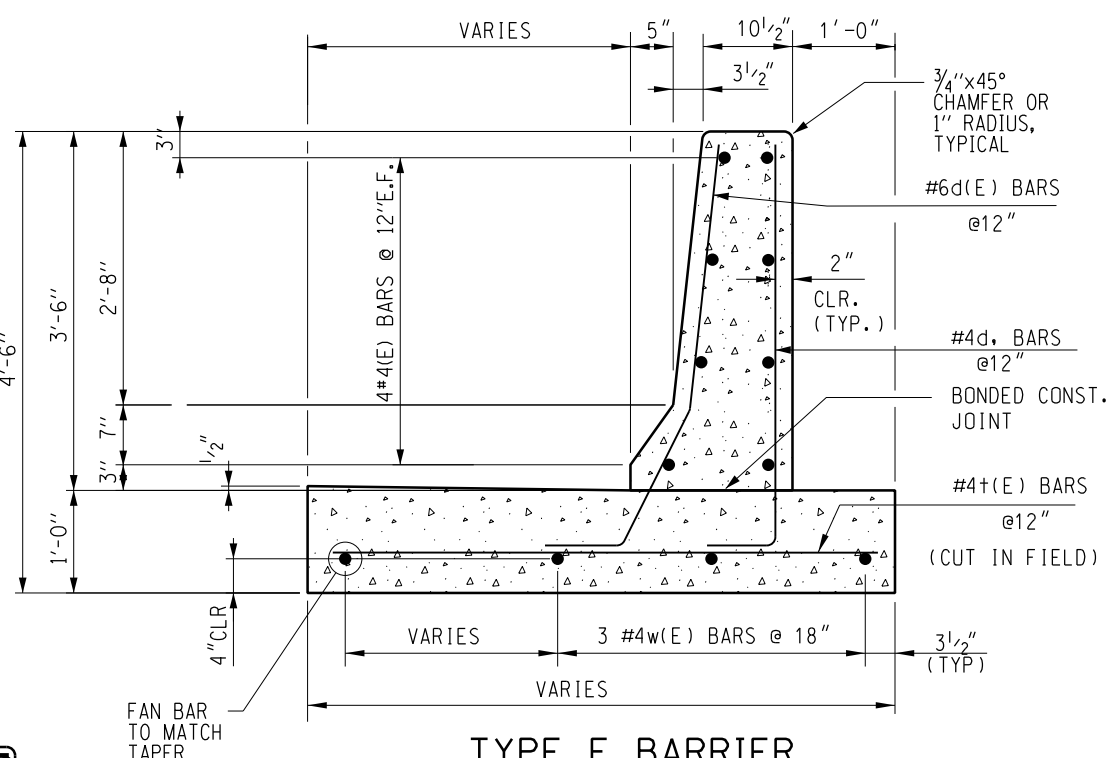
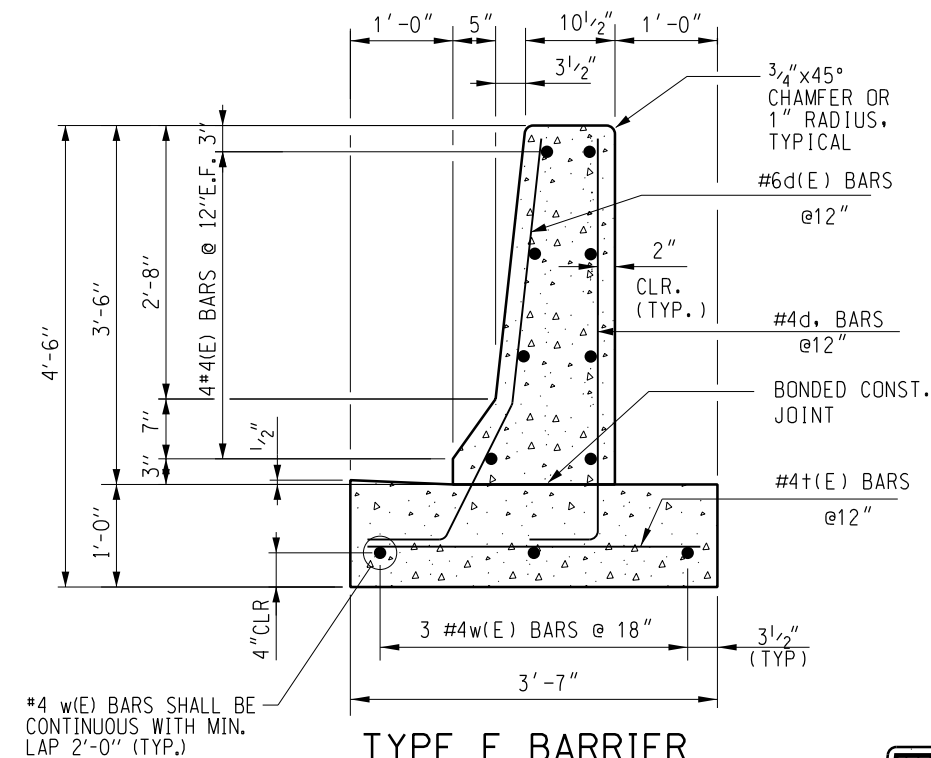
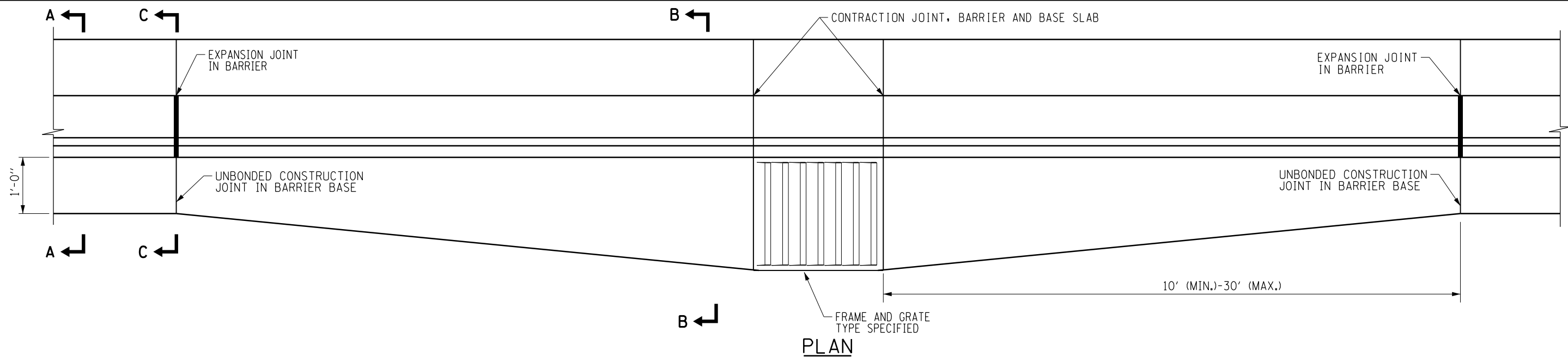

**NOTES:**

1. TOP SHOULDER EDGE OF BARRIER BASE GUTTER SHALL MATCH THE TOP OF SHOULDER ELEVATION.
2. 1" DEEP CONTRACTION JOINTS SHALL BE CONSTRUCTED IN BOTH THE REINFORCED CONCRETE BARRIER WALL AND BASE. CONTRACTION JOINTS SHALL ALSO BE CONSTRUCTED AT BOTH SIDES OF ALL DRAINAGE STRUCTURES. MAXIMUM JOINT SPACING SHALL BE 30 FEET.
3. THE FORMING OF CONTRACTION JOINTS SHALL BE DONE WITH AN APPROVED FINISHING TOOL OR BY SAWING AT THE DISCRETION OF THE ENGINEER SUBJECT TO THE SATISFACTORY CONTROL OF CRACKING.
4. REINFORCING BARS DESIGNATED "E" SHALL BE EPOXY COATED.
5. REINFORCEMENT BENDING DETAILS SHALL BE IN ACCORDANCE WITH THE "MANUAL OF STANDARD PRACTICE FOR DETAILING REINFORCED CONCRETE STRUCTURES", ACI 315, LATEST EDITION.
6. REINFORCEMENT BAR BENDING DIMENSIONS ARE OUT TO OUT.
7. BARRIER SHALL BE USED WITH ALL NEW CONSTRUCTION, OR RECONSTRUCTION OF EXISTING BARRIERS.
8. EXPANSION JOINTS SHALL BE CONSTRUCTED AT DRAINAGE STRUCTURES AS SHOWN AND PLACED ALONG BARRIER WALL AT MAXIMUM JOINT SPACING OF 90 FEET.

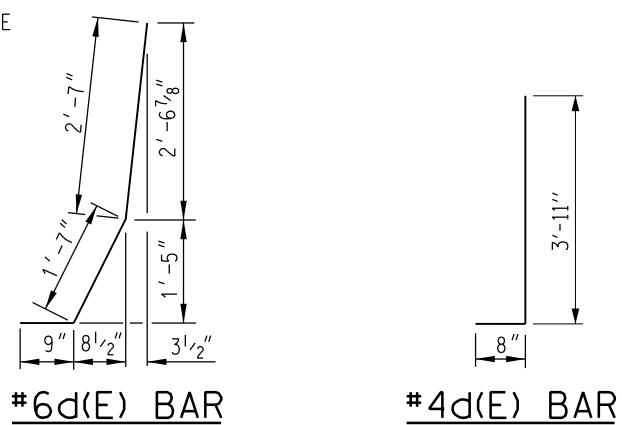
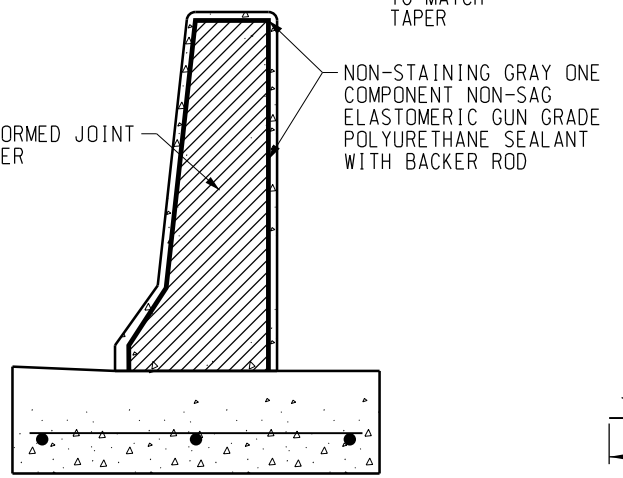
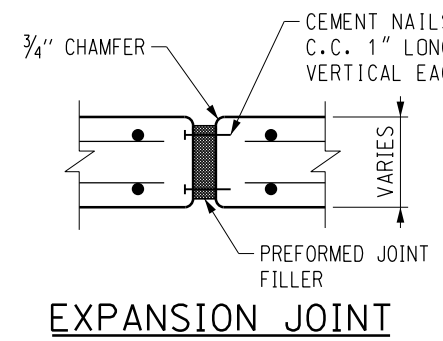

APPROVED *Paul Kovacs* CHIEF ENGINEER DATE 2-7-2012

DATE	REVISIONS
2-7-2012	DELETED TYPE II BARRIER AND REVISED REINFORCEMENT BARS
11-1-2012	GUTTER TRANSITION TAPER DETAIL NEW JOINT DETAIL, REVISED NOTES

**Illinois Tollway**  
Open Roads for a Faster Future

SINGLE FACE REINFORCED CONCRETE BARRIER

STANDARD C3-03

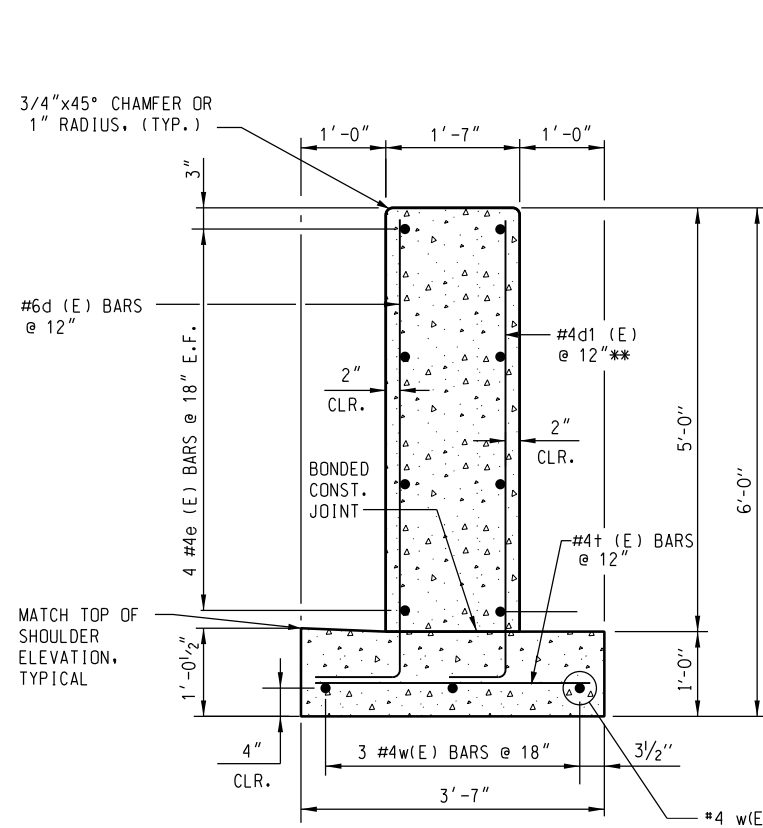

SECTION C-C

#4 w(E) BARS SHALL BE CONTINUOUS WITH MIN. LAP 2'-0" (TYP.)

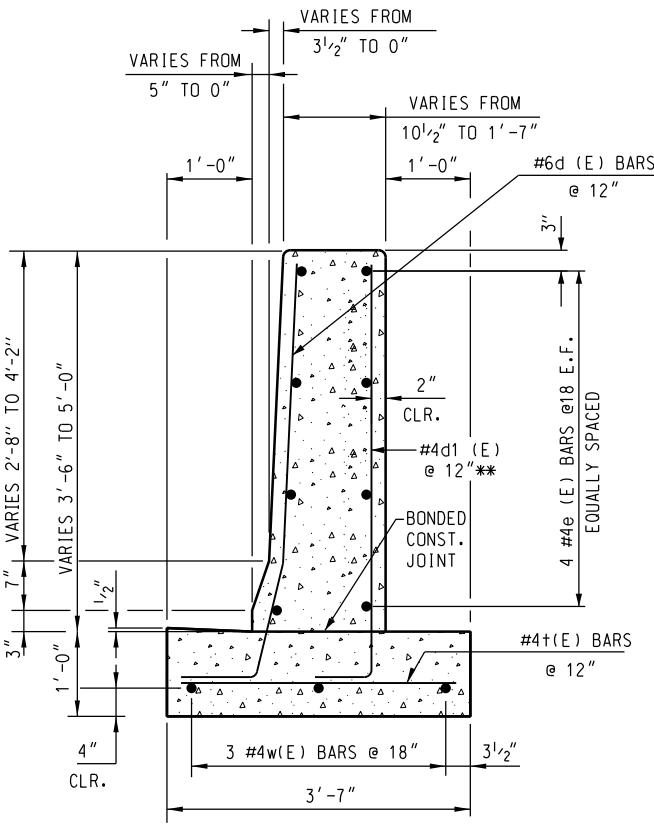

SECTION B-B

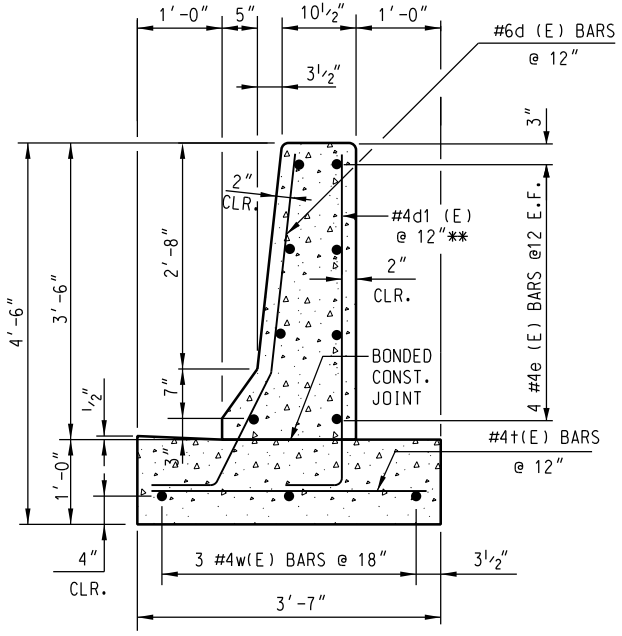

SECTION A-A

\*\* CUT TO FIT IN FIELD  
2" VERTICAL CLR.

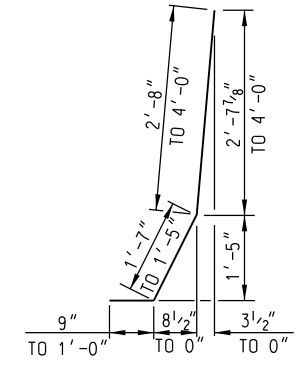

#6d (E) BAR

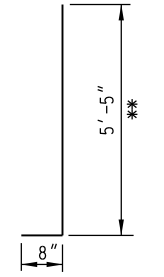

#4d (E) BAR

BENDING DIAGRAMS

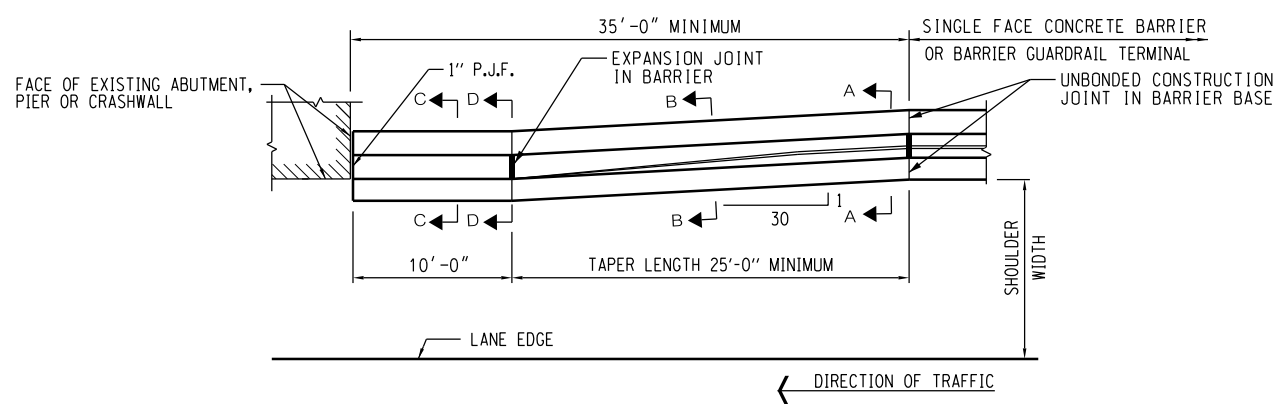

PLAN

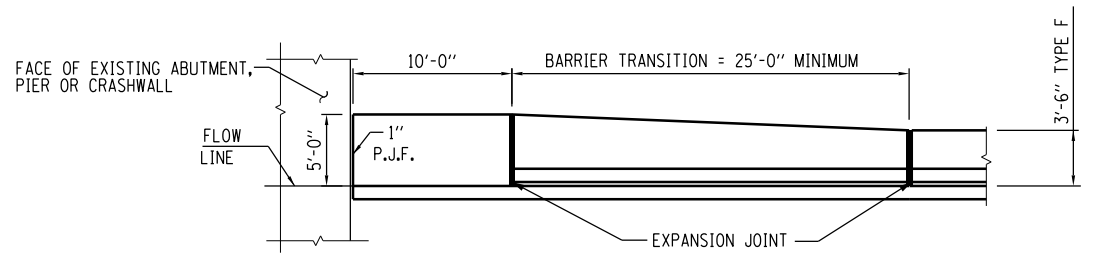

ELEVATION

CONCRETE SHOULDER BARRIER TRANSITION, TYPE F

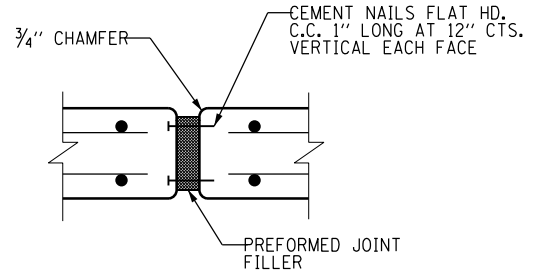

EXPANSION JOINT

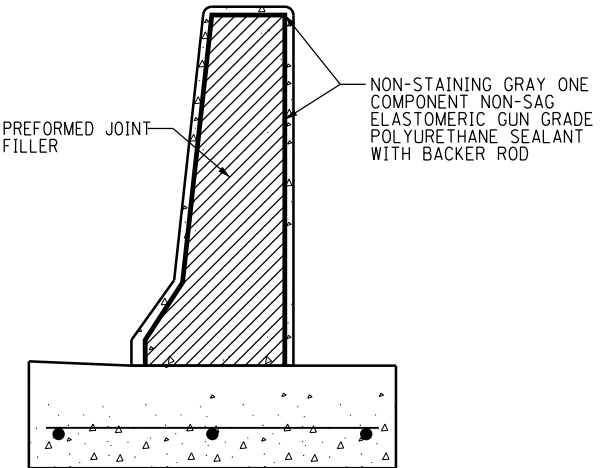

TYPE F BARRIER  
SECTION D-D

NOTES:

1. TAPER LENGTH REQUIRED FOR THE WIDTH TRANSITION WILL BE 25'-0" MINIMUM. INCREASE TAPER RATE AS REQUIRED TO OBTAIN THE LENGTH OF 25'-0".
2. TOP SHOULDER EDGE OF BARRIER BASE GUTTER SHALL MATCH THE TOP OF SHOULDER ELEVATION.
3. 1" DEEP CONTRACTION JOINTS SHALL BE CONSTRUCTED IN BOTH THE REINFORCED CONCRETE BARRIER WALL AND BASE. CONTRACTION JOINTS SHALL ALSO BE CONSTRUCTED AT BOTH SIDES OF ALL DRAINAGE STRUCTURES. MAXIMUM JOINT SPACING SHALL BE 30 FEET.
4. THE FORMING OF CONTRACTION JOINTS SHALL BE DONE WITH AN APPROVED FINISHING TOOL OR BY SAWING AT THE DISCRETION OF THE ENGINEER SUBJECT TO THE SATISFACTORY CONTROL OF CRACKING.
5. REINFORCING BARS DESIGNATED "(E)" SHALL BE EPOXY COATED.
6. REINFORCEMENT BENDING DETAILS SHALL BE IN ACCORDANCE WITH THE "MANUAL OF STANDARD PRACTICES FOR DETAILING REINFORCED CONCRETE STRUCTURES", ACI 315, LATEST EDITION.
7. REINFORCEMENT BAR BENDING DIMENSIONS ARE OUT TO OUT.
8. TYPE F BARRIER SHALL BE USED WITH ALL NEW CONSTRUCTION, OR RECONSTRUCTION OF EXISTING BARRIERS.
9. E.F. DENOTES EACH FACE

APPROVED *Paul Kovacs* CHIEF ENGINEER DATE 2-7-2012

DATE	REVISIONS
2-7-2012	DELETED SHOULDER BARRIER TRANSITION TYPE II, TAPER CHART, REVISED REINFMNT. BARS AND REVISED LENGTH OF VERTICAL FACE BARRIER WALL.
11-1-2012	INCREASED BARRIER TRSITION, NEW JOINT DETAIL

**Illinois Tollway**  
*Open Roads for a Faster Future*

CONCRETE SHOULDER BARRIER TRANSITION

STANDARD C4-03

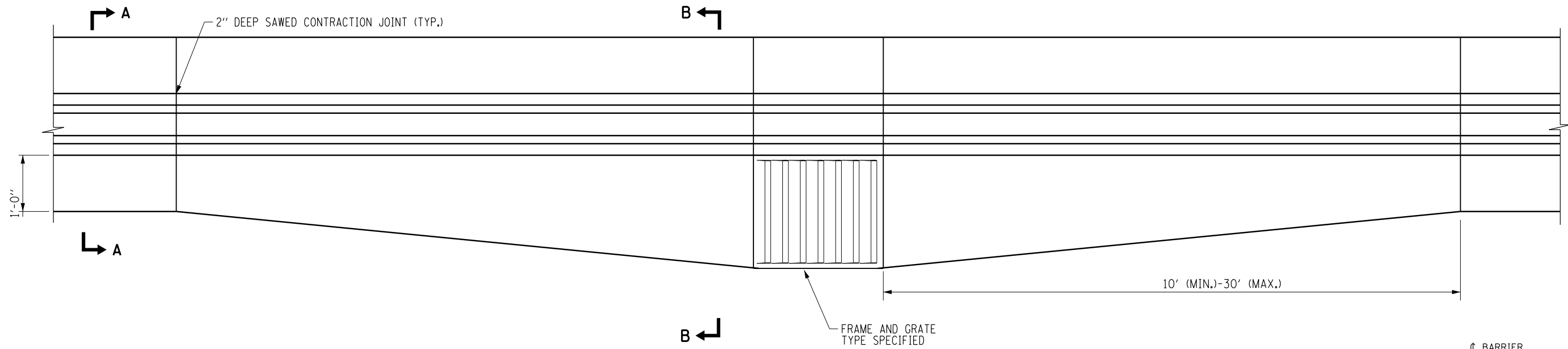

PLAN

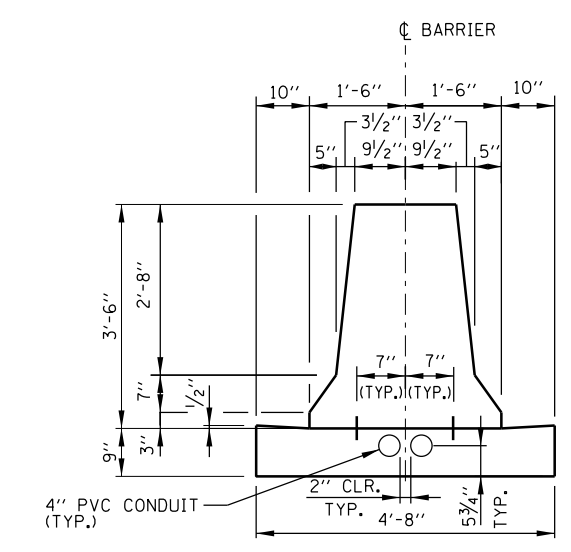

CONCRETE BARRIER, DOUBLE FACE, 42"  
CONCRETE BARRIER BASE  
SECTION A-A

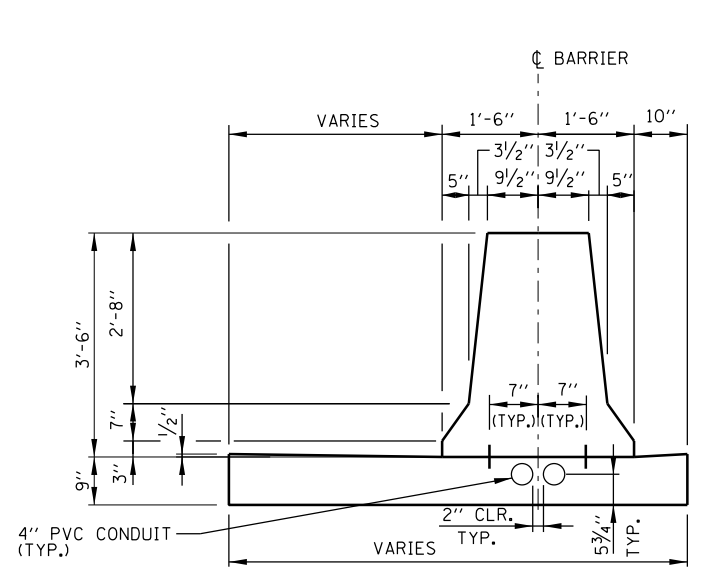

CONCRETE BARRIER, DOUBLE FACE, 42"  
CONCRETE BARRIER BASE  
SECTION B-B

CONCRETE BARRIER, DOUBLE FACE, VARIABLE  
HEIGHT CONCRETE BARRIER BASE, VARIABLE HEIGHT

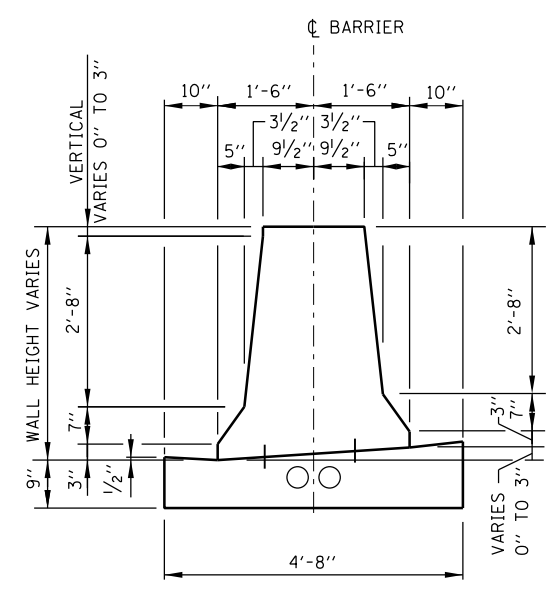

DETAIL A

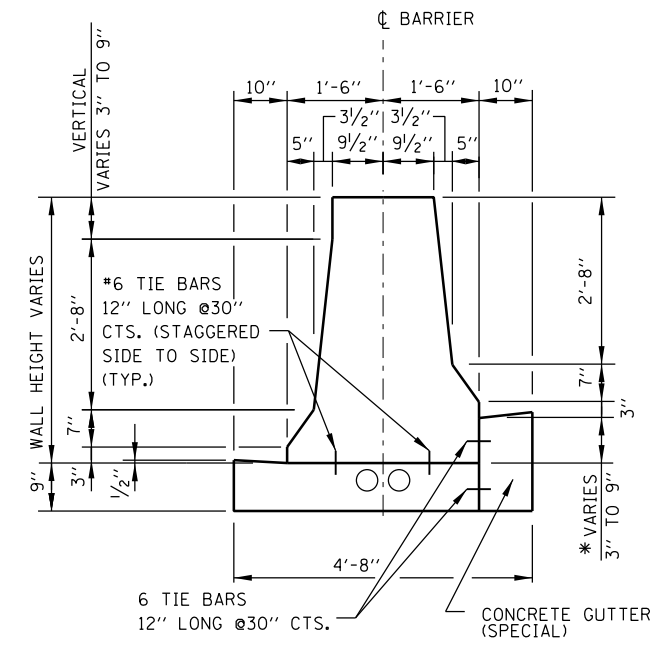

DETAIL B

\* WHEN 6" OR GREATER ADD TOP TIE BAR.

NOTES:

- 2" DEEP CONTRACTION JOINTS SHALL BE CONSTRUCTED IN THE CONCRETE BARRIER WALL AND IN THE CONCRETE BARRIER BASE. CONTRACTION JOINTS SHALL ALSO BE CONSTRUCTED AT BOTH SIDES OF ALL DRAINAGE STRUCTURES. MAXIMUM JOINT SPACING SHALL BE 30'.
- THE FORMING OF CONTRACTION JOINTS SHALL BE DONE WITH AN APPROVED FINISHING TOOL OR BY SAWING AT THE DISCRETION OF THE ENGINEER SUBJECT TO THE SATISFACTORY CONTROL OF CRACKING.
- GUTTER PROFILE IN THE VICINITY OF SAG VERTICAL CURVES, ALONG FLAT GRADES AND AT THE MEETING OF PROPOSED AND EXISTING GUTTER, SHALL BE CAREFULLY CONTROLLED AND FIELD ADJUSTED IF NECESSARY TO ENSURE POSITIVE DRAINAGE AND AVOID PONDING.
- IN AREAS OF RELATIVELY FLAT LONGITUDINAL PROFILE GRADES, THE 3" VERTICAL DIMENSION AT THE BOTTOM OF THE BARRIER CAN VARY FROM 2" TO 3 1/4" TO CREATE AN ACCEPTABLE LONGITUDINAL GRADE IN THE GUTTER.
- TIE BARS ARE INCIDENTAL TO THE VARIOUS BARRIER & GUTTER ITEMS AND SHALL BE EPOXY COATED.
- TWO CONDUITS SHALL BE INSTALLED IN THE BARRIER BASE WHETHER ELECTRICAL OR ITS ELEMENTS ARE INCLUDED FOR FUTURE USE.
- WHEN VARIABLE HEIGHT VERTICAL DIFFERENTIAL EXCEEDS 9" SEE CONSTRUCTION PLANS FOR DETAILS.

APPROVED *Paul Kovacs* CHIEF ENGINEER DATE 2-7-2012

DATE	REVISIONS
2-7-2012	ADDED CONDUITS TO BARRIER BASE.
11-1-2012	ADDED GUTTER TRANSITION TAPER DETAIL AND NEW JOINT DETAIL

**Illinois Tollway**  
Open Roads for a Faster Future

CONCRETE BARRIER BASE AND  
CONCRETE BARRIER, DOUBLE FACE,  
42" AND VARIABLE HEIGHT

STANDARD C5-02

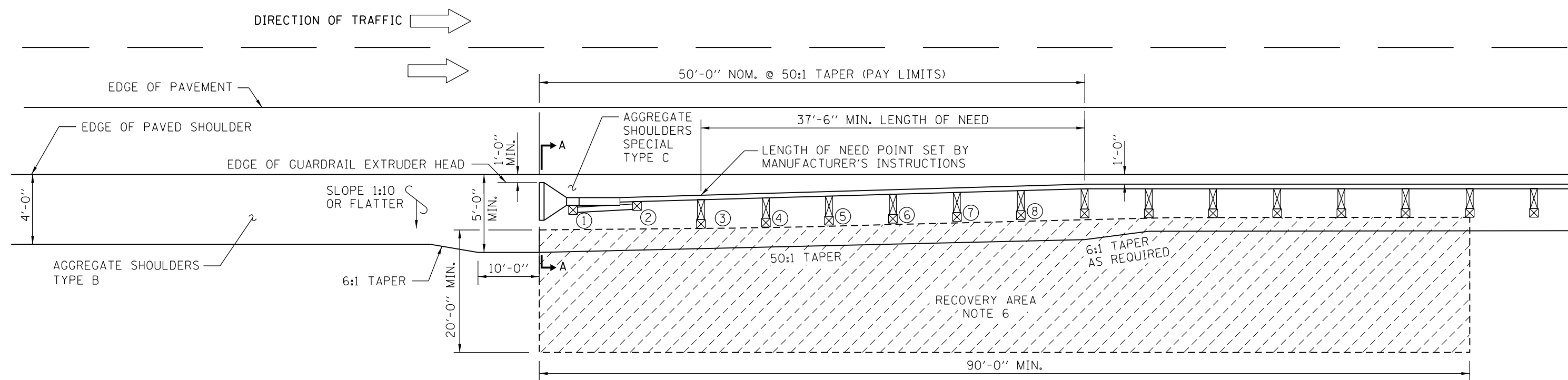

**SHOULDER WIDENING TRANSITION-WITHOUT GUTTER  
FOR TRAFFIC BARRIER TERMINAL TYPE T1 (SPECIAL)**

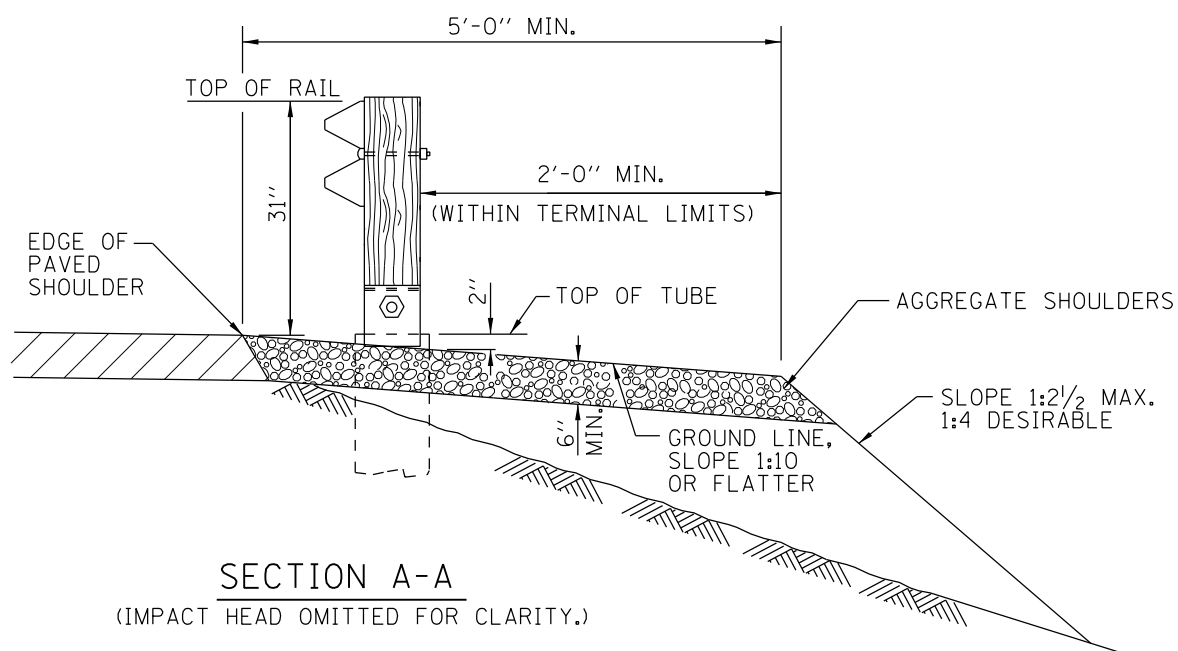

**SECTION A-A**

(IMPACT HEAD OMITTED FOR CLARITY.)

**NOTE FOR INSTALLATION ON TANGENT ROADWAY:**

TRAFFIC BARRIER TERMINAL SHALL BE INSTALLED AT A 50:1 TAPER MEASURED FROM EDGE OF TRAVELED WAY.

**NOTE FOR INSTALLATION ON CURVED ROADWAY:**

THE EDGE OF THE TERMINAL EXTRUDER HEAD SHALL BE OFFSET A DISTANCE FROM A POINT ON THE BACK OF THE CURVED EDGE OF PAVED SHOULDER AS SHOWN IN TABLE 1.

**GENERAL NOTES:**

1. ALL SLOPE RATIOS ARE EXPRESSED AS UNITS OF VERTICAL DISPLACEMENT TO UNITS OF HORIZONTAL DISPLACEMENT (V:H).
2. THE TYPE T1 (SPECIAL) TERMINAL IS THE UPSTREAM END SECTION OF A GALVANIZED STEEL PLATE BEAM GUARDRAIL BARRIER SYSTEM.
3. REFERENCE STANDARD B28 FOR GUTTER TRANSITION AT TRAFFIC BARRIER TERMINAL TYPE T1 (SPECIAL).
4. UNDER NO CIRCUMSTANCES SHALL AN EXISTING TERMINAL, THAT WAS DESIGNED USING A PREVIOUS STANDARD, BE ATTACHED TO OR MODIFIED IN ANYWAY FROM ITS ORIGINAL DESIGN. IF ANY MODIFICATION IS REQUIRED AND A PROPER BARRIER WARRANT HAS BEEN COMPLETED, THE ENTIRE BARRIER INSTALLATION SHALL BE COMPLETELY REMOVED AND REPLACED WITH A NEW SYSTEM THAT CONFORMS TO THE CURRENT STANDARD.
5. TRAFFIC BARRIER TERMINAL SHALL BE IN ACCORDANCE WITH THE MANUFACTURER'S DETAILS AND SPECIFICATIONS.
6. NO ROADSIDE OBSTRUCTION OF ANY TYPE-FIXED OR BREAKAWAY, EITHER TEMPORARY OR PERMANENT SHALL BE ALLOWED WITHIN THIS RECOVERY AREA.
7. NO CURVED W-BEAM SECTIONS ARE PERMITTED WITHIN THE TERMINAL PAY LIMITS. THE TRAFFIC BARRIER TERMINAL TYPE T1 (SPECIAL) SHALL BE LAID OUT IN A STRAIGHT LINE.
8. TERMINAL POSTS SHALL NOT BE INSTALLED IN CONCRETE OR HMA. WHEN NECESSARY USE LEAVE-OUT DETAIL SHOWN ON STANDARD C1.
9. THE TERMINAL SYSTEM HAS BEEN PERFORMANCE-TESTED FOR CRASHWORTHINESS UNDER PROCEDURES DEFINED IN THE NATIONAL COOPERATIVE HIGHWAY RESEARCH REPORT (NCHRP) REPORT 350. NO MODIFICATION TO THIS STANDARD DRAWING SHALL BE PERMITTED.



REVISIONS	
3-1-2010	ADDED OBSTRUCTION FREE ZONES. REVISED NOTES.
1-1-2011	ADDED NEW SHEET, SHOULDER WIDENING WITH GUTTER. REVISED NOTES, ADDED CURVED ROADWAY TERMINAL PLACEMENT.
2-7-2012	REVISED SLOPE NOTE.
11-1-2012	MODIFIED AGGEGATE SHOULDERS

SHOULDER WIDENING FOR TRAFFIC BARRIER TERMINAL TYPE T1 (SPECIAL)

STANDARD C6-04

*Paul Kovacs*  
APPROVED ..... CHIEF ENGINEER ..... DATE 7-1-2009 .....

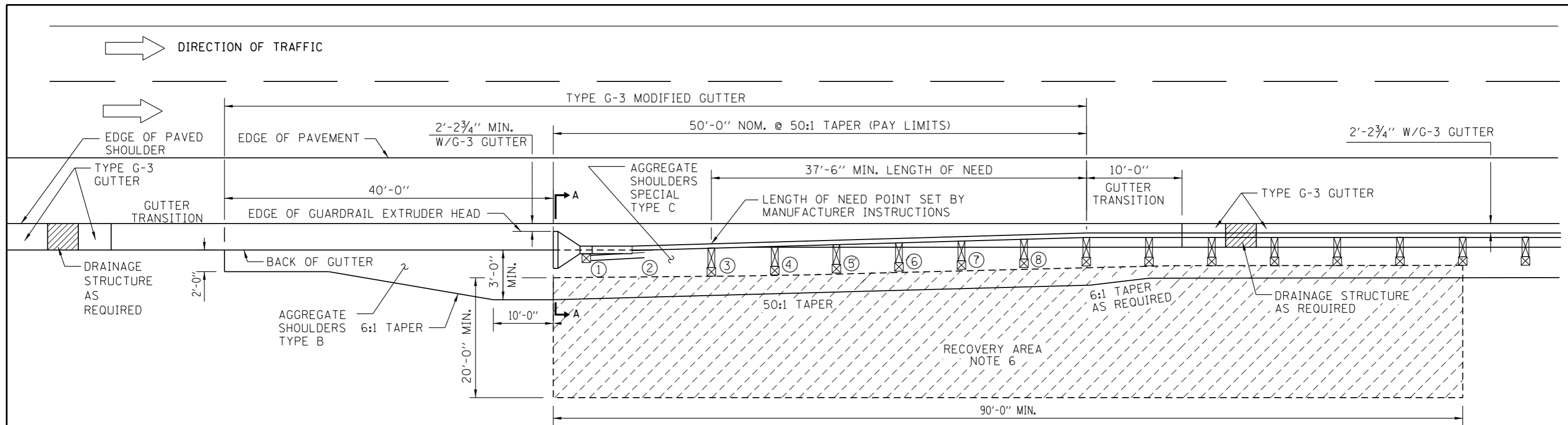

SHOULDER WIDENING TRANSITION-WITH GUTTER, TYPE G-3 FOR TRAFFIC BARRIER TERMINAL TYPE T1 (SPECIAL)

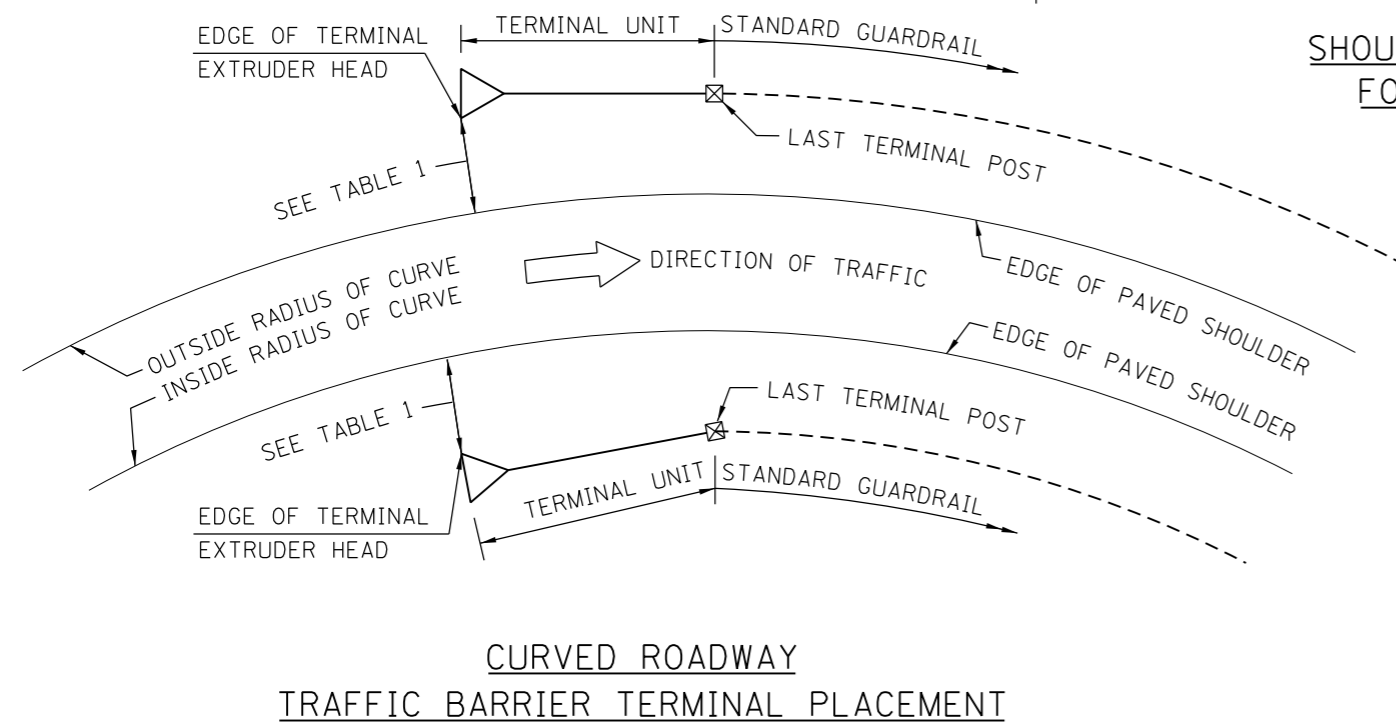

CURVED ROADWAY TRAFFIC BARRIER TERMINAL PLACEMENT

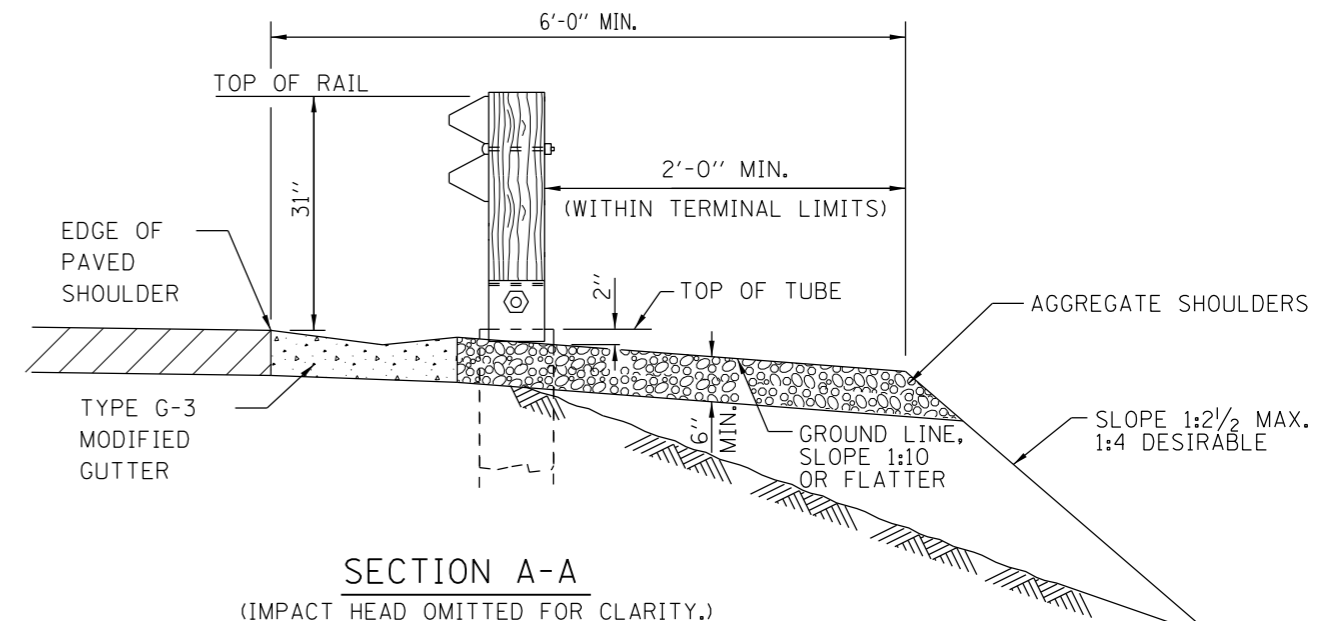

SECTION A-A (IMPACT HEAD OMITTED FOR CLARITY.)

NOTE: SEE SHEET 1 OF THIS SERIES FOR NOTES.

TABLE 1		
LATERAL OFFSET DIMENSION TO EDGE OF TERMINAL EXTRUDER HEAD		
	INSIDE RADIUS OF CURVE	OUTSIDE RADIUS OF CURVE
NO GUTTER	1'-0"	1'-0" MIN. *
TYPE G-2 GUTTER	1'-2 3/4"	1'-2 3/4" MIN. *
TYPE G-3 GUTTER	2'-2 3/4"	2'-2 3/4" MIN. *

(\* ) OFFSET DISTANCE WILL VARY BASED ON RADIUS OF HORIZONTAL CURVE AND THE TERMINAL BEING INSTALLED IN A STRAIGHT LINE.



SHOULDER WIDENING FOR TRAFFIC BARRIER TERMINAL TYPE T1 (SPECIAL)

STANDARD C6-04

APPROVED *Paul Kovacs* CHIEF ENGINEER DATE 7-1-2009

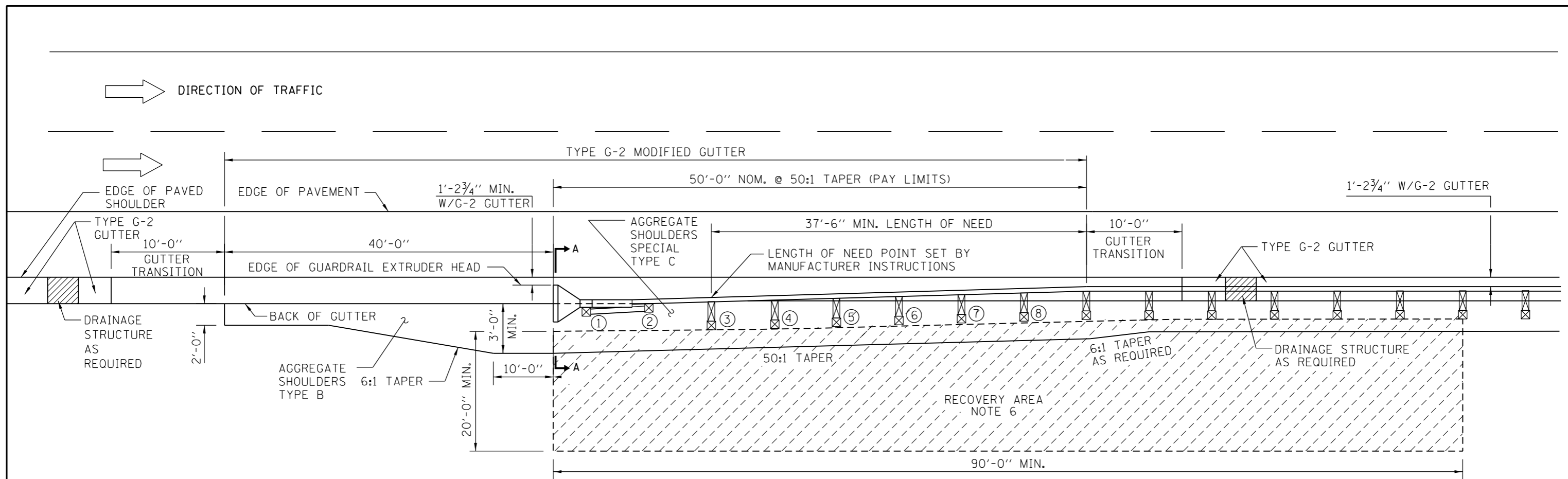

**SHOULDER WIDENING TRANSITION-WITH GUTTER, TYPE G-2  
FOR TRAFFIC BARRIER TERMINAL TYPE T1 (SPECIAL)**

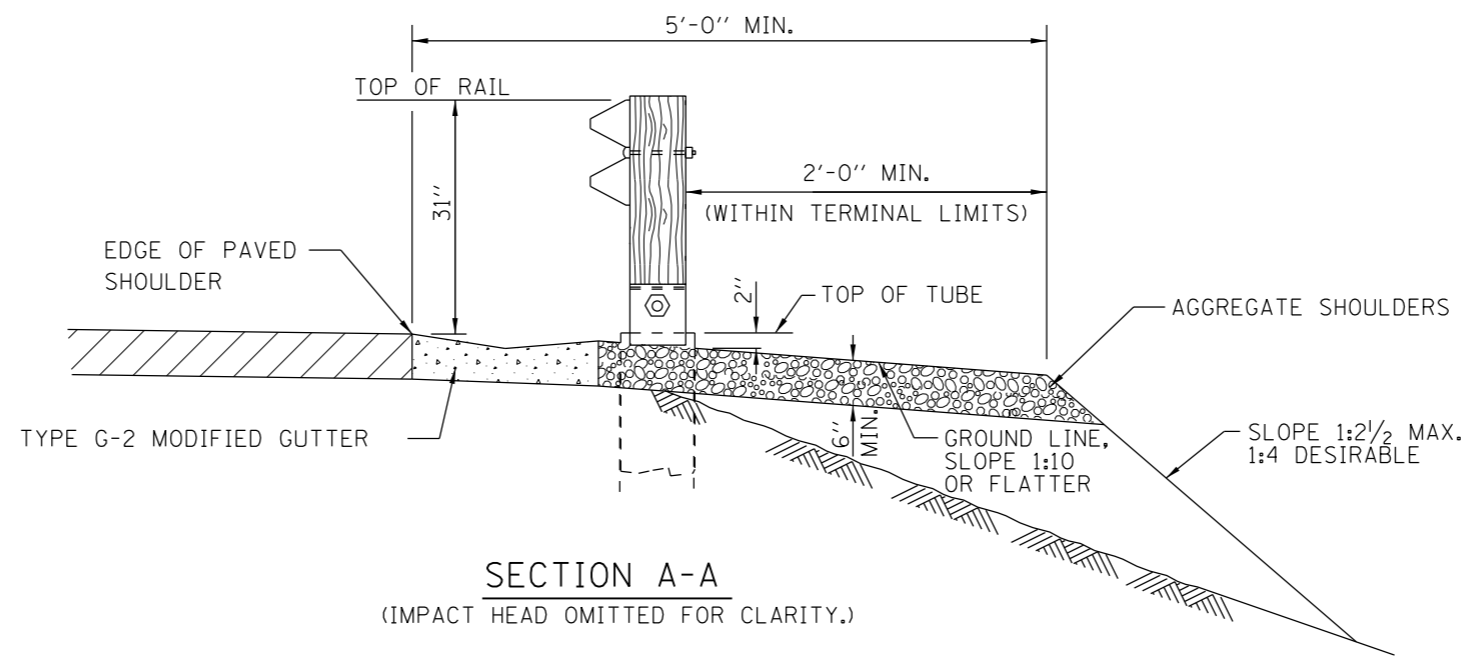

**NOTE:**  
SEE SHEET 1 OF THIS SERIES FOR NOTES.

SHEET 3 OF 3



SHOULDER WIDENING FOR  
TRAFFIC BARRIER TERMINAL  
TYPE T1 (SPECIAL)

STANDARD C6-04

*Paul Kovacs*  
APPROVED ..... CHIEF ENGINEER ..... DATE 7-1-2009 .....

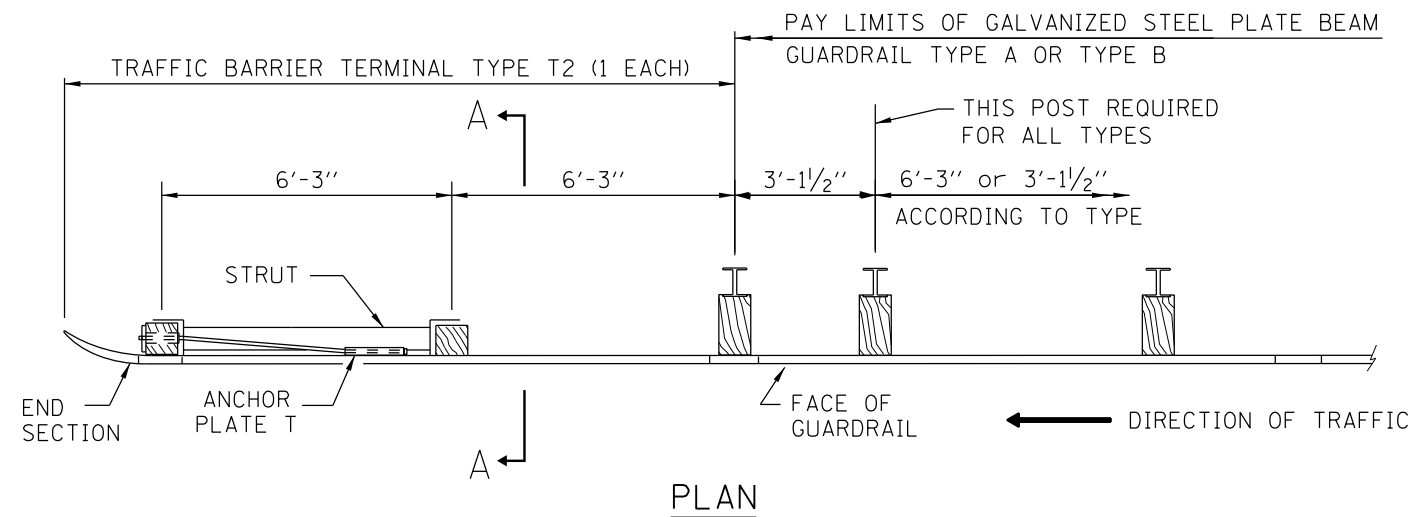

PLAN

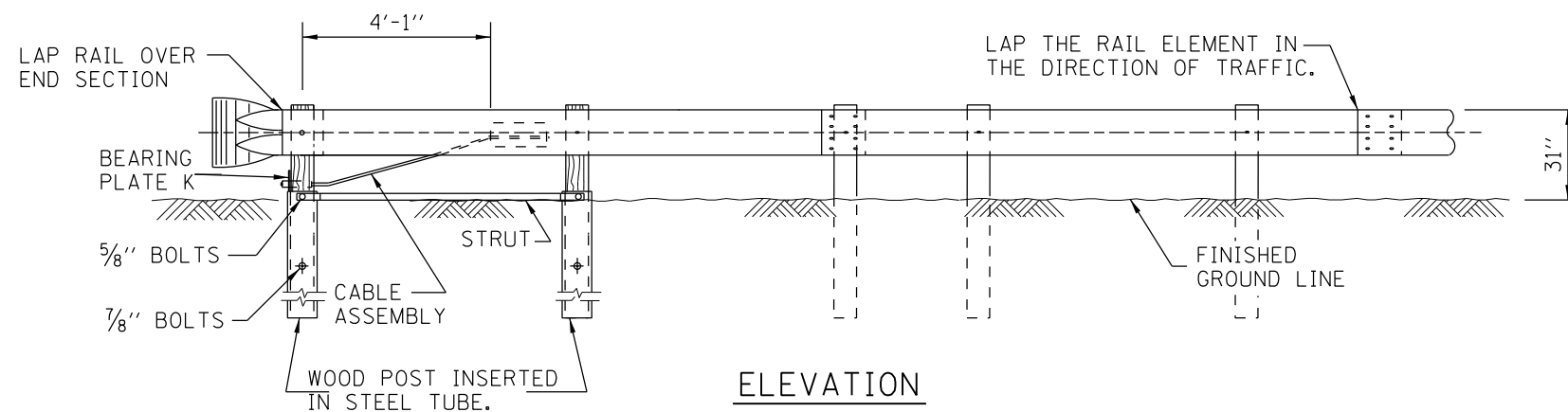

ELEVATION

TRAFFIC BARRIER TERMINAL TYPE T2-WITHOUT GUTTER

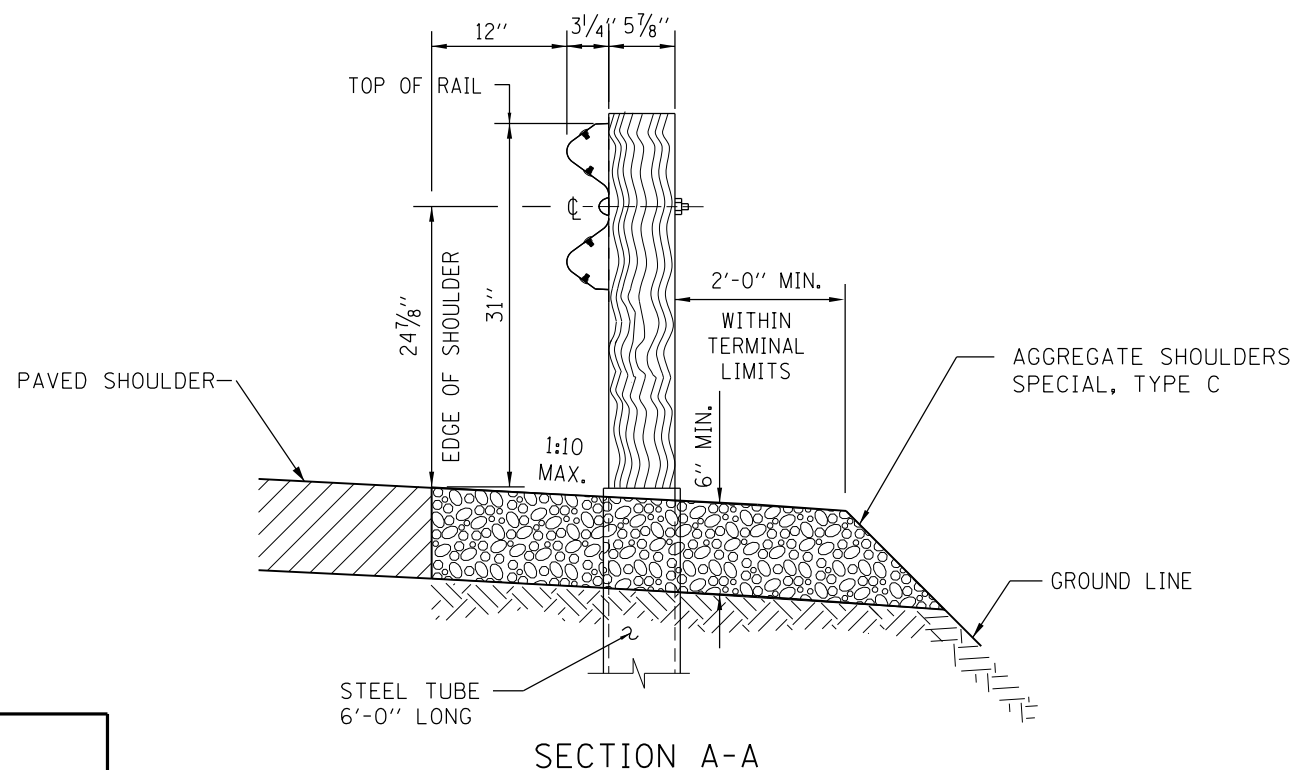

SECTION A-A

NOTES:

1. SEE STANDARD C1 FOR DETAILS OF GUARDRAIL NOT SHOWN.
2. THE BEARING PLATE K SHALL BE HELD IN POSITION BY TWO 8D NAILS DRIVEN INTO THE POST AND BENT OVER THE TOP OF THE PLATE.
3. THE TYPE T2 TERMINAL IS TYPICALLY UTILIZED FOR THE DEPARTING END SECTION OF A GALVANIZED STEEL PLATE BEAM GUARDRAIL BARRIER SYSTEM.
4. UNDER NO CIRCUMSTANCES SHALL AN EXISTING TERMINAL, THAT WAS DESIGNED USING A PREVIOUS STANDARD, BE ATTACHED TO OR MODIFIED IN ANYWAY FROM ITS ORIGINAL DESIGN. IF ANY MODIFICATION IS REQUIRED AND A PROPER BARRIER WARRANT HAS BEEN COMPLETED, THE ENTIRE BARRIER INSTALLATION SHALL BE COMPLETELY REMOVED AND REPLACED WITH A NEW SYSTEM THAT CONFORMS TO THE CURRENT STANDARD.
5. TRAFFIC BARRIER TERMINAL SHALL BE IN ACCORDANCE WITH THE MANUFACTURER'S DETAILS AND SPECIFICATIONS.
6. TERMINAL POSTS SHALL NOT BE INSTALLED IN CONCRETE OR HMA PAVEMENT. WHEN NECESSARY USE LEAVE-OUT DETAIL PER STANDARD C1.
7. WHERE GUTTERS SUCH AS TYPE G-2 ,G-3 ARE REQUIRED IN FRONT OF THE GUARDRAIL, THE POSTS SHALL BE LOCATED 6" BEHIND THE GUTTER, OR AS OTHERWISE DETAILED IN THE PLANS. THE OFFSET FROM THE EDGE OF SHOULDER TO THE FACE OF THE GUARDRAIL SHALL BE AS SHOWN ON STANDARD B28.

REVISIONS	
1-1-2011	REMOVED WOOD BLOCKOUT, SECTION A-A, SHEET 1, REVISED STEEL TUBE LENGTH
2-7-2012	REVISED DIMENSIONS OF BEARING PLATE, POST, CABLE STRUT AND TUBE, AND NOTES
11-1-2012	MODIFIED AGGREGATE SHOULDERS, REVISED WOOD POST DIMENSION

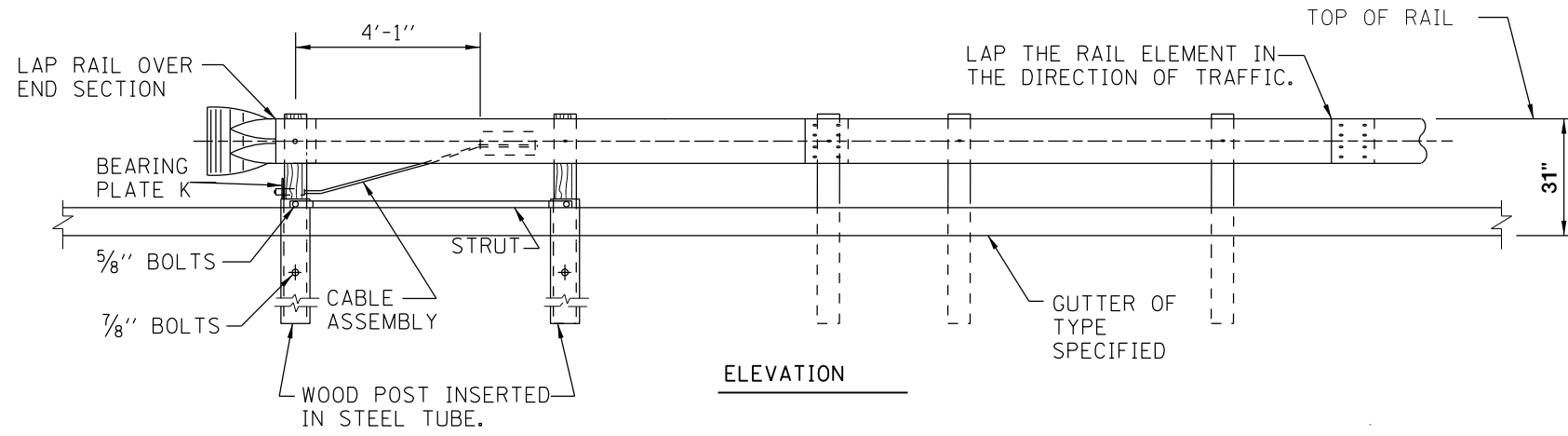
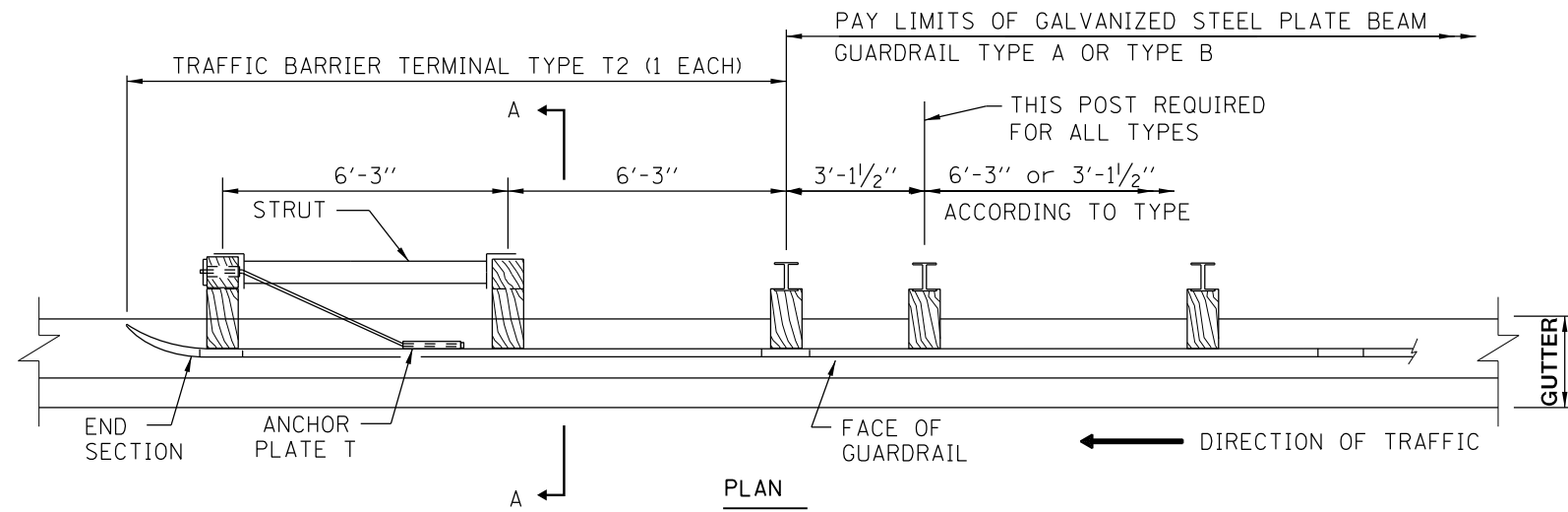

TRAFFIC BARRIER TERMINAL TYPE T2-WITH GUTTER

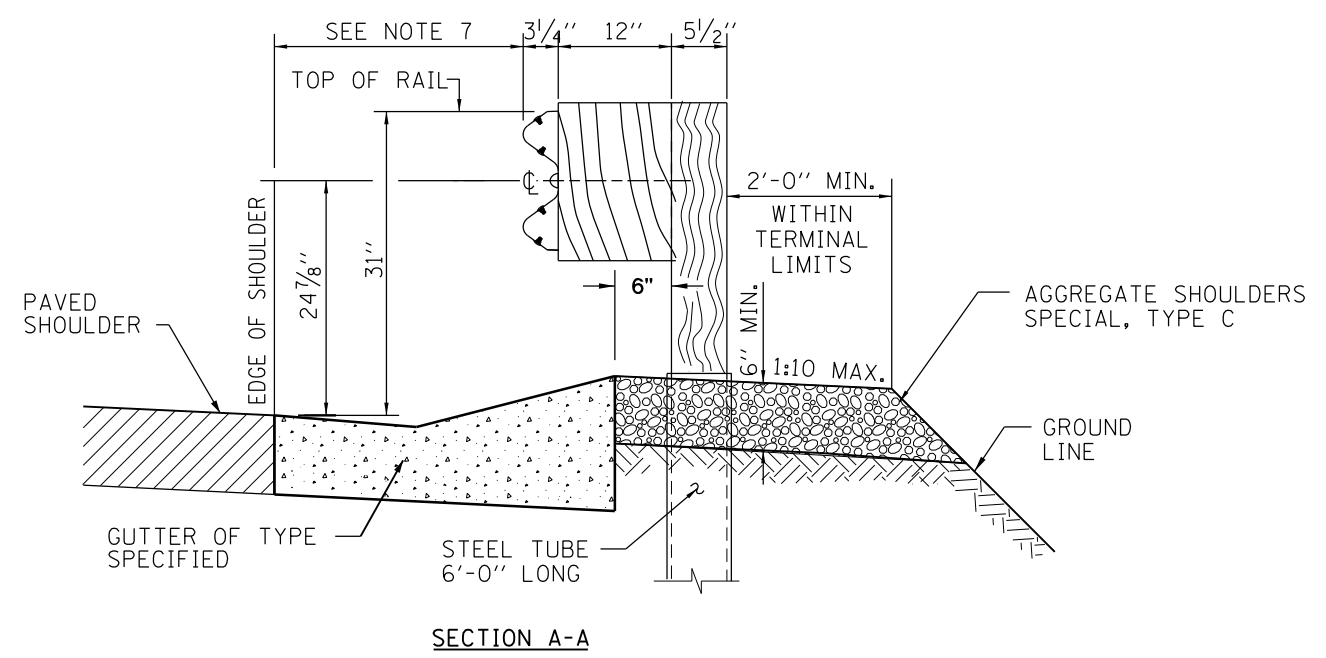

SECTION A-A

**NOTE:**  
SEE SHEET 1 OF THIS SERIES FOR NOTES.

*Paul Kovacs*  
APPROVED ..... CHIEF ENGINEER ..... DATE 7-1-2009 .....

**Illinois Tollway**  
*Open Roads for a Faster Future*

TRAFFIC BARRIER  
TERMINAL, TYPE T2

STANDARD C7-04



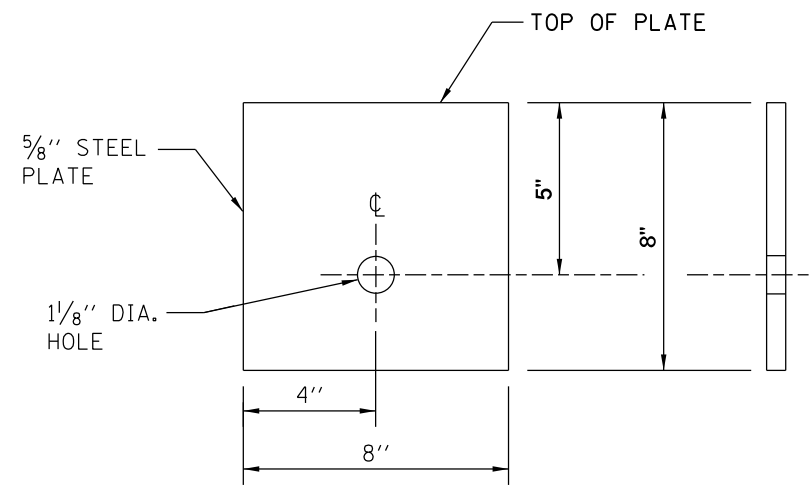

**BEARING PLATE K**

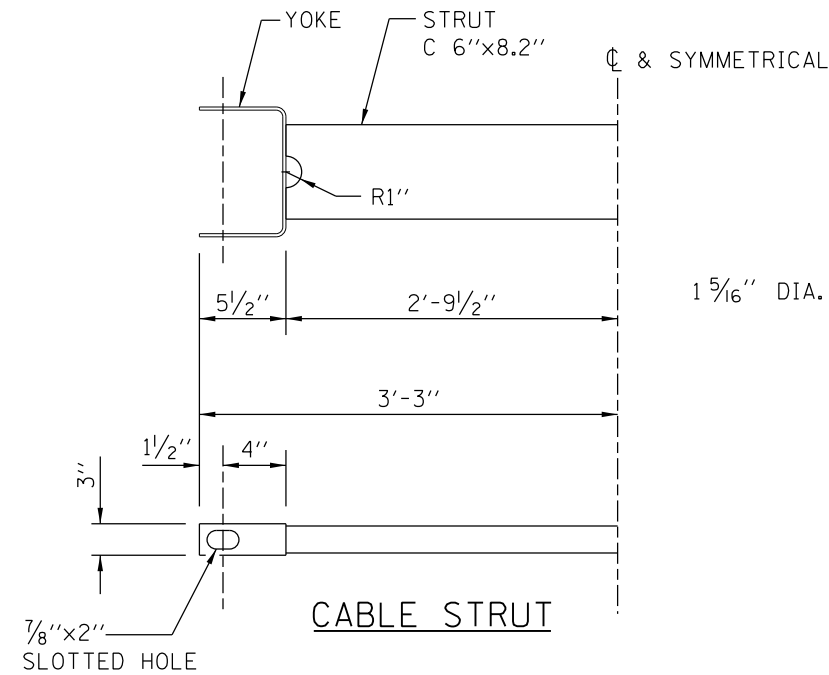

**CABLE STRUT**

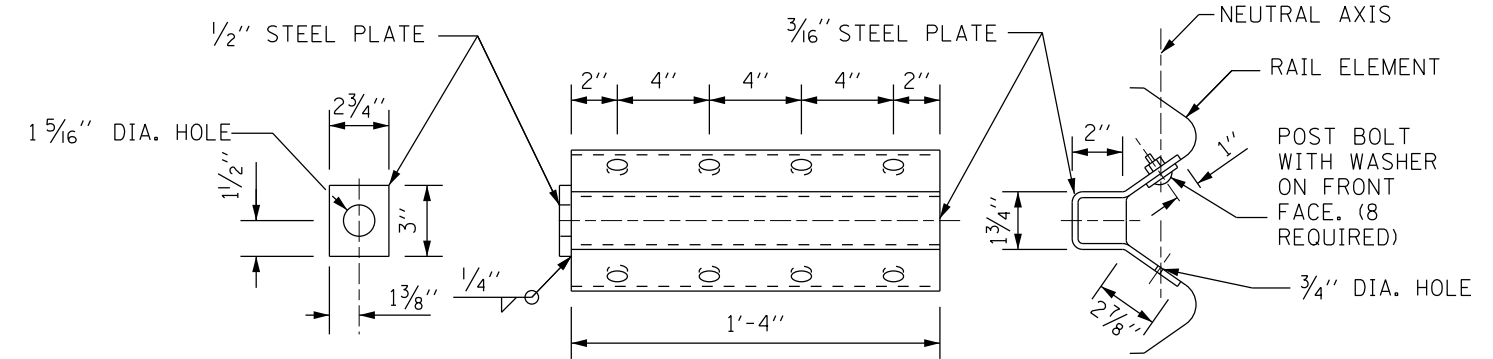

**NOTE:**

ANCHOR PLATE T SHALL BE USED TO ATTACH CABLE ASSEMBLY TO GUARDRAIL WHEN REQUIRED ON TRAFFIC BARRIER TERMINALS.

**ANCHOR PLATE T DETAILS**

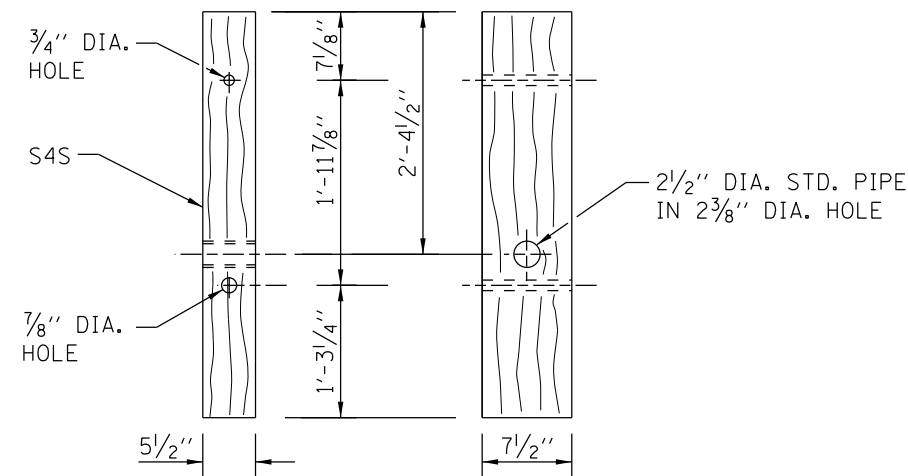

**WOOD POST**

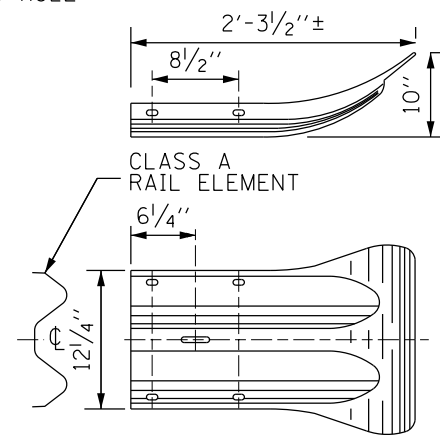

**END SECTION**

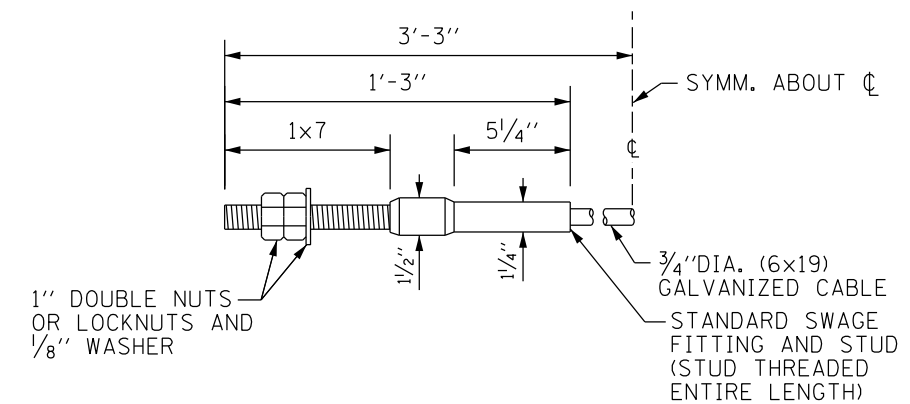

**CABLE ASSEMBLY**  
(40,000 LBS.) MIN. BREAKING STRENGTH)  
TIGHTEN TO TAUT TENSION.

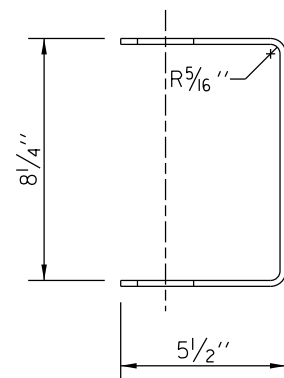

**YOKE**  
3/16" THICK STEEL

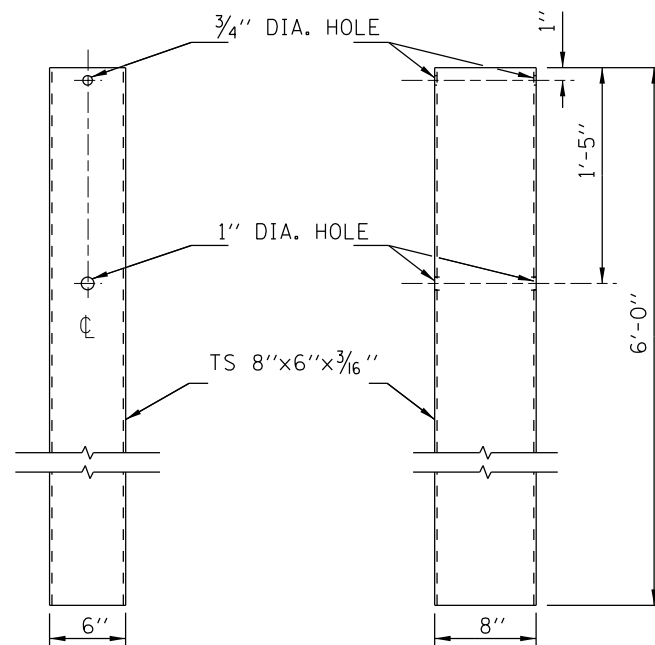

**FRONT**

**SIDE**

**STEEL TUBE**

**NOTE:**

SEE SHEET 1 OF THIS SERIES FOR NOTES.

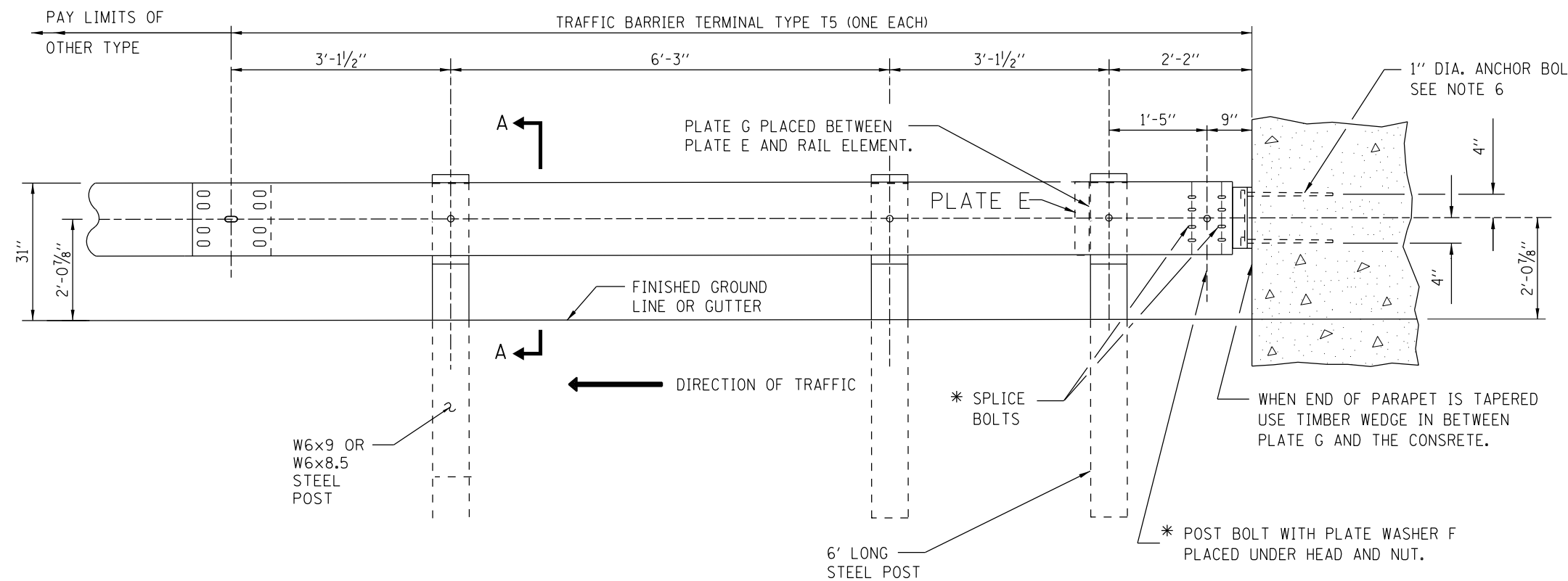

\* WHEN AN EXPANSION JOINT EXISTS BELOW THE CONNECTOR, BOLTS SHALL BE PROVIDED WITH A LOCKNUT OR DOUBLE NUTS AND SHALL BE TIGHTENED ONLY TO A POINT THAT WILL ALLOW PLATE G TO BE FREE TO MOVE.

**NOTES:**

1. INSTALL PLATE WASHER D SO THE 1" PROJECTION FILLS THE REMAINDER OF THE SLOTTED HOLES IN THE 1" END PLATE ON PLATE G AFTER THE 1" DIA BOLTS ARE IN PLACE.
2. SEE STANDARD C1 FOR DETAILS OF GUARDRAIL NOT SHOWN.
3. THE TYPE T5 TERMINAL IS TYPICALLY UTILIZED TO CONNECT GALVANIZED STEEL PLATE BEAM GUARDRAIL TO THE CONCRETE BRIDGE PARAPET AT THE DEPARTING END OF A NEW BRIDGE.
4. UNDER NO CIRCUMSTANCES SHALL AN EXISTING TERMINAL, THAT WAS DESIGNED USING A PREVIOUS STANDARD, BE ATTACHED TO OR MODIFIED IN ANYWAY FROM ITS ORIGINAL DESIGN. IF ANY MODIFICATION IS REQUIRED AND A PROPER BARRIER WARRANT HAS BEEN COMPLETED, THE ENTIRE BARRIER INSTALLATION SHALL BE COMPLETELY REMOVED AND REPLACED WITH A NEW SYSTEM THAT CONFORMS TO THE CURRENT STANDARD.
5. TRAFFIC BARRIER TERMINAL SHALL BE IN ACCORDANCE WITH THE MANUFACTURER'S DETAILS AND SPECIFICATIONS.
6. 1" DIA. ANCHOR BOLT, 3'-6" LENGTH, SHALL BE CAST IN PLACE AN EMBEDDED LENGTH 3'-2" IN THE CONCRETE PARAPET. DRILLING FOR PLACEMENT OF THIS ANCHORAGE IS NOT PERMITTED.
7. TERMINAL POSTS SHALL NOT BE INSTALLED IN CONCRETE OR HMA PAVEMENT. WHEN NECESSARY, USE LEAVE-OUT DETAIL PER STANDARD C1.
8. REFERENCE STANDARD B2 FOR GUTTER TRANSITION AT TRAFFIC BARRIER TERMINAL TYPE T5.
9. TERMINAL BARRIER CLEARANCE DISTANCE SHALL CONFORM WITH TABLE 2 ON STANDARD C1.

**TYPE T5 - CONCRETE BRIDGE PARAPET**

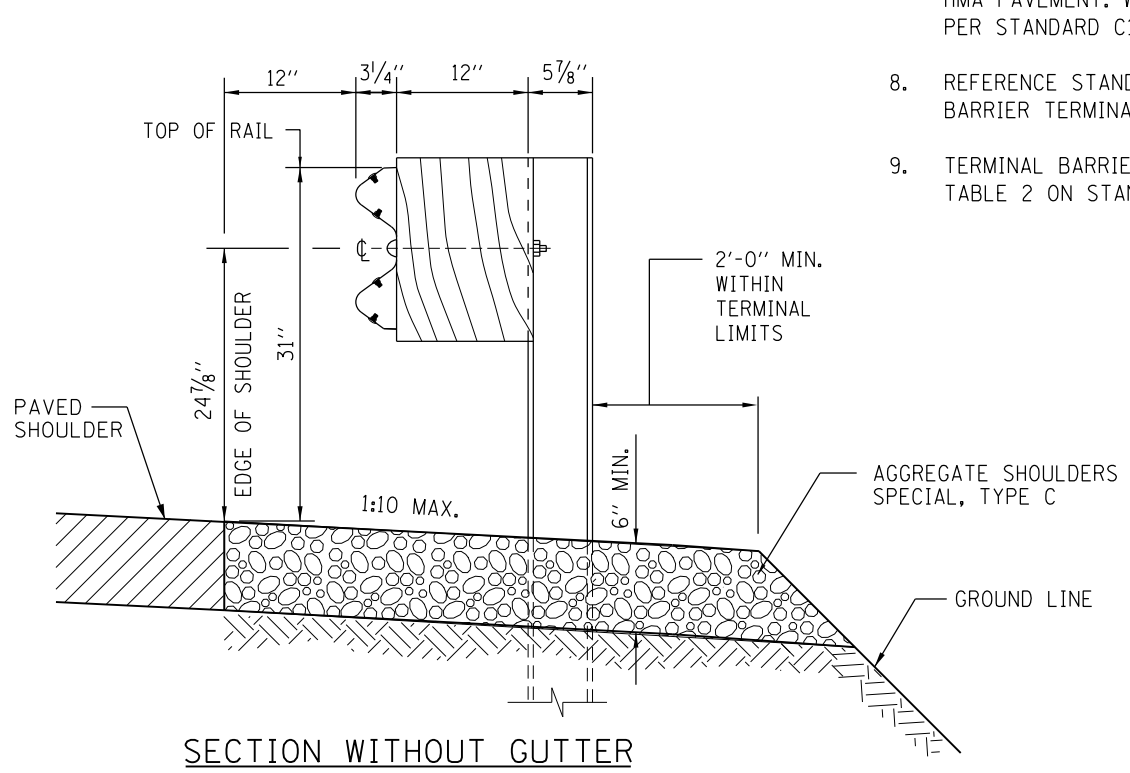
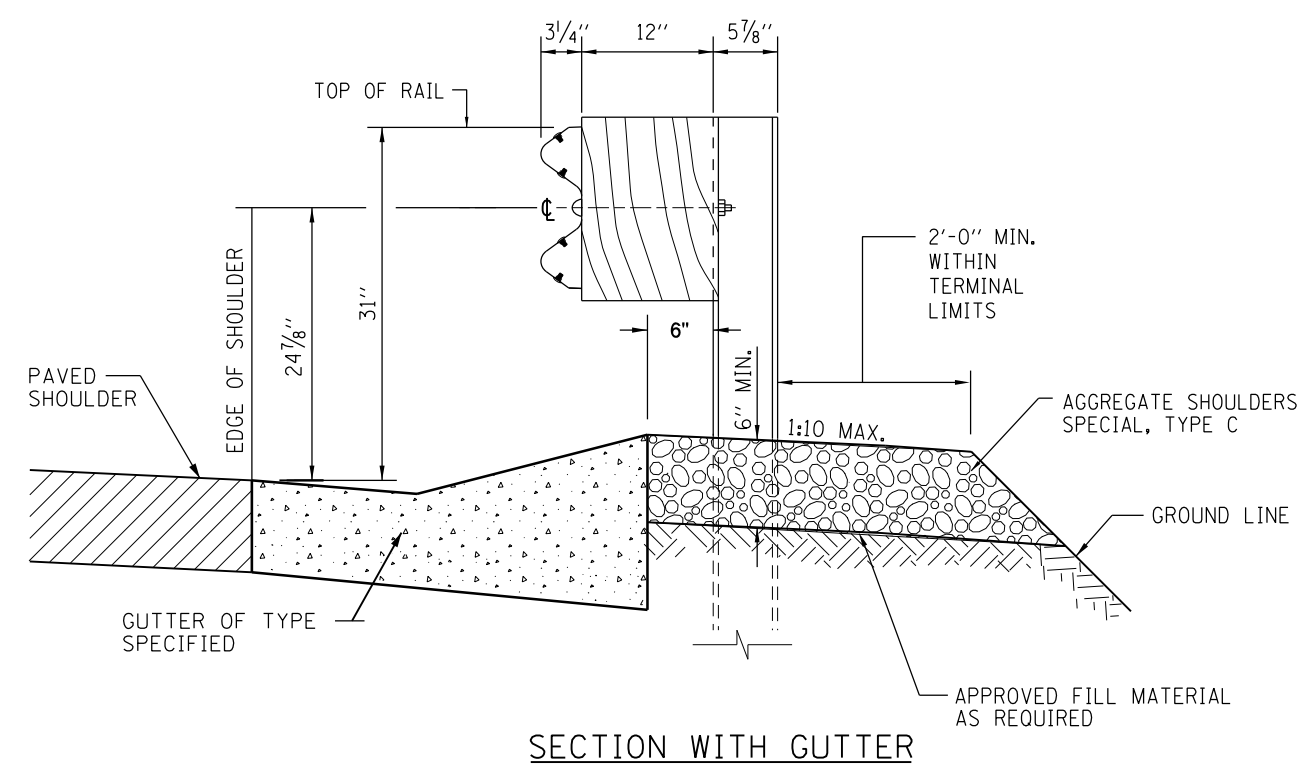

SECTION WITH GUTTER

SECTION WITHOUT GUTTER

**SECTION A-A**



APPROVED *Paul Kovacs* CHIEF ENGINEER DATE 7-1-2009

REVISIONS	
3-1-2010	ADDED SECTION A-A, ADDED NOTES
1-1-2011	REVISED NOTES
2-7-2012	REVISED NOTES
11-1-2012	MODIFIED AGGREGATE SHOULDER

TRAFFIC BARRIER TERMINAL, TYPE T5  
STANDARD C8-04

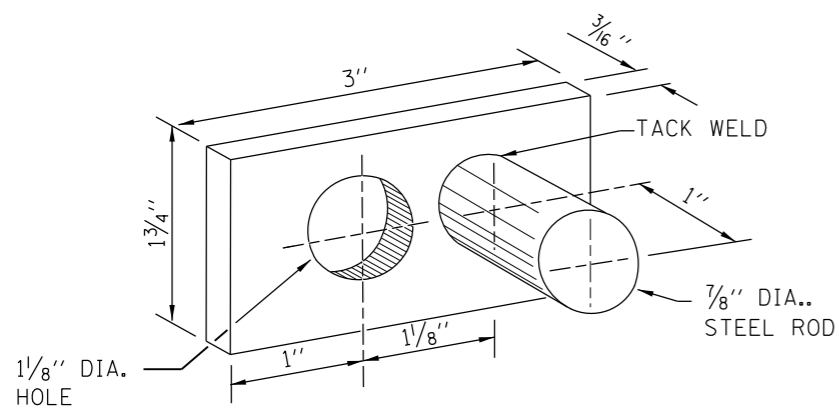
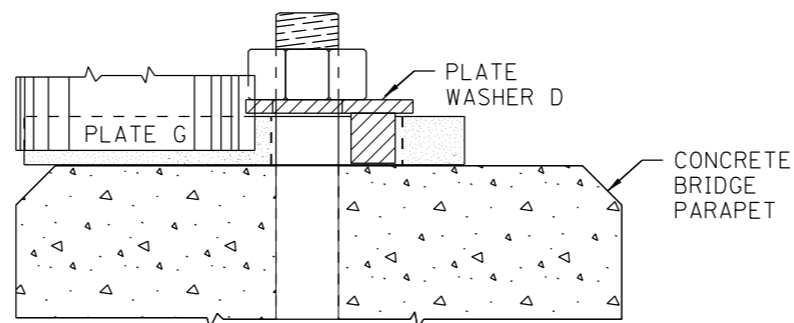

PLATE WASHER D



PLACEMENT OF PLATE WASHER D  
(PLAN)

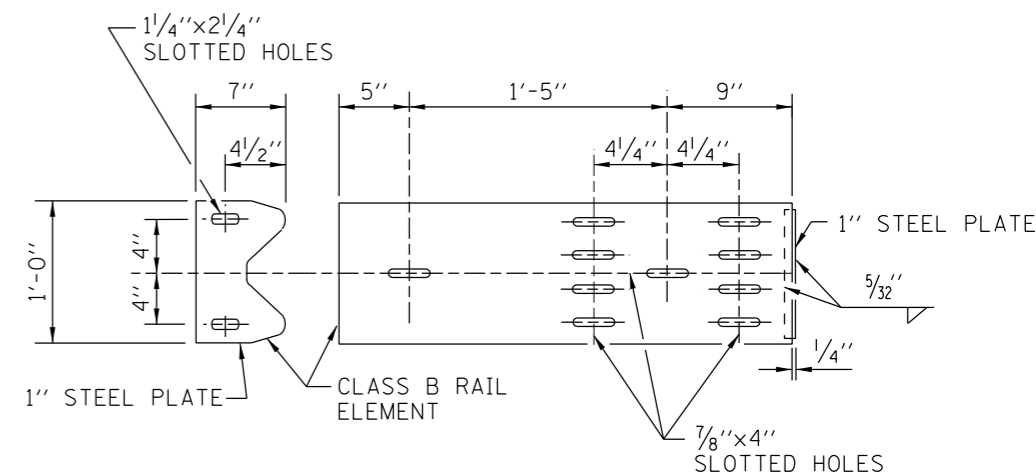

PLATE G

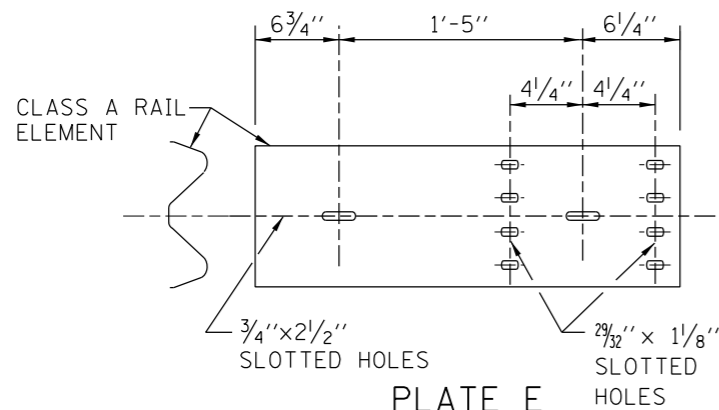

PLATE E

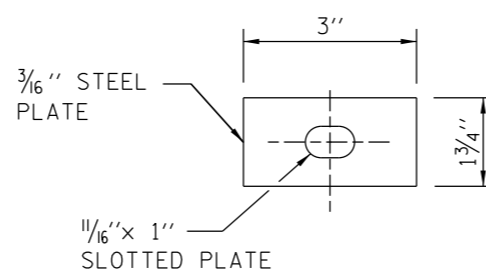
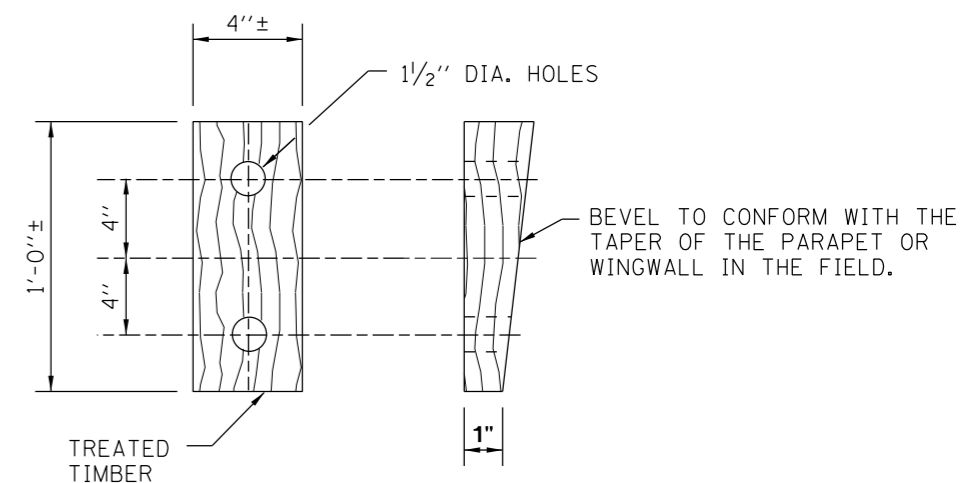

PLATE WASHER F



WEDGE M

**NOTE:**

SEE SHEET 1 OF THIS SERIES FOR NOTES.

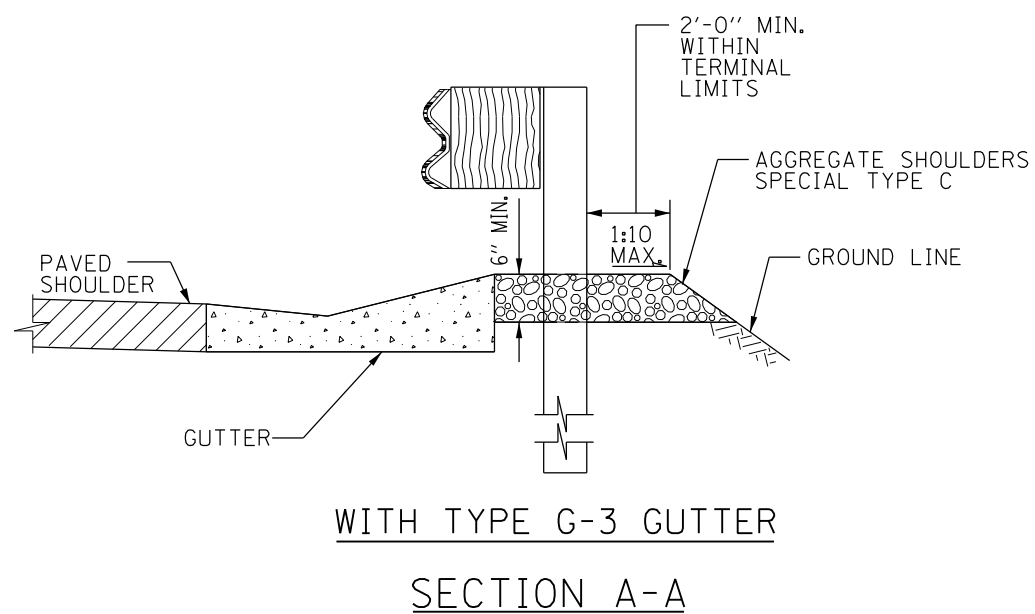
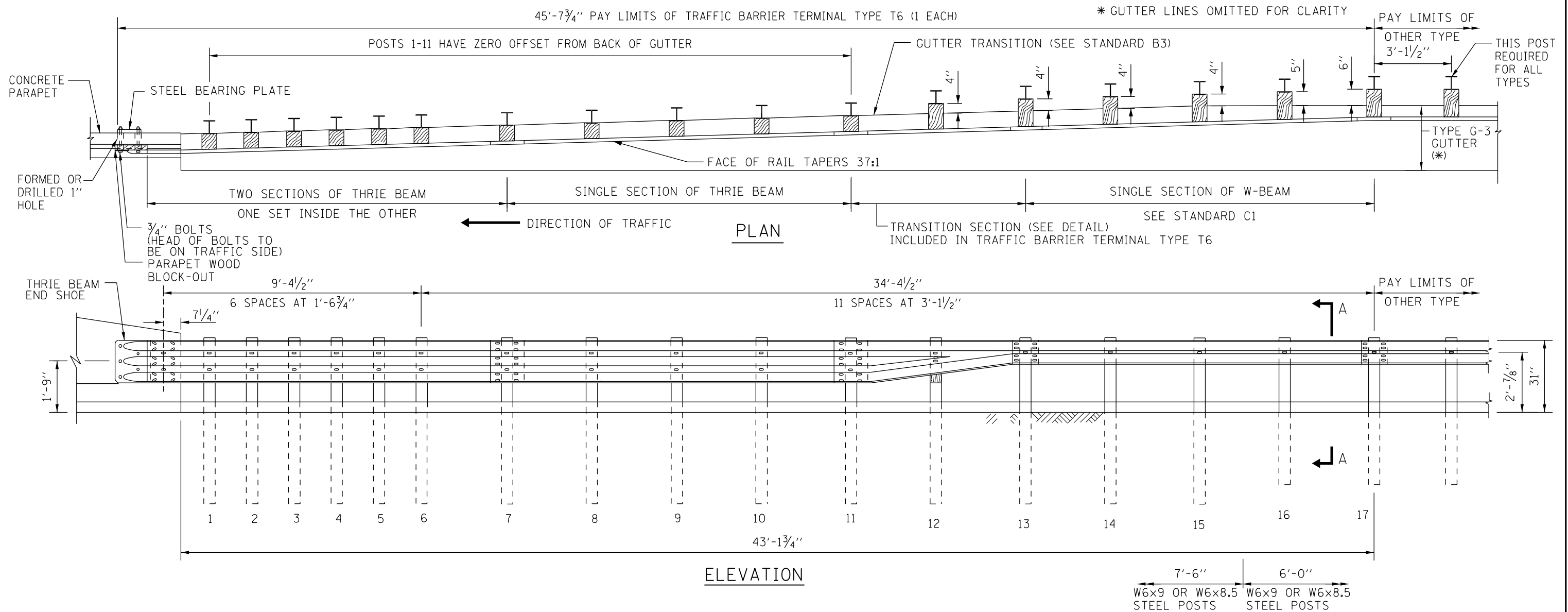

**NOTES:**

- SEE STANDARD C1 FOR DETAILS OF GUARDRAIL NOT SHOWN.
- THRIE BEAM RAIL SHALL BE BOLTED TO BLOCK-OUT AT ALL POSTS.
- ALL SLOPE RATIOS ARE EXPRESSED AS UNITS OF VERTICAL DISPLACEMENT TO UNITS OF HORIZONTAL DISPLACEMENT (V:H).
- THE TYPE T6 TERMINAL IS TYPICALLY UTILIZED TO ATTACH GALVANIZED STEEL PLATE BEAM GUARDRAIL AT THE UPSTREAM END OF THE BRIDGES CONCRETE PARAPET, WHERE A ROADSIDE GUTTER IS TO BE INSTALLED.
- SEE STANDARD B3 FOR GUTTER TRANSITION AT TRAFFIC BARRIER TERMINAL TYPE T6.
- UNDER NO CIRCUMSTANCES SHALL AN EXISTING TERMINAL, THAT WAS DESIGNED USING A PREVIOUS STANDARD, BE ATTACHED TO OR MODIFIED IN ANYWAY FROM ITS ORIGINAL DESIGN. IF ANY MODIFICATION IS REQUIRED AND A PROPER WARRANT HAS BEEN COMPLETED, THE ENTIRE BARRIER INSTALLATION SHALL BE COMPLETELY REMOVED AND REPLACED WITH A NEW SYSTEM THAT CONFORMS TO THE CURRENT STANDARD.
- TRAFFIC BARRIER TERMINAL SHALL BE IN ACCORDANCE WITH THE MANUFACTURER'S DETAILS AND SPECIFICATIONS.
- TERMINAL POSTS SHALL NOT BE INSTALLED IN CONCRETE OR HMA PAVEMENTS. WHEN NECESSARY USE LEAVE-OUT DETAIL PER STANDARD C1.
- TERMINAL POSTS TO BE INSTALLED PERPENDICULAR TO BACK OF GUTTER.
- THE TERMINAL SYSTEM HAS BEEN PERFORMANCE-TESTED FOR CASHWORTHINESS UNDER PROCEDURES DEFINED IN THE NATIONAL COOPERATIVE HIGHWAY RESEARCH PROGRAM (NCHRP) REPORT 350. NO MODIFICATION TO THIS STANDARD DRAWING SHALL BE PERMITTED.
- TERMINAL BARRIER CLEARANCE DISTANCE SHALL CONFORM WITH TABLE 2 ON STANDARD C1.
- LEAVE-OUT DIMENSION BEHIND POSTS 1-6, SHALL BE A MINIMUM OF 4".

SHEET 1 OF 4



FOR PARAPET (SAFETY FACE)  
WITH TYPE G-3 GUTTER

APPROVED *Paul Kovacs* CHIEF ENGINEER DATE 7-1-2009

REVISIONS	
1-1-2011	REMOVED PARAPET TOE CHAMFER, REVISED BLOCKOUT DIMENSION
2-7-2012	REVISED BOLT NOTES, ANCHORAGE ADHESIVE AND REVISED NOTES.
11-1-2012	MODIFIED AGGREGATE SHOULDERS, REVISED NOTES.

TRAFFIC BARRIER  
TERMINAL, TYPE T6

STANDARD C9-04

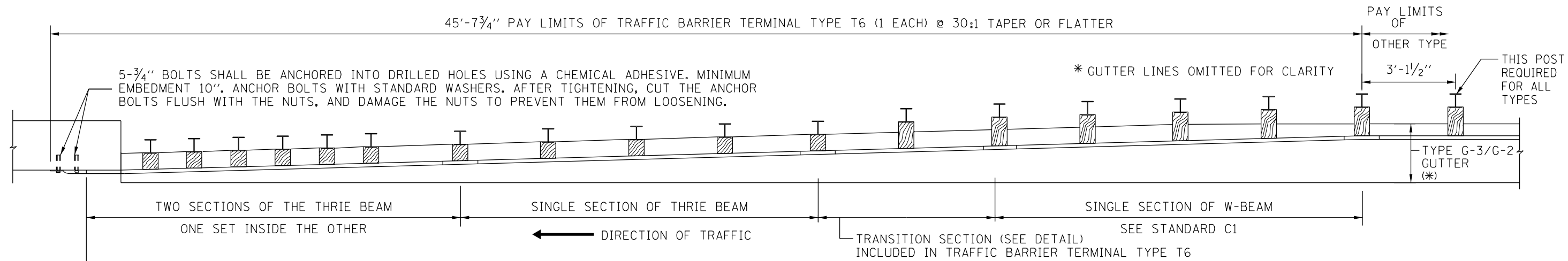

PLAN

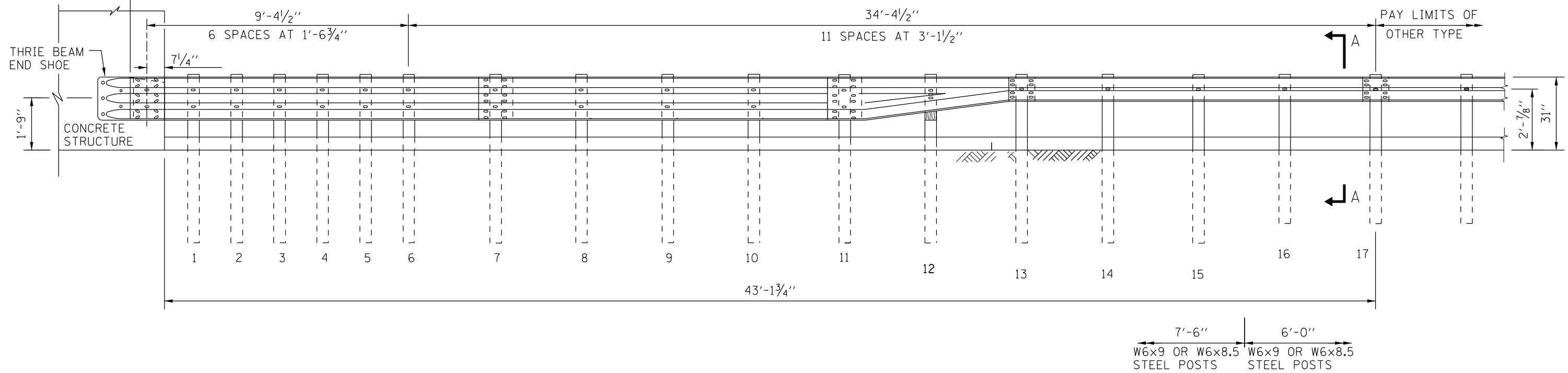

FOR OTHER CONCRETE STRUCTURE (VERTICAL FACE)  
WITH TYPE G-3/G-2 GUTTER

**NOTE:**  
SEE SHEET 1 OF THIS SERIES FOR NOTES.

*Paul Kovacs*  
APPROVED CHIEF ENGINEER DATE 7-1-2009

**Illinois Tollway**  
*Open Roads for a Faster Future*

TRAFFIC BARRIER TERMINAL, TYPE T6

STANDARD C9-04

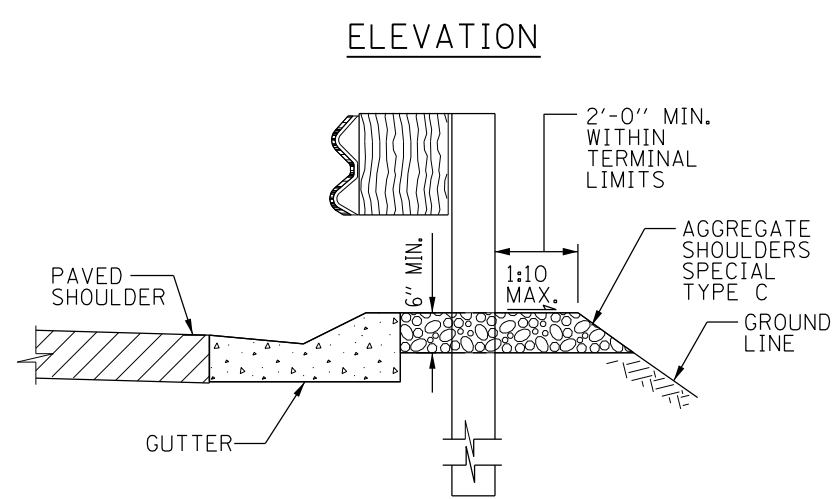
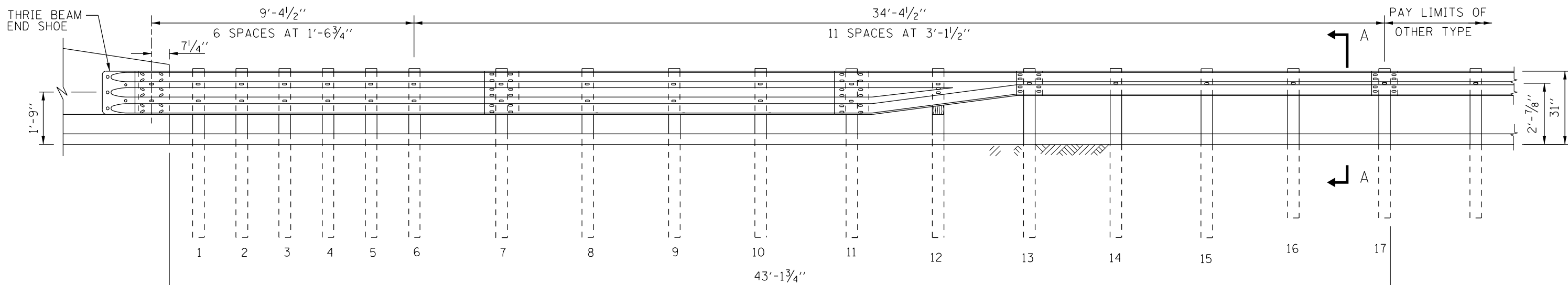
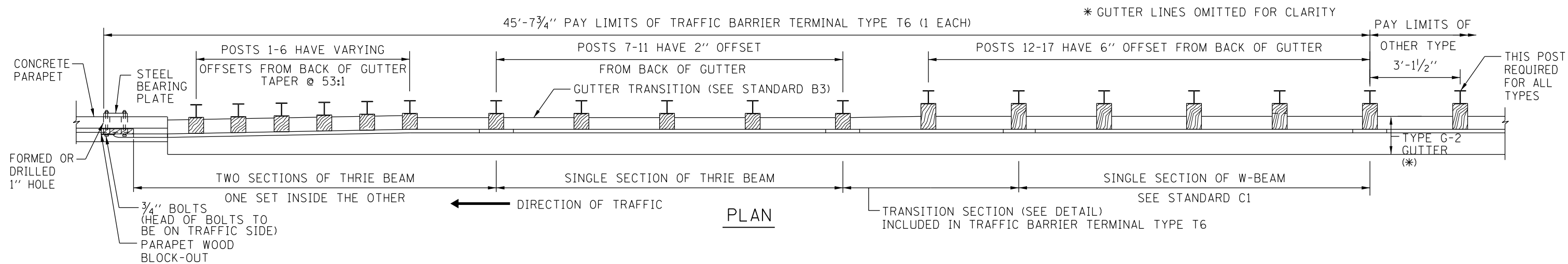

WITH TYPE G-2 GUTTER  
SECTION A-A

7'-6" 6'-0"  
W6x9 OR W6x8.5 STEEL POSTS W6x9 OR W6x8.5 STEEL POSTS

NOTE:  
SEE SHEET 1 OF THIS SERIES FOR NOTES.

FOR PARAPET (SAFETY FACE)  
WITH TYPE G-2 GUTTER

APPROVED *Paul Kovacs* CHIEF ENGINEER DATE 7-1-2009

SHEET 3 OF 4

**Illinois Tollway**  
*Open Roads for a Faster Future*

TRAFFIC BARRIER  
TERMINAL, TYPE T6

STANDARD C9-04

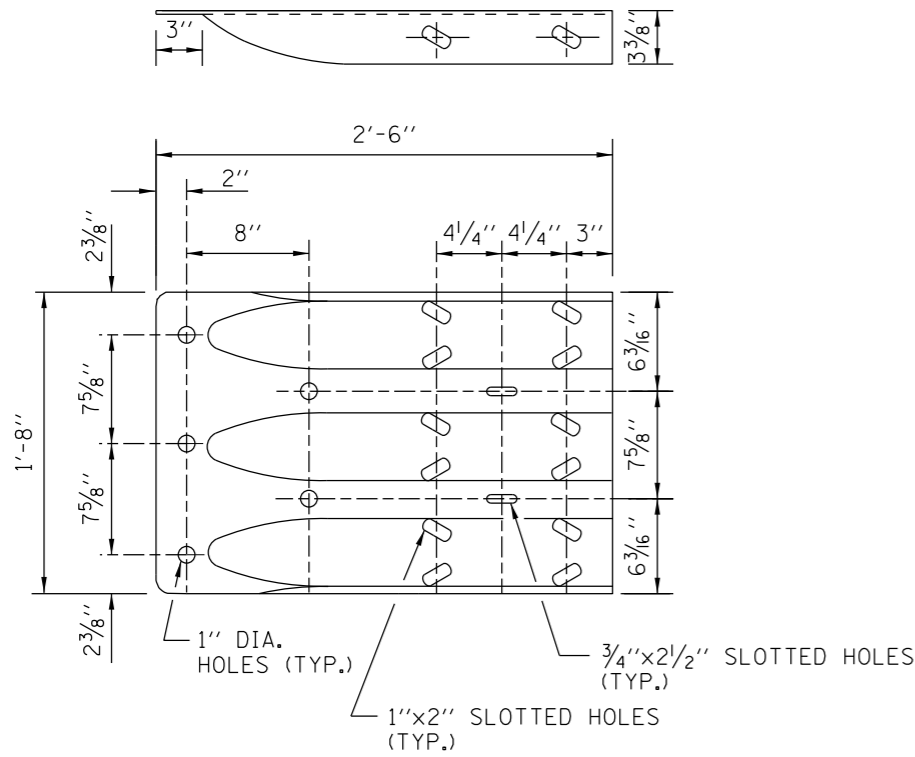

THRIE BEAM END SHOE DETAIL

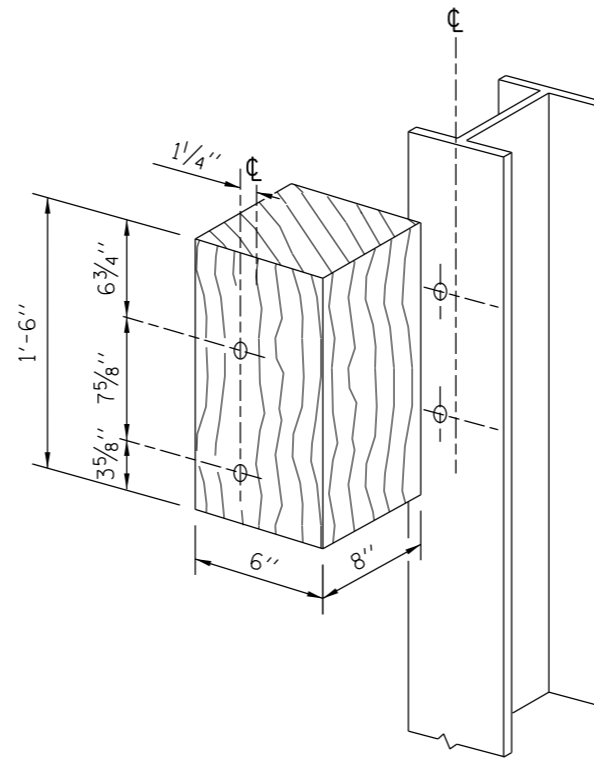

POSTS 1-11 WOOD BLOCKOUT DETAIL

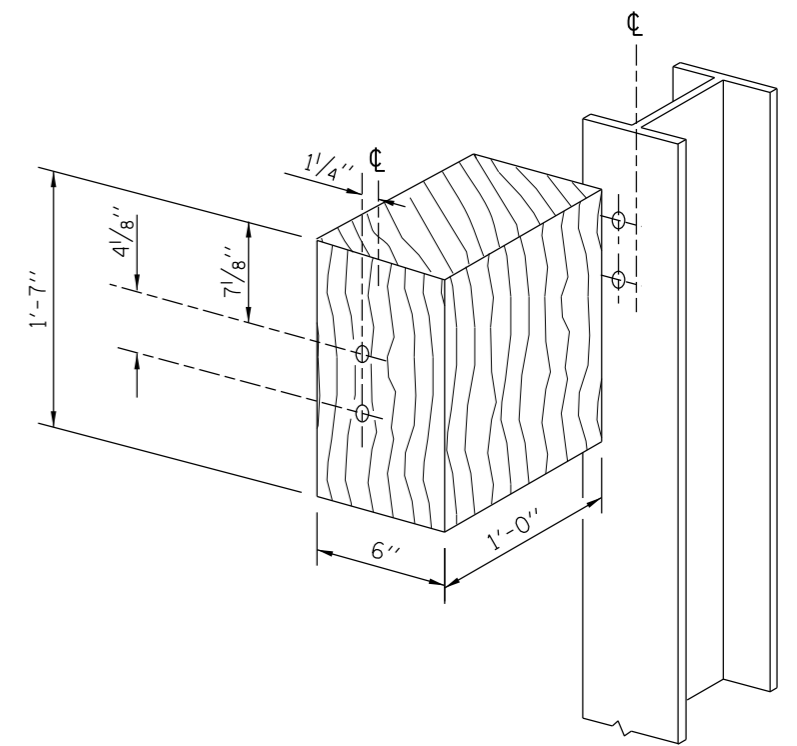

POST 12 WOOD BLOCKOUT DETAIL  
(SEE STANDARD C1 FOR POST 13-17 BLOCKOUTS.)

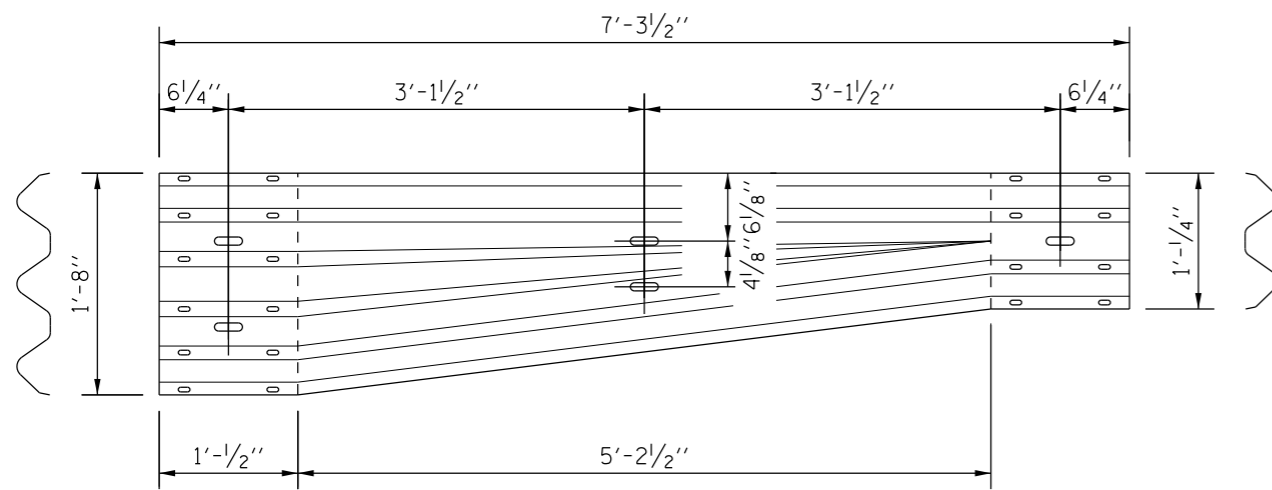

TRANSITION SECTION  
(10 GAUGE RAIL ELEMENT)

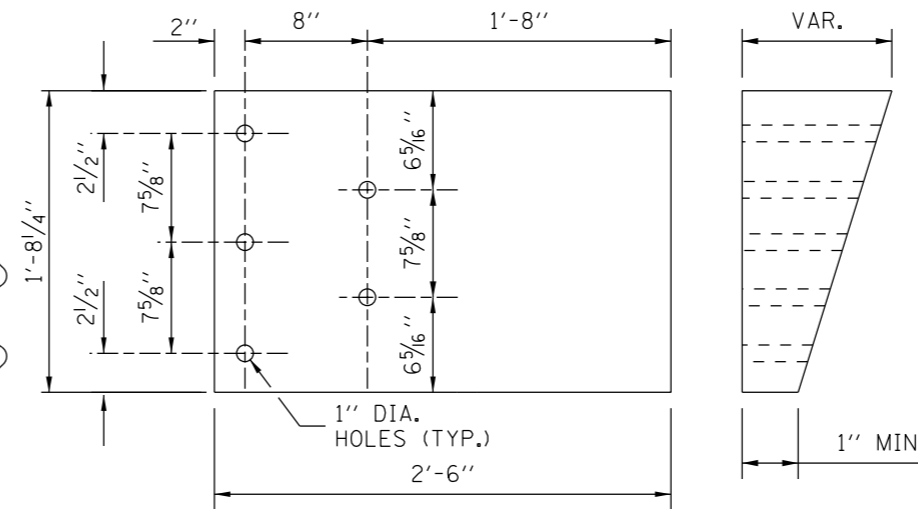

PARAPET WOOD BLOCK-OUT DETAIL

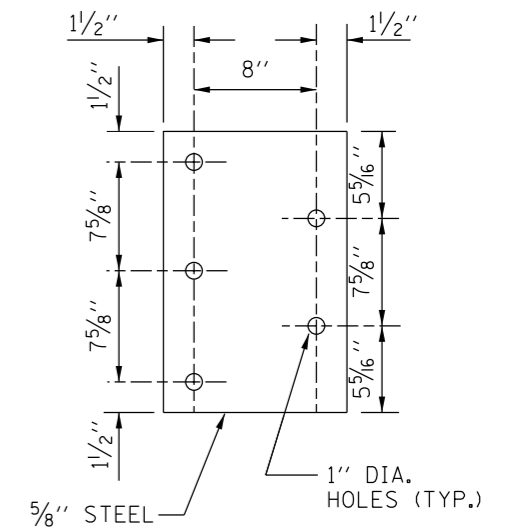

PARAPET STEEL BEARING PLATE DETAIL  
(5 EACH INDIVIDUAL 5" x 5" x 5/8" STEEL PLATES WITH CENTERED 1" HOLES MAY BE SUBSTITUTED FOR THE PLATE SHOWN.)

APPROVED *Paul Kovacs* CHIEF ENGINEER DATE 7-1-2009

NOTE:  
SEE SHEET 1 OF THIS SERIES FOR NOTES.

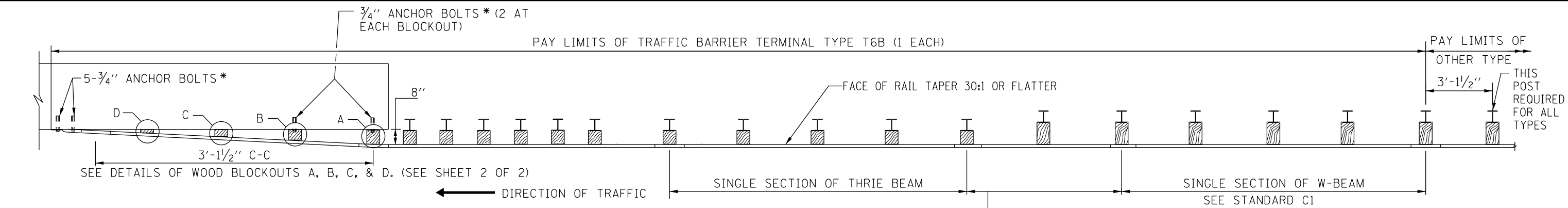

PLAN

\* WITH STANDARD WASHERS. AFTER TIGHTENING, CUT THE ANCHOR BOLTS FLUSH WITH THE NUTS AND DAMAGE THE NUTS TO PREVENT THEM FROM LOOSENING. BOLTS SHALL BE ANCHORED INTO DRILLED HOLES USING A CHEMICAL ADHESIVE. MINIMAL EMBEDMENT 10".

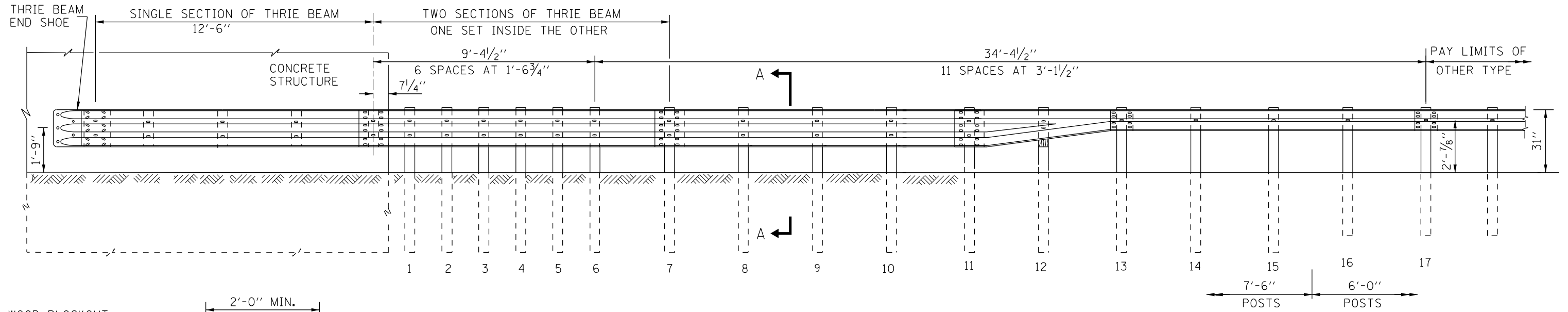

ELEVATION

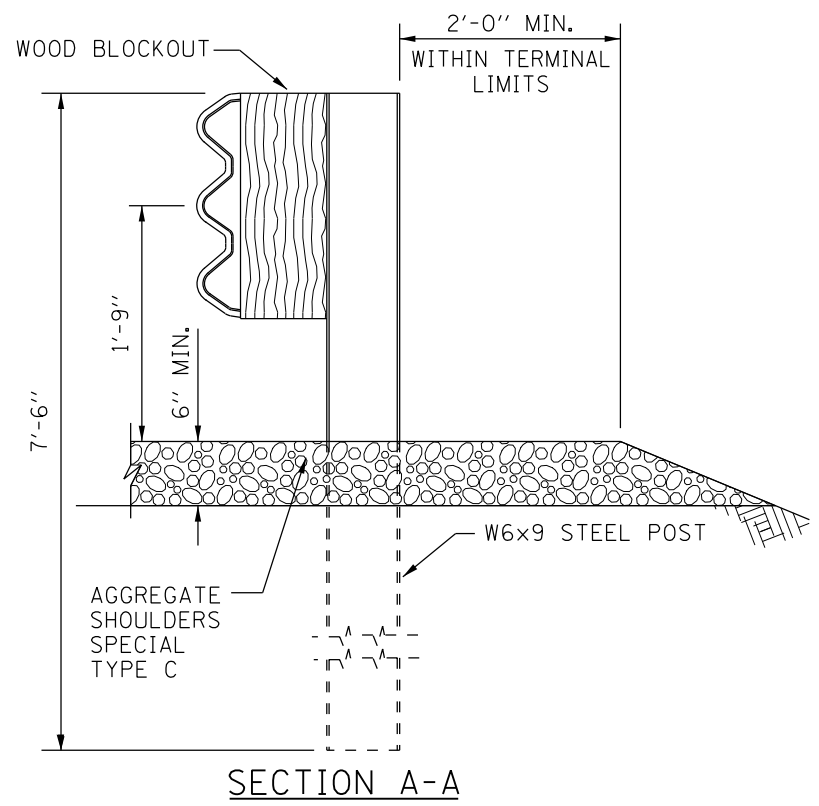

SECTION A-A

NOTES:

1. SEE STANDARD C1 FOR DETAILS OF GUARDRAIL NOT SHOWN.
2. THRIE BEAM RAIL SHALL BE BOLTED TO BLOCK-OUT AT ALL POSTS.
3. ALL SLOPE RATIOS ARE EXPRESSED AS UNITS OF VERTICAL DISPLACEMENT TO UNITS OF HORIZONTAL DISPLACEMENT (V:H).
4. THE TYPE T6B TERMINAL IS TYPICALLY UTILIZED TO ATTACH GALVANIZED STEEL PLATE BEAM GUARDRAIL AT THE UPSTREAM END OF THE BRIDGE CONCRETE PARAPET, WHERE A ROADSIDE GUTTER IS NOT TO BE INSTALLED.
5. UNDER NO CIRCUMSTANCES SHALL EXISTING TERMINAL, THAT WAS DESIGNED USING A PREVIOUS STANDARD, BE ATTACHED TO OR MODIFIED IN ANYWAY FROM ITS ORIGINAL DESIGN. IF ANY MODIFICATION IS REQUIRED AND A PROPER BARRIER WARRANT HAS BEEN COMPLETED, THE ENTIRE BARRIER INSTALLATION SHALL BE COMPLETELY REMOVED AND REPLACED WITH A NEW SYSTEM THAT CONFORMS TO THE CURRENT STANDARD.
6. TRAFFIC BARRIER TERMINAL SHALL BE IN ACCORDANCE WITH THE MANUFACTURE'S DETAILS AND SPECIFICATIONS.
7. TERMINAL POSTS SHALL NOT BE INSTALLED IN CONCRETE OR HMA PAVEMENTS. WHEN NECESSARY USE LEAVE-OUT DETAIL PER STANDARD C1, SHEET 4 OF 4.
8. TERMINAL BARRIER CLEARANCE DISTANCE SHALL CONFORM WITH TABLE 2 ON STANDARD C1.
9. LEAVE-OUT DIMENSION BEHIND POSTS 1-6, SHALL BE A MINIMUM OF 4".

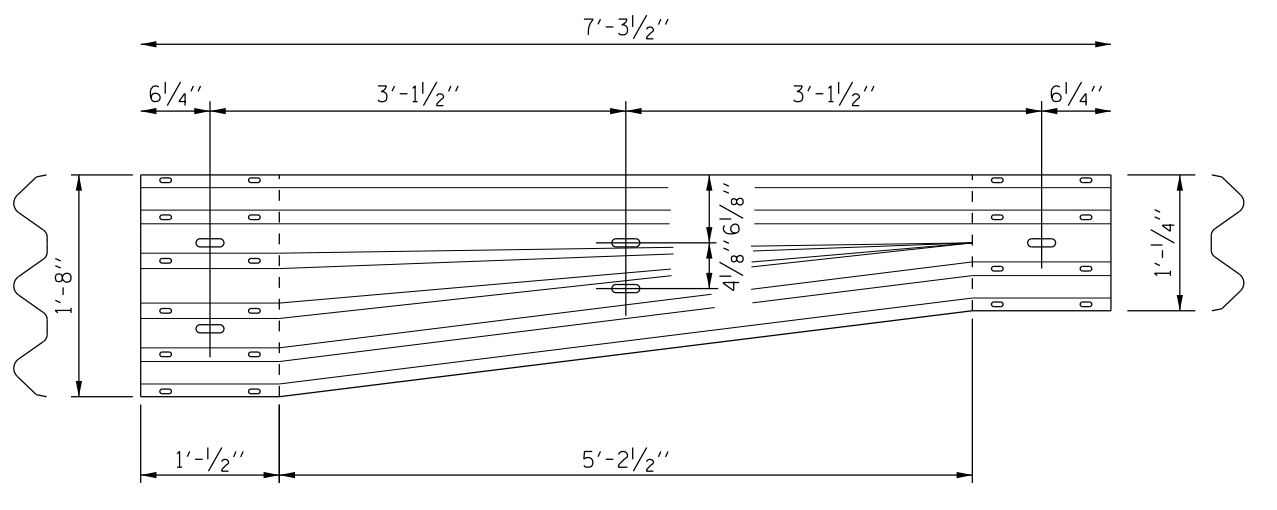

TRANSITION SECTION

(10 GAUGE RAIL ELEMENT)

APPROVED *Paul Kovacs* CHIEF ENGINEER DATE 7-1-2009

REVISIONS	
1-1-2011	REMOVED EMBANKMENT SLOPE, REVISED WOOD BLOCKOUT DIMENSION
2-7-2012	REVISED WOOD BLOCKOUT DIMENSION, ADHESIVE AND REVISED NOTES.
11-1-2012	MODIFIED AGGREGATE SHOULDERS, REVISED NOTES

**Illinois Tollway**  
Open Roads for a Faster Future

TRAFFIC BARRIER TERMINAL, TYPE T6B

STANDARD C10-04



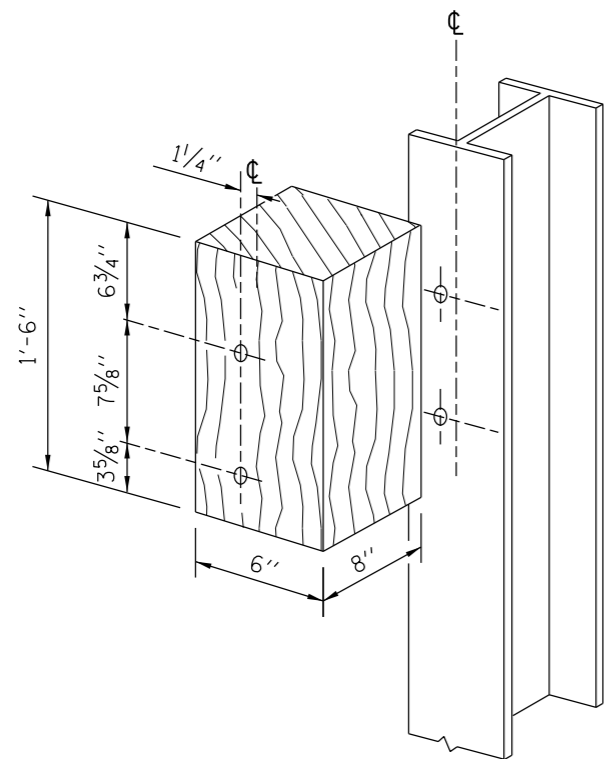

POSTS 1-11 WOOD BLOCKOUT DETAIL

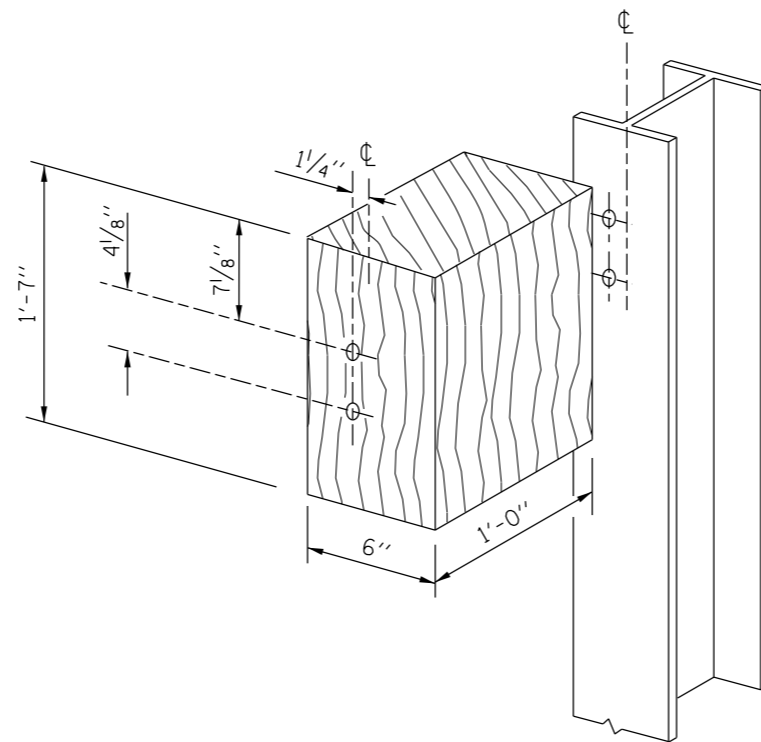

POST 12 WOOD BLOCKOUT DETAIL

(SEE STANDARD C1 FOR POST 13-17 BLOCKOUTS)

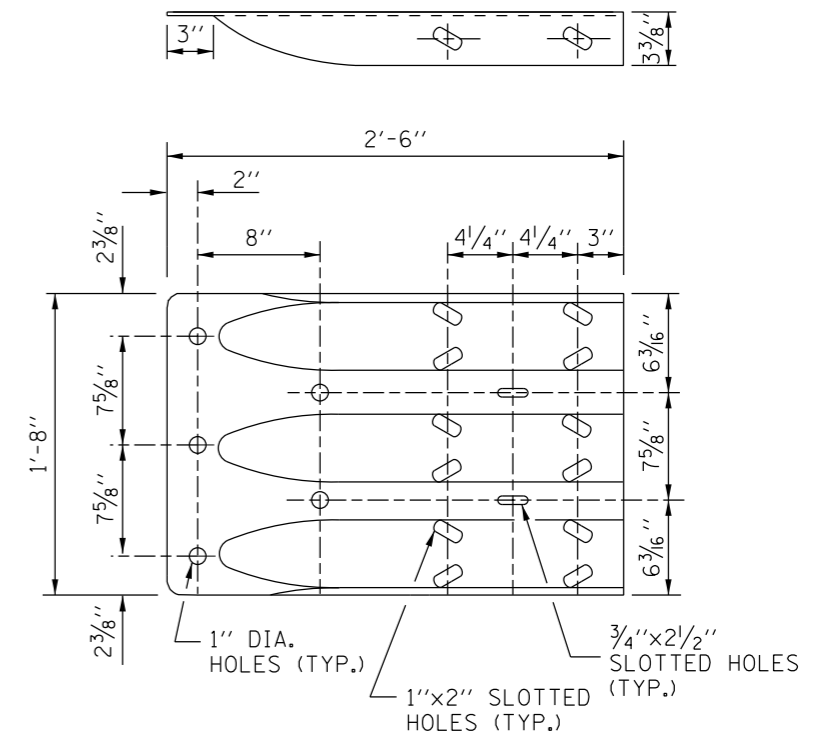

THRIE BEAM END SHOE DETAIL

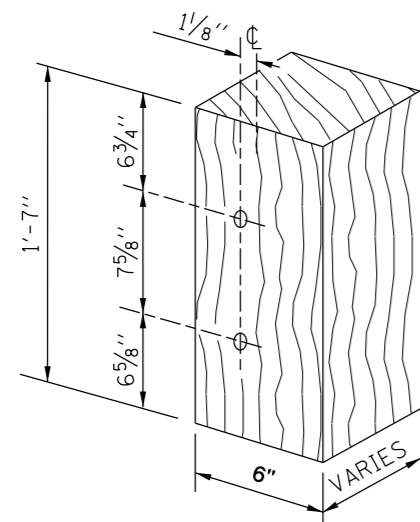

MODIFIED THICKNESS DETAIL  
WOOD BLOCKOUTS A, B, C, & D

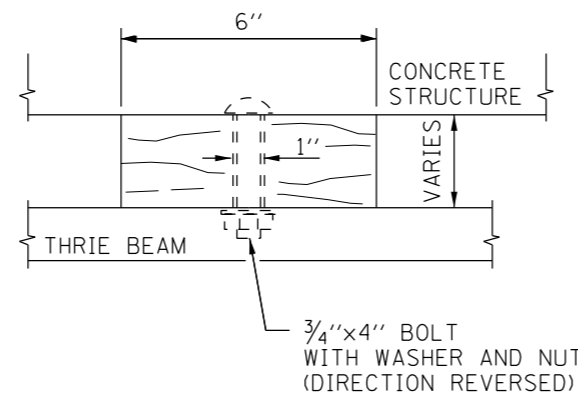

WOOD BLOCKOUT D

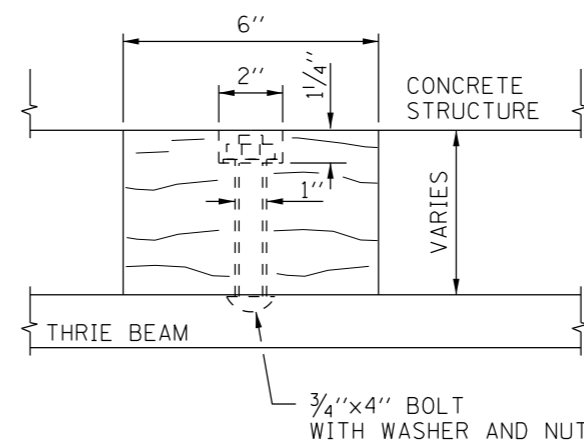

WOOD BLOCKOUT C

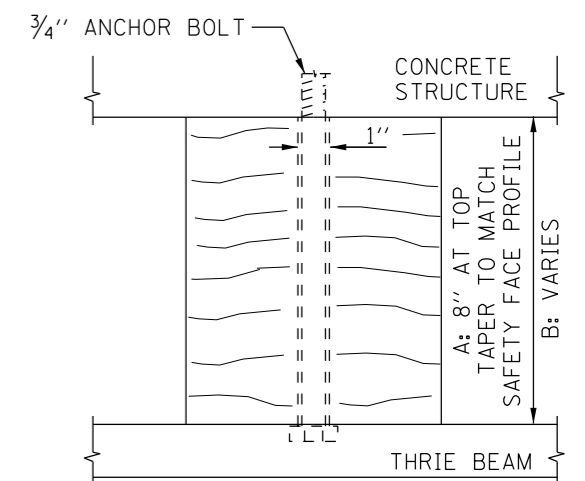

WOOD BLOCKOUT A & B

**NOTE:**

SEE SHEET 1 OF THIS SERIES FOR NOTES.

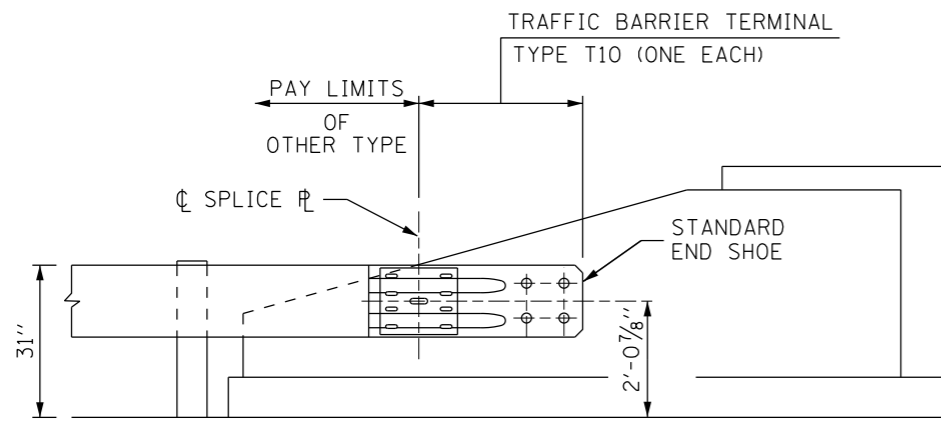

**ELEVATION**

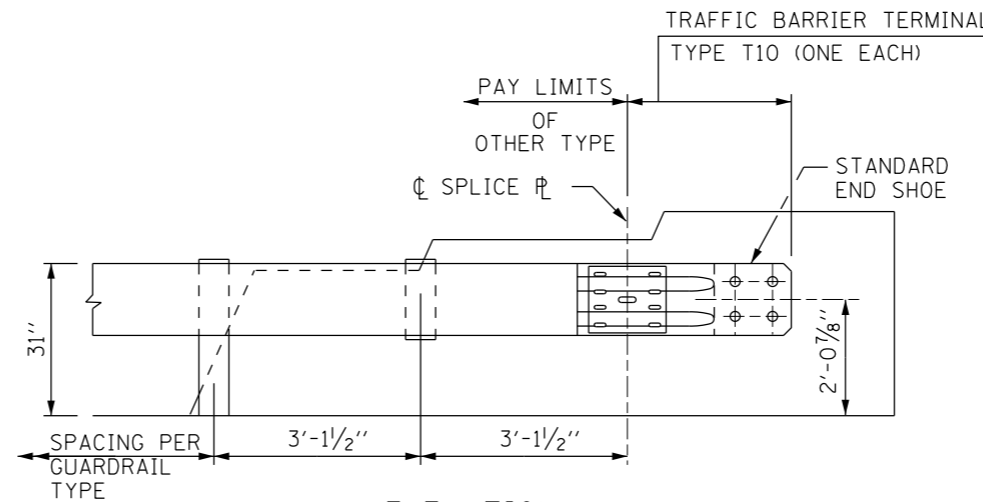

**ELEVATION**

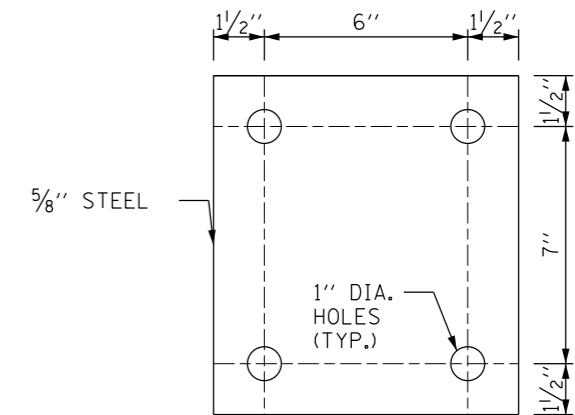

**PARAPET STEEL BEARING PLATE DETAIL**

(4 EACH INDIVIDUAL 5"x5"x5/8" STEEL PLATES WITH CENTERED HOLES MAY BE SUBSTITUTED FOR THE PLATE SHOWN)

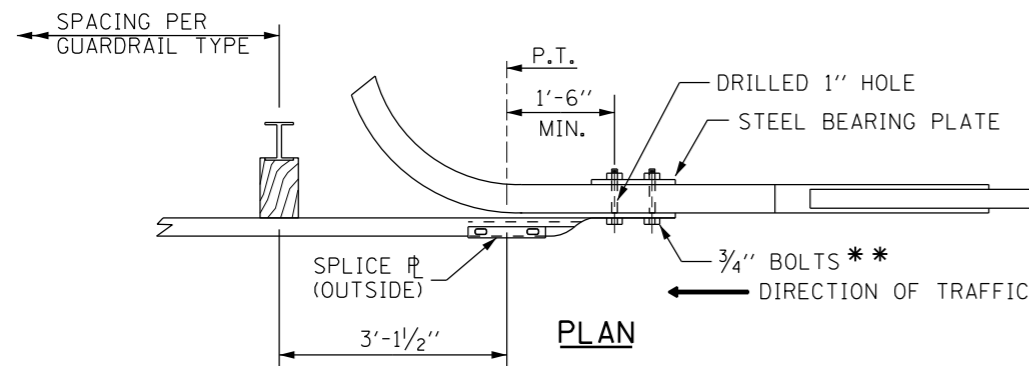

**PLAN**

**CURVED WING**

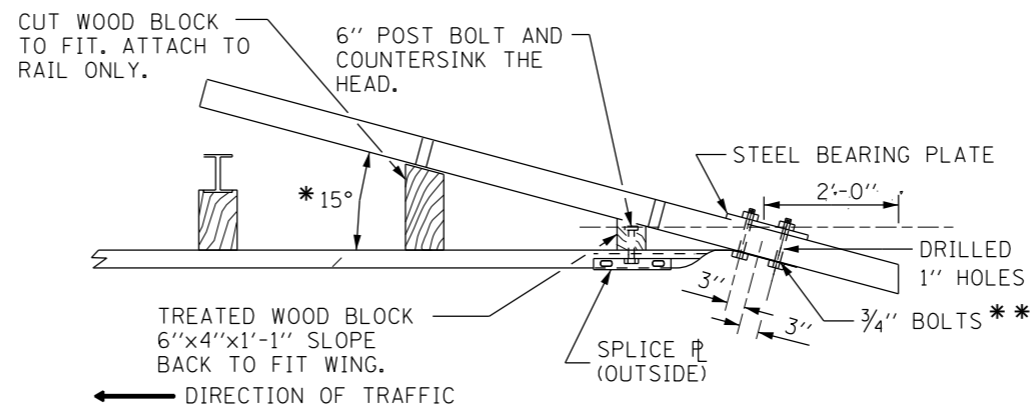

**PLAN**

**FLARED WING**

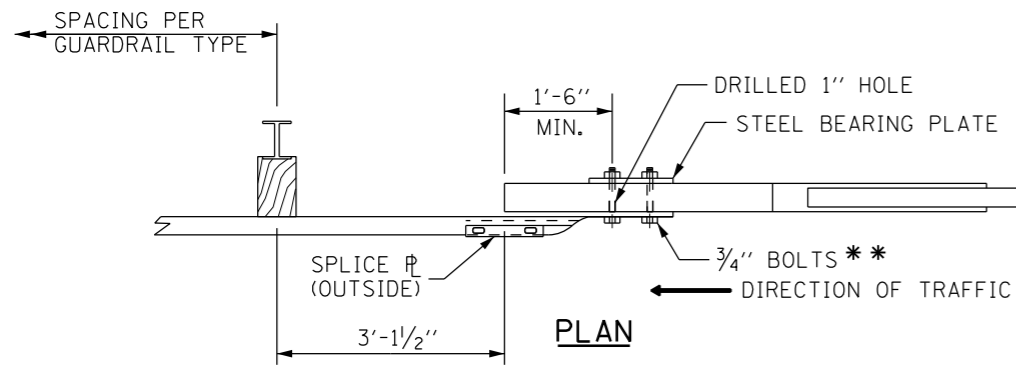

**PLAN**

**TANGENT WING**

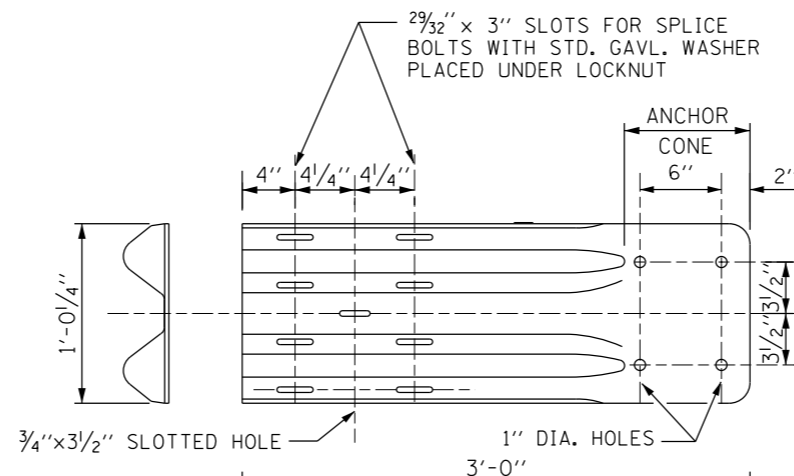

**END SHOE**

**GENERAL NOTE:**

- \* OR TO BE DETERMINED IN THE FIELD.
- \*\* HEAD OF BOLT TO BE ON TRAFFIC SIDE. SEE DETAIL "A"

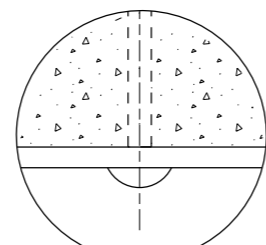

**DETAIL "A"**

**NOTES:**

1. SEE STANDARD C1 FOR DETAILS OF GUARDRAIL NOT SHOWN.
2. THE TYPE T10 TERMINAL IS TYPICALLY UTILIZED TO CONNECT GALVANIZED STEEL PLATE BEAM GUARDRAIL TO THE DEPARTING END OF AN EXISTING BRIDGE CONCRETE WING WALL OR PARAPET.
3. UNDER NO CIRCUMSTANCES SHALL AN EXISTING TERMINAL, THAT WAS DESIGNED USING A PREVIOUS STANDARD, BE ATTACHED TO OR MODIFIED IN ANYWAY FROM ITS ORIGINAL DESIGN. IF ANY MODIFICATION IS REQUIRED AND A PROPER BARRIER WARRANT HAS BEEN COMPLETED, THE ENTIRE BARRIER INSTALLATION SHALL BE COMPLETELY REMOVED AND REPLACED WITH A NEW SYSTEM THAT CONFORMS TO THE CURRENT STANDARD.
4. TRAFFIC BARRIER TERMINAL SHALL BE IN ACCORDANCE WITH THE MANUFACTURER'S DETAILS AND SPECIFICATIONS.
5. WHEN END SHOE IS ATTACHED TO A BRIDGE PARAPET WHICH HAS AN EXPANSION JOINT, THE BOLTS SHALL BE PROVIDED WITH A LOCKNUT OR DOUBLE NUT AND SHALL BE TIGHTENED ONLY TO A POINT THAT WILL ALLOW GUARDRAIL MOVEMENT.
6. THE ANCHOR CONE SHALL BE SET FLUSH WITH THE SURFACE OF THE CONCRETE.
7. EXTERNALLY THREADED STUDS PROTRUDING FROM THE SURFACE OF THE CONCRETE WILL NOT BE PERMITTED.

*Paul Kovacs*  
APPROVED CHIEF ENGINEER DATE 7-1-2009

DATE	REVISIONS
3-1-2010	REVISED NOTES, ADDED END SHOE AND PARAPET BEARING PLATE DETAIL.
1-1-2011	REVISED END SHOE HEIGHT ATTACHMENT.
2-7-2012	REVISED BOLT NOTE, ADDED DETAIL "A" AND REVISED NOTES.



TRAFFIC BARRIER TERMINAL, TYPE T10

STANDARD C11-03

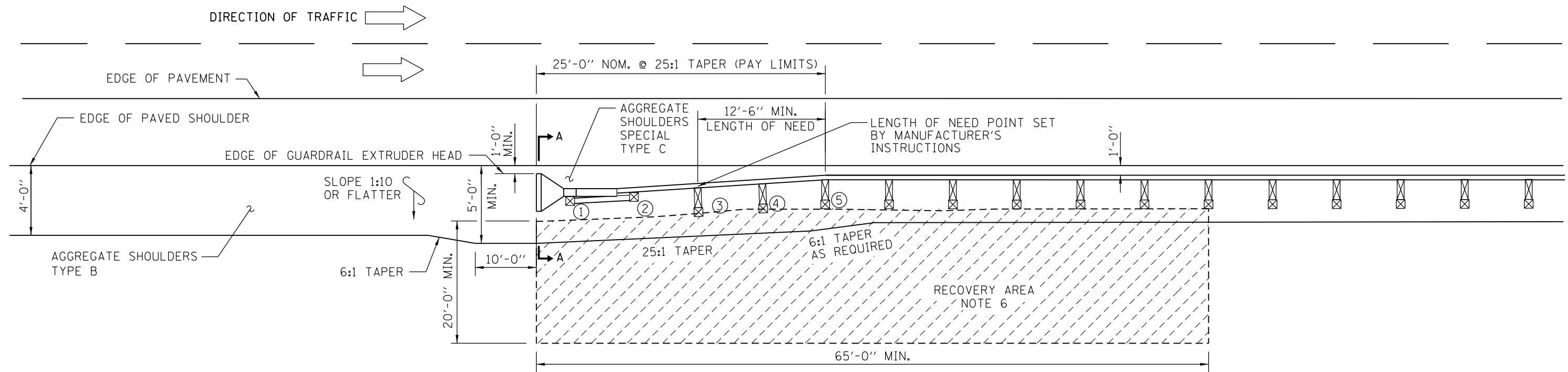

**SHOULDER WIDENING TRANSITION-WITHOUT GUTTER  
FOR TRAFFIC BARRIER TERMINAL TYPE T1-A (SPECIAL)**

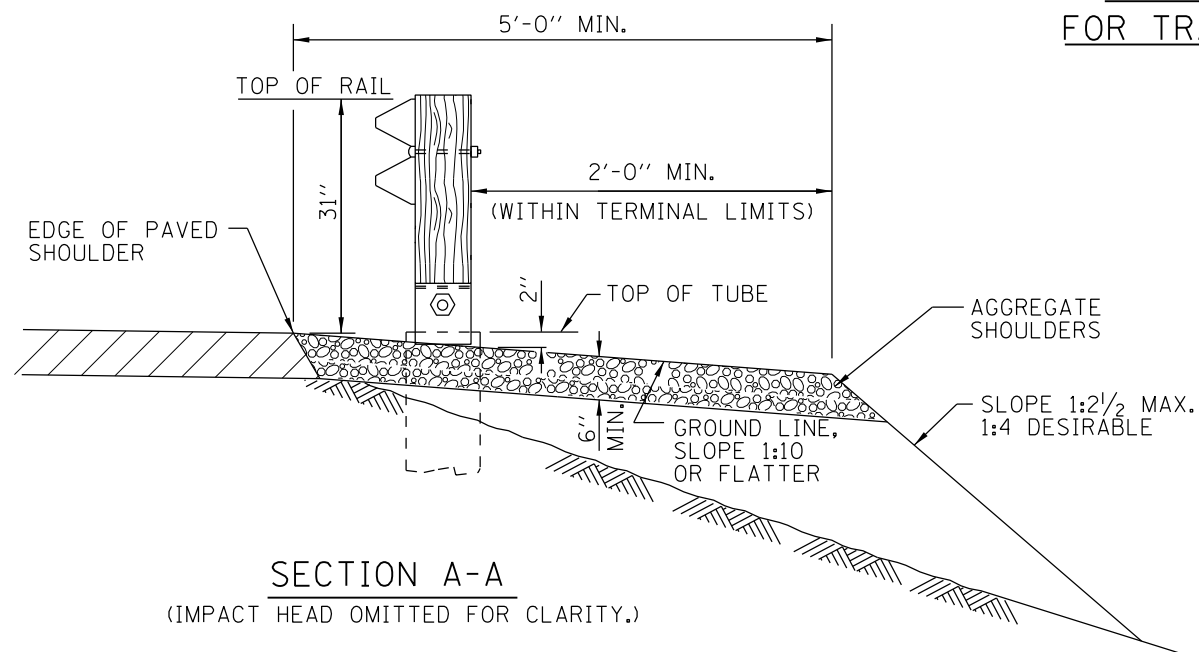

**SECTION A-A**  
(IMPACT HEAD OMITTED FOR CLARITY.)

**GENERAL NOTES:**

1. ALL SLOPE RATIOS ARE EXPRESSED AS UNITS OF VERTICAL DISPLACEMENT TO UNITS OF HORIZONTAL DISPLACEMENT (V:H).
2. THE TYPE T1-A (SPECIAL) IS THE UPSTREAM END SECTION OF A GALVANIZED STEEL PLATE BEAM GUARDRAIL BARRIER SYSTEM, FOR RAMP INSTALLATION WITH POSTED SPEED LIMIT OF 40 MPH OR LESS, NCHRP 350, TEST LEVEL (TL-2).
3. REFERENCE STANDARD B29 FOR GUTTER TRANSITION AT TRAFFIC BARRIER TERMINAL TYPE T1-A (SPECIAL).
4. UNDER NO CIRCUMSTANCES SHALL AN EXISTING TERMINAL, THAT WAS DESIGNED USING A PREVIOUS STANDARD, BE ATTACHED TO OR MODIFIED IN ANYWAY FROM ITS ORIGINAL DESIGN. IF ANY MODIFICATION IS REQUIRED AND A PROPER BARRIER WARRANT HAS BEEN COMPLETED, THE ENTIRE BARRIER INSTALLATION SHALL BE COMPLETELY REMOVED AND REPLACED WITH A NEW SYSTEM THAT CONFORMS TO THE CURRENT STANDARD.
5. TRAFFIC BARRIER TERMINAL SHALL BE IN ACCORDANCE WITH THE MANUFACTURER'S DETAILS AND SPECIFICATIONS.
6. NO ROADSIDE OBSTRUCTION OF ANY TYPE-FIXED OR BREAKAWAY, EITHER TEMPORARY OR PERMANENT SHALL BE ALLOWED WITHIN THIS RECOVERY AREA.
7. NO CURVED W-BEAM SECTIONS ARE PERMITTED WITHIN THE TERMINAL PAY LIMITS. THE TRAFFIC BARRIER TERMINAL TYPE T1-A (SPECIAL) SHALL BE LAID OUT IN A STRAIGHT LINE.
8. TERMINAL POSTS SHALL NOT BE INSTALLED IN CONCRETE OR HMA. WHEN NECESSARY USE LEAVE-OUT DETAIL SHOWN ON STANDARD C1.
9. THE TERMINAL SYSTEM HAS BEEN PERFORMANCE-TESTED FOR CRASHWORTHINESS UNDER PROCEDURES DEFINED IN THE NATIONAL COOPERATIVE HIGHWAY RESEARCH REPORT (NCHRP) REPORT 350. NO MODIFICATION TO THIS STANDARD DRAWING SHALL BE PERMITTED.

**NOTES FOR INSTALLATION ON TANGENT ROADWAY:**

TRAFFIC BARRIER TERMINAL SHALL BE INSTALLED AT A 25:1 TAPER MEASURED FROM EDGE OF TRAVELED WAY.

**NOTES FOR INSTALLATION ON CURVED ROADWAY:**

THE EDGE OF THE TERMINAL EXTRUDER HEAD SHALL BE OFFSET A DISTANCE FROM A POINT ON THE BACK OF THE CURVED EDGE OF PAVED SHOULDER AS SHOWN IN TABLE 1.



APPROVED *Paul Kovacs* CHIEF ENGINEER DATE 1-1-2011

REVISIONS	
2-7-2012	REVISED SLOPE NOTE.
11-1-2012	MODIFIED AGGREGATE SHOULDERS

TRAFFIC BARRIER TERMINAL  
TYPE T1-A (SPECIAL)

STANDARD C12-02

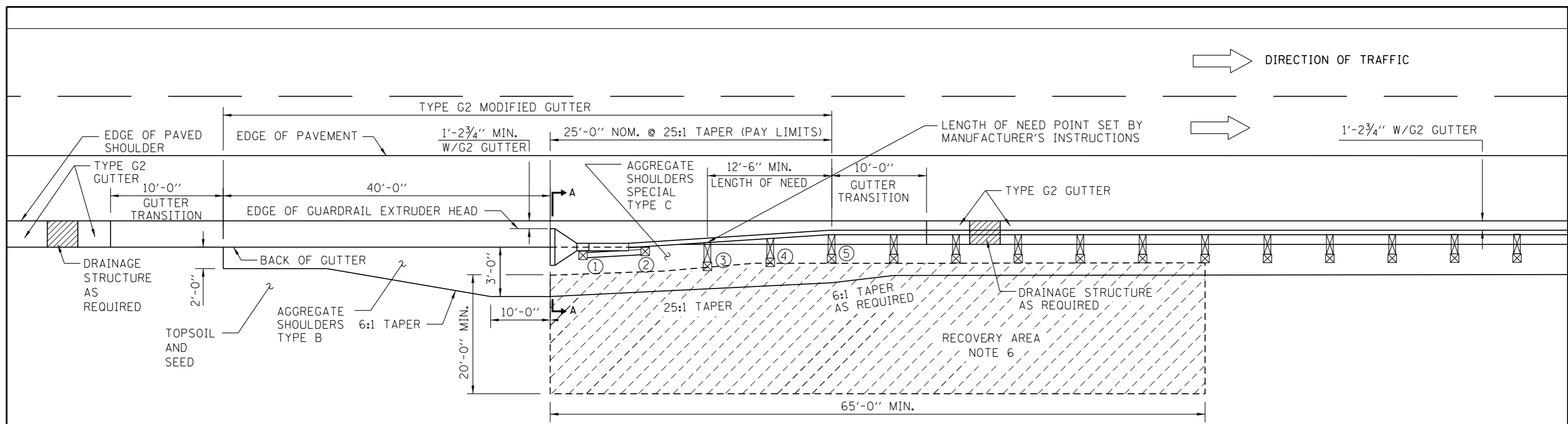

SHOULDER WIDENING TRANSITION-WITH GUTTER, TYPE G-2 FOR TRAFFIC BARRIER TERMINAL TYPE T1-A (SPECIAL)

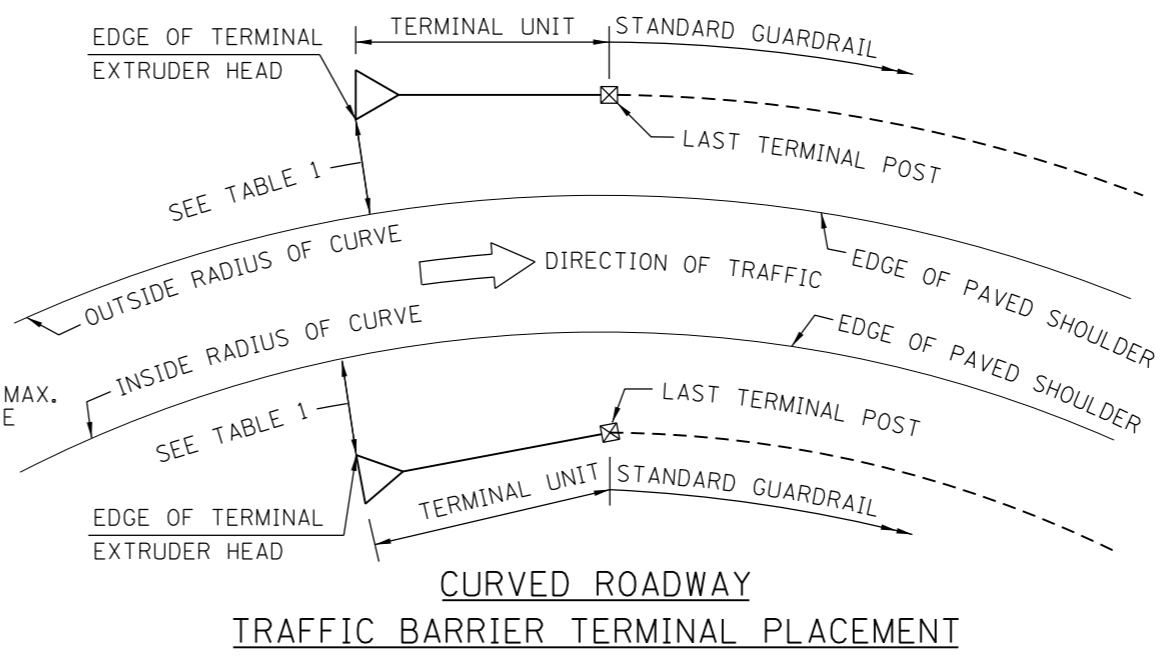
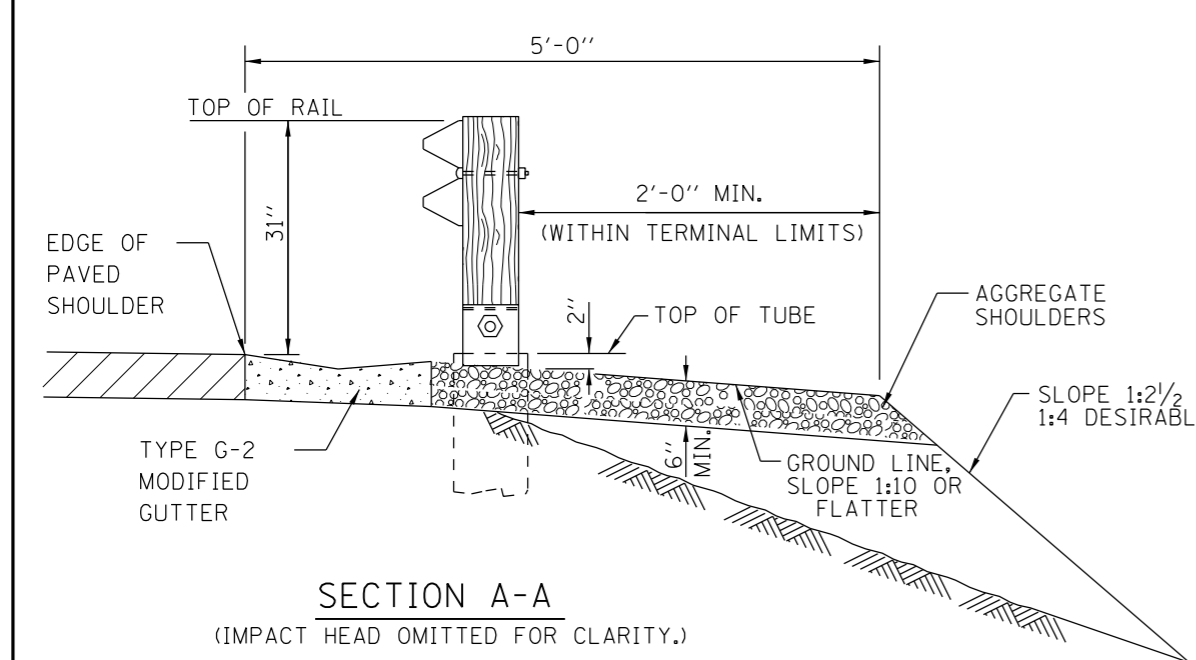

NOTE:  
SEE SHEET 1 OF THIS SERIES FOR NOTES.

TABLE 1		
LATERAL OFFSET DIMENSION TO EDGE OF TERMINAL EXTRUDER HEAD		
	INSIDE RADIUS OF CURVE	OUTSIDE RADIUS OF CURVE
NO GUTTER	1'-0"	1'-0" MIN. *
TYPE G-2 GUTTER	1'-2 3/4"	1'-2 3/4" MIN. *
TYPE G-3 GUTTER	2'-2 3/4"	2'-2 3/4" MIN. *

(\*) OFFSET DISTANCE WILL VARY BASED ON RADIUS OF HORIZONTAL CURVE AND THE TERMINAL BEING INSTALLED IN A STRAIGHT LINE.

APPROVED *Paul Kovacs* CHIEF ENGINEER DATE 1-1-2011

SHEET 2 OF 2

TRAFFIC BARRIER TERMINAL  
TYPE T1-A (SPECIAL)  
STANDARD C12-02

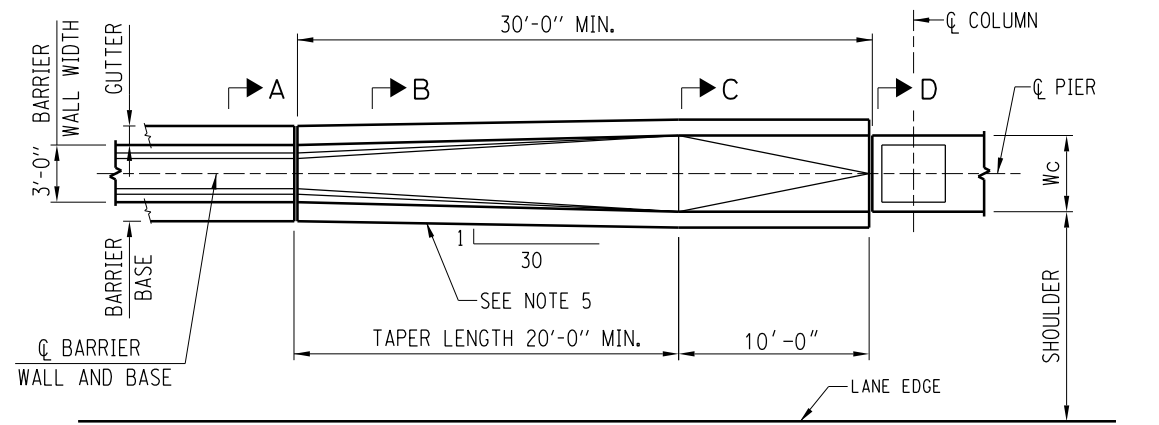

**PLAN**

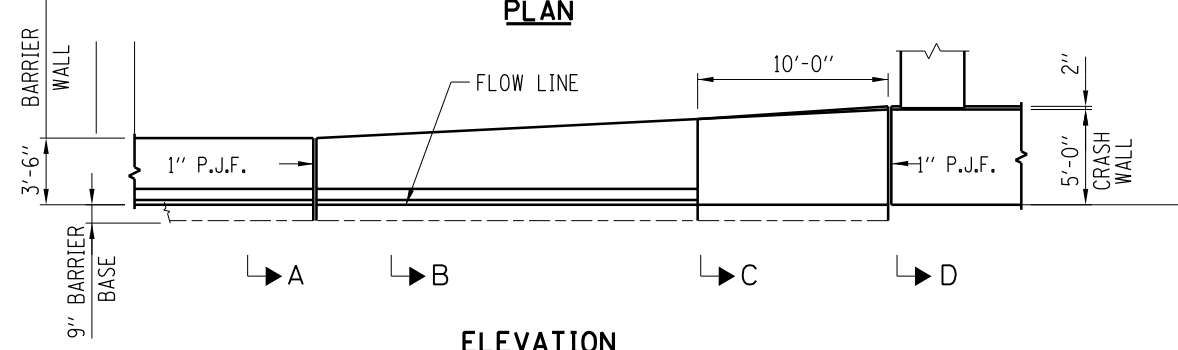

**ELEVATION**

**CONCRETE MEDIAN BARRIER TRANSITION, TYPE V-F AT BRIDGE PIERS**

**NOTES:**

1. 1" DEEP CONTRACTION JOINTS SHALL BE CONSTRUCTED IN THE CONCRETE BARRIER WALL AND IN THE CONCRETE BARRIER BASE. CONTRACTION JOINTS SHALL ALSO BE CONSTRUCTED AT BOTH SIDES OF ALL DRAINAGE STRUCTURES. MAXIMUM JOINT SPACING SHALL BE 30'
2. THE FORMING OF CONTRACTION JOINTS SHALL BE DONE WITH AN APPROVED FINISHING TOOL AT THE DISCRETION OF THE ENGINEER SUBJECT TO THE SATISFACTORY CONTROL OF CRACKING. THE SAWING OF CONTRACTION JOINTS IN THE BARRIER WALL SHALL NOT BE PERMITTED.
3. TAPER LENGTH REQUIRED FOR THE WIDTH TRANSITION WILL BE 20'-0" MINIMUM.
4. TOP SHOULDER EDGE OF GUTTER SLAB SHALL MATCH THE TOP OF SHOULDER ELEVATION.
5. GUTTER PROFILE IN THE VICINITY OF SAG VERTICAL CURVES, ALONG FLAT GRADES AND AT THE MEETING OF PROPOSED AND EXISTING GUTTER, SHALL BE CAREFULLY CONTROLLED AND FIELD ADJUSTED IF NECESSARY TO ENSURE POSITIVE DRAINAGE AND AVOID PONDING.

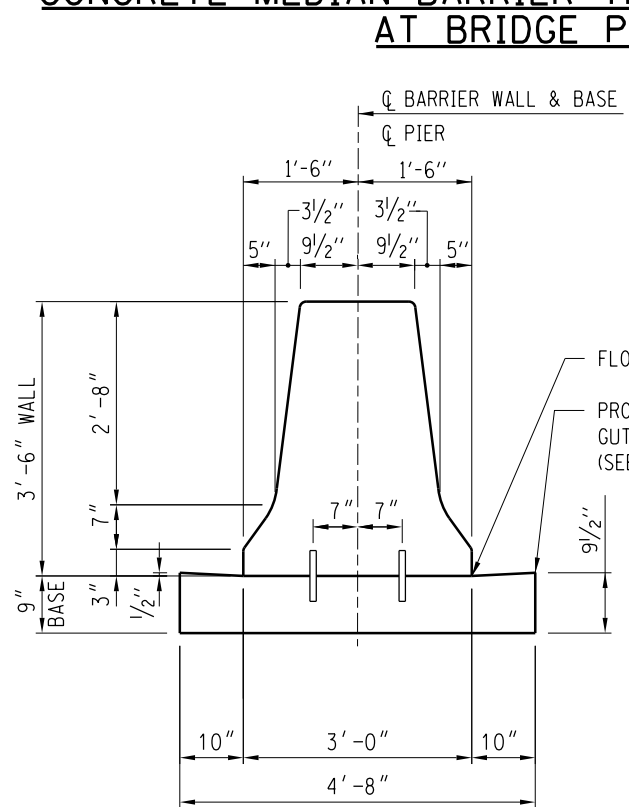

**SECTION A-A**

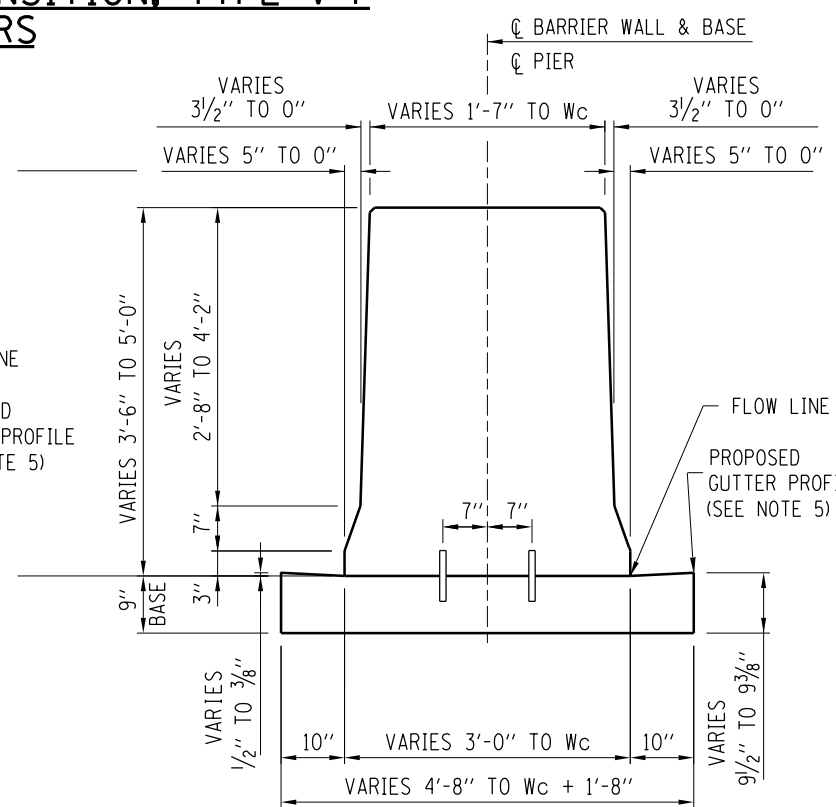

**SECTION B-B**

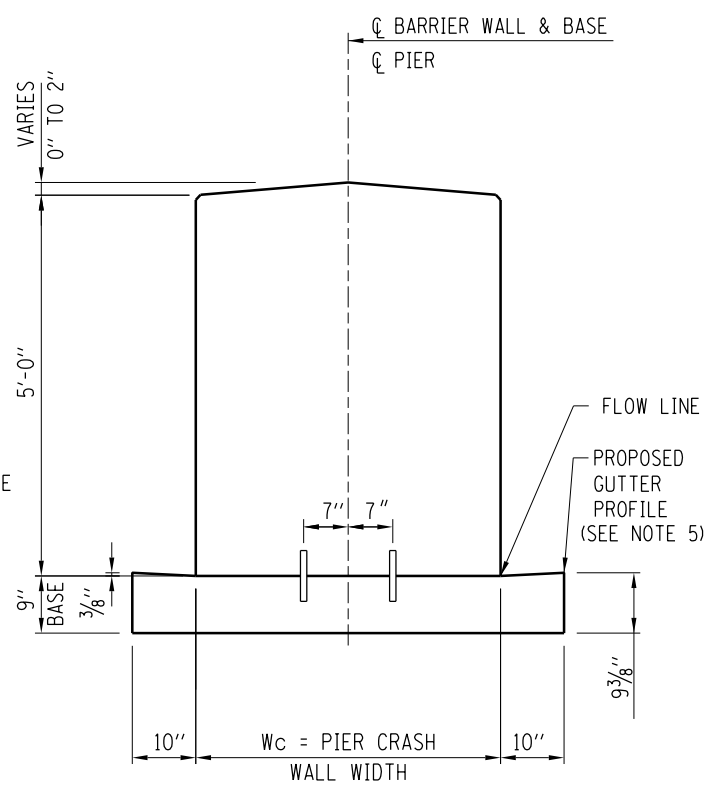

**SECTION C-C**

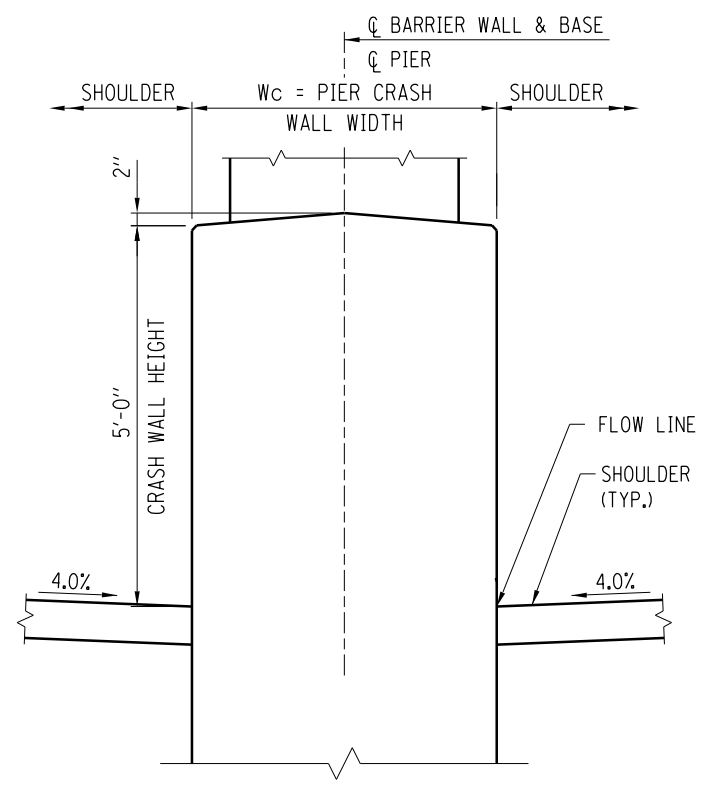

**SECTION D-D**

APPROVED *Paul Kovacs* CHIEF ENGINEER DATE 2-7-2012

DATE	REVISIONS
11-1-2012	MODIFIED MEDIAN BARRIER TRANSITION

**Illinois Tollway**  
Open Roads for a Faster Future

CONCRETE MEDIAN BARRIER TRANSITION, TYPE V-F AT BRIDGE PIERS

STANDARD C13-01