

Illinois Tollway Standard Drawing Revisions

Section F Sign Structure	
Standard	Modification Summary
	Effective: 03-31-2016
All	The electronic (pdf) version of the Standard Drawings are now made searchable (text).
F1 Overhead Sign Structure Span Type Structure Details	
Sheet 1	Added Note 5 to clarify that only sign panels are permitted on this truss.
Sheet 1	Revised fillet weld size in typical joint to 5/16" to allow for a smaller weld size.
Sheet 2	Updated Base Plate anchor bolt layout to avoid conflict with weld for 12" diameter columns.
Sheet 3	Revised Note 1 to clarify requirements for Contractor when soil conditions are not met in the field.
Sheet 3	Updated Base Plate anchor bolt layout to avoid conflict with weld for 12" diameter columns.
Sheet 3	Updated Notes to include material requirements for anchor bolts.
Sheet 4	Added note 5 to clarify limits of protective coat and added protective coat quantity to Design Table.
Sheet 4	Updated Base Plate anchor bolt layout to avoid conflict with weld for 12" diameter columns.
Sheet 5	Added protective coat quantity to Design Table.
Sheet 5	Updated Base Plate anchor bolt layout to avoid conflict with weld for 12" diameter columns.
Sheet 5	Added Section D-D to be consistent with sheet 4.
F4 Overhead Sign Structure Cantilever Type Structure Details	
Sheet 6	Revised Note 1 to clarify requirements for Contractor when soil conditions are not met in the field.
Sheet 6	Updated grade beam concrete class to DS concrete to be consistent with the Tollway Specifications.
Sheet 7	Added note 6 to clarify limits of protective coat and added protective coat quantity to Design Table.
F11 Milepost Marker	
Sheet 2	Removed note 8 to avoid confusion with the Standard Specification.
F13 Overhead Sign Structure Monotube Type (Steel) Mainline Structure Details	
Sheet 4	Updated anchor bolt note to allow AASHTO M314 bolts.
Sheet 6	Added note 3 to clarify limits of protective coat and added protective coat quantity to Estimated Quantity table.
Sheet 6	Revised Foundations Note to clarify requirements for Contractor when soil conditions are not met in the field.
Sheet 8	Single Face Barrier Elevation revised to clarify pay limits for Single Face Barrier and Foundation for Overhead Sign Structure.
Sheet 8	Section A-A and Section B-B were revised to clarify concrete class.
Sheet 8	Estimated Quantity table was revised to clarify concrete class and to add protective coat quantity.
F14 Overhead Sign Structure Butterfly Type Structure Details	
Sheet 1	Note 9 was revised to clarify that a Sign Panel is permitted to be installed on one face while a DMS Type 2 is installed on the other face of this truss.
Sheet 1	Removed all callouts, notes and details referencing the walkway grating and truss extension for walkway since the DMS Type 2 is front access and the walkway grating is not required for inspection of the DMS.
Sheet 1	Updated anchor bolt note to allow AASHTO M314 bolts.
Sheet 2	Removed all callouts, notes and details referencing the walkway grating since the DMS Type 2 is front access and the walkway grating is not required for inspection of the DMS.
Sheet 4	Updated anchor bolt note to allow AASHTO M314 bolts.
Sheet 5	Added note 2 to clarify limits of protective coat and added protective coat quantity to Bill of Material.
Sheet 5	Added Foundations Note to clarify requirements for Contractor when soil conditions are not met in the field.
Sheet 8	Removed all callouts, notes and details referencing the walkway grating and truss extension for walkway since the DMS Type 2 is front access and the walkway grating is not required for inspection of the DMS.
Sheet 8	Added Section B-B from previous Sheet 9.
Sheet 9	Sheet removed from standard.
Sheet 10	Sheet removed from standard.
F15 Overhead Sign Structure Monotube Type (Steel) Structure Details for AET Ramp	
Sheet 4	Updated Notes to include material requirements for anchor bolts.
Sheet 6	Revised Foundations Note to clarify requirements for Contractor when soil conditions are not met in the field.
Sheet 6	Added note 4 to clarify limits of protective coat and revised protective coat quantity in Estimated Quantity table.
Sheet 7	Single Face Barrier Elevation revised to clarify pay limits for Single Face Barrier and Foundation for Overhead Sign Structure.
Sheet 7	Estimated Quantity table was revised to clarify concrete class and to add protective coat quantity.
F16 Overhead Sign Structure Monotube Type (Steel) Structure Details for Cash-IPO Ramp	
Sheet 3	Updated Notes to include material requirements for anchor bolts.
Sheet 5	Revised Foundations Note to clarify requirements for Contractor when soil conditions are not met in the field.
Sheet 5	Added note 4 to clarify limits of protective coat and revised protective coat quantity in Estimated Quantity table.
Sheet 5	Side Elevation was revised to clarify concrete class.
Sheet 6	Single Face Barrier Elevation revised to clarify pay limits for Single Face Barrier and Foundation for Overhead Sign Structure.
Sheet 6	Section B-B were revised to clarify concrete class.
Sheet 6	Estimated Quantity table was revised to clarify concrete class and to revise protective coat quantity.
F17 Overhead Sign Structure Span Type (Steel) Structure Details	
Sheet 7	Revised Note 1 to clarify requirements for Contractor when soil conditions are not met in the field.
Sheet 8	Added note 5 to clarify limits of protective coat and added protective coat quantity to Median Barrier Foundation Schedule.
Sheet 9	Added note 5 to clarify limits of protective coat and added protective coat quantity to Median Barrier Foundation Schedule.

New Sheet

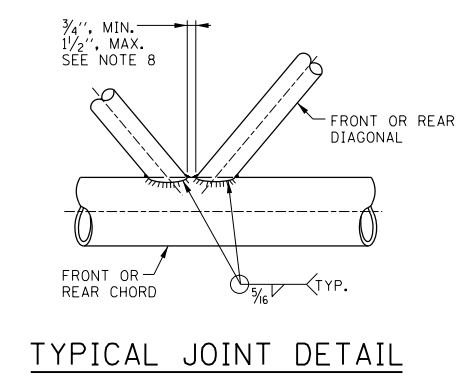
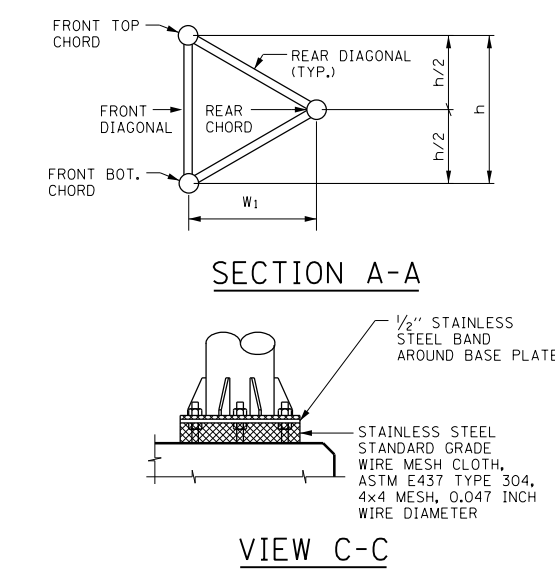
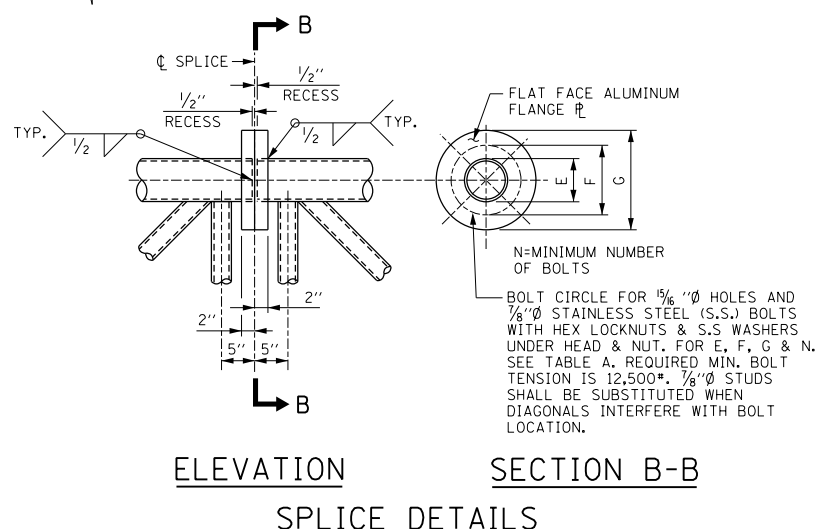
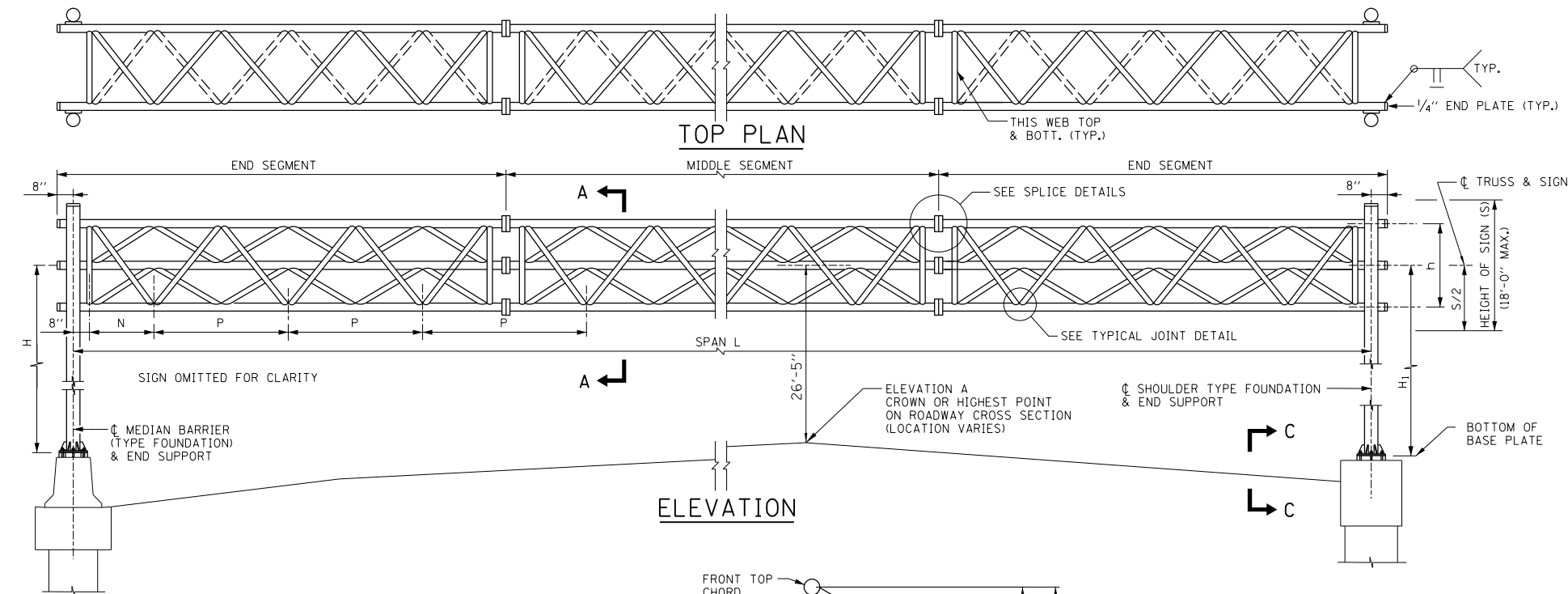

GENERAL NOTES:

1. WORK THIS SHEET WITH OVERHEAD SIGN STRUCTURES SPAN TYPE SUMMARY AND TOTAL BILL OF MATERIAL.
2. AFTER ADJUSTMENTS TO LEVEL TRUSS AND ENSURE ADEQUATE VERTICAL CLEARANCE, ALL TOP AND LEVELING NUTS SHALL BE TIGHTENED AGAINST THE BASE PLATE WITH A MINIMUM TORQUE OF 200 LB.-FT. STAINLESS STEEL MESH SHALL THEN BE PLACED AROUND THE PERIMETER OF THE BASE PLATE. SECURE TO BASE PLATE WITH STAINLESS STEEL BANDING.
3. SIGN SUPPORT STRUCTURES MAY BE SUBJECT TO DAMAGING VIBRATIONS AND OSCILLATIONS WHEN SIGN PANELS ARE NOT IN PLACE DURING ERECTION OR MAINTENANCE OF THE STRUCTURE. TO AVOID THESE, ATTACH TEMPORARY BLANK SIGN PANELS OR OTHER BRACING TO THE STRUCTURE UNTIL PERMANENT SIGNS ARE INSTALLED.
4. TRUSS SEGMENTS SHALL BE SHIPPED INDIVIDUALLY WITH ADEQUATE PROVISION TO PREVENT DETRIMENTAL MOTION DURING TRANSPORT. THE CONTRACTOR IS RESPONSIBLE FOR MAINTAINING THE CONFIGURATION AND PROTECTION OF THE TRUSSES.
5. ONLY SIGN PANELS ARE PERMITTED TO BE MOUNTED ON THIS TRUSS.

DESIGN SPECIFICATIONS:

1. 2013 AASHTO STANDARD SPECIFICATIONS FOR STRUCTURAL SUPPORTS FOR HIGHWAY SIGNS, LUMINAIRES AND TRAFFIC SIGNALS, 6TH EDITION.

CONSTRUCTION SPECIFICATIONS:

1. ALL MATERIALS, EXCEPT AS SHOWN, FABRICATION, ERECTION AND CONSTRUCTION REQUIREMENTS SHALL BE IN ACCORDANCE WITH SECTION 733 OF THE LATEST ILLINOIS TOLLWAY SUPPLEMENTAL SPECIFICATIONS.
2. THE COST OF FURNISHING AND INSTALLATION THE STAINLESS STEEL BAND AND WIRE MESH CLOTH IS INCLUDED IN THE COST OF OVERHEAD SIGN STRUCTURE SPAN TYPE.

LOADING:

1. BOTH END SUPPORTS ARE DESIGNED FOR 60% OF THE TOTAL LOAD.
2. WIND LOADING SHALL BE A MINIMUM OF 35 PSF ON SIGN PANELS AND 10 PSF ON GROSS AREAS DEFINED BY THE PERIMETER OF TRUSS MEMBERS NOT COVERED BY SIGN PANEL AREAS.
3. THE AASHTO GROUP II AND III ALLOWABLE STRESS SHALL BE 133% (ALLOWABLE STRESS DESIGN).

FABRICATION NOTES:

1. NO SPLICES SHALL BE LOCATED WITHIN 0.1xL OF THE CENTERLINE OF THE SPAN.
2. MATERIALS: ALUMINUM SHALL CONFORM TO ASTM B221, ALLOY 6061 TEMPER T6. ALL STRUCTURAL STEEL PIPE SHALL BE ASTM A53 GRADE B OR A106 GRADE B. ALL STRUCTURAL STEEL PLATES AND SHAPES SHALL CONFORM TO AASHTO M270 GR. 36 OR GR. 50. STAINLESS STEEL FOR SHIMS, SLEEVES AND HANDHOLE COVERS SHALL BE ASTM A240, TYPE 302 OR 304, OR ANOTHER ALLOY SUITABLE FOR EXTERIOR EXPOSURE AND ACCEPTABLE TO THE ENGINEER. THE STEEL PIPE AND STIFFENING RIBS AT THE BASE PLATE FOR THE COLUMN SHALL HAVE A MINIMUM LONGITUDINAL CHARPY V-NOTCH (CVN) ENERGY OF 15 LB.-FT. AT 40° F. (ZONE 2) BEFORE GALVANIZING.
3. WELDING: ALL WELDS TO BE CONTINUOUS UNLESS OTHERWISE SHOWN. ALL WELDING TO BE DONE IN ACCORDANCE WITH CURRENT AWS D1.1 AND D1.2 STRUCTURAL WELDING CODES (STEEL AND ALUMINUM) AND THE STANDARD SPECIFICATIONS. ALUMINUM WELD FILLER SHALL BE ALLOY 5556.
4. FASTENERS FOR ALUMINUM TRUSSES: HIGH STRENGTH BOLTS MUST SATISFY THE REQUIREMENTS OF AASHTO M164 (ASTM A325), OR APPROVED ALTERNATE, AND MUST HAVE MATCHING LOCK NUTS. THREADED STUDS FOR SPLICES (IF MEMBERS INTERFERE) MUST SATISFY THE REQUIREMENTS OF ASTM A449, ASTM A193, GRADE B7, OR APPROVED ALTERNATE, AND MUST HAVE MATCHING LOCK NUTS. BOLTS AND LOCK NUTS NOT REQUIRED TO BE HIGH STRENGTH MUST SATISFY THE REQUIREMENTS OF ASTM A307. ALL BOLTS AND LOCK NUTS MUST BE HOT DIP GALVANIZED PER AASHTO M232, EXCEPT STAINLESS STEEL FASTENERS, NUTS AND WASHERS. THE LOCK NUTS MUST HAVE NYLON OR STEEL INSERTS. A STAINLESS STEEL FLAT WASHER CONFORMING TO ASTM A240 TYPE 302 OR 304, IS REQUIRED UNDER BOTH HEAD AND NUT OR UNDER BOTH NUTS WHERE THREADED STUDS ARE USED. HIGH STRENGTH BOLT INSTALLATION SHALL CONFORM TO ARTICLE 505.04 (F) (2) OF THE IDOT STANDARD SPECIFICATIONS FOR ROAD AND BRIDGE CONSTRUCTION. ROTATIONAL CAPACITY ("ROCAP") TESTING OF BOLTS WILL NOT BE REQUIRED.
5. U-BOLTS: U-BOLTS MUST BE PRODUCED FROM ASTM A276 TYPE 304, 304L, 316 OR 316L, CONDITION A, COLD FINISHED STAINLESS STEEL, OR AN EQUIVALENT MATERIAL ACCEPTABLE TO THE ENGINEER. ALL NUTS FOR U-BOLTS MUST BE LOCK NUTS EQUIVALENT TO ASTM A307 WITH NYLON OR STEEL INSERTS AND HOT DIP GALVANIZED PER AASHTO M232. A STAINLESS STEEL FLAT WASHER CONFORMING TO ASTM A240, TYPE 302 OR 304, IS REQUIRED UNDER EACH U-BOLT LOCK NUT.
6. GALVANIZING: ALL STEEL GRATING, PLATES, SHAPES AND PIPE SHALL BE HOT DIP GALVANIZED AFTER FABRICATION IN ACCORDANCE WITH AASHTO M111. PAINTING IS NOT PERMITTED.
7. SEE TABLE "SIGN STRUCTURE MEMBER SCHEDULE" FOR "W" AND "W1".
8. DIAGONALS SHALL BE DETAILED TO MINIMIZE OFFSET FOR THEORETICAL PANEL POINT AND PROVIDE 3/4 TO 1/2 INCH CLEARANCE BETWEEN DIAGONALS AND PROVIDE CLEARANCE FOR U-BOLT CONNECTIONS OF SIGNS OR WALKWAY BRACKETS.

SIGN STRUCTURE MEMBER SCHEDULE

TRUSS NO.	DIMENSIONS						ALUMINUM TRUSS				STEEL END SUPPORT				
	TRUSS SPAN L	P	N	h	W ₁	MAXIMUM ALLOWABLE SIGN PANEL AREA	DL (TRUSS) DEFLECTION	MIDDLE SEGMENT OR END SEGMENT				PIPE COLUMN (NOMINAL DIAMETER)			
								CHORD (O.D.)		DIAGONAL (O.D.)		10" X.X.S. (104.13#/FT.)		12" X.X.S. (125.49#/FT.)	
								FRONT	REAR	FRONT	REAR	H OR H ₁	H OR H ₁	H OR H ₁	H OR H ₁
T-80	80'-0"	9'-0"	3'-4"	4'-6"	3'-10 3/4"	900 S.F.	1"	5 1/2" φ x 1/2"	5 1/2" φ x 1/2"	2 1/2" φ x 1/4"	2 1/2" φ x 1/4"	5'-8"	32'-0" (MAX)	38'-0" (MAX)	
T-85	85'-0"	9'-6"	3'-10"	4'-9"	4'-1 3/8"	955 S.F.	1 1/16"	6 7/8" φ x 1/2"	6 7/8" φ x 1/2"	3" φ x 1/4"	3" φ x 1/4"	6'-4"	31'-0" (MAX)	38'-0" (MAX)	
T-90	90'-0"	10'-0"	4'-4"	5'-0"	4'-4"	1010 S.F.	1 1/8"	6 7/8" φ x 1/2"	6 7/8" φ x 1/2"	3" φ x 1/4"	3" φ x 1/4"	6'-4"	31'-0" (MAX)	38'-0" (MAX)	
T-95	95'-0"	10'-6"	4'-10"	5'-3"	4'-6 5/8"	1065 S.F.	1 3/16"	6 7/8" φ x 1/2"	6 7/8" φ x 1/2"	3" φ x 1/4"	3" φ x 1/4"	6'-4"	31'-0" (MAX)	38'-0" (MAX)	
T-100	100'-0"	11'-4"	4'-0"	5'-8"	4'-10 7/8"	1125 S.F.	1 1/4"	7" φ x 1/2"	7" φ x 1/2"	3 1/2" φ x 1/4"	3 1/2" φ x 1/4"	7'-4"	31'-0" (MAX)	38'-0" (MAX)	
T-105	105'-0"	12'-0"	3'-10"	6'-0"	5'-2 3/8"	1180 S.F.	1 5/16"	7" φ x 1/2"	7" φ x 1/2"	3 1/2" φ x 1/4"	3 1/2" φ x 1/4"	7'-4"	31'-0" (MAX)	38'-0" (MAX)	
T-110	110'-0"	12'-6"	4'-4"	6'-3"	5'-5"	1200 S.F.	1 3/8"	7" φ x 1/2"	7" φ x 1/2"	3 1/2" φ x 1/4"	3 1/2" φ x 1/4"	7'-4"	31'-0" (MAX)	38'-0" (MAX)	
T-115	115'-0"	13'-0"	4'-10"	6'-6"	5'-7 5/8"	1200 S.F.	1 1/2"	7 1/2" φ x 1/2"	7 1/2" φ x 1/2"	3 1/2" φ x 1/4"	3 1/2" φ x 1/4"	10'-2"	34'-0" (MAX)	40'-0" (MAX)	
T-120	120'-0"	13'-8"	4'-8"	6'-10"	5'-11"	1200 S.F.	1 5/16"	7 1/2" φ x 1/2"	7 1/2" φ x 1/2"	3 1/2" φ x 1/4"	3 1/2" φ x 1/4"	10'-2"	34'-0" (MAX)	40'-0" (MAX)	
T-130	130'-0"	15'-0"	4'-4"	7'-6"	6'-5 3/8"	1200 S.F.	1 5/16"	9" φ x 1/2"	9" φ x 1/2"	4" φ x 1/4"	4" φ x 1/4"	10'-2"	NOT APPLICABLE	40'-0" (MAX)	
T-140	140'-0"	16'-3"	4'-4"	8'-2"	7'-0 7/8"	1200 S.F.	1 1/16"	10" φ x 1/2"	10" φ x 1/2"	4" φ x 1/4"	4" φ x 1/4"	10'-2"	NOT APPLICABLE	40'-0" (MAX)	
T-150	150'-0"	17'-6"	4'-4"	8'-10"	7'-7 3/4"	1200 S.F.	1 3/16"	11" φ x 1/2"	11" φ x 1/2"	4 1/2" φ x 1/4"	4 1/2" φ x 1/4"	10'-2"	NOT APPLICABLE	40'-0" (MAX)	

CAMBER	
SPAN IN FEET	CAMBER IN INCHES
80 THRU 95	1 1/2"
96 THRU 110	1 5/8"
111 THRU 120	1 7/8"
121 THRU 130	1 7/8"
131 THRU 140	2"
141 THRU 150	2 1/8"

TABLE A			
CHORD O.D.	E	F	N
5 1/2" φ	10"	13"	8
6 7/8" φ & 7" φ	11 1/2"	14 1/2"	10
7 1/2" φ	12 1/2"	15 1/2"	12
9" φ	13 1/2"	16 1/2"	14
10" φ	15 1/2"	18 1/2"	16
11" φ	17 1/2"	20 1/2"	18

PROVIDE THE ABOVE CAMBER AT MIDDLE OF SPAN OF STRUCTURES

DATE	REVISIONS
2-07-2012	REVISED FOUNDATIONS AND REVISED NOTES.
2-01-2013	REVISED TABLES, ELEVATION, AND NOTES.
12-12-2013	REVISED TABLES AND NOTES.
3-31-2014	REVISED SIGN STRUCTURE DETAILS.
7-01-2014	REVISED FOUNDATION CONCRETE.
3-11-2015	REVISED NOTES.
3-31-2016	REVISED FOUNDATION NOTE AND REVISED BASE PLATE DIMENSIONS.

NOTES:

1. XXS DENOTES DOUBLE EXTRA STRONG PIPE.
2. A PAIR OF MAIN PIPE COLUMN SIZES FOR EACH SUPPORT SHALL BE SELECTED INDEPENDENTLY BASED ON SPECIFIC NEEDS.

APPROVED: *Paul Kovacs* CHIEF ENGINEER DATE 2-7-2012



OVERHEAD SIGN STRUCTURE SPAN TYPE STRUCTURE DETAILS

STANDARD F1-06

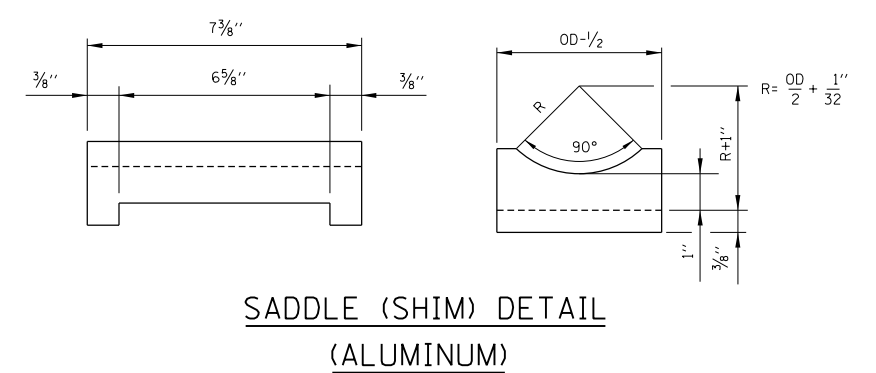
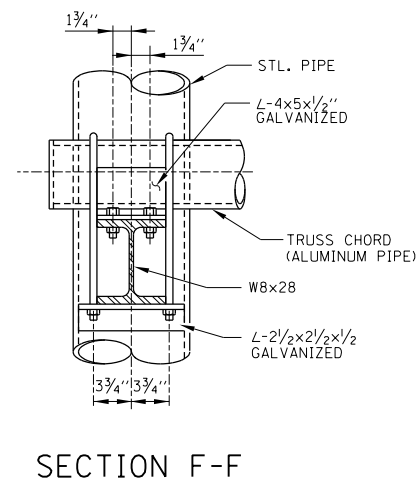
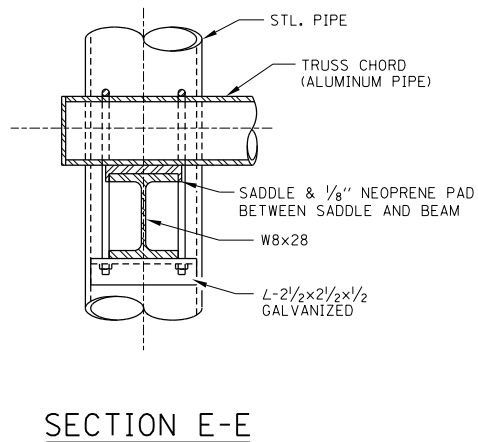
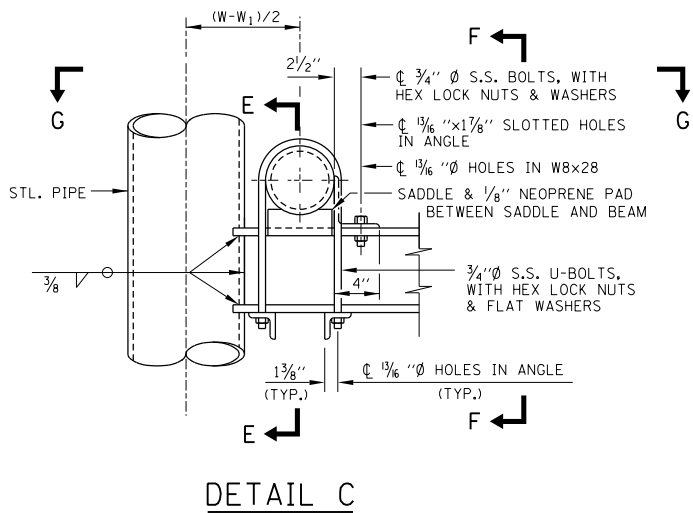
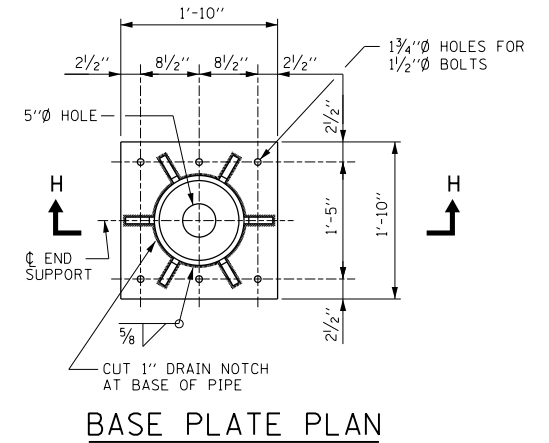
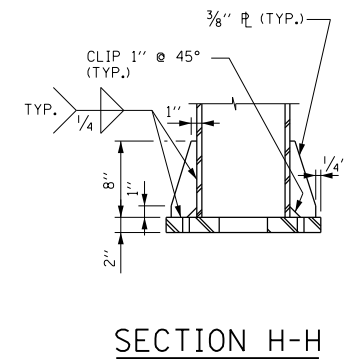
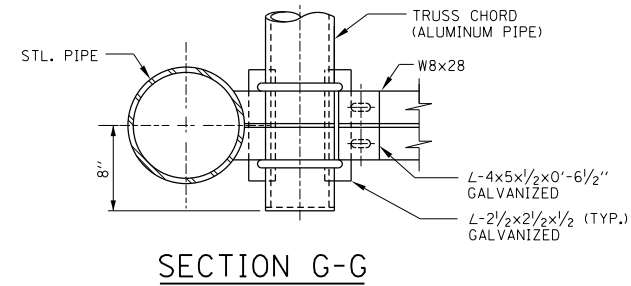
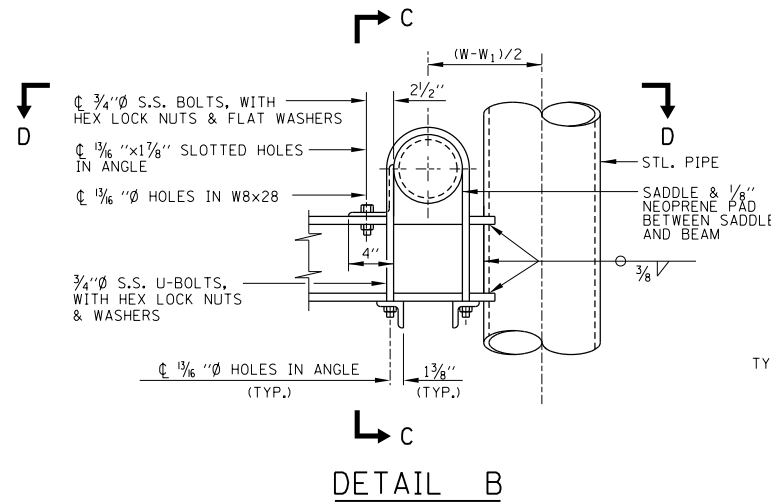
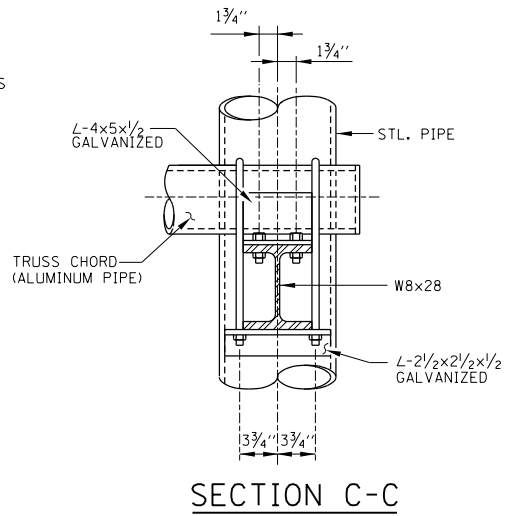
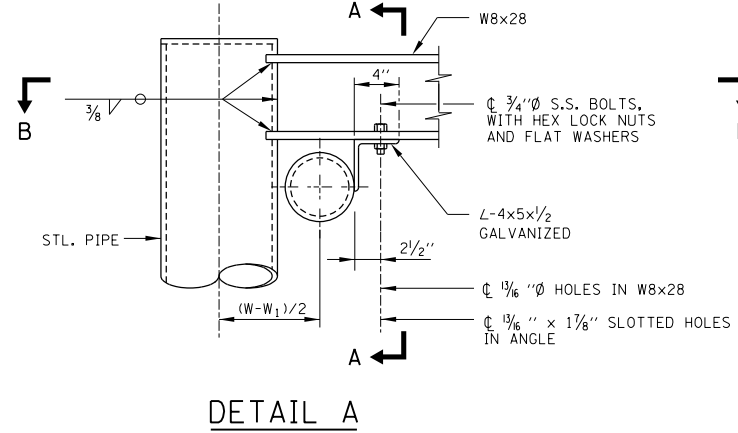
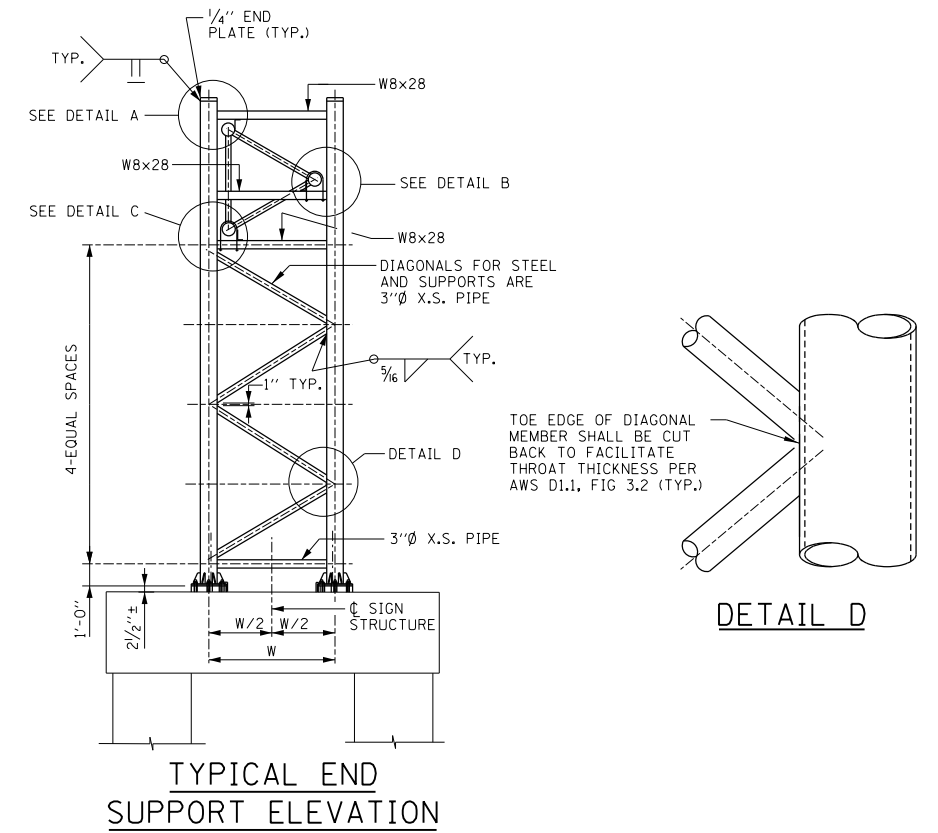
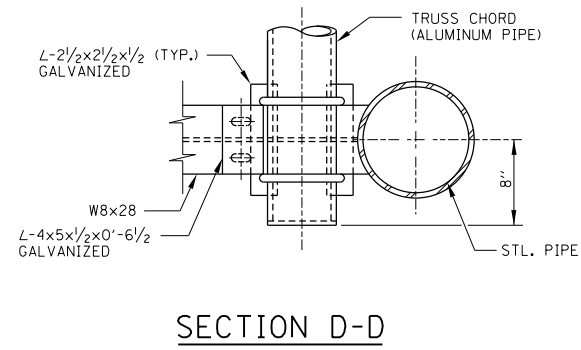
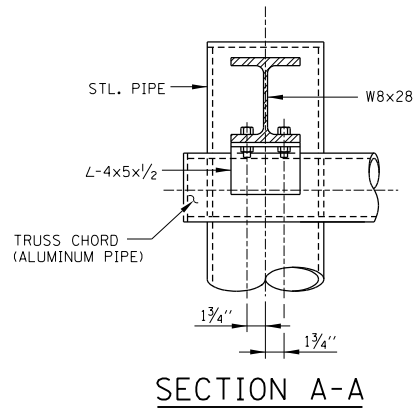
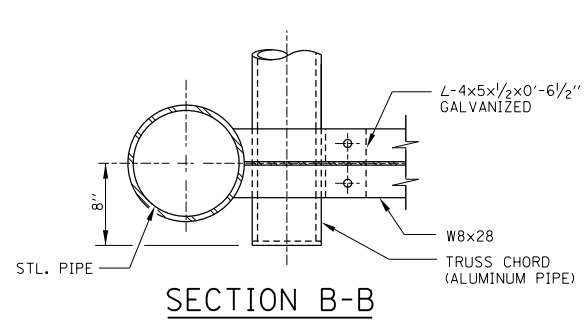

Paul Kovacs
APPROVED... CHIEF ENGINEER... DATE 2-7-2012

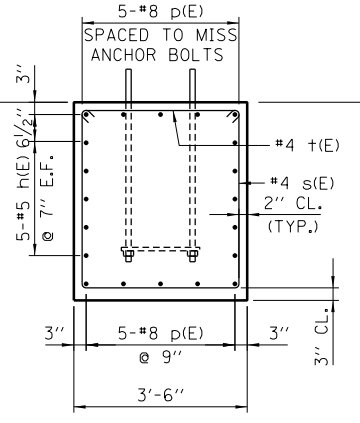
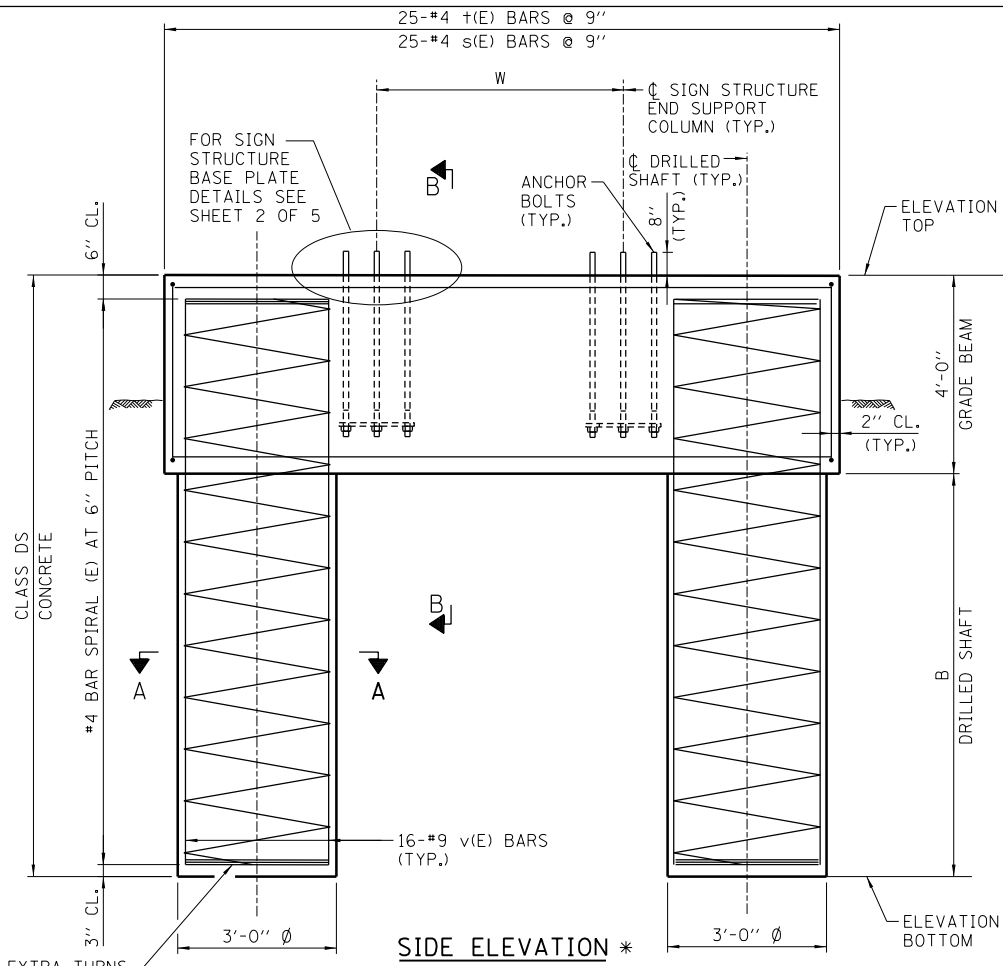

SECTION B-B
* REINFORCEMENT IN GRADE BEAM NOT SHOWN FOR CLARITY

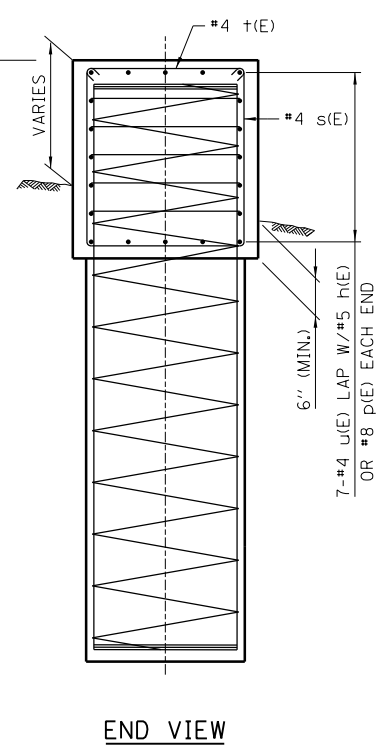
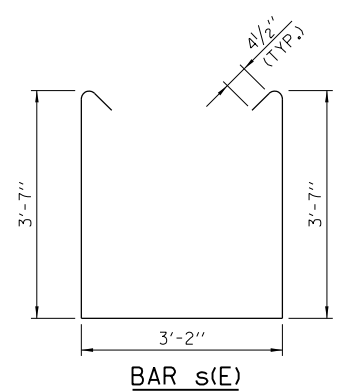

END VIEW

NOTES:

1. THE FOUNDATION DETAILS SHOWN ARE BASED ON THE PRESENCE OF MOSTLY COMMON COHESIVE SOIL CONDITIONS (SILTY OR SANDY CLAY), WITH AN AVERAGE UNCONFINED COMPRESSIVE STRENGTH (QU) > 1.25 TON/SQ. FT. WHICH MUST BE DETERMINED BY PREVIOUS SOIL INVESTIGATIONS AT THE JOBSITE. WHEN OTHER CONDITIONS ARE INDICATED, THE FOUNDATION DIMENSIONS SHOWN SHALL BE INCLUDED IN THE PLANS AND THE FOUNDATION DIMENSIONS SHOWN SHALL BE THE RESULT OF SITE SPECIFIC DESIGNS. IF CONDITIONS ENCOUNTERED IN THE FIELD ARE DIFFERENT THAN THOSE INDICATED, THE CONTRACTOR SHALL NOTIFY THE ENGINEER TO DETERMINE IF THE FOUNDATION DIMENSIONS NEED TO BE MODIFIED.
2. ANCHOR BOLTS SHALL CONFORM TO THE REQUIREMENTS OF AASHTO M314 OR ASTM F1554 GRADE 55, WITH A MINIMUM TENSILE STRENGTH OF 75,000 PSI. ALL OTHER MATERIAL, FABRICATION, AND CONSTRUCTION REQUIREMENTS SHALL BE IN ACCORDANCE WITH SECTION 734 OF THE ILLINOIS TOLLWAY SUPPLEMENTAL SPECIFICATIONS.
3. CONCRETE SHALL BE PLACED MONOLITHICALLY, WITHOUT CONSTRUCTION JOINTS UNLESS NOTED OTHERWISE.
4. BACKFILL SHALL BE PLACED PER SECTION 502 OF THE IDOT STANDARD SPECIFICATION AND PRIOR TO ERECTION OF SUPPORT COLUMN.
5. A NORMAL SURFACE FINISH FOLLOWED BY A CONCRETE SEALER APPLICATION WILL BE REQUIRED ON CONCRETE SURFACES ABOVE THE LOWEST ELEVATION 6" BELOW FINISHED GROUND LINE. COST INCLUDED IN THE COST OF THE FOUNDATION.
6. ALL REBAR DESIGNATED (E) SHALL BE EPOXY COATED. REBAR SHALL BE POSITIONED SO THAT THERE WILL BE NO INTERFERENCE BETWEEN VERTICAL REINFORCEMENT AND ANCHOR BOLTS.
7. SITE GROUNDING ELECTRODE SYSTEM TO BE PROVIDED AS INDICATED ON THE PLANS.
8. NO SONOTUBES OR DECOMPOSABLE FORMS SHALL BE USED 6" BELOW THE FINISHED GROUND LINE. PERMANENT METAL FORMS OR OTHER SHIELDING MAY NOT BE LEFT IN PLACE BELOW THE ELEVATION WITHOUT THE ENGINEER'S WRITTEN PERMISSION. EXCAVATIONS SHALL BE DEWATERED BEFORE CONCRETE PLACEMENT IF DIRECTED BY THE ENGINEER AT NO ADDITIONAL COST.
9. IF NECESSARY TO INCREASE STEEL END SUPPORT HEIGHT ABOVE THE LIMITATIONS SHOWN IN SIGN STRUCTURE MEMBER SCHEDULE ON SHEET 1 OF THIS SERIES, GRADE BEAM DEPTH MAY BE INCREASED UP TO 6'-0" WITHOUT CHANGES TO THE DRILLED SHAFT DESIGN. GRADE BEAM REINFORCEMENT, CONCRETE VOLUME AND LENGTH OF ANCHOR BOLTS SHALL BE REVISED ACCORDINGLY.

DESIGN TABLE FOR DRILLED SHAFTS IN COHESIVE SOILS					
TRUSS No.	W	X	B	CLASS DS CONC. CY	REINF. BARS POUND
T-80	5'-8"	4'-5"	40'-0"	30.3	6620
T-85	6'-4"	4'-1"	50'-0"	35.5	7910
T-90	6'-4"	4'-1"	50'-0"	35.5	7910
T-95	6'-4"	4'-1"	50'-0"	35.5	7910
T-100	7'-4"	3'-7"	50'-0"	35.5	7910
T-105	7'-4"	3'-7"	50'-0"	35.5	7910
T-110	7'-4"	3'-7"	50'-0"	35.5	7910
T-115	10'-2"	2'-2"	50'-0"	35.5	7910
T-120	10'-2"	2'-2"	50'-0"	35.5	7910
T-130	10'-2"	2'-2"	55'-0"	38.1	8560
T-140	10'-2"	2'-2"	55'-0"	38.1	8560
T-150	10'-2"	2'-2"	55'-0"	38.1	8560

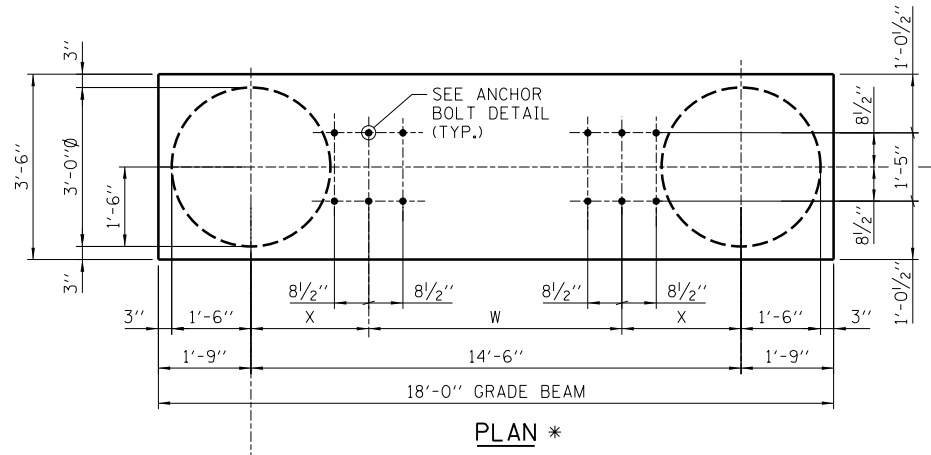

PLAN *

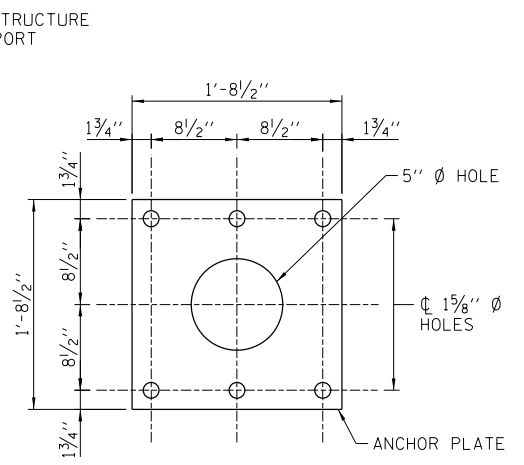

SECTION C-C

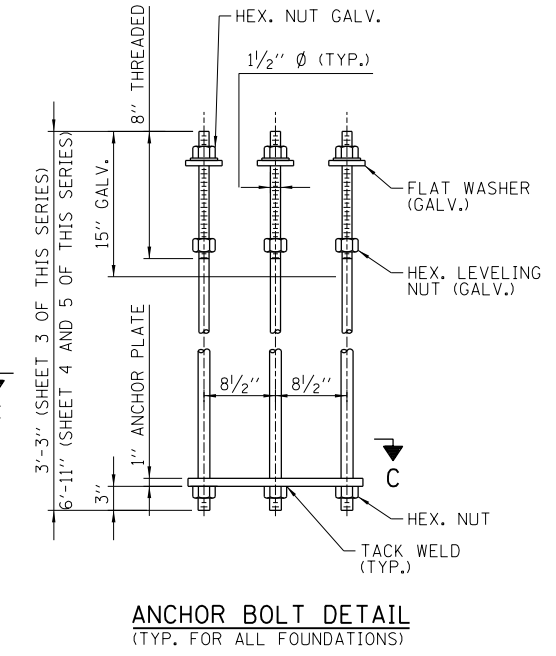

ANCHOR BOLT DETAIL
(TYP. FOR ALL FOUNDATIONS)

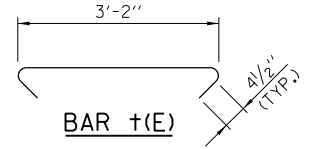

BAR + (E)

BAR LIST - EACH FOUNDATION
(2 SHAFT AND 1 GRADE BEAM)

BAR	NUMBER	SIZE	LENGTH	SHAPE
h (E)	10	#5	17'-8"	—
p (E)	10	#8	17'-8"	—
s (E)	25	#4	11'-1"	U
t (E)	25	#4	3'-11"	U
u (E)	14	#4	7'-0"	U
v (E)	32	#9	F LESS 9"	—

*4 BAR SPIRAL (E) - SEE SIDE ELEVATION

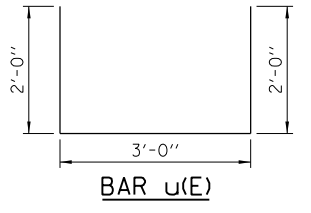

BAR u (E)

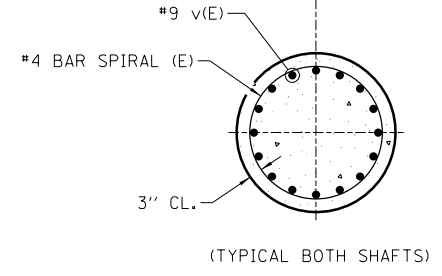

(TYPICAL BOTH SHAFTS)

APPROVED: *Paul Kovacs* CHIEF ENGINEER DATE 2-7-2012

SHEET 3 OF 5

OVERHEAD SIGN STRUCTURE
SPAN TYPE
STRUCTURE DETAILS

STANDARD F1-06

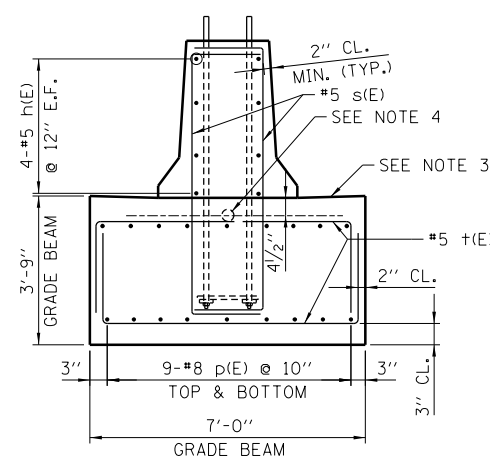
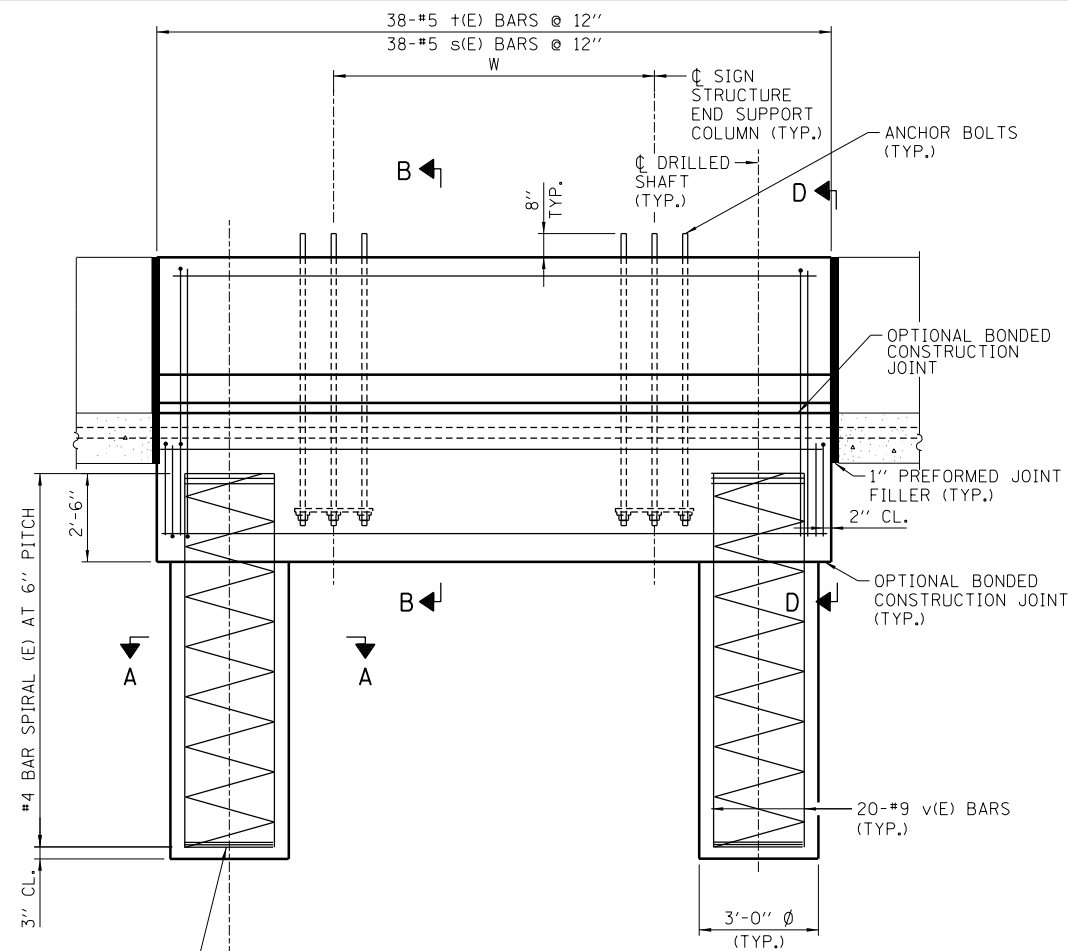

SECTION B-B

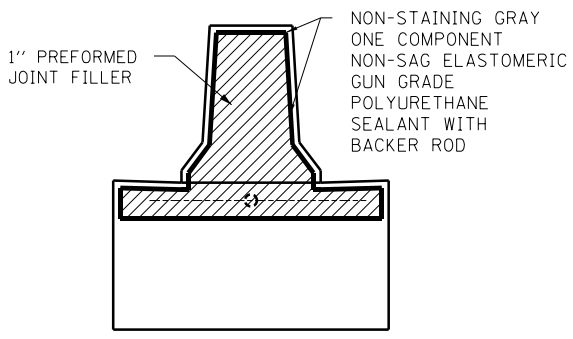

SECTION D-D

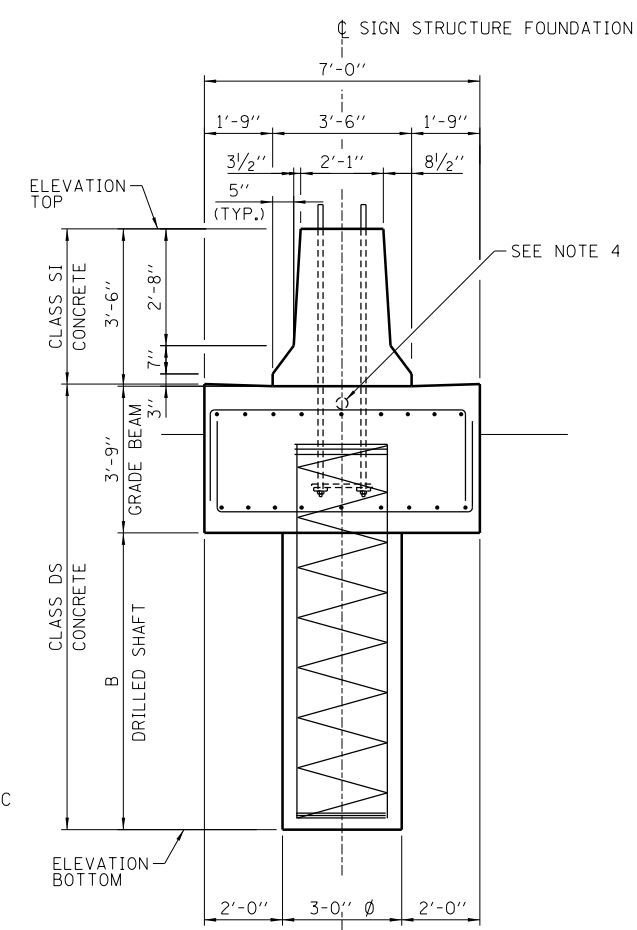

END VIEW

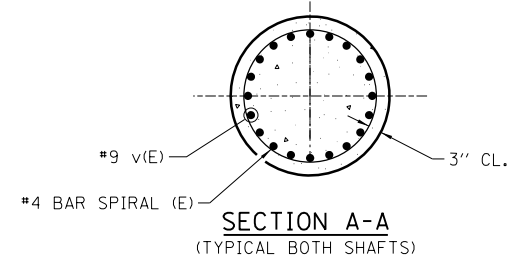

SECTION A-A
(TYPICAL BOTH SHAFTS)

BAR LIST - EACH FOUNDATION

BAR	NUMBER	SIZE	LENGTH	SHAPE
h(E)	8	#5	17'-8"	—
p(E)	18	#8	17'-8"	—
s(E)	38	#5	10'-1"	C
t(E)	38	#5	11'-10"	U
v(E)	40	#9	B ADD 2'-3"	—

#4 BAR SPIRAL (E) - SEE SIDE ELEVATION

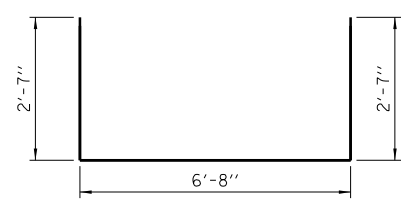

BAR t(E)

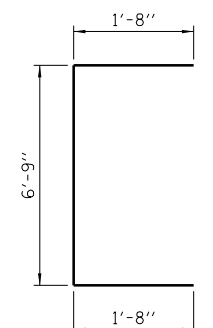

BAR s(E)

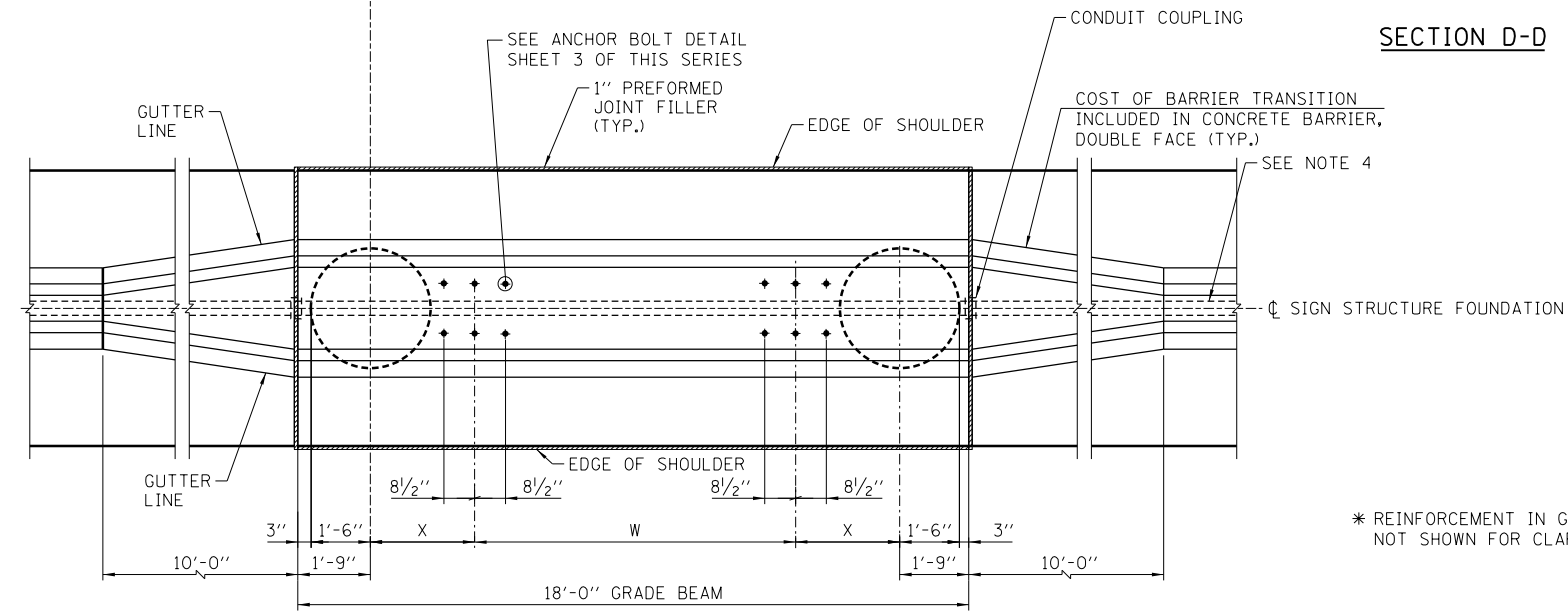

PLAN *

(REINFORCEMENT NOT SHOWN FOR CLARITY)

* REINFORCEMENT IN GRADE BEAM NOT SHOWN FOR CLARITY

DESIGN TABLE FOR DRILLED SHAFTS IN COHESIVE SOILS

TRUSS No.	W	X	B	CLASS DS CONC. CU. YD.	CLASS S1 CONC. CU. YD.	REINF. BARS POUND	PROTECTIVE COAT SQ. YD.
T-80	5'-8"	4'-5"	50'-0"	43.7	6.0	10100	26.0
T-85	6'-4"	4'-1"	55'-0"	46.3	6.0	10880	26.0
T-90	6'-4"	4'-1"	55'-0"	46.3	6.0	10880	26.0
T-95	6'-4"	4'-1"	55'-0"	46.3	6.0	10880	26.0
T-100	7'-4"	3'-7"	55'-0"	46.3	6.0	10880	26.0
T-105	7'-4"	3'-7"	55'-0"	46.3	6.0	10880	26.0
T-110	7'-4"	3'-7"	55'-0"	46.3	6.0	10880	26.0
T-115	10'-2"	2'-2"	55'-0"	46.3	6.0	10880	26.0
T-120	10'-2"	2'-2"	55'-0"	46.3	6.0	10880	26.0
T-130	10'-2"	2'-2"	55'-0"	46.3	6.0	10880	26.0
T-140	10'-2"	2'-2"	55'-0"	46.3	6.0	10880	26.0
T-150	10'-2"	2'-2"	55'-0"	46.3	6.0	10880	26.0

NOTES:

- SEE SHEET 3 OF THIS SERIES FOR GENERAL NOTES AND DESIGN CRITERIA.
- FOR SIGN STRUCTURE BASE PLATE DETAIL, SEE SHEET 2 OF THIS SERIES.
- REFERENCE ILLINOIS TOLLWAY STANDARD DRAWING C5 FOR GUTTER SLOPE.
- COORDINATE CONDUIT SIZE, LOCATION AND QUANTITY WITH ELECTRICAL PLANS, CONDUITS SHALL BE PLACED TO MISS REINFORCEMENT BARS, DO NOT CUT REINFORCEMENT BARS.
- PROTECTIVE COAT SHALL BE APPLIED TO THE TRAFFIC AND TOP FACES OF THE BARRIER AND TOP FACE OF GUTTER.



OVERHEAD SIGN STRUCTURE
SPAN TYPE
STRUCTURE DETAILS

STANDARD F1-06

APPROVED: *Paul Kovacs*
CHIEF ENGINEER DATE 2-7-2012

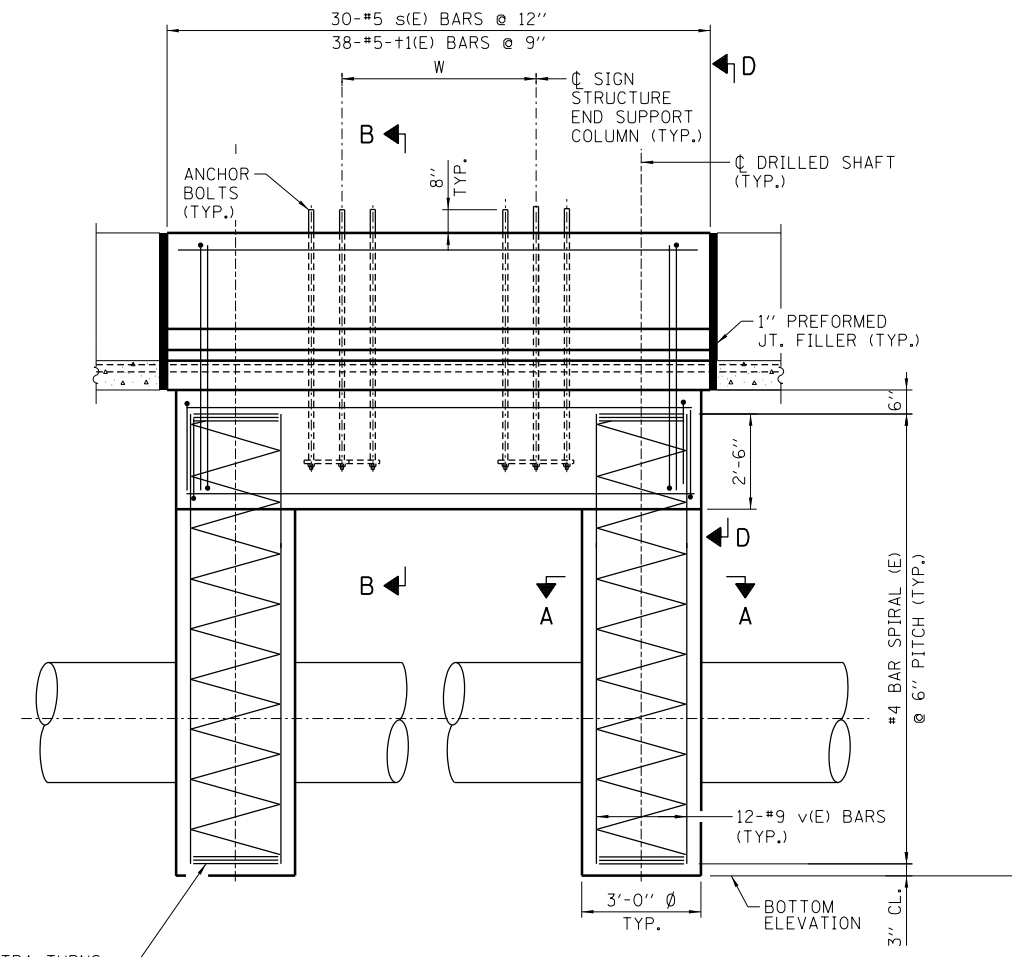

SIDE ELEVATION *

* REINFORCEMENT IN GRADE BEAM NOT SHOWN FOR CLARITY

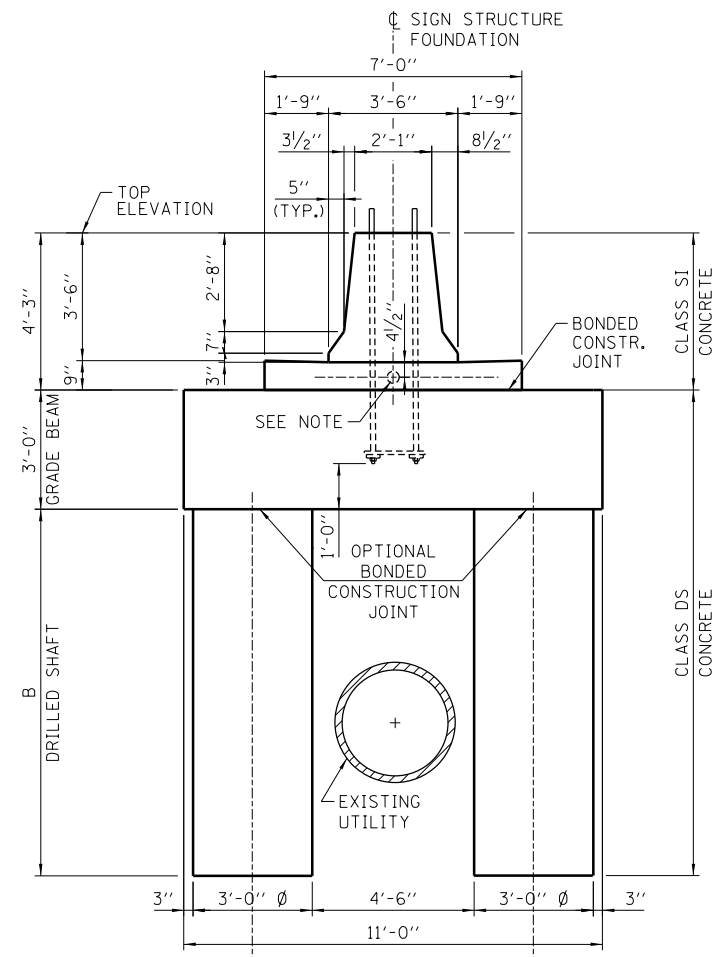

END VIEW

DESIGN TABLE FOR DRILLED SHAFTS IN COHESIVE SOILS

TRUSS No.	W	X	B	CLASS DS CONC. CU. YD.	CLASS SI CONC. CU. YD.	REINF. BARS POUND	PROTECTIVE COAT SQ. YD.
T-80	5'-8"	2'-5"	25'-0"	43.3	7.4	9030	21.0
T-85	6'-4"	2'-1"	25'-0"	43.3	7.4	9030	21.0
T-90	6'-4"	2'-1"	25'-0"	43.3	7.4	9030	21.0
T-95	6'-4"	2'-1"	25'-0"	43.3	7.4	9030	21.0
T-100	7'-4"	1'-7"	25'-0"	43.3	7.4	9030	21.0
T-105	7'-4"	1'-7"	30'-0"	48.5	7.4	10050	21.0
T-110	7'-4"	1'-7"	30'-0"	48.5	7.4	10050	21.0
T-115	10'-2"	0'-2"	30'-0"	48.5	7.4	10050	21.0
T-120	10'-2"	0'-2"	30'-0"	48.5	7.4	10050	21.0
T-130	10'-2"	0'-2"	30'-0"	48.5	7.4	10050	21.0
T-140	10'-2"	0'-2"	30'-0"	48.5	7.4	10050	21.0
T-150	10'-2"	0'-2"	30'-0"	48.5	7.4	10050	21.0

BAR LIST - EACH FOUNDATION

BAR	NUMBER	SIZE	LENGTH	SHAPE
h(E)	16	#5	13'-8"	—
p(E)	30	#8	13'-8"	—
s(E)	30	#5	10'-1"	C
t(E)	15	#5	6'-8"	—
t1(E)	38	#8	15'-10"	—
v(E)	48	#9	B ADD 2'-3"	—

#4 BAR SPIRAL (E) - SEE SIDE ELEVATION

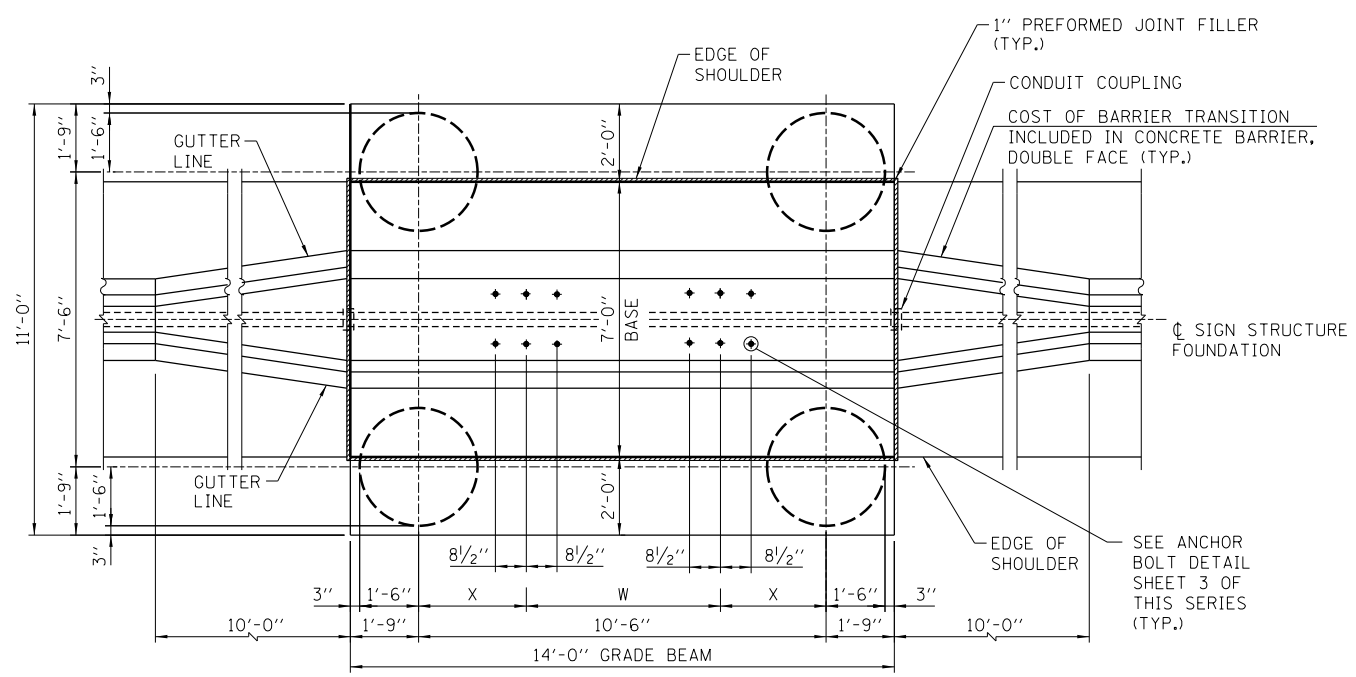

PLAN *

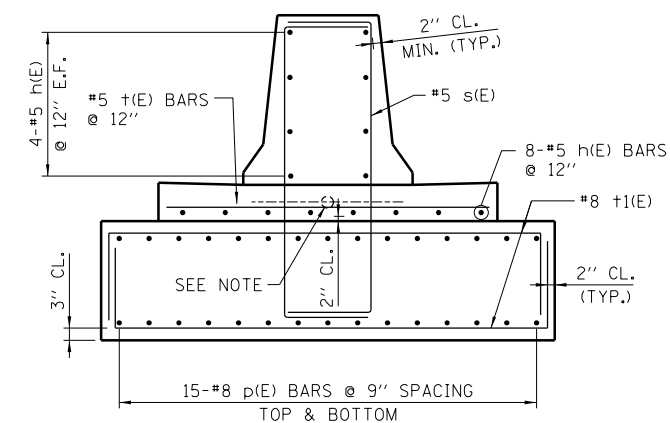

SECTION B-B

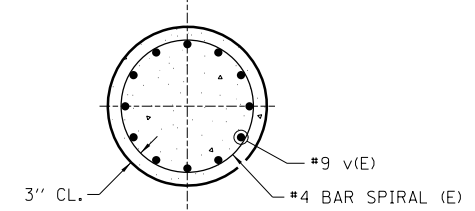

SECTION A-A
(TYPICAL FOR 4 SHAFTS)

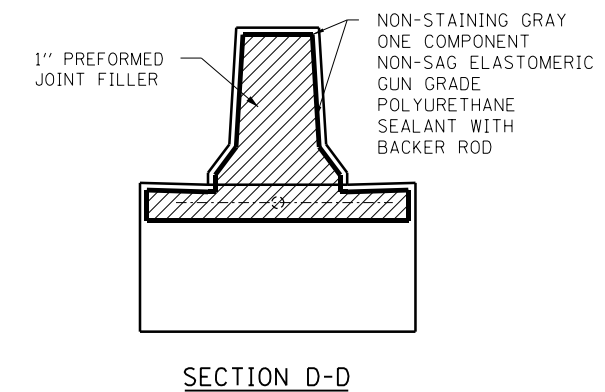
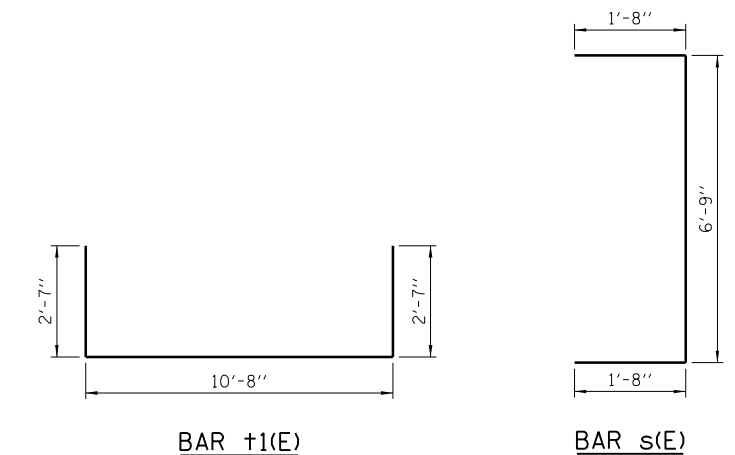

SECTION D-D

Paul Kovacs
APPROVED... CHIEF ENGINEER... DATE 2-7-2012

NOTE:
1. SEE NOTES ON SHEET 4 OF THIS SERIES.

SHEET 5 OF 5

OVERHEAD SIGN STRUCTURE
SPAN TYPE
STRUCTURE DETAILS
STANDARD F1-06

RESERVED

APPROVED CHIEF ENGINEER DATE

DATE	REVISIONS



RESERVED

STANDARD F2-00

RESERVED

APPROVED..... CHIEF ENGINEER DATE

DATE	REVISIONS



RESERVED

STANDARD F3-00

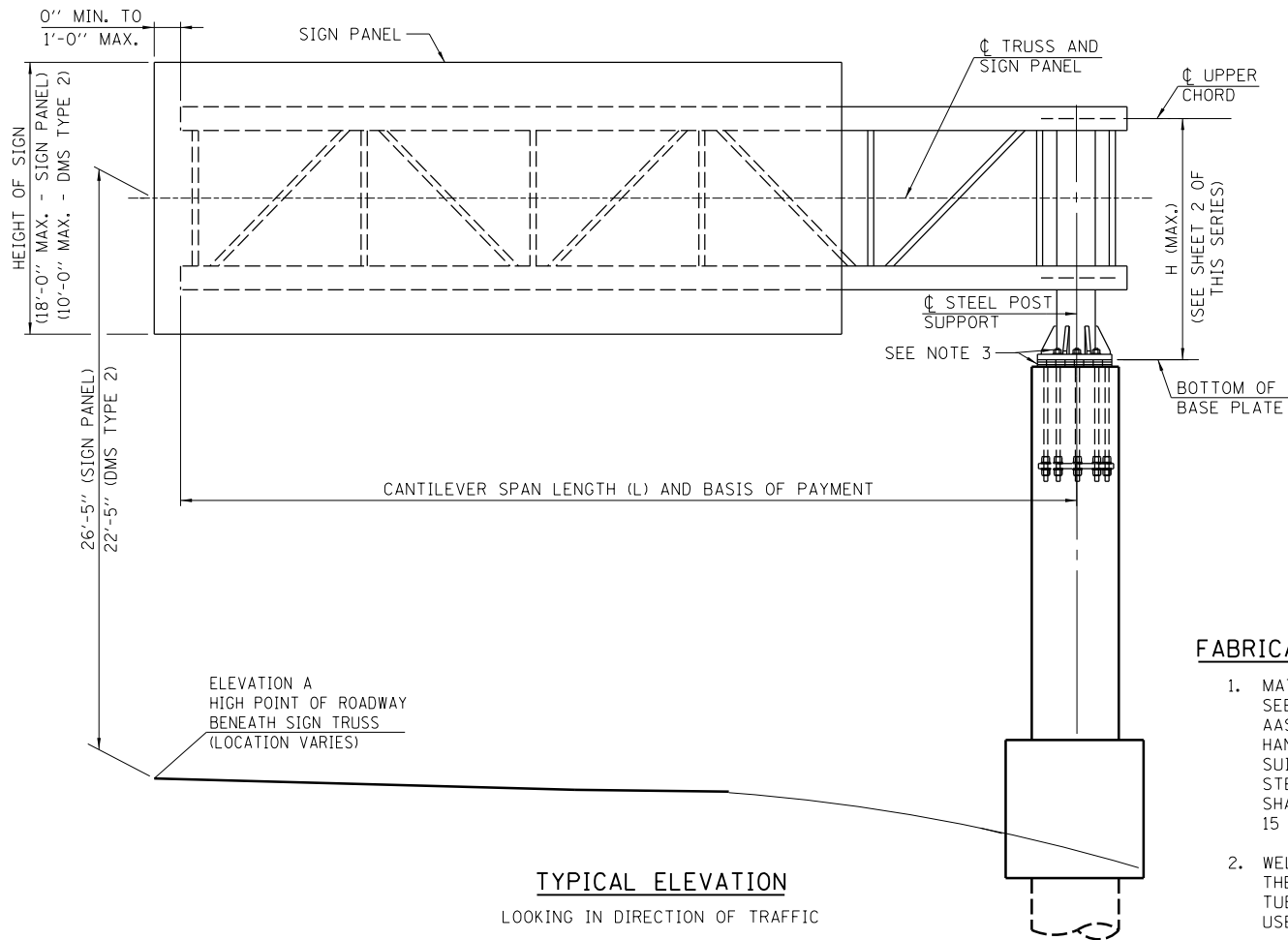
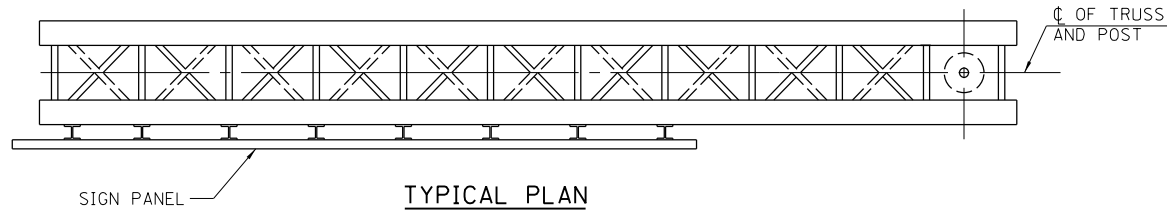
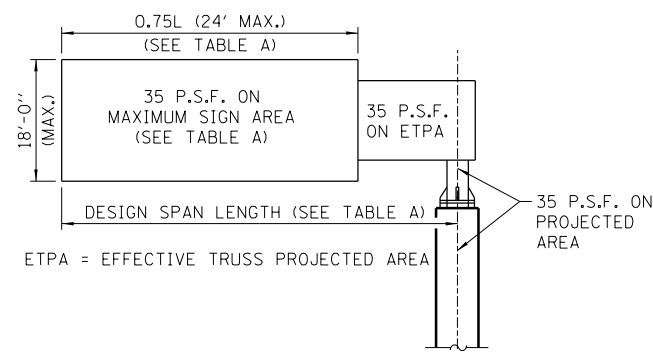

TABLE A: MAXIMUM LIMITS FOR SIGNS

TRUSS TYPE	DESIGN SPAN LENGTH (FT.)	MAXIMUM SIGN AREA (SQ. FT.)	MAXIMUM SIGN LENGTH (FT.)
20-D	20	270	15
25-D	25	338	18.75
30-D	30	405	22.5
35-D	35	432	24
40-D	40	432	24
45-D	45	432	24
50-D	50	432	24



DESIGN WIND LOADING DIAGRAM

FABRICATION NOTES:

- MATERIALS: FOR MATERIAL SPECIFICATIONS FOR CANTILEVER SIGN STRUCTURES, SEE TABLE B. ALL STRUCTURAL STEEL PLATES AND SHAPES SHALL CONFORM TO AASHTO M270 GR. 50. STAINLESS STEEL FOR SHIMS, SLEEVES AND HANDHOLE COVERS SHALL BE ASTM A240, TYPE 302 OR 304 OR ANOTHER ALLOY SUITABLE FOR EXTERIOR EXPOSURE AND ACCEPTABLE TO THE ENGINEER. THE STEEL PIPE AND STIFFENING RIBS AT THE BASE PLATE FOR THE STEEL POST SHALL HAVE A MINIMUM LONGITUDINAL CHARPY V-NOTCH (CVN) ENERGY OF 15 LB.-FT. AT 40° F (ZONE 2) BEFORE GALVANIZING.
- WELDING: ALL MATERIALS, WELDING PROCEDURES AND INSPECTION USED FOR THE CANTILEVER OVERHEAD SIGN STRUCTURE SHALL CONFORM TO AWS D1.1-10 FOR TUBULAR, CYCLICALLY LOADED STRUCTURES. ADDITIONALLY, ALL WELDED MATERIALS USED SHALL BE PREQUALIFIED FOR USE WITH WPS AS PER AWS D1.1-10, TABLE 3.1.
- FASTENERS FOR STEEL TRUSSES: HIGH STRENGTH BOLTS MUST SATISFY THE REQUIREMENTS OF AASHTO M164 (ASTM A325), OR APPROVED ALTERNATE, AND MUST HAVE MATCHING LOCKNUTS. THREADED STUDS FOR SPLICES (IF MEMBERS INTERFERE) MUST SATISFY THE REQUIREMENTS OF ASTM A449, ASTM A193 GRADE B7, OR APPROVED ALTERNATE, AND MUST HAVE MATCHING LOCKNUTS. BOLTS AND LOCKNUTS NOT REQUIRED TO BE HIGH STRENGTH MUST SATISFY THE REQUIREMENTS OF ASTM A307. ALL BOLTS AND LOCKNUTS MUST BE HOT DIP GALVANIZED PER AASHTO M232, EXCEPT STAINLESS STEEL FASTENERS, NUTS AND WASHERS. THE LOCKNUTS MUST HAVE NYLON OR STEEL INSERTS. A STAINLESS STEEL FLAT WASHER CONFORMING TO ASTM A240 TYPE 302 OR 304, IS REQUIRED UNDER BOTH HEAD AND NUT OR UNDER BOTH NUTS WHERE THREADED STUDS ARE USED. HIGH STRENGTH BOLT INSTALLATION SHALL CONFORM TO ARTICLE 505.04(F)(2)d OF THE IDOT STANDARD SPECIFICATIONS FOR ROAD AND BRIDGE CONSTRUCTION. ROTATIONAL CAPACITY ("ROCAP") TESTING OF BOLTS WILL NOT BE REQUIRED.
- U-BOLTS: U-BOLTS MUST BE PRODUCED FROM ASTM A276 TYPE 304, 304L, 316 OR 316L, CONDITION A, COLD FINISHED STAINLESS STEEL, OR AN EQUIVALENT MATERIAL ACCEPTABLE TO THE ENGINEER. ALL NUTS FOR U-BOLTS MUST BE LOCKNUTS EQUIVALENT TO ASTM A307 WITH NYLON OR STEEL INSERTS AND HOT DIP GALVANIZED PER AASHTO M232. A STAINLESS STEEL FLAT WASHER CONFORMING TO ASTM A240, TYPE 302 OR 304, IS REQUIRED UNDER EACH U-BOLT LOCKNUT.
- GALVANIZING: ALL PLATES, SHAPES AND PIPE SHALL BE HOT DIP GALVANIZED AFTER FABRICATION IN ACCORDANCE WITH AASHTO M111. PAINTING IS NOT PERMITTED. ALL FASTENERS SHALL BE HOT DIP GALVANIZED IN ACCORDANCE WITH AASHTO M111 OR M232 AS APPROPRIATE FOR THE PRODUCT (EXCEPT STAINLESS STEEL FASTENERS).

TABLE B: MATERIAL SPECIFICATIONS FOR STRUCTURAL STEEL AND FASTENERS

ELEMENT OF STRUCTURE	SPECIFICATION	MINIMUM YIELD STRENGTH (K.S.I.)	MINIMUM ULTIMATE STRENGTH (K.S.I.)
STRUCTURAL STEEL TUBE	ASTM A500 GRADE B	46	58
STRUCTURAL STEEL POST AND PIPE	API 5L GRADE B OR X42 OR X52	35	52
	ASTM A106 GRADE B	35	60
STEEL BAR AND STEEL PLATES	ASTM A53, TYPE E OR S, GRADE B	35	60
	ASTM A572 GRADE 50	50	65
STAINLESS STEEL BOLTS	ASTM A193, CLASS 1, GRADE B8	30	75
STRUCTURAL STEEL BOLTS	ASTM 325 TYPE 1	--	105
STAINLESS STEEL LOCKNUTS	ASTM A194 GRADE 8F	--	--
	ASTM A194 GRADE 2H	--	--
NUTS	ASTM A563 GRADE DH	--	--
STEEL WASHERS	ASTM F436	--	--
STAINLESS STEEL WASHERS	ASTM A240, TYPE 302	--	--
STEEL ANCHOR BOLTS	AASHTO M314 OR ASTM F1554	55	75

SHOP CAMBER TABLE

CANTILEVER LENGTH (L)	SHOP CAMBER AT END
20'	1 1/2"
25'	1 1/2"
30'	2"
35'	2 1/2"
40'	2 1/2"
45'	3"
50'	3 1/2"

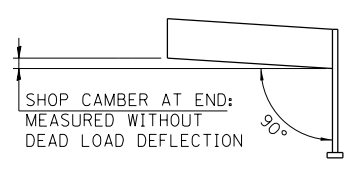

CAMBER DIAGRAM (FOR FABRICATION ONLY)

GENERAL NOTES:

- WORK THIS SHEET WITH OVERHEAD SIGN STRUCTURE CANTILEVER TYPE SUMMARY AND TOTAL BILL OF MATERIAL SHEET.
- AFTER ADJUSTMENTS TO LEVEL TRUSS AND ENSURE ADEQUATE VERTICAL CLEARANCE, ALL TOP AND LEVELING NUTS SHALL BE TIGHTENED AGAINST THE BASE PLATE WITH A MINIMUM TORQUE OF 200 LB.-FT. STAINLESS STEEL MESH SHALL THEN BE PLACED AROUND THE PERIMETER OF THE BASE PLATE. SECURE TO BASE PLATE WITH STAINLESS STEEL BANDING.
- SIGN SUPPORT STRUCTURES MAY BE SUBJECT TO DAMAGING VIBRATIONS AND OSCILLATIONS WHEN SIGN PANELS ARE NOT IN PLACE DURING ERECTION OR MAINTENANCE OF THE STRUCTURE. TO AVOID THESE, ATTACH TEMPORARY BLANK SIGN PANELS OR OTHER BRACING TO THE STRUCTURE UNTIL PERMANENT SIGNS ARE INSTALLED.
- TRUSSES SHALL BE SHIPPED INDIVIDUALLY WITH ADEQUATE PROVISION TO PREVENT DETRIMENTAL MOTION DURING TRANSPORT. THE CONTRACTOR IS RESPONSIBLE FOR MAINTAINING THE CONFIGURATION AND PROTECTION OF THE TRUSSES.
- ALL WELDS SHALL BE CONTINUOUS UNLESS OTHERWISE SHOWN. ALL WELDING SHALL BE DONE IN ACCORDANCE WITH CURRENT AWS D1.1 STRUCTURE WELDING CODE AND THE STANDARD SPECIFICATIONS.
- ALL STEEL PLATES, SHAPES AND PIPE SHALL BE HOT DIP GALVANIZED AFTER FABRICATION IN ACCORDANCE WITH AASHTO M111.
- PROVIDE RUBBED SURFACE FINISH FOLLOWED BY CONCRETE SEALER APPLICATION ON ENTIRE SURFACE OF CONCRETE COLUMN AND NORMAL SURFACE FINISH ON GRADE BEAM, EXCEPT BOTTOM SURFACE. COST IS INCLUDED IN THE COST OF "FOUNDATION FOR OVERHEAD SIGN STRUCTURE, CANTILEVER TYPE".
- REINFORCEMENT BARS DESIGNATED (E) SHALL BE EPOXY COATED IN ACCORDANCE WITH THE STANDARD SPECIFICATIONS.
- DMS TYPE 2 IS PERMITTED TO BE INSTALLED ON CANTILEVER TRUSS. DO NOT INSTALL SIGN PANEL IN CONJUNCTION WITH DMS TYPE 2. SEE SHEET 9 OF THIS SERIES FOR PERMISSIBLE SIGN SIZE AND WEIGHT.

CONSTRUCTION SPECIFICATIONS:

- ALL MATERIALS, EXCEPT AS SHOWN, FABRICATION, ERECTION AND CONSTRUCTION REQUIREMENTS SHALL BE IN ACCORDANCE WITH SECTION 733 OF THE LATEST ILLINOIS TOLLWAY SUPPLEMENTAL SPECIFICATIONS.
- THE COST OF FURNISHING AND INSTALLING THE STAINLESS STEEL BAND AND WIRE MESH CLOTH IS INCLUDED IN THE COST OF "OVERHEAD SIGN STRUCTURE, CANTILEVER TYPE (STEEL)".

LOADING:

- ALL CANTILEVER TRUSSES ARE DESIGNED FOR AN 18'-0" DEEP SIGN PANEL OVER 75% OF THE ARM LENGTH, WITH A MAXIMUM PANEL WIDTH OF 24'-0".
- ALL CANTILEVER TRUSSES ARE DESIGNED FOR 35 PSF WIND PRESSURE ON TRUSS MEMBERS AND SIGN PANEL.
- THE AASHTO GROUP II AND III ALLOWABLE STRESS SHALL BE 133% (ALLOWABLE STRESS DESIGN).

DESIGN SPECIFICATIONS:

THESE STRUCTURES ARE DESIGNED TO SATISFY THE 2013 AASHTO STANDARD SPECIFICATIONS FOR STRUCTURAL SUPPORTS FOR HIGHWAY SIGNS, LUMINAIRES AND TRAFFIC SIGNALS, SIXTH EDITION.

CONCRETE COLUMN, GRADE BEAM AND DRILLED SHAFT ARE DESIGNED IN ACCORDANCE WITH THE 2012 EDITION OF THE AASHTO LRFD BRIDGE DESIGN SPECIFICATIONS (INCLUDING THE 2013 INTERIM REVISIONS).

DESIGN UNIT STRESSES FOR REINFORCED CONCRETE:

CLASS SI CONCRETE	f'c = 3,500 P.S.I.
CLASS DS CONCRETE	f'c = 4,000 P.S.I.
REINFORCING STEEL	fy = 60,000 P.S.I.



OVERHEAD SIGN STRUCTURE CANTILEVER TYPE STRUCTURE DETAILS

STANDARD F4-07

DATE	REVISIONS
2-1-2013	REVISED SIGN PARAMETERS
12-12-2013	REVISED TABLES AND NOTES
2-07-2014	REVISED STEEL POST TO CONCRETE
3-31-2014	ADDED DMS TYPE II
7-01-2014	ADDED DIMENSIONS AND REVISED NOTES
3-11-2015	ADDED DIMENSIONS AND REVISED NOTES
3-31-2016	REVISED FOUNDATION NOTE

APPROVED: *Paul Kovacs* CHIEF ENGINEER DATE 3-31-2014

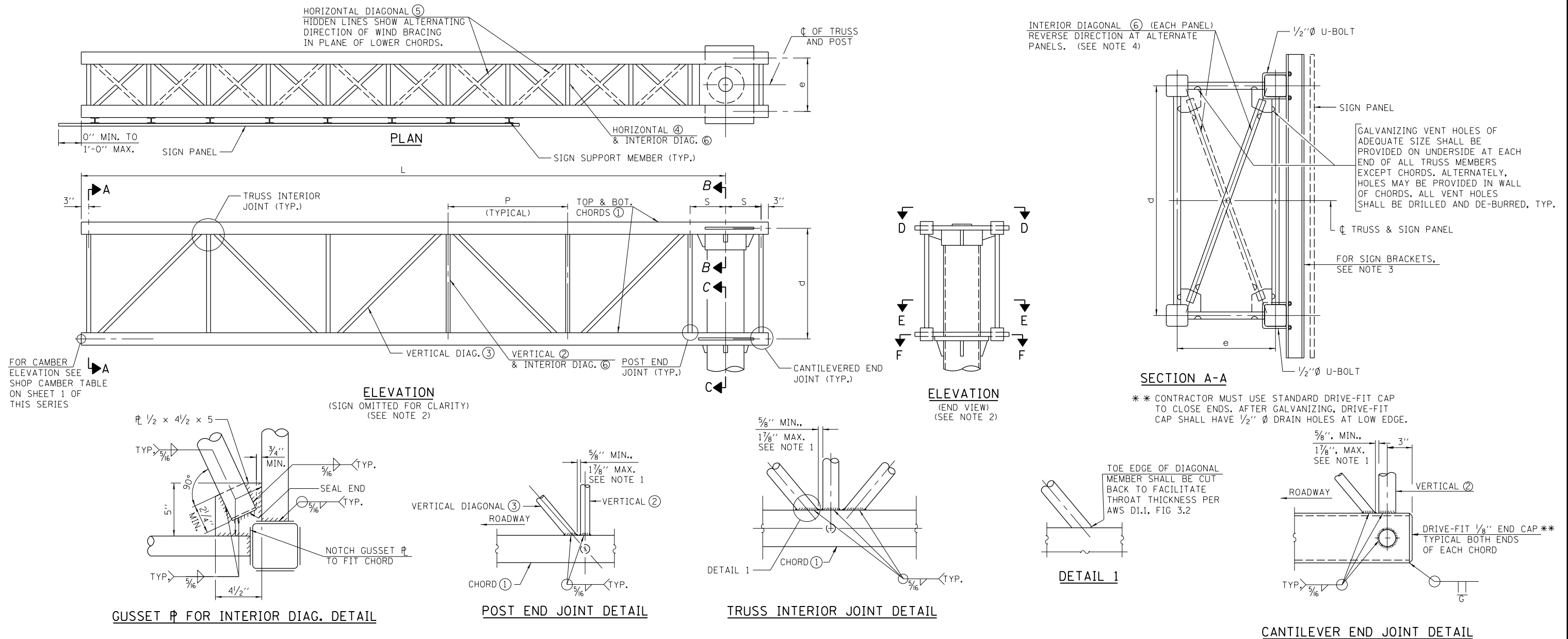

TABLE C: TRUSS AND POST DETAILS FOR 18'-0" (MAX.) SIGN HEIGHT

DESIGN SPAN LENGTH (L)	TRUSS TYPE	TRUSS SIZE		ACTUAL SPAN LENGTH	MAXIMUM SIGN LENGTH	STEEL SUPPORT POST (COLUMN)				TRUSS MEMBERS AND DETAILS													
		e	d			DIAMETER	WEIGHT	* WALL THICKNESS	H (MAX.)	TOP & BOTTOM CHORD (1)	VERTICAL (2)		VERTICAL DIAG. (3)		HORIZONTAL (4)		HORIZONTAL DIAG. (5)		INTERIOR DIAG. (6)		PANELS		
											PIPE	WALL	PIPE	WALL	PIPE	WALL	PIPE	WALL	PIPE	WALL	NO.	P	S
20'	20-D	2'-6"	5'-6"	20'-1"	15'-0"	18"	138.30 (#/FT)	0.75"	12'-0"	HSS 5x5x1/4	2 1/2" Ø X.S	0.276"	3" Ø X.X.S	0.600"	1 1/2" Ø X.S	0.200"	2 1/2" Ø X.S	0.276"	1 1/2" Ø X.S	0.200"	4	4'-7"	1'-6"
25'	25-D	3'-6"	5'-6"	24'-11"	18'-9"	18"	181.73 (#/FT)	1"	12'-0"	HSS 5x5x1/4	2 1/2" Ø X.S	0.276"	3" Ø X.X.S	0.600"	2" Ø X.S	0.218"	2 1/2" Ø X.S	0.276"	2" Ø X.S	0.218"	5	4'-7"	1'-9"
30'	30-D	3'-6"	7'-0"	30'-2"	22'-6"	18"	181.73 (#/FT)	1"	12'-0"	HSS 6x6x1/4	3" Ø X.S	0.300"	4" Ø X.X.S	0.674"	2" Ø X.S	0.218"	2 1/2" Ø X.S	0.276"	2" Ø X.S	0.218"	5	5'-7"	2'-0"
35'	35-D	4'-0"	7'-0"	35'-0"	24'-0"	24"	186.41 (#/FT)	0.75"	12'-0"	HSS 6x6x1/4	3" Ø X.S	0.300"	4" Ø X.X.S	0.674"	2" Ø X.S	0.218"	2 1/2" Ø X.S	0.276"	2" Ø X.S	0.218"	5	6'-6"	2'-3"
40'	40-D	4'-0"	7'-0"	40'-0"	24'-0"	24"	186.41 (#/FT)	0.75"	12'-0"	HSS 6x6x1/4	3" Ø X.S	0.300"	4" Ø X.X.S	0.674"	2" Ø X.S	0.218"	2 1/2" Ø X.S	0.276"	2" Ø X.S	0.218"	6	6'-3"	2'-3"
45'	45-D	4'-6"	7'-0"	45'-0 1/2"	24'-0"	24"	245.87 (#/FT)	1"	12'-0"	HSS 6x6x1/4	3" Ø X.S	0.300"	4" Ø X.X.S	0.674"	2" Ø X.S	0.218"	2 1/2" Ø X.S	0.276"	2" Ø X.S	0.218"	7	6'-0 1/2"	2'-6"
50'	50-D	4'-6"	7'-0"	50'-1"	24'-0"	24"	245.87 (#/FT)	1"	12'-0"	HSS 6x6x1/4	3" Ø X.S	0.300"	4" Ø X.X.S	0.674"	2" Ø X.S	0.218"	2 1/2" Ø X.S	0.276"	2" Ø X.S	0.218"	8	5'-11"	2'-6"

* NOMINAL WALL THICKNESS SHOWN. THICKER WALL IS PERMITTED UPON ENGINEER'S APPROVAL.

NOTES:

1. TRUSS MEMBERS SHALL BE SPACED A MINIMUM OF 3 TIMES THE WALL THICKNESS OF THE LARGEST CONNECTING MEMBERS TO ENSURE PROPER WELD SPACING.
2. FOR SECTIONS B-B, C-C, D-D, E-E AND F-F SEE SHEET 3 OF THIS SERIES.
3. FOR SIGN SUPPORT DETAILS, SEE ILLINOIS TOLLWAY STANDARD DRAWING F8, FOR DMS TYPE 2 SIGN SUPPORT DETAILS, SEE SHEET 9 OF THIS SERIES.
4. DIRECTION OF INTERIOR DIAGONALS SHOWN IN SECTION A-A CORRECTLY DEPICTS TRUSSES HAVING AN ODD NUMBER OF PANELS. TRUSSES WITH AN EVEN NUMBER OF PANELS WILL HAVE DIAGONALS IN A REVERSED DIRECTION THAN AS SHOWN.
5. FOR ANY DESIGN SPAN LENGTH THAT FALLS BETWEEN TWO CONSECUTIVE SPANS, PROVIDED IN COLUMN 1 OF TABLE C, THE LARGER DESIGN SPAN LENGTH SHALL BE USED (I.E. FOR A 32' SPAN LENGTH FALLING BETWEEN 30' AND 35' DESIGN SPAN LENGTHS IN TABLE C, THE 35' DESIGN SPAN LENGTH TRUSS AND POST DETAILS SHALL BE USED).

Paul Kovacs
 APPROVED... CHIEF ENGINEER... DATE 3-31-2014.



OVERHEAD SIGN STRUCTURE
 CANTILEVER TYPE
 STRUCTURE DETAILS

STANDARD F4-07

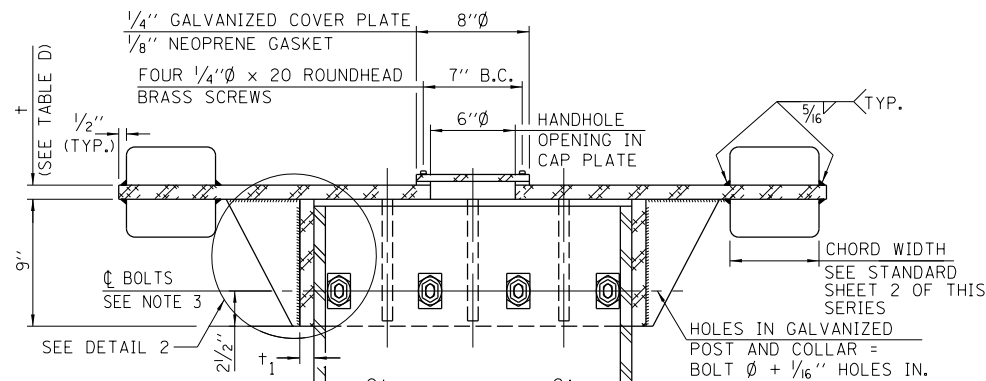

SECTION B-B

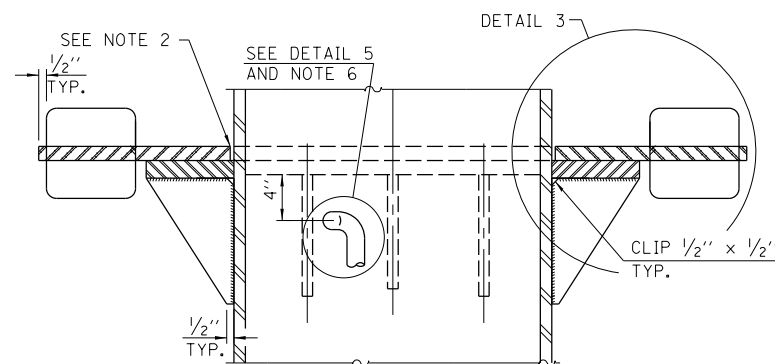

SECTION C-C

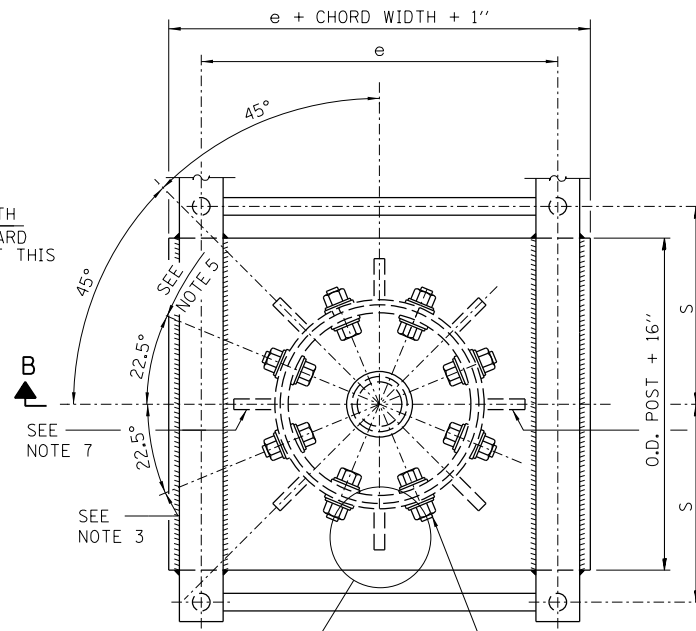

VIEW D-D
(CAP PLATE)

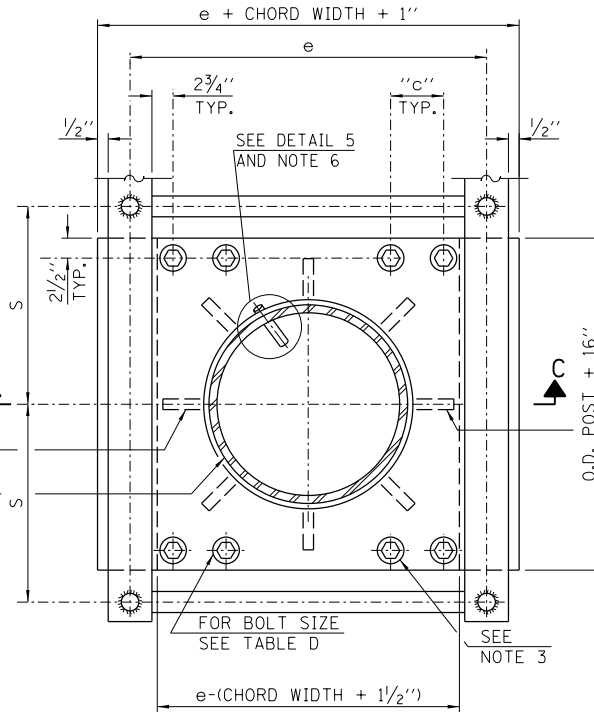

SECTION E-E
(JUNCTURE PLATE)

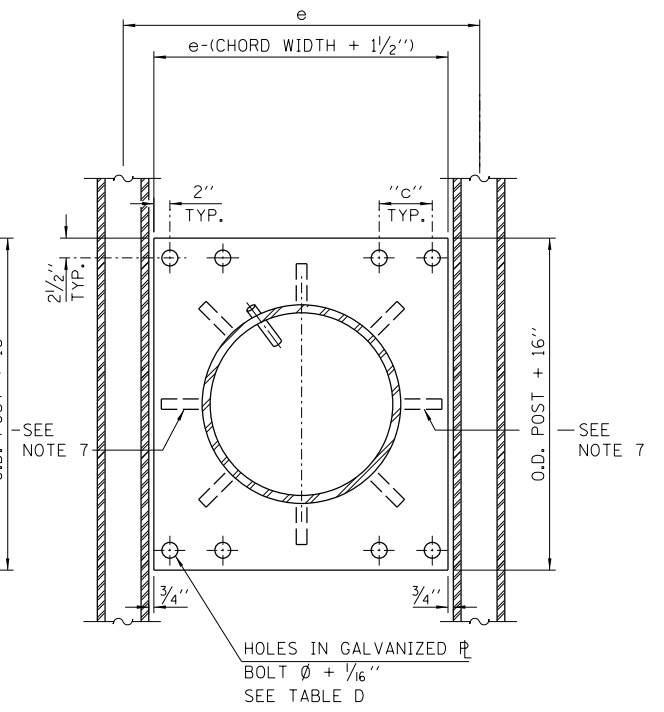

SECTION F-F
(SETTING PLATE)

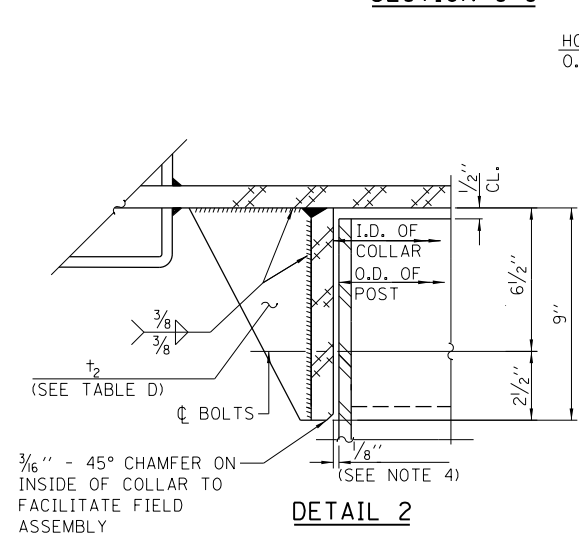

DETAIL 2

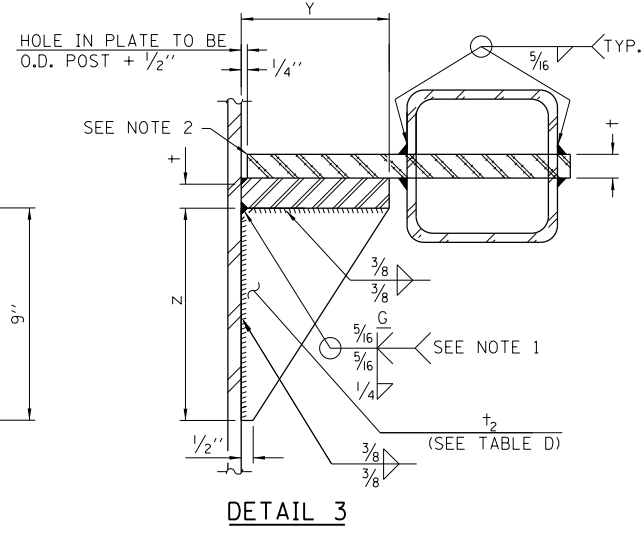

DETAIL 3

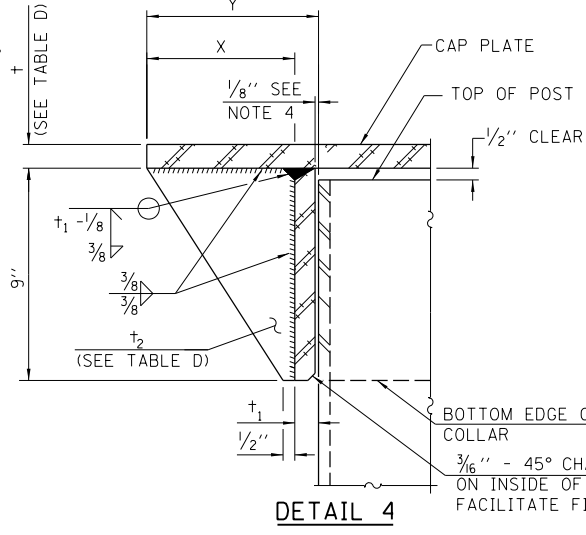

DETAIL 4

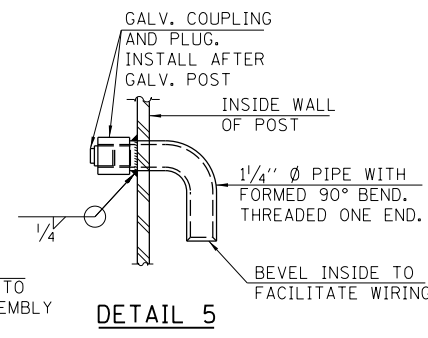

DETAIL 5

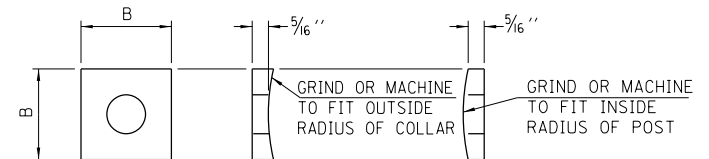

BOLT SIZE	CONTOURED WASHERS	
	HOLE DIA.	B
1 1/8" Ø	1 1/4" Ø	2 1/4"
1 1/4" Ø	1 3/8" Ø	2 1/4"
1 1/2" Ø	1 5/8" Ø	2 1/4"

CONTOURED WASHERS
(ASTM A240, TYPE 304)

NOTES:

- GRIND TOP IF REQUIRED TO FULLY SEAT PLATE. REPAIR DAMAGED GALVANIZING BEFORE ASSEMBLY.
- AFTER TIGHTENING LOWER CONNECTION BOLTS, FILL GAP WITH NON-HARDENING SILICONE CAULK SUITABLE FOR EXTERIOR EXPOSURE AND ACCEPTABLE TO THE ENGINEER. COST IS INCLUDED IN "OVERHEAD SIGN STRUCTURE, CANTILEVER TYPE (STEEL)".
- CONNECTION BOLTS IN COLLAR AND BOLTS AT LOWER CHORD CONNECTION MUST BE HIGH STRENGTH WITH MATCHING LOCKNUTS. LOWER CONNECTION BOLTS MUST HAVE 2 FLAT WASHERS EACH.
- AFTER GALVANIZING, COLLAR I.D. SHALL EQUAL O.D. OF GALVANIZED POST PLUS 1/8" (±1/16") MAXIMUM GAP BETWEEN POST AND COLLAR AT ANY LOCATION SHALL BE 1/8" BEFORE TIGHTENING BOLTS.
- OPTIONAL FULL PENETRATION WELD IN COLLAR. (TWO LOCATIONS MAXIMUM (180° APART) X-RAY OR UT 100%) ALL BOLTS SHOWN ARE HIGH STRENGTH.
- ORIENT PIPE TOWARD SIGN PANEL SIDE. HOLE IN POST = O.D. PIPE + 1/8".
- OMIT INDICATED STIFFENER IN TRUSS TYPE 20-D.

TABLE D: BOLT SCHEDULE

SPAN LENGTH	POST OUTSIDE DIAMETER	JUNCTURE & COLLAR CONNECTION BOLT DIAMETER	LOWER JUNCTURE BOLT SPACING DIMENSION "c"	PLATE THICKNESS		STIFFENER THICKNESS (t ₂)	NO. OF STIFFENERS	STIFFENERS		
				(t)	(t ₁)			x	y	z
< = 20'	18"	1 1/8"	3 3/8"	1"	3/4"	1/2"	6	5"	6"	8"
21'-30'	18"	1 1/2"	3 3/4"	1 1/8"	7/8"	3/4"	8	5"	6"	8"
31'-40'	24"	1 1/2"	4 1/2"	1 1/4"	1"	3/4"	8	7"	8"	10 1/2"
41'-50'	24"	1 1/2"	4 1/2"	1 1/4"	1"	3/4"	8	7"	8"	10 1/2"

Paul Kovacs
APPROVED... CHIEF ENGINEER... DATE 3-31-2014

B.C. = BOLT CIRCLE



OVERHEAD SIGN STRUCTURE
CANTILEVER TYPE
STRUCTURE DETAILS

STANDARD F4-07

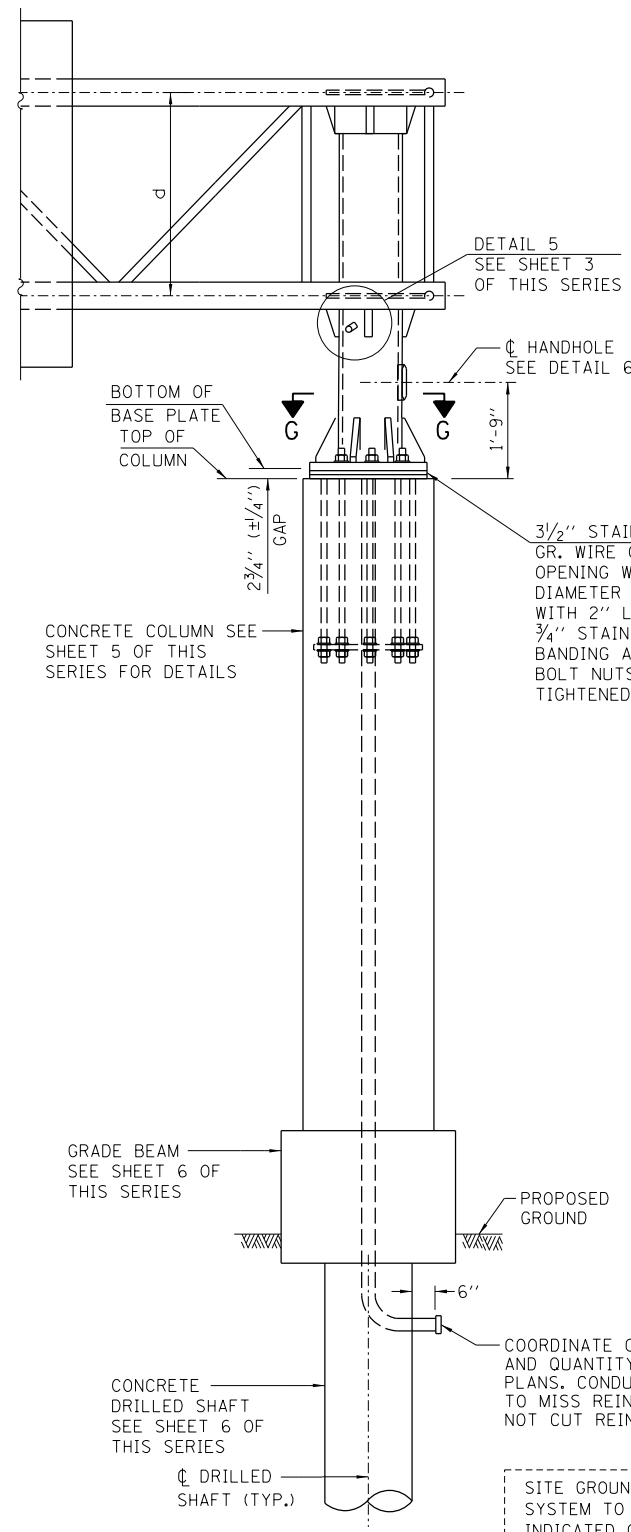

FRONT ELEVATION

ALL METALLIC MEMBERS ATTACHED TO THE CANTILEVER STEEL POST STRUCTURE SHALL BE BONDED TOGETHER BY MEANS OF A COPPER BONDING JUMPER TO CREATE A CONTINUOUS LOW IMPEDANCE PATH TO THE SITE GROUNDING ELECTRODE SYSTEM.

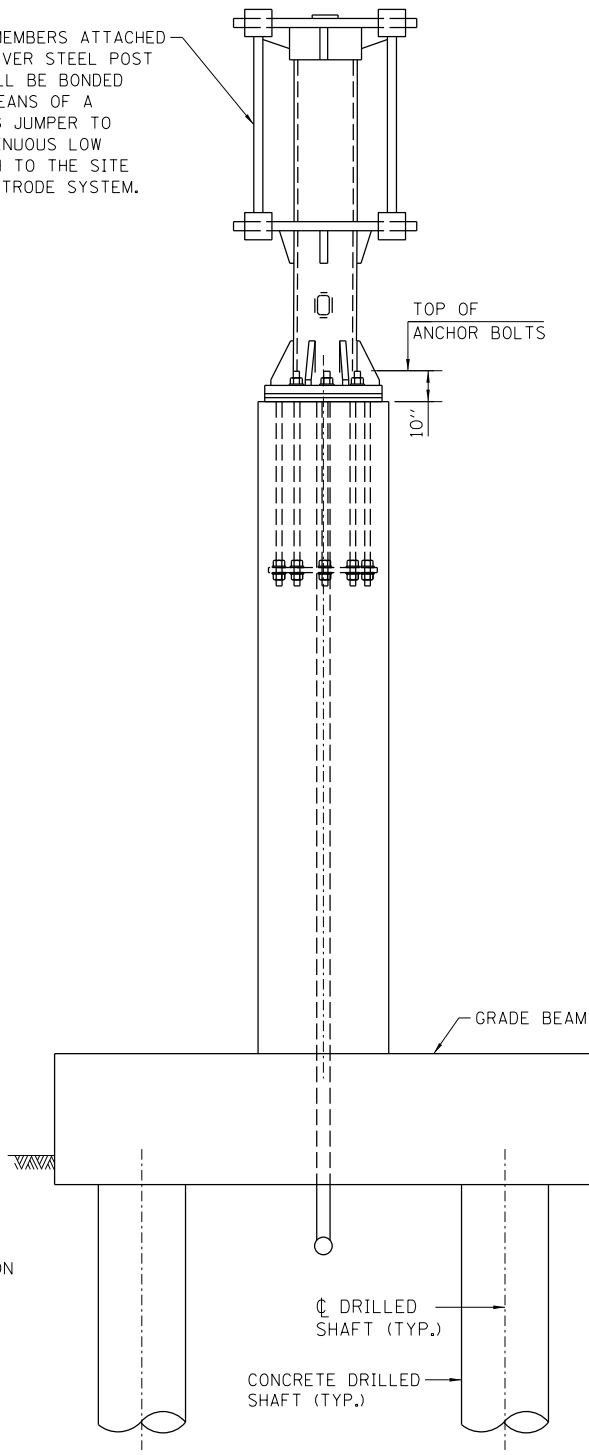

SIDE ELEVATION

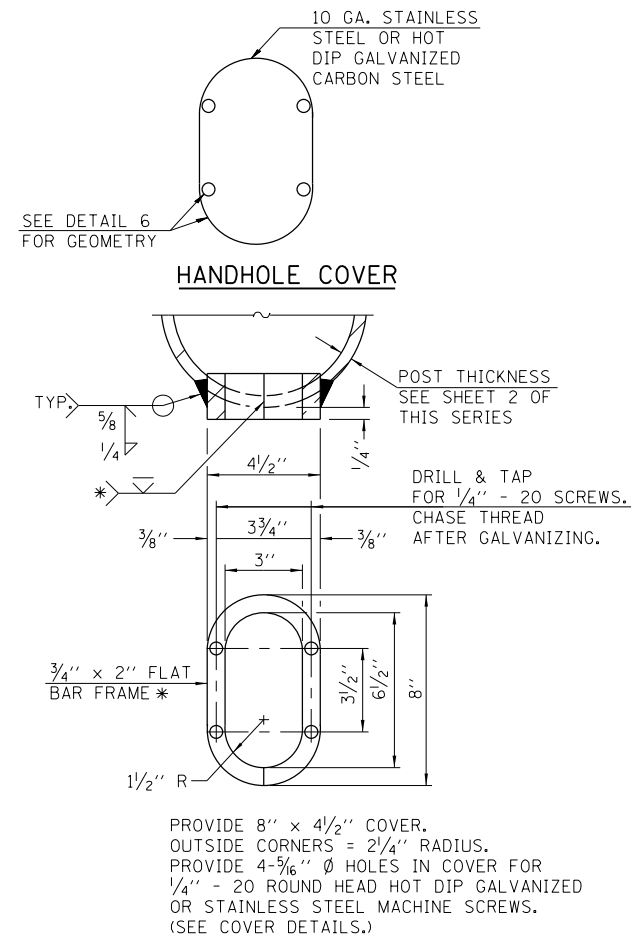

DETAIL 6

* BENT BARS MAY BE BUTT WELDED TOP AND BOTTOM OR BOTTOM ONLY. IN LIEU OF FABRICATED HANDHOLE FRAME AS SHOWN, MAY CUT FROM 2" PLATE (ROLLING DIRECTION VERTICAL). ALL CUT FACES TO BE GROUND TO ANSI ROUGHNESS OF 500 μIN OR LESS.

* * 18" IS MINIMUM TO BE GALVANIZED. ENTIRE BOLT MAY BE GALVANIZED AT CONTRACTOR'S OPTION.

TABLE E: BASE PLATE DETAIL

SPAN LENGTH (L)	POST OUTSIDE DIAMETER	BASE PLATE		BOLT CIRCLE	BOLT DIA.
		DIAMETER	THICKNESS		
<= 20'	18"	30"	2"	24"	1 3/4"
21'-30'	18"	30"	2"	24"	1 3/4"
31'-40'	24"	36"	2 1/2"	30"	2"
41'-50'	24"	36"	2 1/2"	30"	2 1/4"

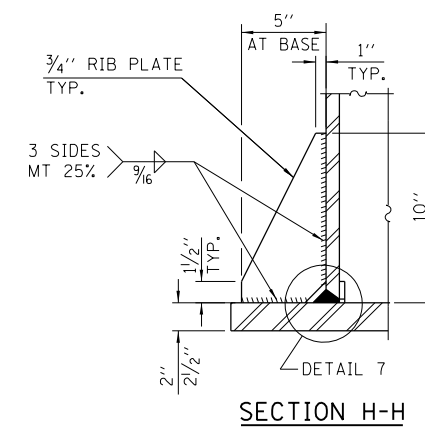

SECTION H-H

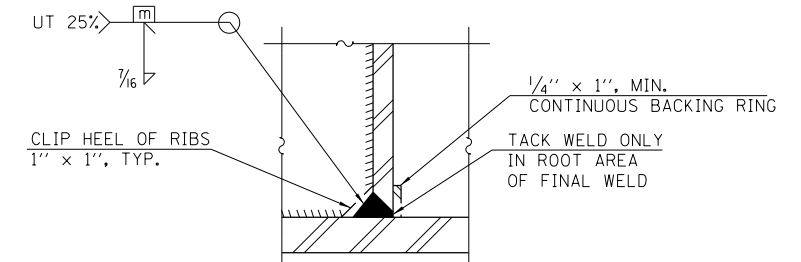

DETAIL 7 (TYPICAL RIB)

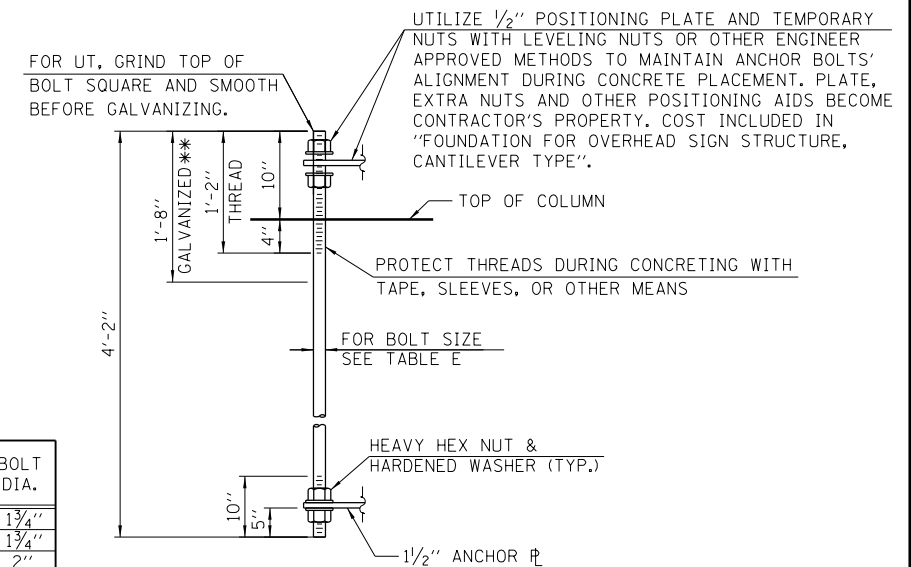

ANCHOR BOLT DETAIL

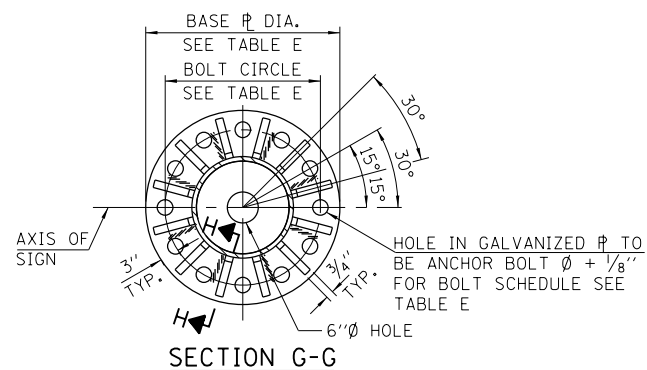

SECTION G-G

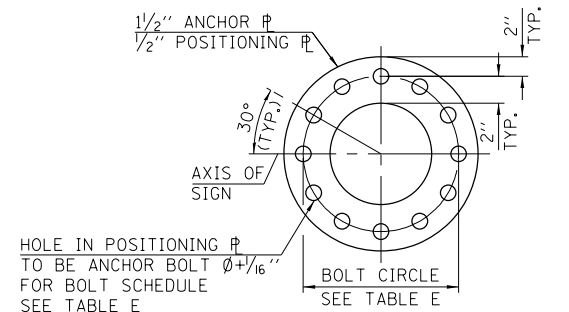

POSITIONING PL / ANCHOR PL

NOTE:

ANCHOR BOLTS SHALL CONFORM TO AASHTO M314 OR ASTM F1554 AND MEET CHARPY V-NOTCH (CVN) ENERGY OF 15 LB.-FT. AT 10° F. BEFORE GALVANIZING. GALVANIZE THE UPPER 18" (MINIMUM ***) AND ASSOCIATED M291, GRADE A, C OR DH HEAVY HEX NUTS AND HARDENED WASHERS PER AASHTO M293. NO WELDING SHALL BE PERMITTED ON BOLTS. PROVIDE AN UNFINISHED NUT AT BOTTOM, A HEXAGON LOCKNUT AND WASHER ABOVE BASE PLATE AND A LEVELING NUT AND WASHER BELOW BASE PLATE. NUTS SHALL EACH BE TIGHTENED WITH 200 LB.-FT. MINIMUM TORQUE AGAINST BASE PLATE. BEFORE OR AFTER THREADING, BUT BEFORE GALVANIZING, EACH ANCHOR BOLT SHALL BE ULTRASONICALLY TESTED (UT) BY A LEVEL II OR III INSPECTOR, QUALIFIED IN ACCORDANCE WITH ANSI GUIDELINES, USING A STRAIGHT BEAM, 1/2" Ø 3.5 MHZ. TRANSDUCER, TO ENSURE NO REJECTABLE FLAWS EXIST IN THE UPPER 18" (TENSION CRITERIA). COST OF TESTING INCLUDED IN THE COST OF "FOUNDATION FOR OVERHEAD STRUCTURE, CANTILEVER TYPE".

Paul Kovacs
APPROVED... CHIEF ENGINEER... DATE 3-31-2014



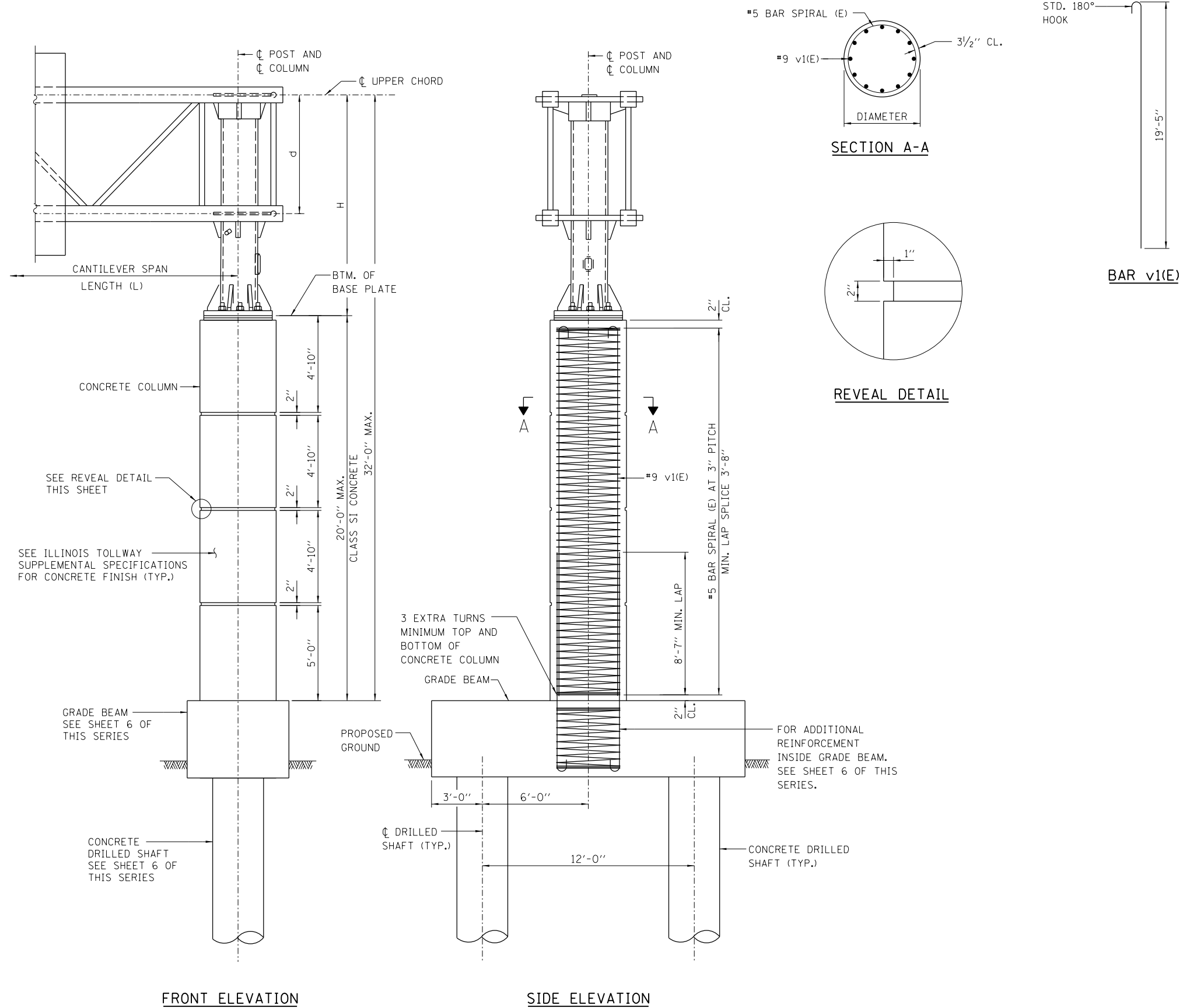

TABLE F: CONCRETE COLUMN DESIGN TABLE

SPAN LENGTH (L)	STEEL POST DIAMETER	CONCRETE COLUMN			
		DIAMETER	VERTICAL BAR	CLASS SI CONC. CU. YD.*	REINF. BARS POUND *
< = 20'	18"	3'-6"	16-#9	7.1	1,910
21'-30'	18"	3'-6"	16-#9	7.1	1,910
31'-40'	24"	4'-0"	20-#9	9.2	2,330
41'-50'	24"	4'-0"	20-#9	9.2	2,330

* CONCRETE VOLUME AND REBAR WEIGHT ARE DETERMINED FOR 20'-0" CONCRETE COLUMN HEIGHT. ADJUST CONCRETE VOLUME AND REBAR WEIGHT ACCORDINGLY IF CONCRETE COLUMN HEIGHT IS LESS THAN 20'-0".



BAR LIST - EACH FOUNDATION

(2 SHAFT AND 1 GRADE BEAM)

BAR	NUMBER	SIZE	LENGTH		SHAPE
			D = 3'-0"	D = 4'-0"	
h(E)	14	#8	17'-8"	17'-8"	—
p(E)	18	#8	17'-8"	17'-8"	—
s(E)	16	#5	17'-5"	19'-5"	□
s1(E)	24	#5	7'-8 1/2"	8'-2 1/2"	└
t(E)	12	#5	5'-7"	6'-7"	┌
u(E)	18	#4	8'-7"	9'-7"	┌
v(E)	SEE TABLE G	#9	44'-6"	44'-6"	┌
v2(E)	SEE TABLE G	#9	13'-9"	13'-9"	┌

#4 BAR SPIRAL (E) - SEE SIDE ELEVATION
#5 BAR SPIRAL (E) - SEE SIDE ELEVATION

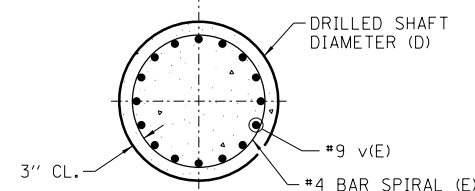
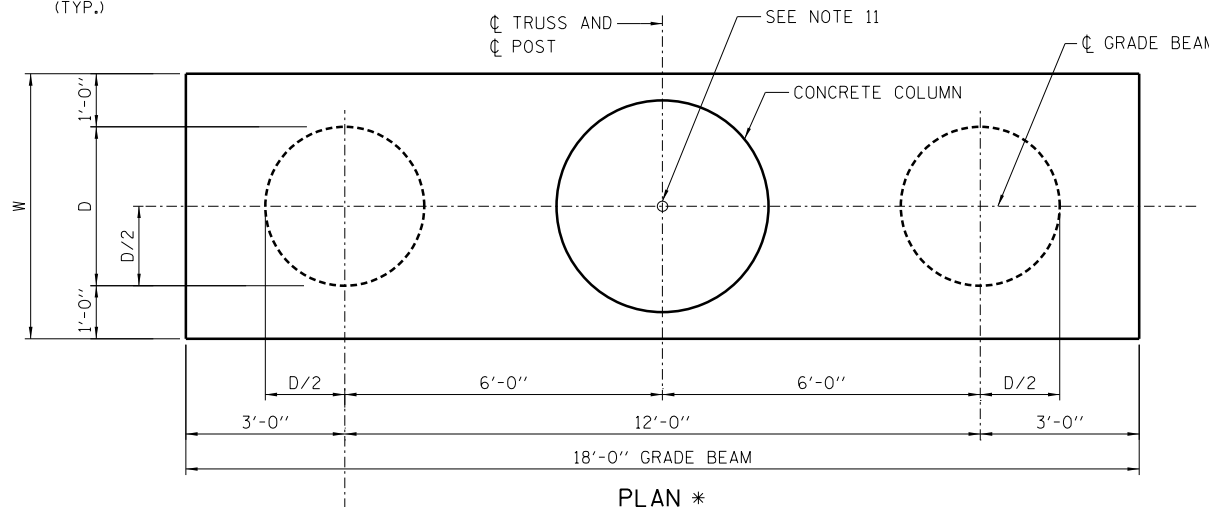
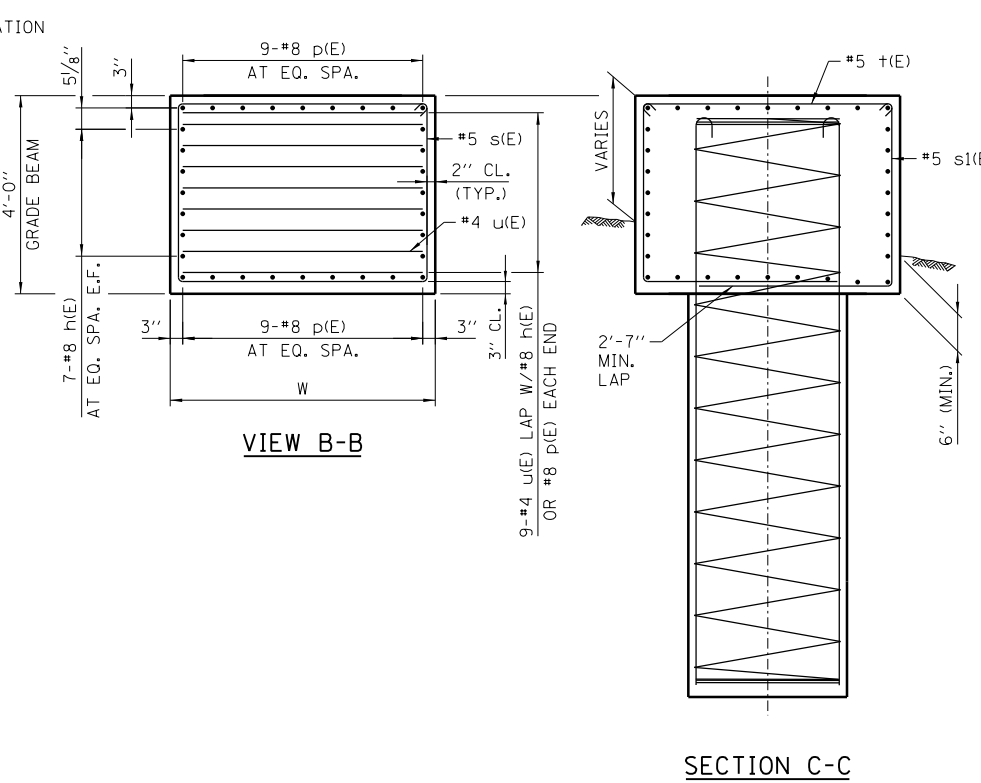
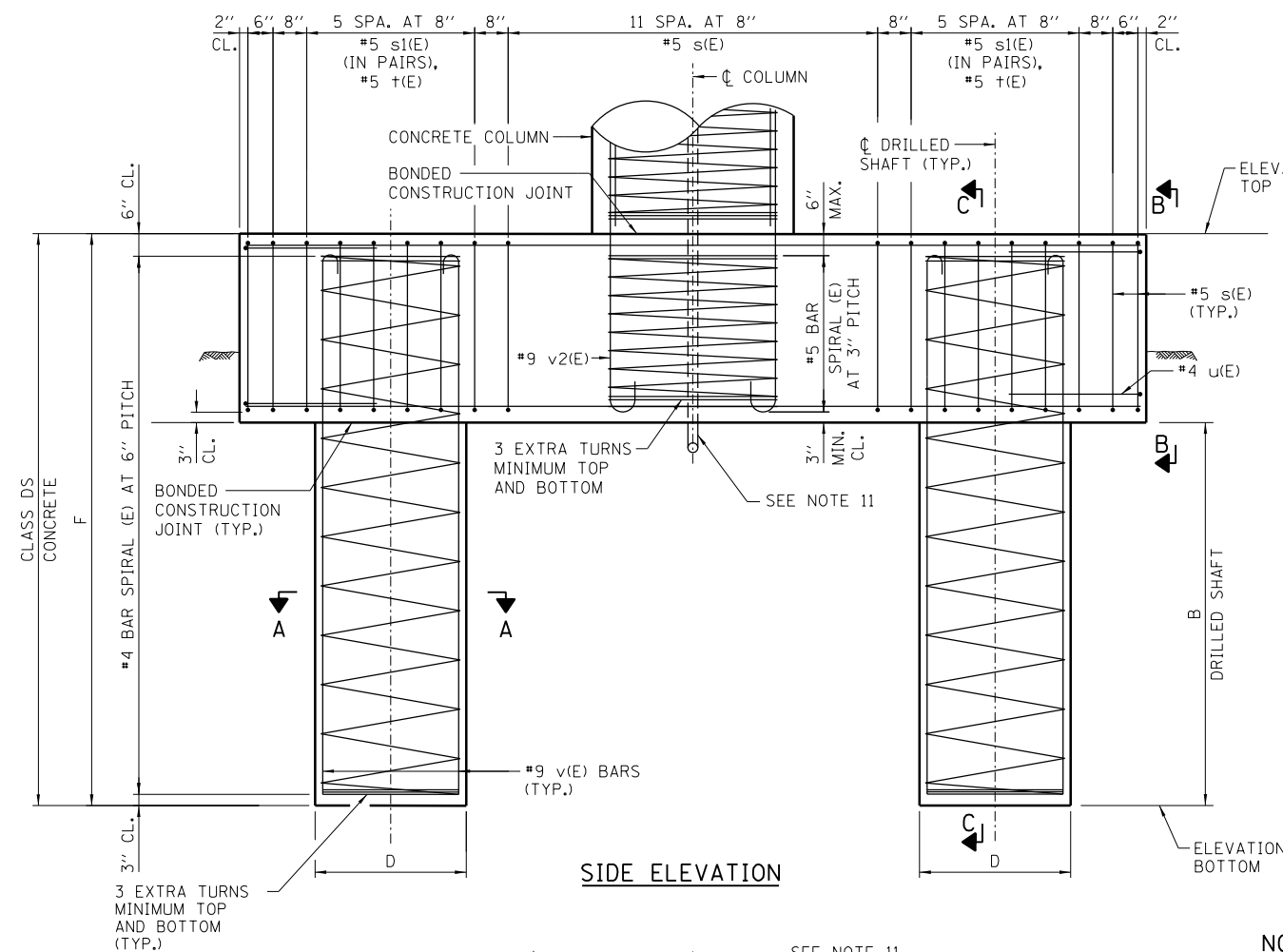

NOTES:

1. THE FOUNDATION DETAILS SHOWN ARE BASED ON THE PRESENCE OF MOSTLY COHESIVE SOIL CONDITIONS (SILTY OR SANDY CLAY), WITH AN AVERAGE UNCONFINED COMPRESSIVE STRENGTH (QU) > 1.25 TON/SQ. FT. WHICH MUST BE DETERMINED BY PREVIOUS SOIL INVESTIGATIONS AT THE JOBSITE. WHEN OTHER CONDITIONS ARE INDICATED, THE BORING DATA SHALL BE INCLUDED IN THE PLANS AND THE FOUNDATION DIMENSIONS SHOWN SHALL BE THE RESULT OF SITE SPECIFIC DESIGNS. IF CONDITIONS ENCOUNTERED IN THE FIELD ARE DIFFERENT THAN THOSE INDICATED, THE CONTRACTOR SHALL NOTIFY THE ENGINEER TO DETERMINE IF THE FOUNDATION DIMENSIONS NEED TO BE MODIFIED.
2. ALL MATERIAL, FABRICATION, AND CONSTRUCTION REQUIREMENTS SHALL BE IN ACCORDANCE WITH SECTION 734 OF THE ILLINOIS TOLLWAY SUPPLEMENTAL SPECIFICATIONS.
3. CONCRETE SHALL BE PLACED MONOLITHICALLY, WITHOUT CONSTRUCTION JOINTS UNLESS NOTED OTHERWISE.
4. BACKFILL SHALL BE PLACED PER SECTION 502 OF THE STANDARD SPECIFICATION AND PRIOR TO ERECTION OF CONCRETE COLUMN.
5. SEE NOTE 7 OF GENERAL NOTES ON SHEET 1 OF THIS SERIES.
6. ALL REBAR DESIGNATED (E) SHALL BE EPOXY COATED. REBAR SHALL BE POSITIONED SO THAT THERE WILL BE NO INTERFERENCE BETWEEN VERTICAL REINFORCEMENT AND STIRRUPS.
7. FURNISHING AND INSTALLING ALL CONDUIT, FITTINGS AND GROUNDING SYSTEM IS INCLUDED IN THE COST OF "FOUNDATION FOR OVERHEAD SIGN STRUCTURE, CANTILEVER TYPE".
8. NO SONOTUBES OR DECOMPOSABLE FORMS SHALL BE USED 6" BELOW THE FINISHED GROUND LINE. PERMANENT METAL FORMS OR OTHER SHIELDING MAY NOT BE LEFT IN PLACE BELOW THE ELEVATION WITHOUT THE ENGINEER'S WRITTEN PERMISSION. EXCAVATIONS SHALL BE DEWATERED BEFORE CONCRETE PLACEMENT IF DIRECTED BY THE ENGINEER AT NO ADDITIONAL COST.
9. FOR SIZE AND NUMBER OF PVC COATED STEEL CONDUITS, SEE ELECTRICAL CONSTRUCTION DRAWINGS.
10. TYPICAL SIGN STRUCTURE FOUNDATION IS SHOWN ON THIS SHEET. SEE SHEET 7 OF THIS SERIES FOR FOUNDATION LOCATED IN ROADWAY MEDIAN.
11. COORDINATE CONDUIT SIZE, LOCATION AND QUANTITY WITH ELECTRICAL PLANS. CONDUITS SHALL BE PLACED TO MISS REINFORCEMENT BARS. DO NOT CUT REINFORCEMENT BARS.

NOTE:
* REINFORCEMENT IN GRADE BEAM NOT SHOWN FOR CLARITY.
** FOR GRADE BEAM ONLY.

BAR SPIRAL LAP SPLICE	
BAR	MIN. LAP
#4	2'-11"
#5	3'-8"

TABLE G: DESIGN TABLE FOR DRILLED SHAFTS IN COHESIVE SOILS

SPAN LENGTH (L)	W	D	B	F	VERTICAL BAR		CLASS DS CONC. CU. YD.**	CLASS DS CONC. CU. YD.	REINF. BARS POUND
					v(E)	v2(E)			
< = 20'	5'-0"	3'-0"	40'	44'	12-#9	16-#9	13.4	21	7,680
21'-30'	5'-0"	3'-0"	40'	44'	12-#9	16-#9	13.4	21	7,680
31'-40'	6'-0"	4'-0"	40'	44'	20-#9	20-#9	16	37.3	9,570
41'-50'	6'-0"	4'-0"	40'	44'	20-#9	20-#9	16	37.3	9,570

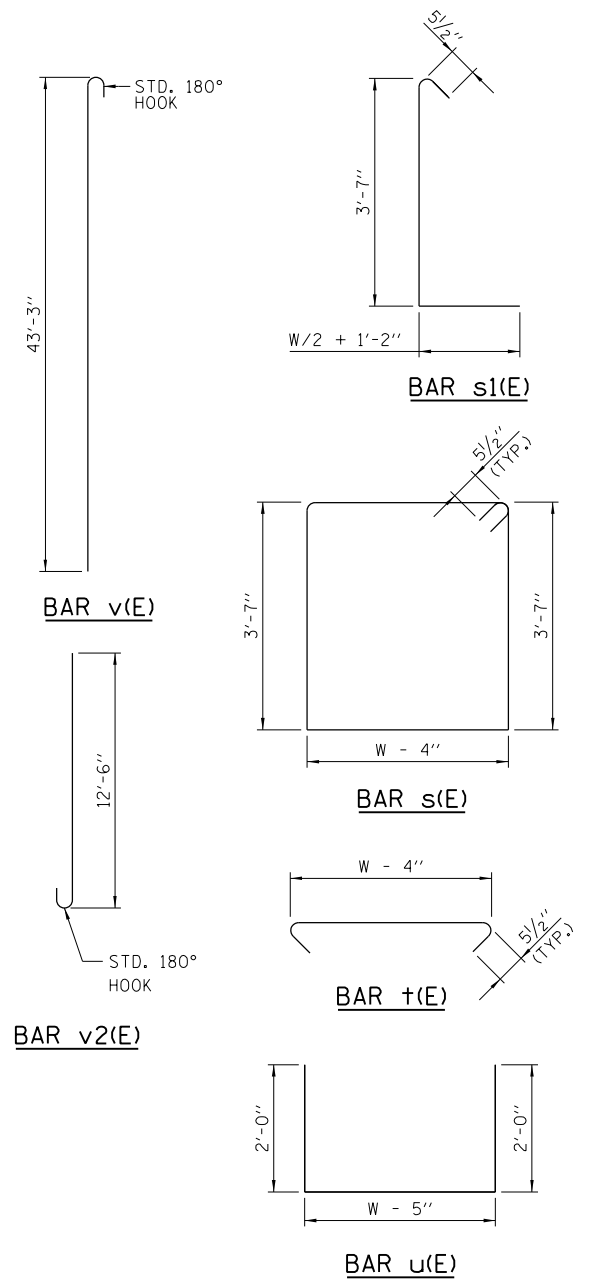

OVERHEAD SIGN STRUCTURE
CANTILEVER TYPE
STRUCTURE DETAILS

STANDARD F4-07

Paul Kovacs
APPROVED... CHIEF ENGINEER... DATE 3-31-2014

BAR LIST - CRASHWALL

BAR	SIZE	G = 4'-6"		G = 5'-0"		SHAPE
		NUMBER	LENGTH	NUMBER	LENGTH	
u1(E)	#5	14	11'-2"	14	12'-2"	
v3(E)	#5	24	4'-10"	28	4'-10"	
v4(E)	#5	24	2'-0"	28	2'-0"	

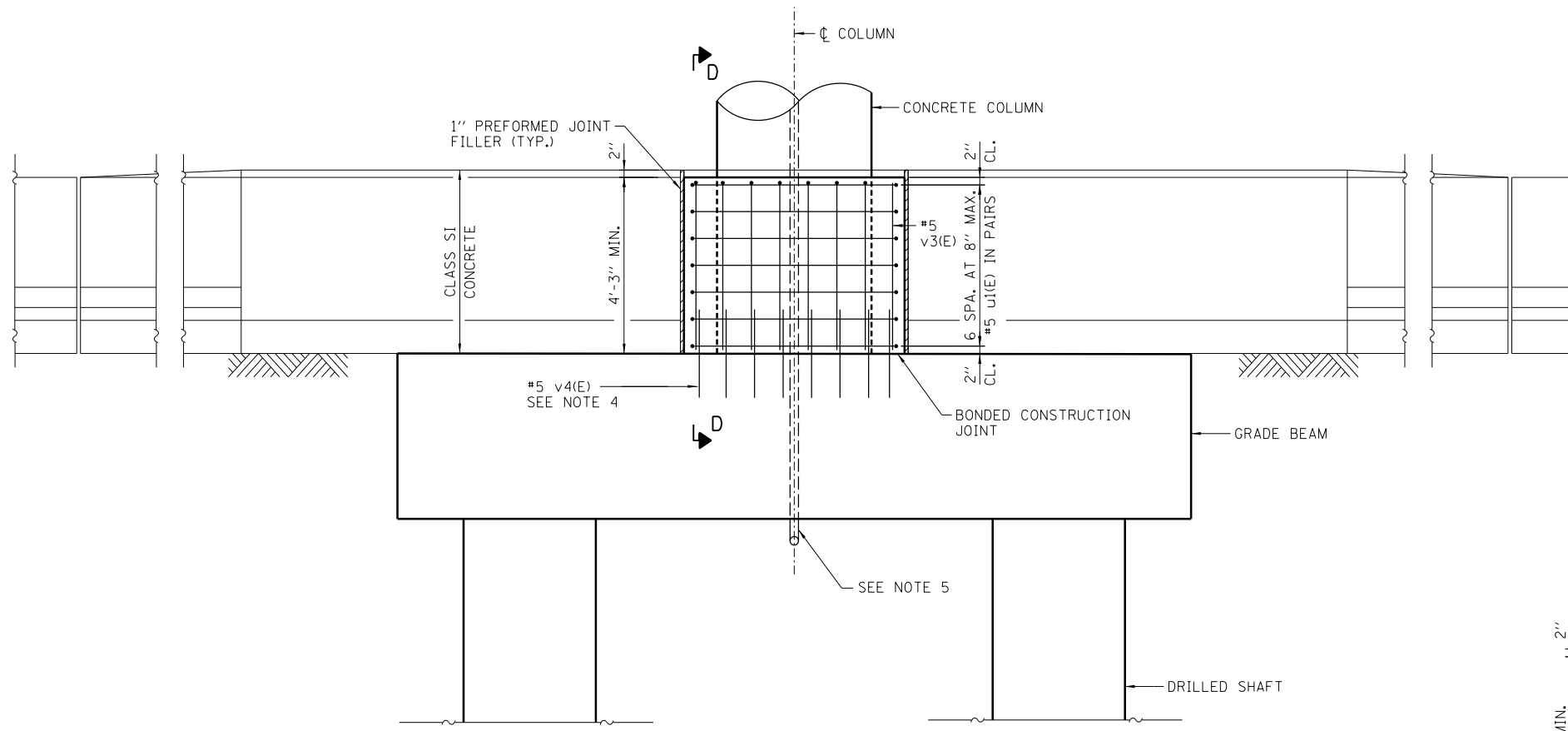

SIDE ELEVATION

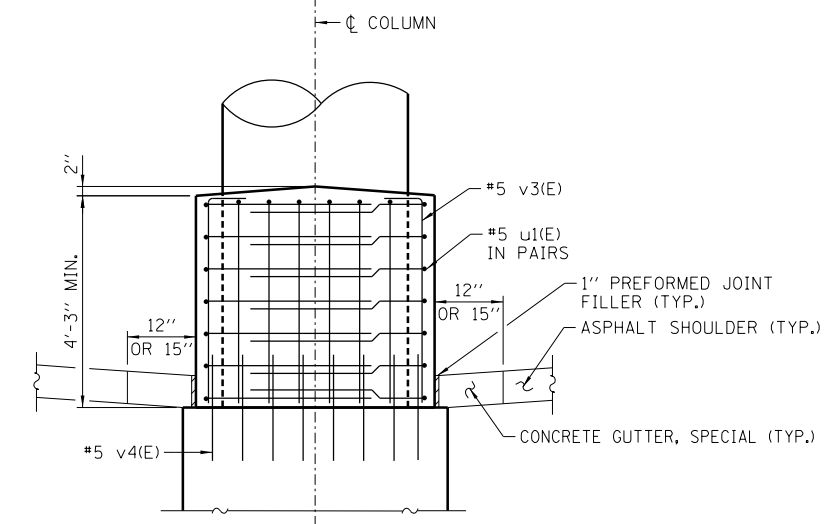
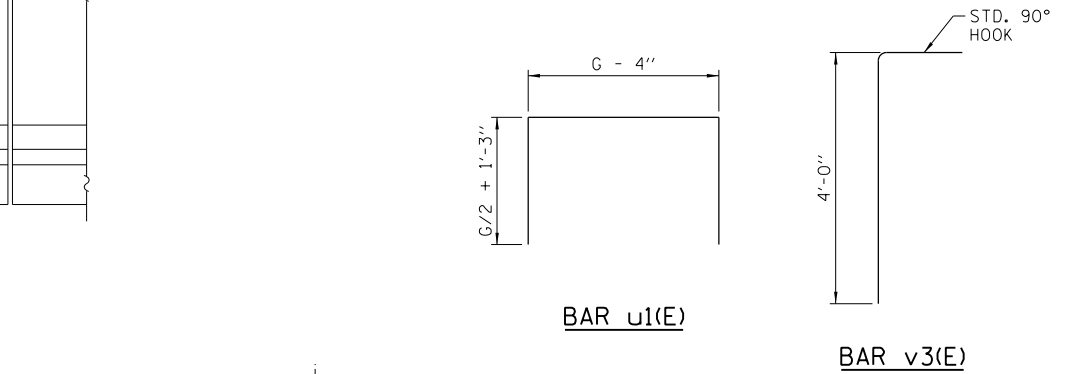

SECTION D-D

NOTES:

- SEE SHEET 6 OF THIS SERIES FOR ADDITIONAL NOTES.
- GRADE BEAM AND DRILLED SHAFT DIMENSIONS, DETAILS, QUANTITIES AND BAR LIST ARE SHOWN ON SHEET 6 OF THIS SERIES.
- SEAL EXPOSED SURFACE OF 1/4" PREFORMED JOINT FILLER WITH BACKER ROD AND SILICONE SEALER (1" DEEP AND HOLD 1/8" BELOW SURFACE OF CONCRETE).
- #5 DRILLED ANCHOR BARS WILL BE EPOXY GROUTED AASHTO M31, GRADE 60 REBAR. PROVIDE 12" MINIMUM EMBEDMENT. INSTALL ANCHORS ACCORDING TO STANDARD SPECIFICATIONS SECTION 584. LOCATE GRADE BEAM REBAR PRIOR TO DRILLING. DO NOT DAMAGE GRADE BEAM REBAR DURING INSTALLATION.
- COORDINATE CONDUIT SIZE, LOCATION AND QUANTITY WITH ELECTRICAL PLANS. CONDUITS SHALL BE PLACED TO MISS REINFORCEMENT BARS. DO NOT CUT REINFORCEMENT BARS.
- PROTECTIVE COAT SHALL BE APPLIED TO TRAFFIC AND TOP FACES OF CRASHWALL.

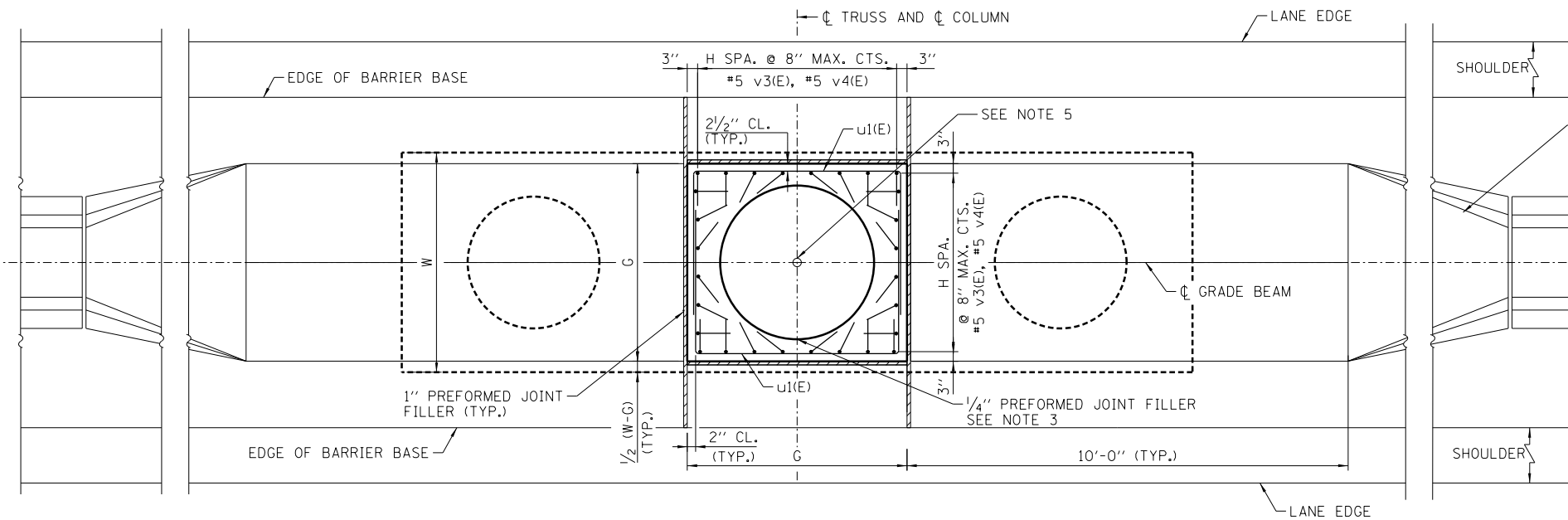

PLAN

TABLE H: DESIGN TABLE FOR CRASHWALL

SPAN LENGTH (L)	W	G	H	CLASS S1 CONCRETE CU. YD.	REINF. BARS POUND	PROTECTIVE COAT SQ. YD.
< = 20'	5'-0"	4'-6"	6	1.7	340	6.0
21'-30'	5'-0"	4'-6"	6	1.7	340	6.0
31'-40'	6'-0"	5'-0"	7	2.0	380	7.0
41'-50'	6'-0"	5'-0"	7	2.0	380	7.0



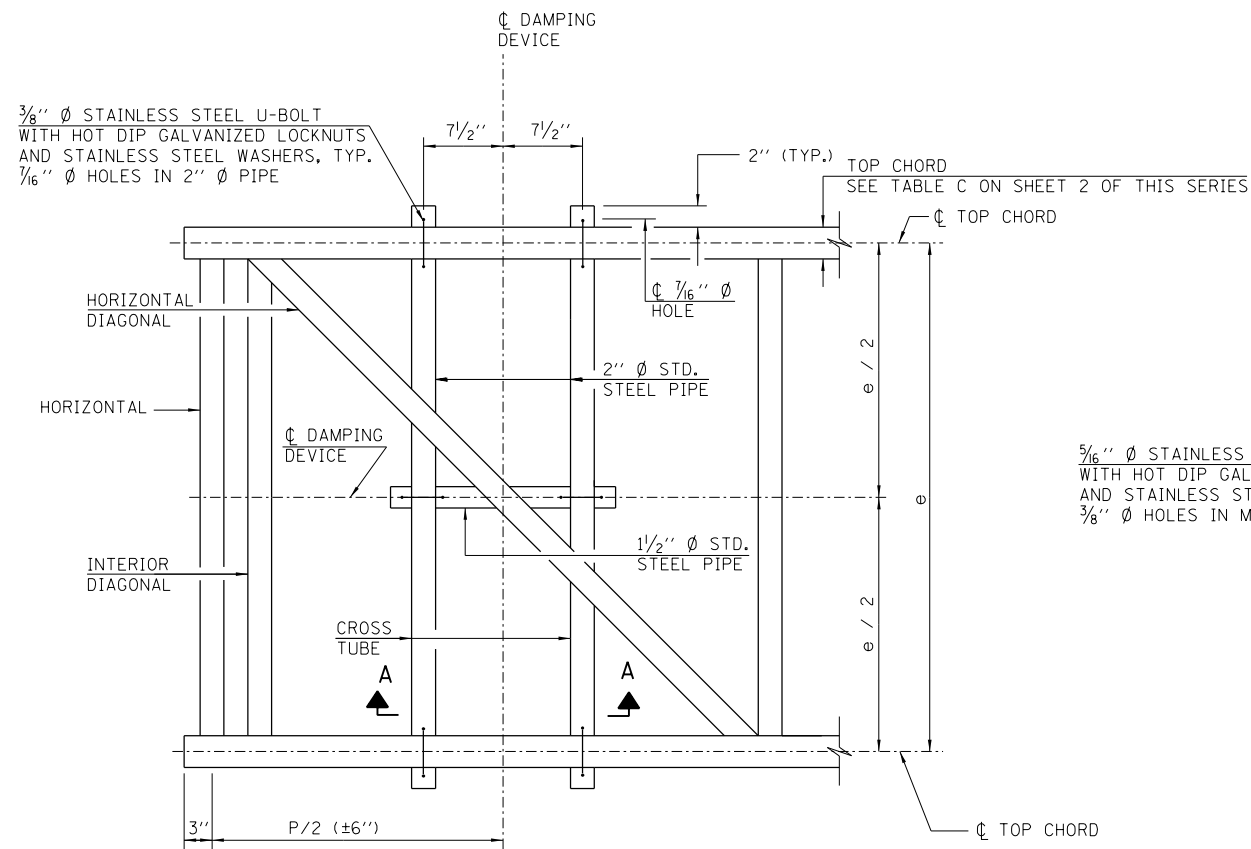

PLAN DETAIL

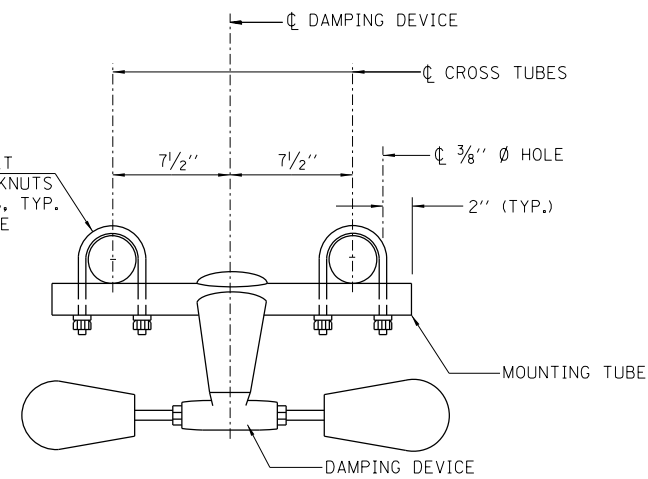

TRUSS DAMPING DEVICE CONNECTION DETAIL

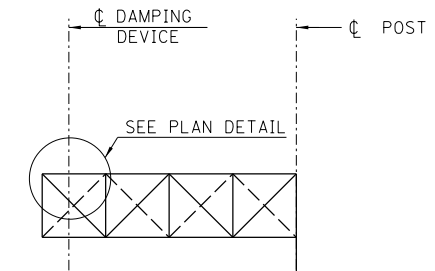

ELEVATION

NOTE:
 DAMPER: ONE DAMPER PER TRUSS. (31 LBS. STOCKBRIDGE-TYPE 29" MINIMUM BETWEEN ENDS OF WEIGHTS) COST INCLUDED IN THE COST OF "OVERHEAD SIGN STRUCTURE, CANTILEVER TYPE (STEEL)."

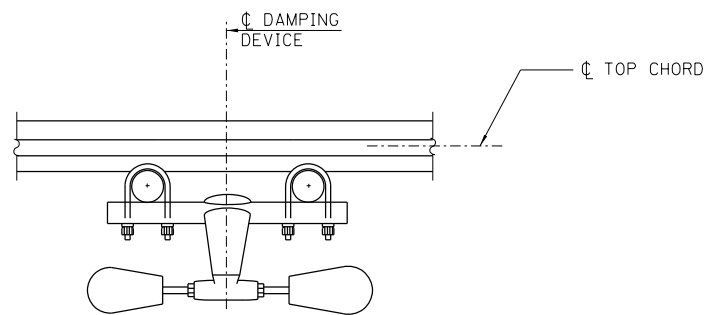

SECTION A-A

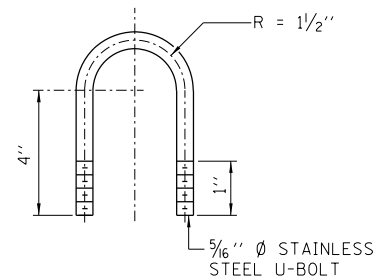

DAMPING DEVICE MOUNTING TUBE U-BOLT DETAIL (TYPICAL)

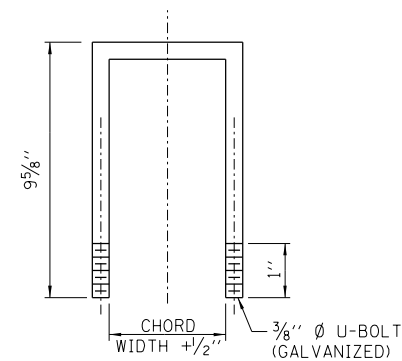

TOP CHORD TO CROSS TUBE U-BOLT DETAIL (TYPICAL)

APPROVED *Paul Kovacs* CHIEF ENGINEER DATE 3-31-2014



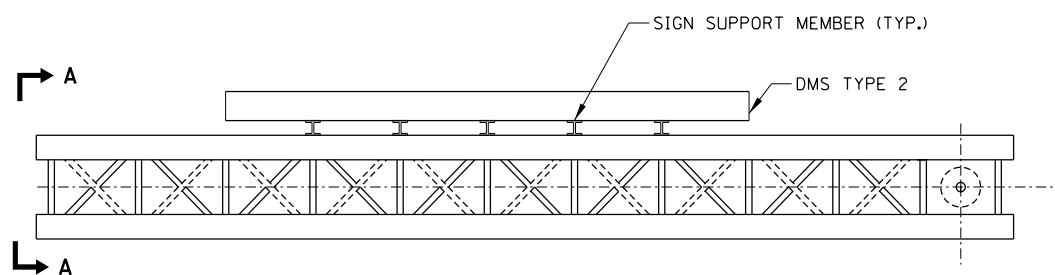

PLAN

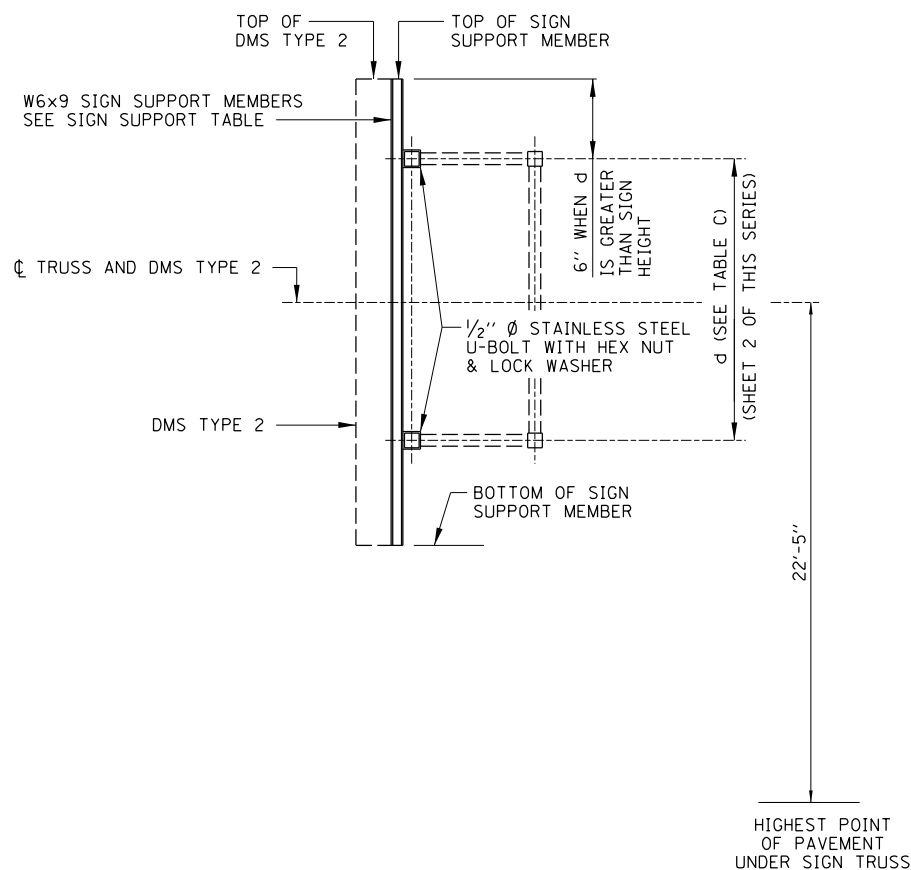

SECTION A-A

DMS TYPE 2 SUPPORT DETAIL

TABLE I: SIGN SUPPORT TABLE

SIGN WIDTH		NUMBER OF SIGN SUPPORTS REQUIRED
GREATER THAN	LESS THAN OR EQUAL TO	
	8'-0"	2
8'-0"	14'-0"	3
14'-0"	20'-0"	4
20'-0"	26'-0"	5
26'-0"	32'-0"	6

TABLE J: DMS TYPE 2 TABLE

MAXIMUM TRUSS LENGTH	MAXIMUM DMS TYPE 2 SIGN SIZE			MAXIMUM WEIGHT
	HEIGHT	WIDTH	DEPTH	
25 FEET	4'-0"	10'-0"	1'-0"	1200 LBS.
30 FEET	5'-0"	16'-0"	1'-0"	2000 LBS.
40 FEET	8'-0"	26'-0"	2'-2"	3100 LBS.

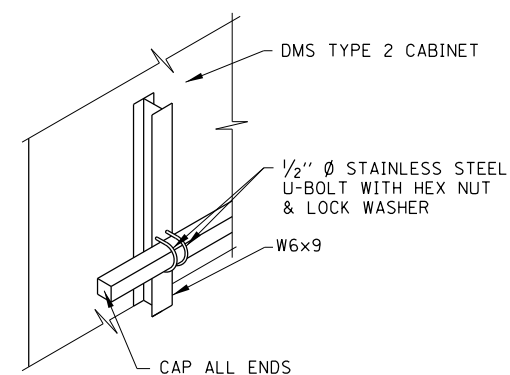

STAINLESS STEEL U-BOLT DETAIL

NOTES:

1. DMS TYPE 2 SHALL BE ATTACHED TO TRUSS AS CLOSE TO PANEL JOINTS AS POSSIBLE.
2. VERIFY SIGN SUPPORT MEMBER LENGTH PRIOR TO FABRICATION.
3. DMS TYPE 2 MANUFACTURER SHALL DESIGN, PROVIDE AND INSTALL HORIZONTAL MOUNTING MEMBERS. VERTICAL SPACING OF HORIZONTAL MEMBERS SHALL BE DESIGNED BY DMS TYPE 2 MANUFACTURER. VERIFY VERTICAL SPACING WITH HOLES FOR STAINLESS STEEL U-BOLT.
4. ALTERNATE DMS TYPE 2 DIMENSIONS MAY BE ACCEPTABLE UPON ILLINOIS TOLLWAY'S APPROVAL. CONSULT WITH THE ILLINOIS TOLLWAY BEFORE USING DMS TYPE 2 WITH ALTERNATE DIMENSIONS.



RESERVED

APPROVED..... CHIEF ENGINEER..... DATE

DATE	REVISIONS



RESERVED

STANDARD F5-00

RESERVED

APPROVED CHIEF ENGINEER DATE

DATE	REVISIONS



RESERVED

STANDARD F6-00

RESERVED

APPROVED CHIEF ENGINEER DATE

DATE	REVISIONS

RESERVED
STANDARD F7-00

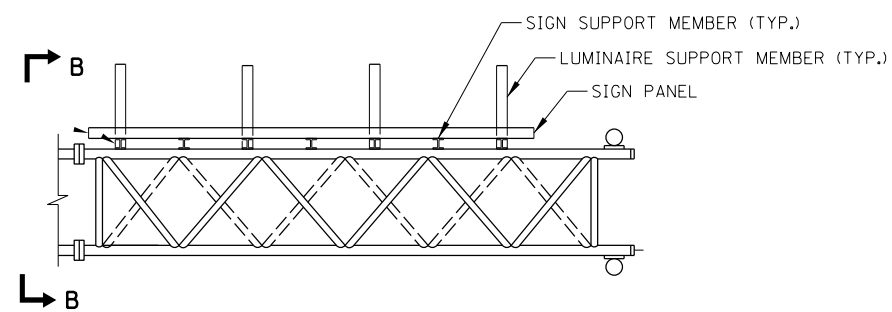
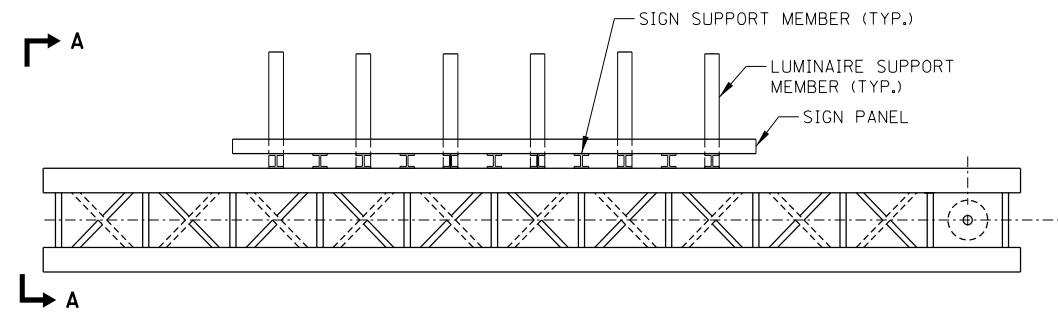

PLAN

PLAN

SIGN SUPPORT MEMBERS-WF(A-N) 4x1.79

SIGN PANEL HEIGHT	TRUSS DEPTH				
	4'-6"	5'-6"	7'-0"	8'-2"	8'-10"
17'-1" TO 18'-0"	3'-0"	3'-0"	4'-6"	5'-6"	6'-0"
16'-1" TO 17'-0"	3'-6"	4'-0"	5'-0"	6'-0"	
15'-1" TO 16'-0"	4'-0"	4'-6"		6'-0"	
14'-1" TO 15'-0"	4'-6"		6'-0"		
≤14'-0"			6'-0"		

NOTE:
SIGN PANEL WIDTH BEYOND THE OUTSIDE VERTICAL MEMBER SHALL BE LIMITED TO 1/2 OF THE MAXIMUM SPACING

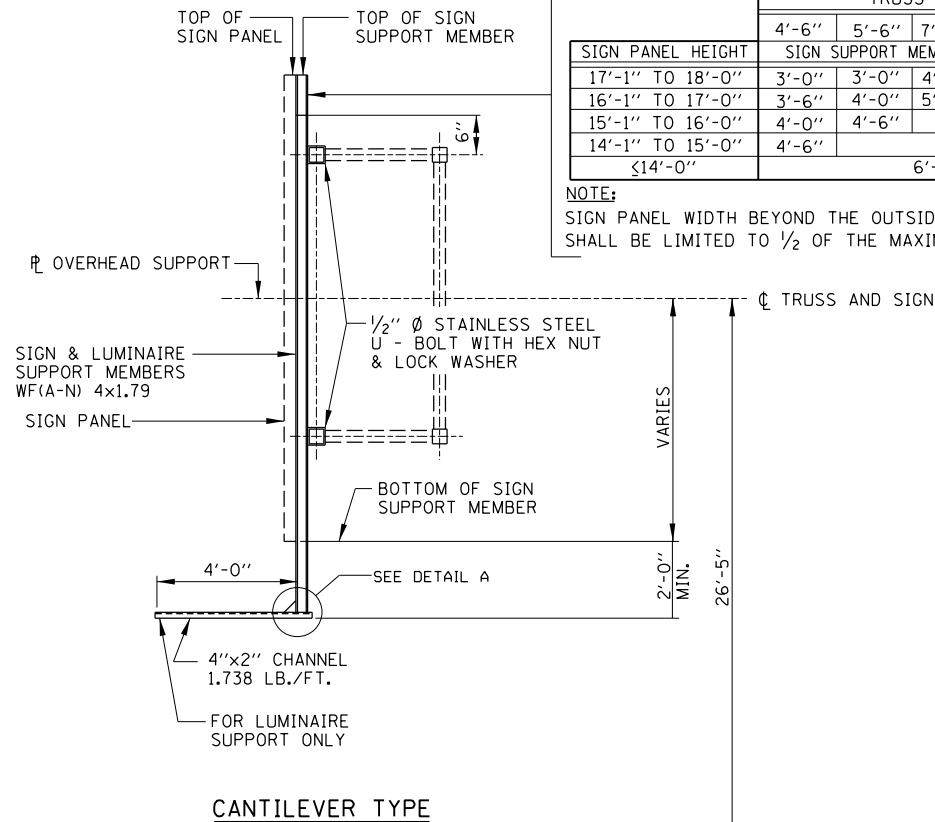

SECTION A-A

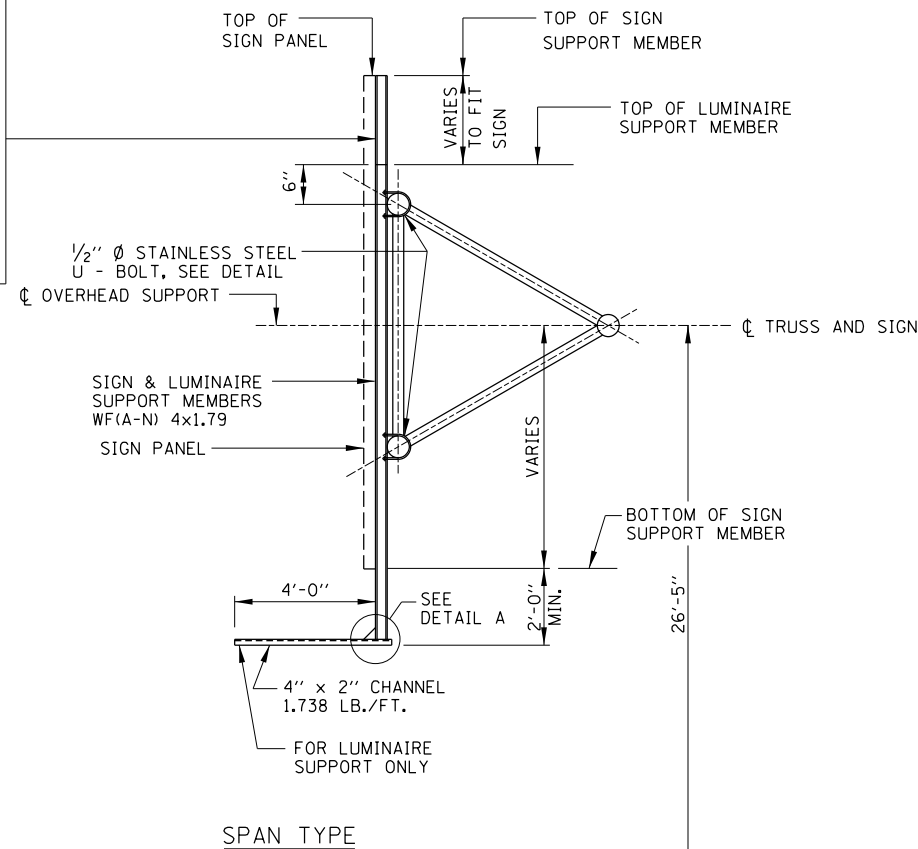

SECTION B-B

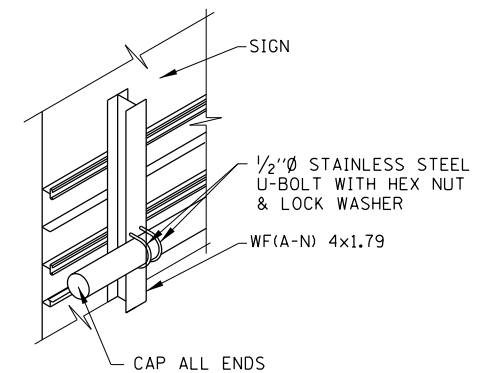

STAINLESS STEEL U-BOLT DETAIL

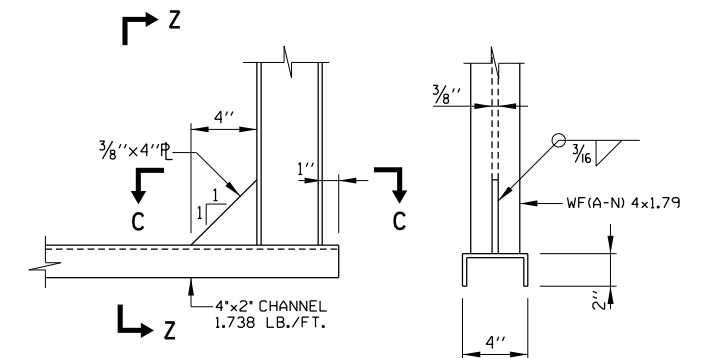

DETAIL A

SECTION Z-Z

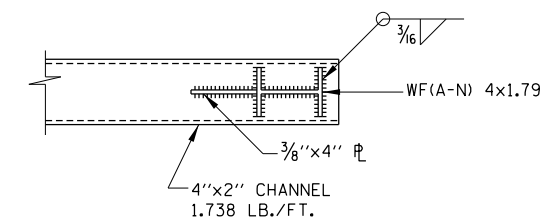

SECTION C-C

NOTES:
ALL MATERIAL IS ALUMINUM (UNLESS OTHERWISE NOTED).

NOTES:

- SIGN PANEL SHALL BE ATTACHED TO TRUSS AS CLOSE TO PANEL JOINTS AS POSSIBLE.
- LUMINAIRE SUPPORT MEMBERS TO BE INSTALLED ONLY WHEN SIGN STRUCTURE IS TO BE ILLUMINATED. DESIGNER TO DETERMINE REQUIREMENTS BASED ON ROADWAY GEOMETRY.

APPROVED *Paul Kovacs* DATE 2-7-2012
CHIEF ENGINEER

DATE	REVISIONS
1-1-2009	ADDED PLAN VIEWS FOR SIGN STRUCTURES
2-7-2012	REVISED OVERHEAD SIGN STRUCTURE CANTILEVER DIAGONALS
2-1-2013	REMOVED VERTICAL CLEARANCE.
3-31-2014	REVISED SIGN SUPPORT MEMBERS
3-11-2015	REVISED VERTICAL CL. AND SIGN SUPPORT



OVERHEAD SIGN STRUCTURE
SIGN AND LUMINAIRE
SUPPORTS

STANDARD F8-05

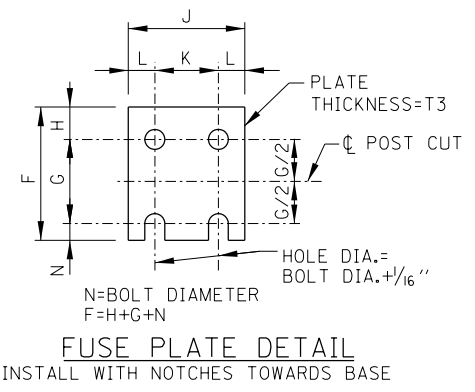
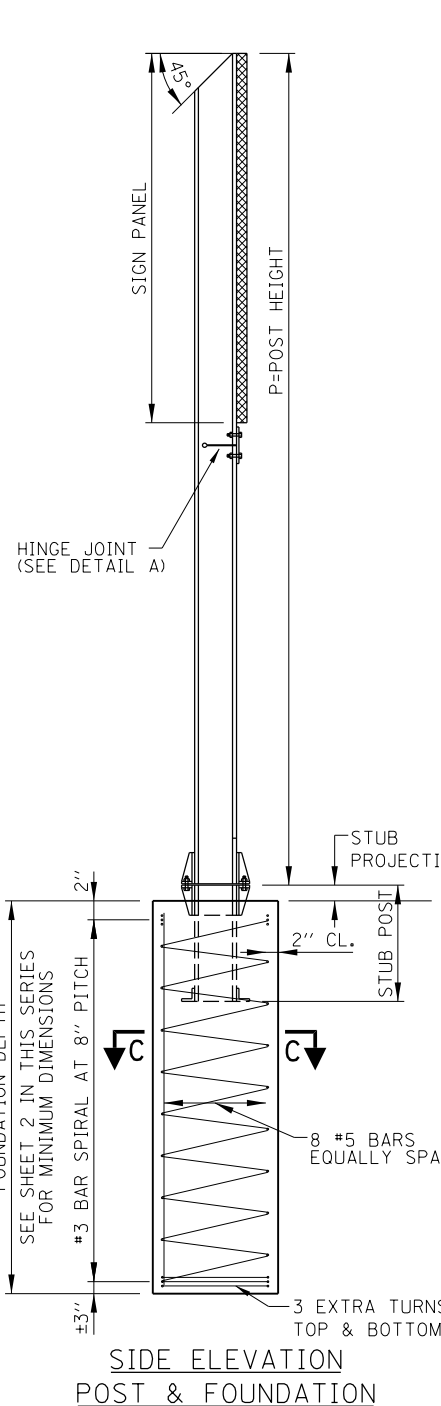

G & H DIM. TABLE

BOLT DIA.	G	H
1/2"	2"	1 1/8"
5/8"	2 1/4"	1 1/4"
3/4"	2 1/2"	1 3/8"
7/8"	2 3/4"	1 1/2"
1"	3"	1 5/8"
1 1/8"	3 1/4"	1 3/4"
1 1/4"	3 1/2"	1 7/8"

FABRICATORS NOTES

THE SLOT AND THE 5/8" DIA. HOLE IN THE WEB AND THE FUSE PLATE BOLT HOLES IN THE FLANGE SHALL BE MADE BEFORE GALVANIZING. POST FLANGE SHALL BE SAW CUT AFTER GALVANIZING AND BARE METAL SURFACES SHALL BE COATED WITH AN APPROVED ZINC SOLDER OR ZINC-RICH PAINT. THESE SURFACES SHALL NOT BE COATED UNTIL THE FUSE PLATE IS INSTALLED AND BOLTS FULLY TIGHTENED.

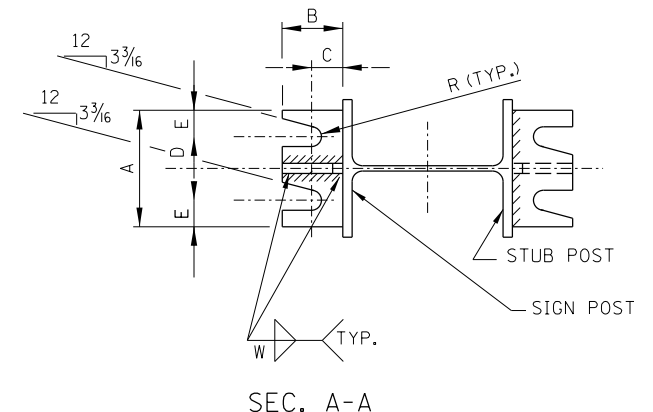
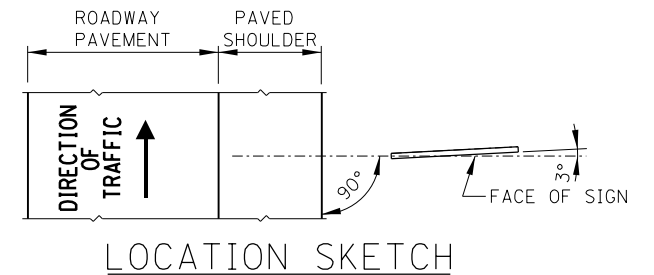
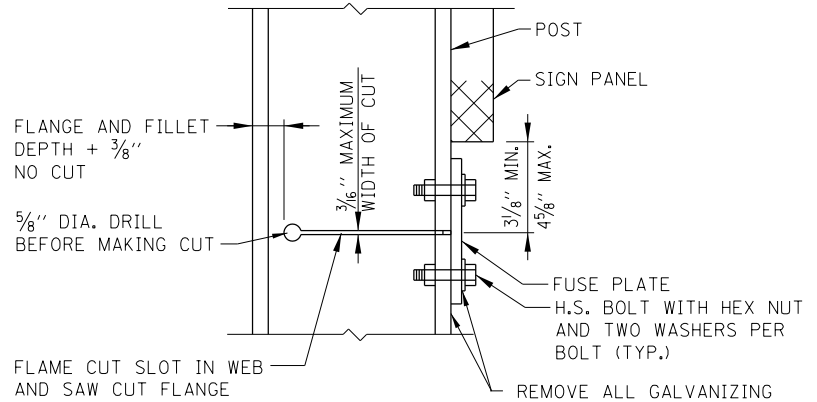

GENERAL NOTES

DESIGN: THE LATEST EDITION OF THE "AASHTO STANDARD SPECIFICATIONS FOR STRUCTURAL SUPPORTS FOR HIGHWAY SIGNS, LUMINAIRE AND TRAFFIC SIGNALS".

CONSTRUCTION: STANDARD SPECIFICATIONS AND THE SPECIAL PROVISIONS.

LOADING: FOR 80 MPH WIND VELOCITY PLUS 30% GUST FACTOR NORMAL TO SIGN.

DESIGN STRESSES:
 STRUCTURAL STEEL - PER AASHTO 20,000 P.S.I.
 REINFORCING STEEL - 24,000 P.S.I.
 CLASS SI CONCRETE - 1,400 P.S.I.
 MINIMUM SOIL PRESSURE - 1.25 TONS/SQ. FT.

WELDING: ALL WELDING TO BE CONTINUOUS UNLESS OTHERWISE SHOWN. ALL WELDING TO BE DONE IN ACCORDANCE WITH CURRENT AWS SPECIFICATIONS, AND STANDARD SPECIFICATIONS.

MATERIALS: ALL STRUCTURAL STEEL SHALL CONFORM TO ASTM A36 AND STANDARD SPECIFICATIONS.

ALL HIGH STRENGTH STEEL BOLTS, NUTS AND WASHERS SHALL CONFORM TO STANDARD SPECIFICATIONS.

HIGH STRENGTH STEEL BOLTS, NUTS AND HARDENED WASHERS SHALL BE GALVANIZED IN ACCORDANCE WITH AASHTO M232.

HIGH STRENGTH BOLTS IN BASE PLATES SHALL BE TIGHTENED TO THE TORQUE SHOWN ON SHEET 2 IN THIS SERIES.

AFTER FABRICATION, THE POST, FUSE PLATE, BASE PLATE AND UPPER 6" OF STUB POST SHALL BE HOT-DIP GALVANIZED ACCORDING TO ASTM M111, EXCEPT AS NOTED UNDER FABRICATOR NOTES.

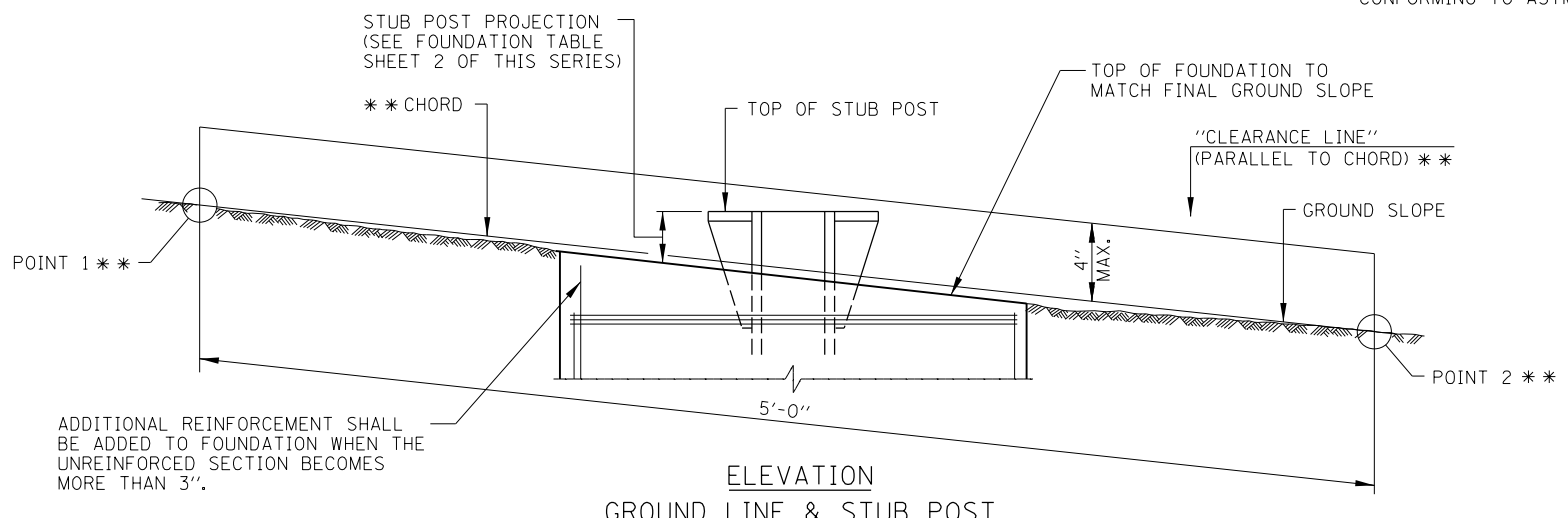
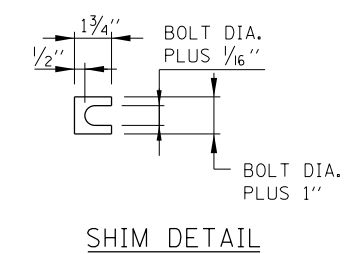
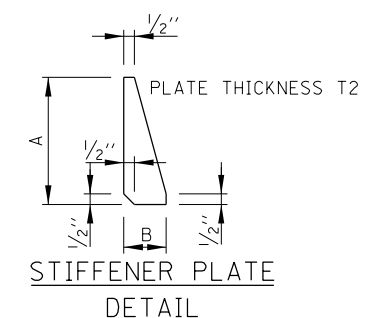
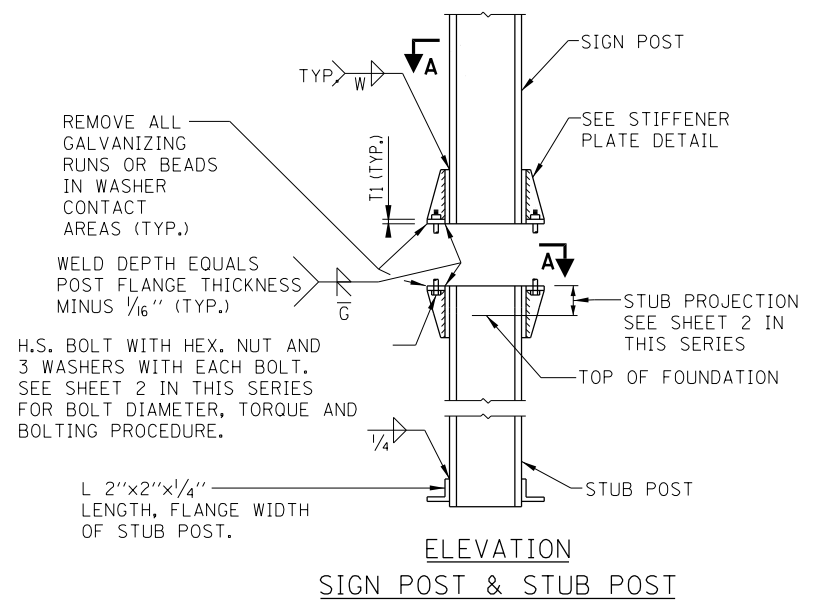

** FOR ALL "POINT 1" AND "POINT 2" LOCATIONS, "CLEARANCE LINE" MUST BE AT OR ABOVE TOP OF STUB POST.

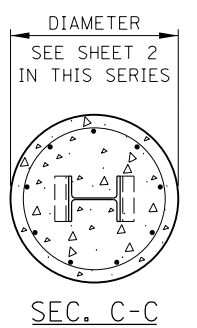

APPROVED *Paul Kovacs* CHIEF ENGINEER DATE 1-1-2010

DATE	REVISIONS
2-7-2012	ADDED STUB POST CLEARANCE DIMENSIONS, REVISED SIGN INSTALLATION CLEARANCE DIMENSIONS
11-1-2012	REVISED NOTES, MODIFIED SLOPE REQUIREMENTS FOR BREAKAWAY SUPPORTS

SHEET 1 OF 4

BREAKAWAY SIGN SUPPORT DETAILS

STANDARD F9-04

POST	FOUNDATION TABLE											BASE CONNECTION DATA TABLE												
	FOUNDATION			REINFORCEMENT					STUB POST			BOLT SIZE AND TORQUE	A	B	C	D	E	T1	T2	W	R			
	DIA.	MIN. DEPTH	CY.* CONC.	VERTICAL NO.	BARS SIZE	LGTH.	BAR SPIRALS SIZE	O.D.	LGTH.	LBS.**	STUB LGTH.											STUB PROJECTION	LBS.***	
W6x9	2'-0"	6'-0"	.70	8	#5	5'-9"	#3	20 1/2"	79'	78	2'-3"	3"	44	5/8" Ø x 3 1/4" LG. TORQUE = 450" #	6"	2 1/4"	1 1/4"	3 1/2"	1 1/4"	3/4"	1/2"	1/4"	1 1/32"	
W6x15	2'-0"	6'-0"	.70	8	#5	5'-9"	#3	20 1/2"	79'	78	2'-6"	3"	71											
W8x18	2'-0"	6'-0"	.70	8	#5	5'-9"	#3	20 1/2"	79'	78	2'-6"	3"	85	3/4" Ø x 3 3/4" LG. TORQUE = 750" #	6"	2 1/2"	1 3/8"	3 1/4"	1 3/8"	1"	1/2"	5/16"	1 1/32"	
W10x22	2'-6"	6'-6"	1.18	8	#5	6'-3"	#3	26 1/2"	105'	92	3'-0"	2 1/2"	110											
W10x26	2'-6"	7'-0"	1.27	8	#5	6'-9"	#3	26 1/2"	112'	98	3'-0"	2 1/2"	137											
W12x26	2'-6"	7'-9"	1.41	8	#5	7'-6"	#3	26 1/2"	119'	107	3'-0"	2 1/2"	140	7/8" Ø x 4" LG. TORQUE = 950" #	7"	2 3/4"	1 1/2"	4"	1 1/2"	1"	3/4"	3/8"	1 5/32"	
W14x30	3'-0"	7'-3"	1.90	8	#5	7'-0"	#3	32 1/2"	145'	113	3'-0"	2 1/2"	150											
W14x38	3'-0"	8'-0"	2.09	8	#5	7'-9"	#3	32 1/2"	153'	122	3'-6"	2 1/2"	208	1" Ø x 4 1/2" LG. TORQUE = 1100" #	7 1/2"	3"	1 3/4"	4"	1 3/4"	1 1/4"	3/4"	3/8"	1 1/32"	
W16x45	3'-0"	8'-6"	2.23	8	#5	8'-3"	#3	32 1/2"	162'	130	3'-6"	2 1/2"	233											

PROCEDURE FOR ASSEMBLY OF BASE CONNECTION:

1. ASSEMBLE POST TO STUB WITH H.S. BOLTS AND ONE OF THE THREE FLAT WASHERS ON EACH BOLT BETWEEN PLATES AS SHOWN.
2. SHIMS MAY BE USED BETWEEN PLATES TO LEVEL POST.
3. TIGHTEN BOLTS IN BASE PLATE IN A SYSTEMATIC ORDER TO THE REQUIRED TORQUE.
4. LOOSEN EACH BOLT AND RETIGHTEN TO THE REQUIRED TORQUE IN SAME ORDER AS INITIAL TIGHTENING.
5. BURR OR CENTER PUNCH THREADS AT JUNCTURE OF BOLT AND NUT TO PREVENT NUT FROM LOOSENING.

- * QUANTITY OF CLASS SI CONCRETE CONSISTS OF ALL CONCRETE NECESSARY FOR ONE FOUNDATION. (CUBIC YARDS)
- ** THIS INCLUDES REINFORCEMENT BARS AND SPIRAL HOOPING REQUIRED FOR ONE FOUNDATION.
- *** INCLUDES WEIGHT OF STUB POST WITH ANGLES, GUSSETS, BASE PLATES, BOLTS, NUTS, WASHERS, PLUS BASE PLATES AND GUSSETS ON MAIN POST, PLUS FUSE PLATE (IF ANY) WITH BOLTS, NUTS AND WASHERS. (ONE POST)

EQUIVALENT TORQUE VALUES

450" # = 37.5' #
750" # = 62.5' #
950" # = 79.2' #
1100" # = 91.7' #

POST	FUSE PLATE DATA TABLE				FUSE PLATE BOLT SIZE TABLE											
	J	K	L	T3	SIGN DEPTH											
					4'	5'	6'	7'	8'	9'	10'	11'	12'	13'	14'	
W6x9	4"	2 1/4"	7/8"	1/4"	1/2"Øx1 1/2"	1/2"Øx1 1/2"	1/2"Øx1 1/2"	5/8"Øx1 3/4"	5/8"Øx1 3/4"	5/8"Øx1 3/4"	---	---	---	---	---	
W6x15	6"	3 1/2"	1 1/4"	3/8"	1/2"Øx1 3/4"	1/2"Øx1 3/4"	5/8"Øx2"	5/8"Øx2"	3/4"Øx2"	3/4"Øx2"	3/4"Øx2"	3/4"Øx2"	7/8"Øx2"	7/8"Øx2"	---	
W8x18	5 1/4"	2 3/4"	1 1/4"	3/8"	1/2"Øx1 3/4"	1/2"Øx1 3/4"	1/2"Øx1 3/4"	5/8"Øx2"	5/8"Øx2"	3/4"Øx2"	3/4"Øx2"	7/8"Øx2 1/4"	7/8"Øx2 1/4"	7/8"Øx2 1/4"	7/8"Øx2 1/4"	
W10x22	5 3/4"	2 3/4"	1 1/2"	1/2"	1/2"Øx2"	1/2"Øx2"	1/2"Øx2"	5/8"Øx2"	5/8"Øx2"	3/4"Øx2 1/4"	3/4"Øx2 1/4"	7/8"Øx2 1/4"	7/8"Øx2 1/4"	7/8"Øx2 1/2"	1"Øx2 1/2"	
W10x26	5 3/4"	2 3/4"	1 1/2"	5/8"	1/2"Øx2"	1/2"Øx2"	1/2"Øx2"	5/8"Øx2 1/4"	5/8"Øx2 1/4"	3/4"Øx2 1/2"	3/4"Øx2 1/2"	7/8"Øx2 1/2"	7/8"Øx2 1/2"	1"Øx2 3/4"	1"Øx2 3/4"	
W12x26	6 1/2"	3 1/2"	1 1/2"	5/8"	---	---	---	---	---	5/8"Øx 2 1/4"	---	---	7/8"Øx2 1/2"	7/8"Øx2 1/2"	1"Øx2 1/2"	
W14x30	6 3/4"	3 1/2"	1 5/8"	1/2"	1/2"Øx2"	1/2"Øx2"	1/2"Øx2"	1/2"Øx2"	1/2"Øx2"	5/8"Øx2 1/4"	5/8"Øx2 1/4"	3/4"Øx2 1/4"	3/4"Øx2 1/4"	7/8"Øx2 1/2"	1"Øx2 1/2"	
W14x38	6 3/4"	3 1/2"	1 5/8"	1/2"	---	1/2"Øx2"	1/2"Øx2"	1/2"Øx2"	1/2"Øx2"	5/8"Øx2 1/4"	5/8"Øx2 1/4"	3/4"Øx2 1/2"	3/4"Øx2 1/2"	7/8"Øx2 1/2"	7/8"Øx2 1/2"	
W16x45	7"	3 1/2"	1 3/4"	1/2"	---	---	---	1/2"Øx2"	1/2"Øx2"	5/8"Øx2 1/4"	5/8"Øx2 1/4"	3/4"Øx2 1/2"	3/4"Øx2 1/2"	7/8"Øx2 1/2"	7/8"Øx2 1/2"	

POST	FUSE PLATE DATA TABLE				FUSE PLATE BOLT SIZE TABLE											
	J	K	L	T3	SIGN DEPTH											
					15'	16'	17'	18'	19'	20'	21'	22'	23'	24'	---	
W6x9	4"	2 1/4"	7/8"	1/4"	---	---	---	---	---	---	---	---	---	---	---	
W6x15	6"	3 1/2"	1 1/4"	3/8"	---	---	---	---	---	---	---	---	---	---	---	
W8x18	5 1/4"	2 3/4"	1 1/4"	3/8"	7/8"Øx2 1/4"	7/8"Øx2 1/4"	---	---	---	---	---	---	---	---	---	
W10x22	5 3/4"	2 3/4"	1 1/2"	1/2"	1"Øx2 3/4"	1"Øx2 3/4"	1"Øx2 3/4"	1"Øx2 3/4"	1"Øx2 3/4"	1"Øx2 3/4"	---	---	---	---	---	
W10x26	5 3/4"	2 3/4"	1 1/2"	5/8"	1"Øx2 3/4"	1 1/8"Øx3"	1 1/8"Øx3"	1 1/4"Øx3"	1 1/4"Øx3"	1 1/4"Øx3"	1 1/4"Øx3"	1 1/4"Øx3"	1 1/4"Øx3"	1 1/4"Øx3"	---	
W12x26	6 1/2"	3 1/2"	1 1/2"	5/8"	1"Øx2 3/4"	1"Øx2 3/4"	1 1/8"Øx3"	1 1/4"Øx3"	1 1/4"Øx3"	1 1/4"Øx3"	1 1/4"Øx3"	1 1/4"Øx3"	1 1/4"Øx3"	1 1/4"Øx3"	---	
W14x30	6 3/4"	3 1/2"	1 5/8"	1/2"	1"Øx2 3/4"	1"Øx2 3/4"	1 1/4"Øx3"	1 1/4"Øx3"	1 1/4"Øx3"	1 1/4"Øx3"	1 1/4"Øx3"	1 1/4"Øx3"	1 1/4"Øx3"	1 1/4"Øx3"	---	
W14x38	6 3/4"	3 1/2"	1 5/8"	1/2"	1"Øx2 1/2"	1"Øx2 3/4"	1 1/4"Øx3"	1 1/4"Øx3"	1 1/4"Øx3"	1 1/4"Øx3"	1 1/4"Øx3"	1 1/4"Øx3"	1 1/4"Øx3"	1 1/4"Øx3"	---	
W16x45	7"	3 1/2"	1 3/4"	1/2"	7/8"Øx2 1/2"	1"Øx2 3/4"	1"Øx2 3/4"	1 1/8"Øx3"	1 1/4"Øx3"	1 1/4"Øx3"	1 1/4"Øx3"	1 1/4"Øx3"	1 1/4"Øx3"	1 1/4"Øx3"	---	

PROCEDURE FOR FUSE PLATE BOLT TIGHTENING:

ALL FRICTION FUSE BOLTS SHALL BE TIGHTENED IN THE SHOP AS APPROVED BY THE ENGINEER ACCORDING TO ONE OF THE FOLLOWING METHODS:

1. TURN-OF-NUT TIGHTENING,
2. TIGHTENING BY USE OF A DIRECT TENSION INDICATOR.

THE ABOVE METHODS OF INSTALLATION AND TIGHTENING SHALL CONFORM TO THE LATEST ISSUE OF THE SPECIFICATION FOR STRUCTURAL JOINTS USING ASTM A-325 OR A-490 BOLTS, FOR SLIP-CRITICAL CONNECTIONS AS ISSUED BY THE RESEARCH COUNCIL ON RIVETED AND BOLTED STRUCTURAL JOINTS OF THE ENGINEERING FOUNDATION.

TIGHTENING SHALL BE TO SUCH A DEGREE AS TO OBTAIN THE FOLLOWING MINIMUM RESIDUAL TENSION IN EACH BOLT.

BOLT DIA.	MIN. RESIDUAL BOLT TENSION	BOLT DIA.	MIN. RESIDUAL BOLT TENSION	BOLT DIA.	MIN. RESIDUAL BOLT TENSION
1/2"	12,050	7/8"	39,250	1 1/4"	71,700
5/8"	19,200	1"	51,500		
3/4"	28,400	1 1/8"	56,450		



APPROVED *Paul Kovacs* DATE 1-1-2010
CHIEF ENGINEER

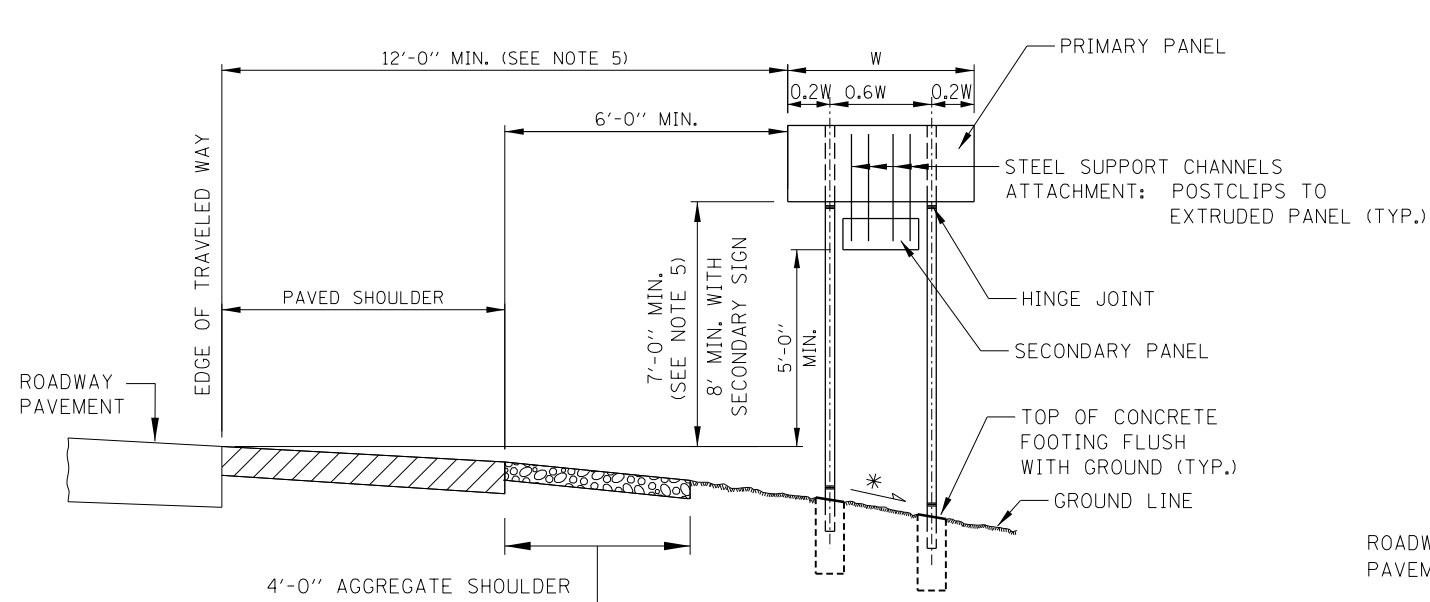

CONDITION 1 - SIGN INSTALLATION

(*) FORESLOPE 1:6 (V:H) OR FLATTER

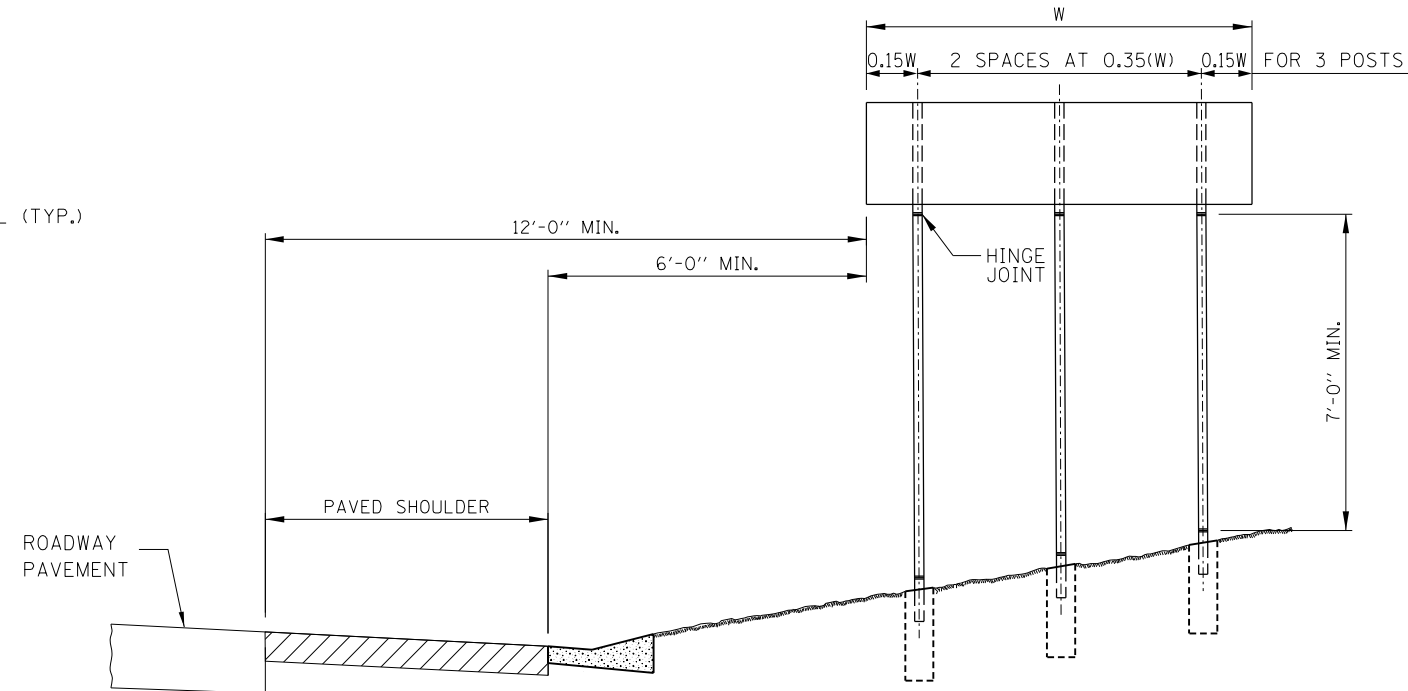

CONDITION 3 - SIGN INSTALLATION

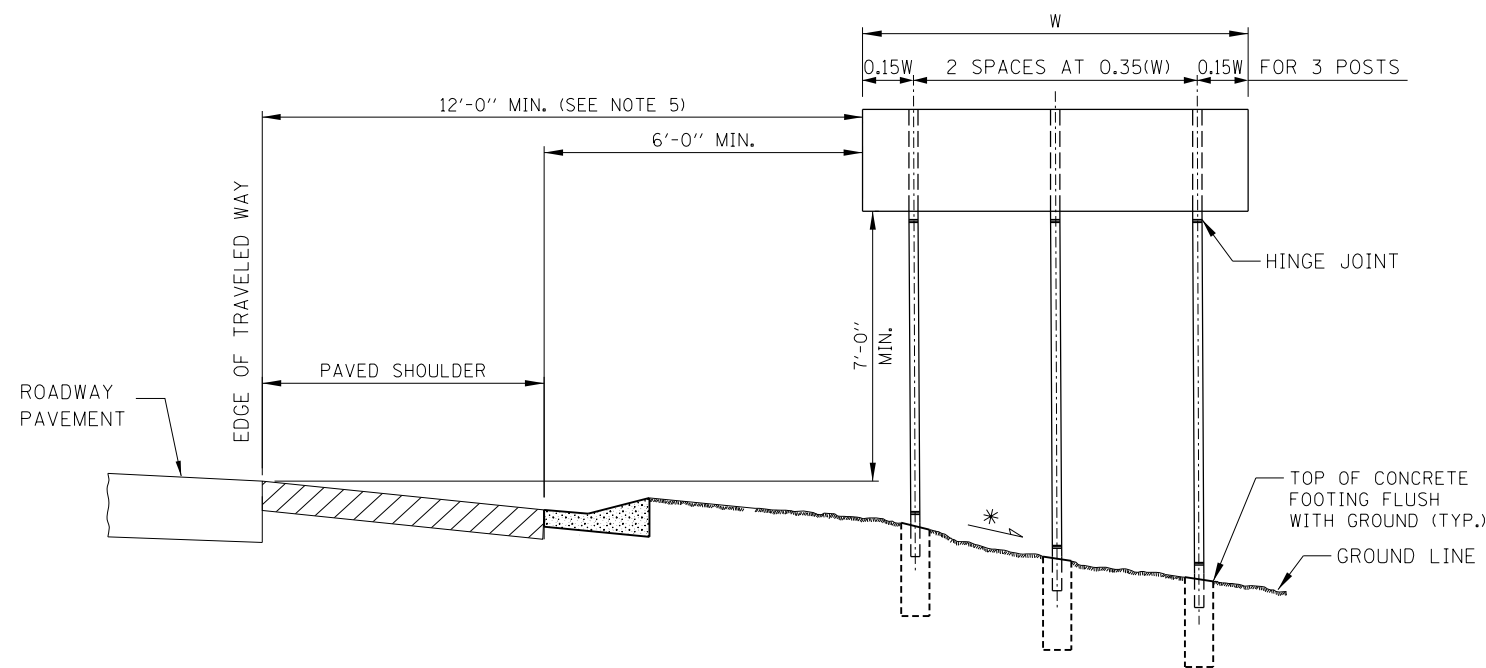

CONDITION 2 - SIGN INSTALLATION

(*) FORESLOPE 1:6 (V:H) OR FLATTER

NOTES:

1. SEE SIGN INSTALLATION SCHEDULE IN CONTRACT PLANS FOR DIMENSIONS.
2. THE DIMENSIONS OF ALL POSTS FOR GROUND MOUNTED SIGNS ARE BASED ON DESIGN CROSS SECTIONS. THE CONTRACTOR SHALL VERIFY REQUIRED POST LENGTHS IN THE FIELD, PRIOR TO SUBMITTING SHOP DRAWINGS AND POST FABRICATION TO MAINTAIN THE CLEARANCES SHOWN.
3. SIGN FOUNDATION ELEVATIONS TO BE BASED ON FINISHED SLOPES.
4. ANY ADDITIONAL SIGN TO BE ADDED LATER MUST BE SUPPORTED BY THE EXISTING SIGN PANEL AND NOT THE SIGN POST. MINIMUM CLEARANCES SHALL BE MAINTAINED.
5. SIGNS THAT ARE PLACED WELL OUTSIDE THE CLEAR ZONE MAY BE INSTALLED WITH A MINIMUM HEIGHT OF 5 FEET, MEASURED VERTICALLY FROM THE BOTTOM OF THE SIGN TO THE HORIZONTAL ELEVATION OF THE NEAR EDGE OF TRAVELED ROADWAY.
6. MINIMUM HEIGHT OF LOWEST POST SHALL BE 7'-0" MEASURED BETWEEN STUB PROJECTION AND HINGE JOINT.
7. FOR TWO POSTS SPACED LESS THAN 7 FEET APART, EACH POST SHALL HAVE A MASS LESS THAN 18 lb/ft.
8. WHEN THE TOTAL COMBINED WEIGHT OF THE TWO POSTS LOCATED WITHIN 7 FEET OF EACH OTHER EXCEEDS 600 lbs., THE SIGN SHALL BE PLACED WELL OUTSIDE THE CLEAR ZONE OR BE SHIELDED FROM VEHICULAR IMPACT.

UNSHIELDED SLOPE



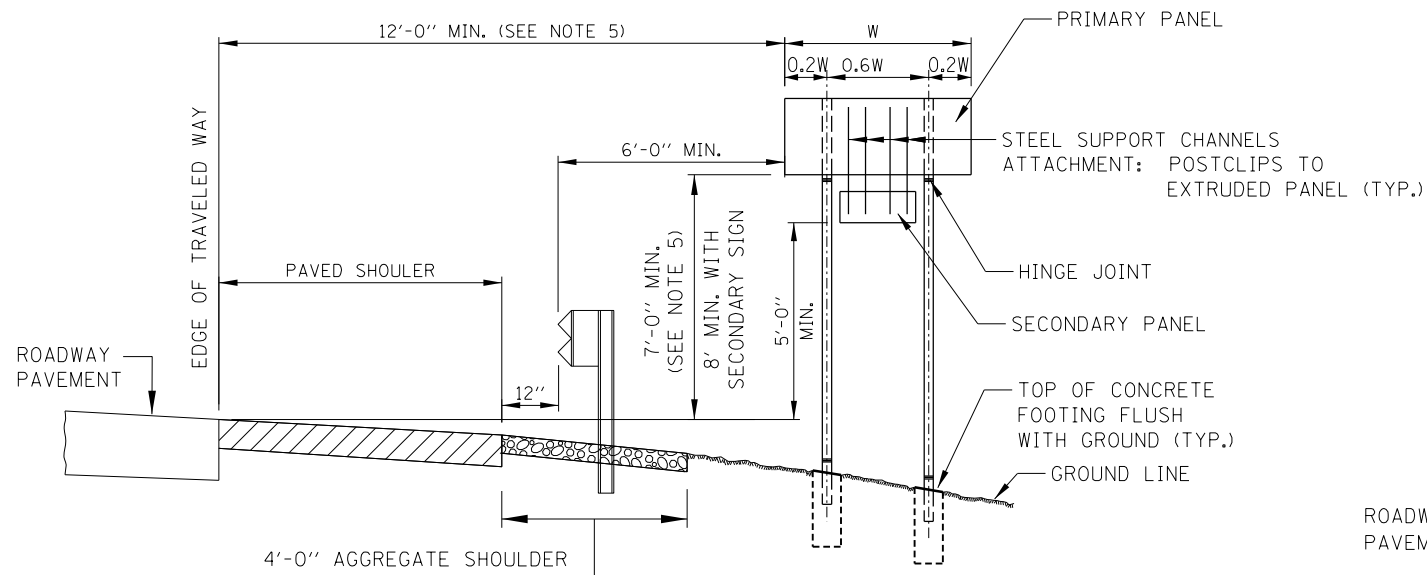

CONDITION 1 - SIGN INSTALLATION

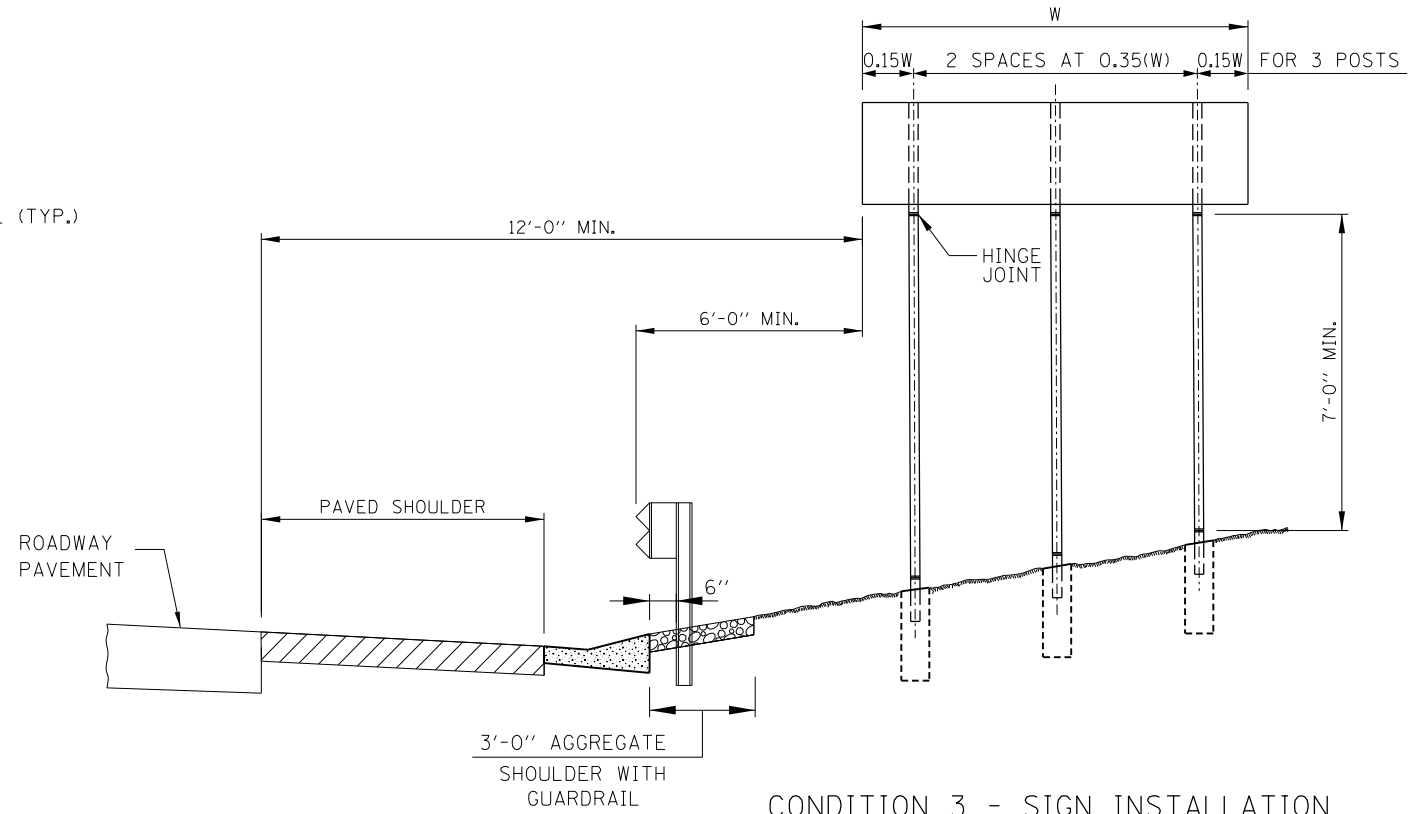

CONDITION 3 - SIGN INSTALLATION

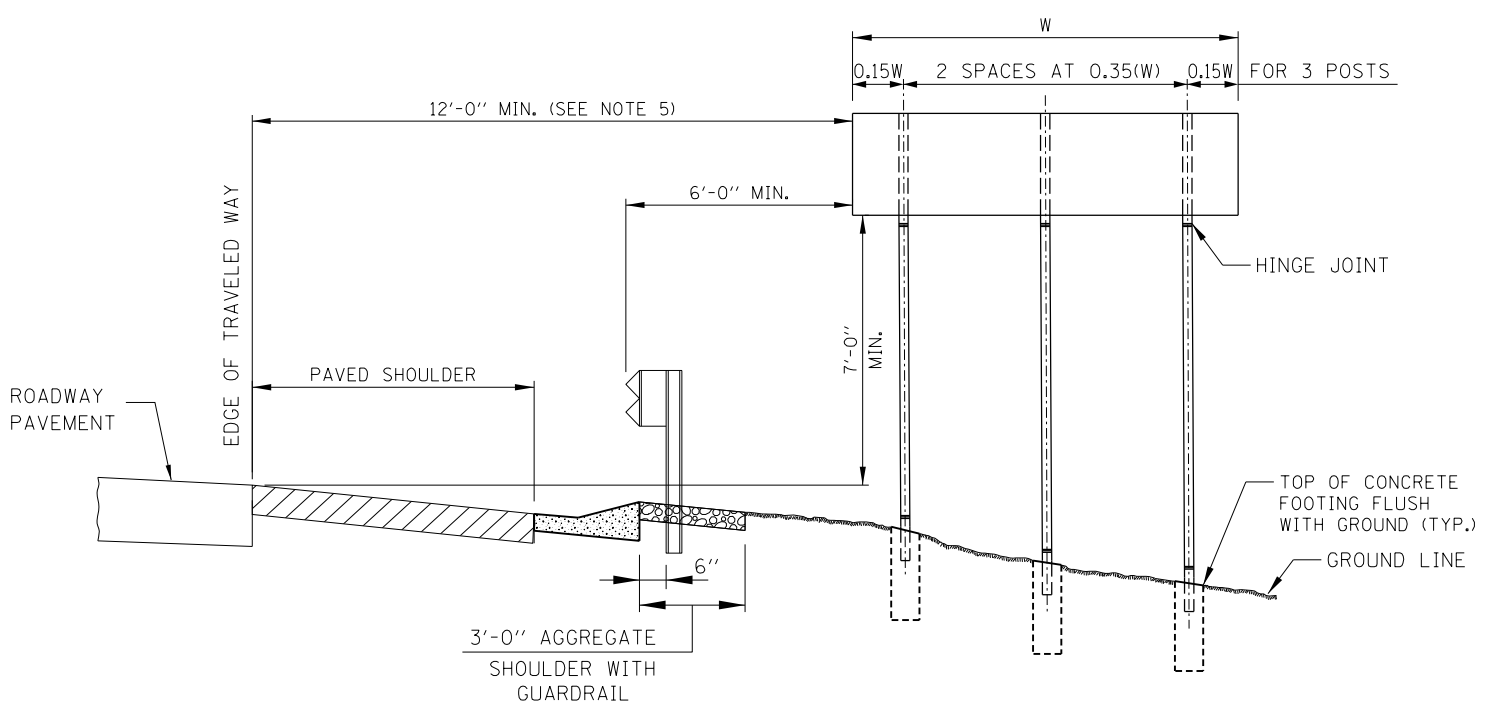

CONDITION 2 - SIGN INSTALLATION

SHIELDED SLOPE

NOTES:

1. SEE SIGN INSTALLATION SCHEDULE IN CONTRACT PLANS FOR DIMENSIONS.
2. THE DIMENSIONS OF ALL POSTS FOR GROUND MOUNTED SIGNS ARE BASED ON DESIGN CROSS SECTIONS. THE CONTRACTOR SHALL VERIFY REQUIRED POST LENGTHS IN THE FIELD, PRIOR TO SUBMITTING SHOP DRAWINGS AND POST FABRICATION TO MAINTAIN THE CLEARANCES SHOWN.
3. SIGN FOUNDATION ELEVATIONS TO BE BASED ON FINISHED SLOPES.
4. ANY ADDITIONAL SIGN TO BE ADDED LATER MUST BE SUPPORTED BY THE EXISTING SIGN PANEL AND NOT THE SIGN POST. MINIMUM CLEARANCES SHALL BE MAINTAINED.
5. SIGNS THAT ARE PLACED WELL OUTSIDE THE CLEAR ZONE MAY BE INSTALLED WITH A MINIMUM HEIGHT OF 5 FEET, MEASURED VERTICALLY FROM THE BOTTOM OF THE SIGN TO THE HORIZONTAL ELEVATION OF THE NEAR EDGE OF TRAVELED ROADWAY.
6. MINIMUM HEIGHT OF LOWEST POST SHALL BE 7'-0" MEASURED BETWEEN STUB PROJECTION AND HINGE JOINT.
7. FOR TWO POSTS SPACED LESS THAN 7 FEET APART, EACH POST SHALL HAVE A MASS LESS THAN 18 lb/ft.
8. WHEN THE TOTAL COMBINED WEIGHT OF THE TWO POSTS LOCATED WITHIN 7 FEET OF EACH OTHER EXCEEDS 600 lbs., THE SIGN SHALL BE PLACED WELL OUTSIDE THE CLEAR ZONE OR BE SHIELDED FROM VEHICULAR IMPACT.



APPROVED *Paul Kovacs* CHIEF ENGINEER DATE 1-1-2010

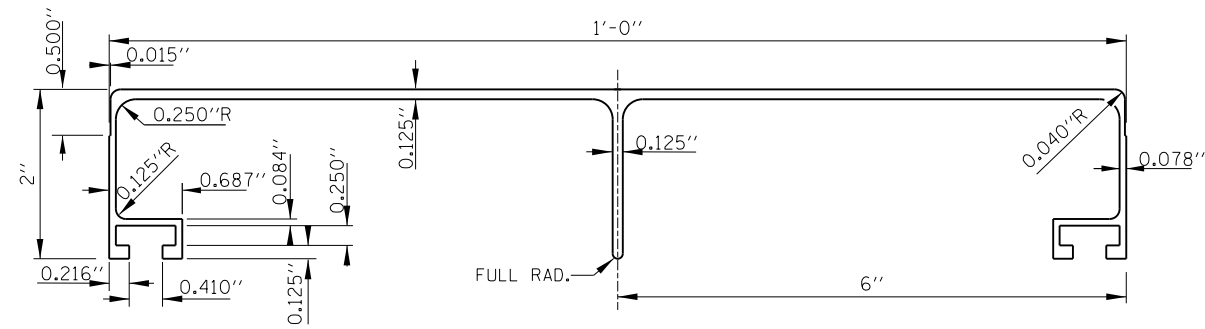

12" PANEL
TYPE B SIGN PANEL EXTRUSIONS

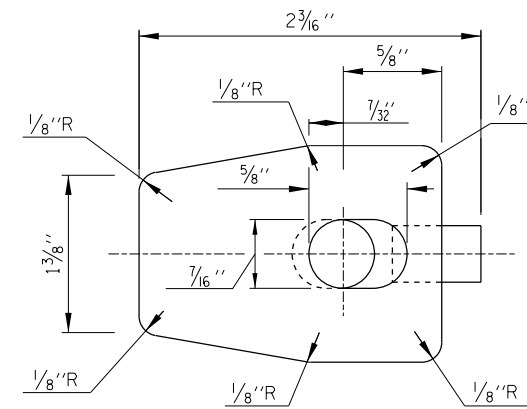

PLAN VIEW

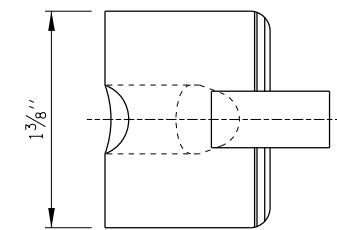

END VIEW

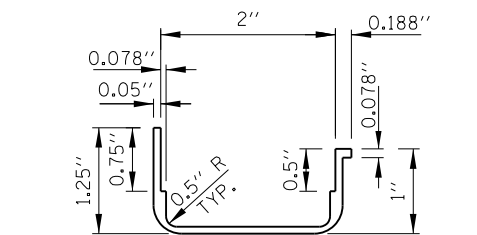

EDGE MOLDING SECTION
FOR SIGN PANEL

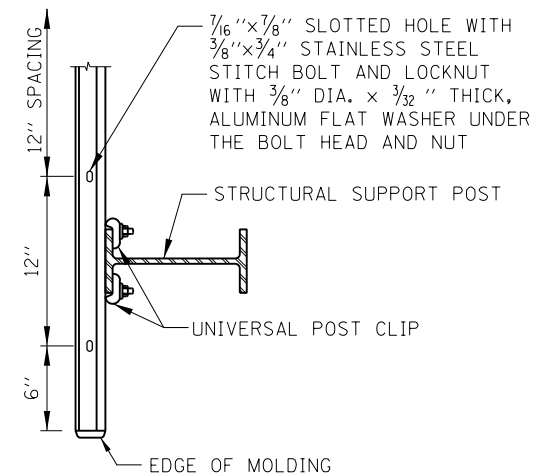

SECTION C-C

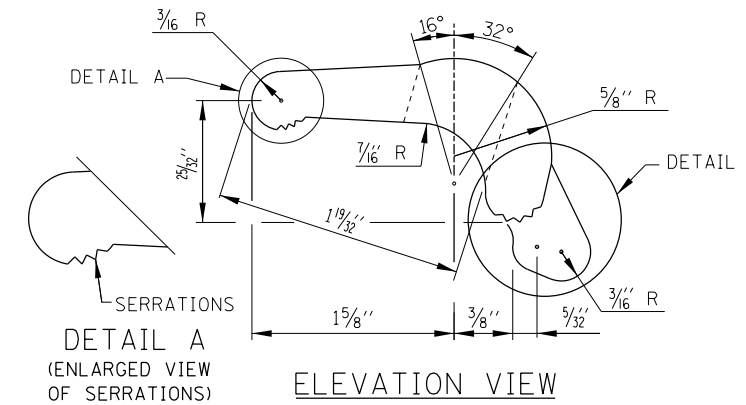

ELEVATION VIEW

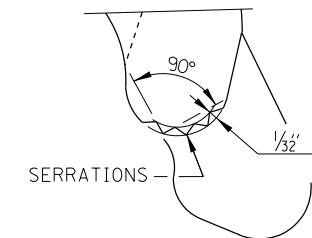

DETAIL B
(ENLARGED DETAIL
OF SERRATIONS)

ALUMINUM CLIP DETAIL

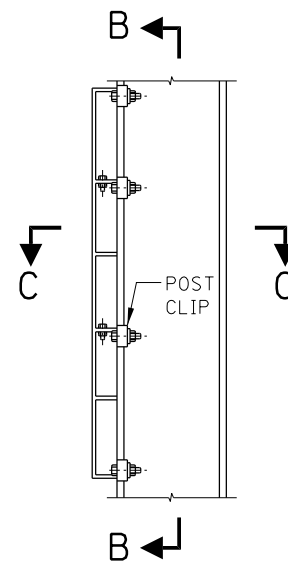

SECTION A-A

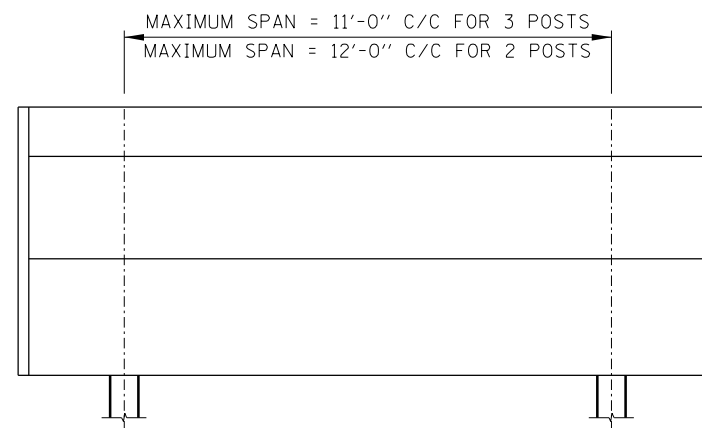

FACE OF SIGN PANEL

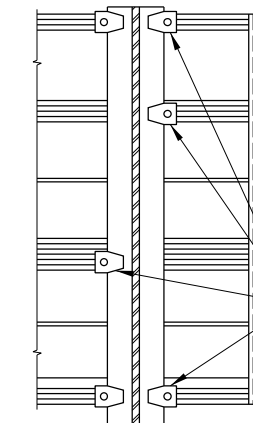

SECTION B-B

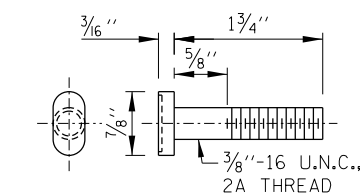

POST CLIP BOLT
STAINLESS STEEL

PROVIDE TWO (2) POST CLIPS AT TOP AND BOTTOM. ALTERNATE INTERIOR POST CLIPS ON SIGNS UNDER 24 FEET LONG AND OVER HEAD MOUNTED SIGNS. DO NOT ALTERNATE INTERIOR CLIPS ON OTHER SIGNS. A 3/8" DIA. x 3/32" THICK, ALUMINUM FLAT WASHER SHALL BE USED UNDER EACH NUT TO PREVENT GOUGING OF THE CLIP.



DATE	REVISIONS
1-1-2009	MODIFIED TYPE B SIGN PANEL DIM.
	MODIFIED POST CLIP DETAIL
2-7-2012	REMOVED DETAIL FOR MOUNTING 2 PANEL SIGN
3-11-2015	ADDED WASHERS TO CONNECTION DETAILS

MISCELLANEOUS DETAILS
AND ALUMINUM SIGN PANELS

STANDARD F10-03

APPROVED...
Paul Kovacs
CHIEF ENGINEER
DATE 2-7-2012...

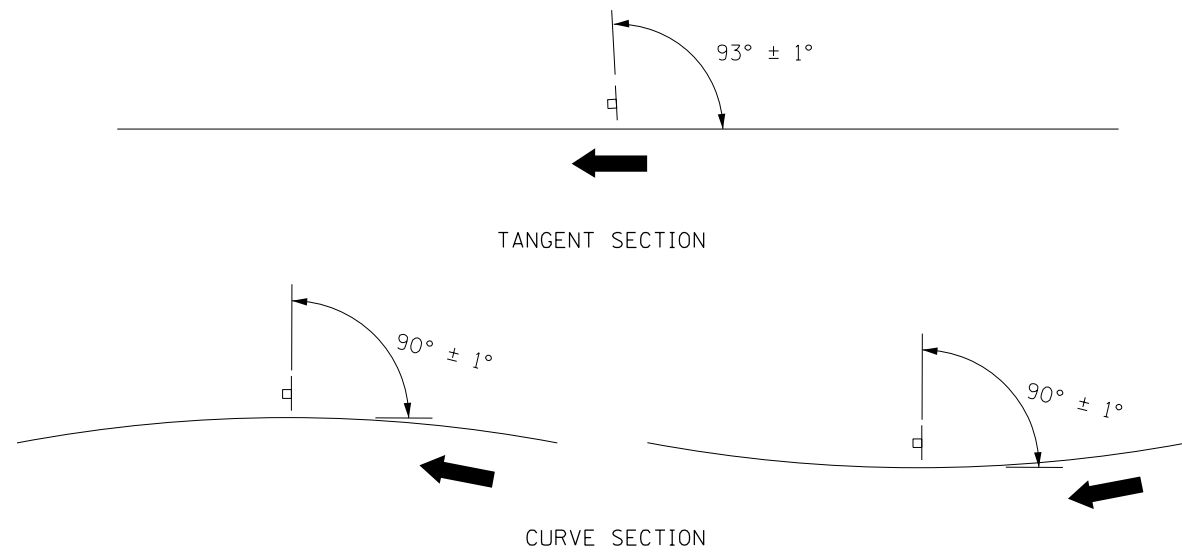

GROUND MOUNT SIGN POSITIONING

NOT TO SCALE

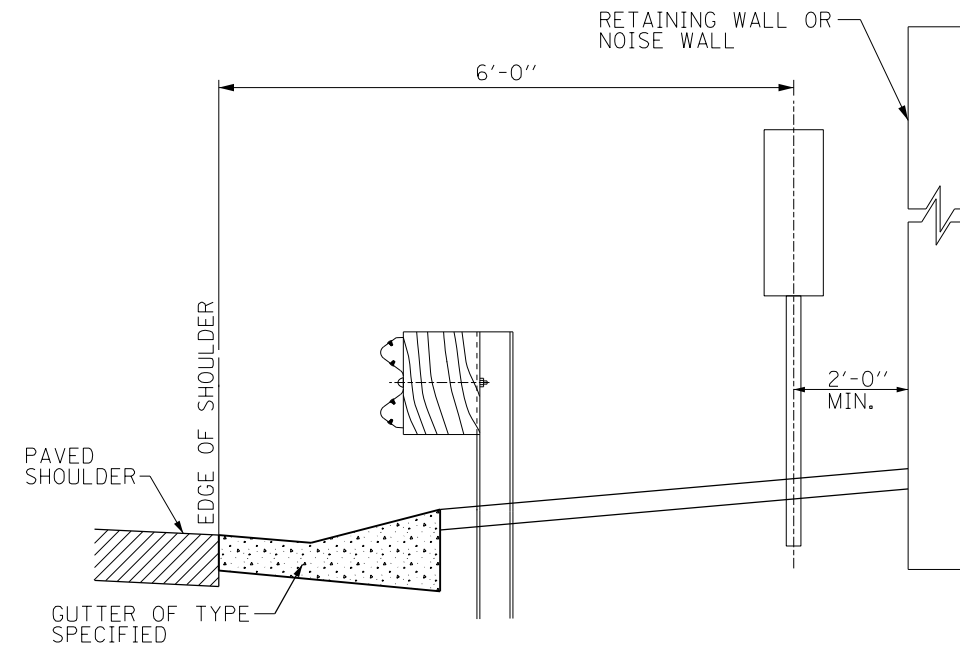

SECTION WITH GUTTER

NOT TO SCALE

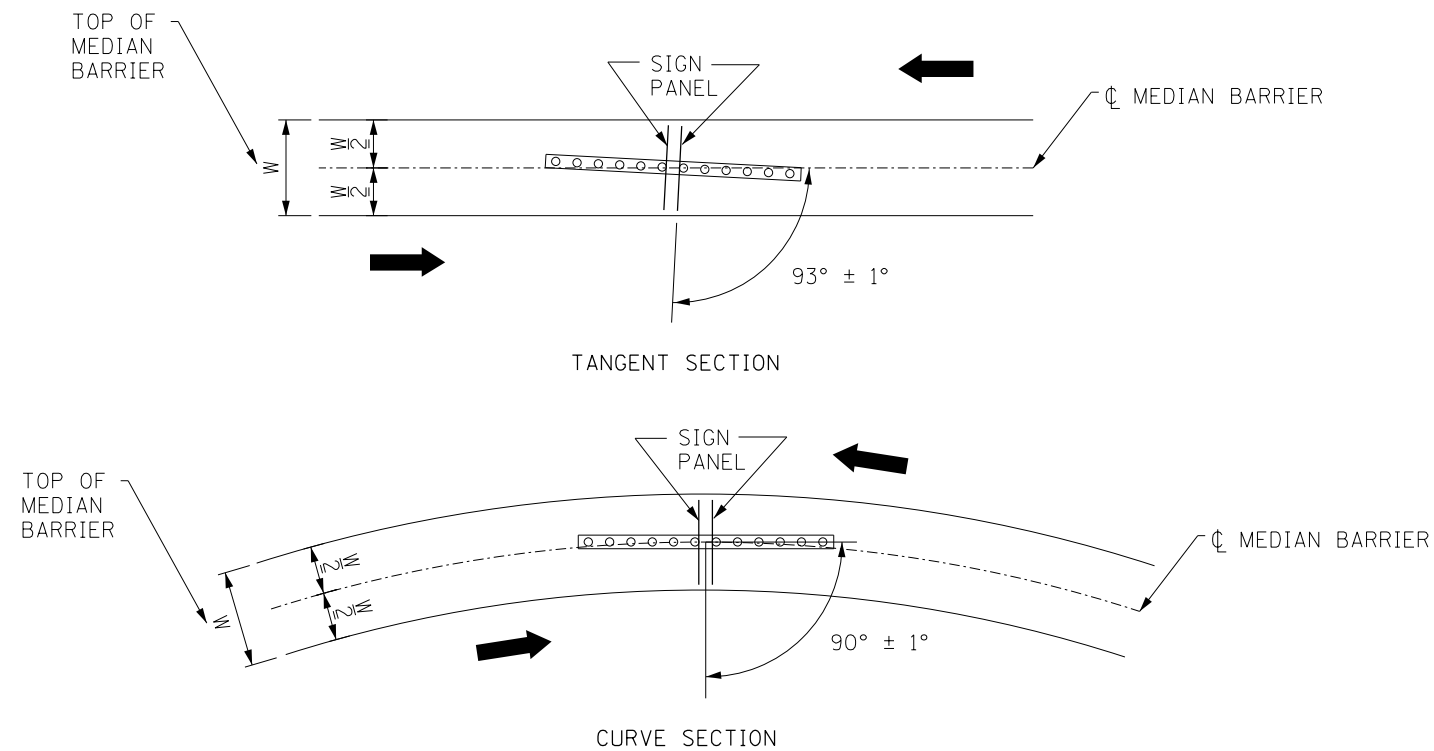

MEDIAN BARRIER SIGN POSITIONING

NOT TO SCALE

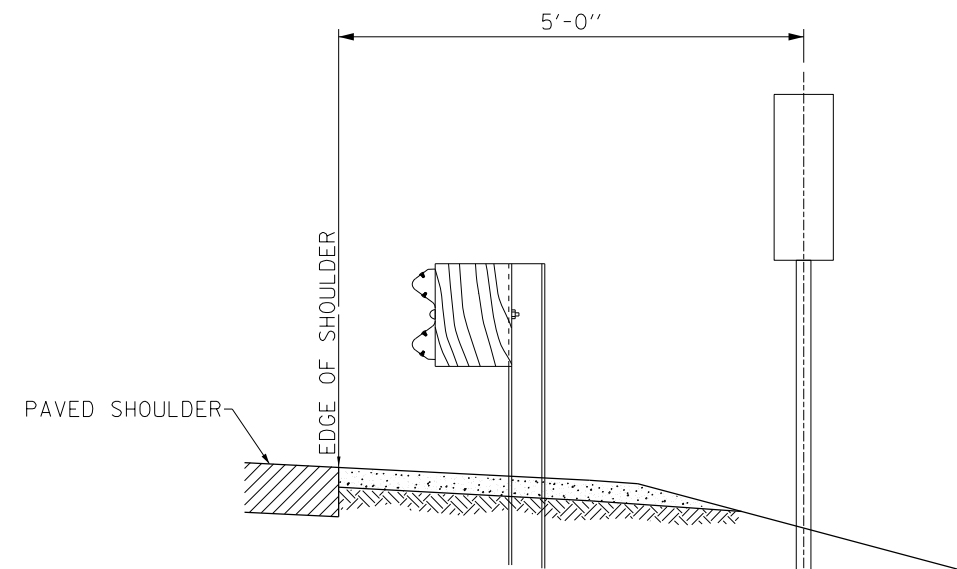

SECTION WITHOUT GUTTER

NOT TO SCALE

← DIRECTION OF TRAFFIC



MILEPOST MARKER

STANDARD F11-04

DATE	REVISIONS
5-8-2009	POSITIONING DETAILS
8-1-2009	REVISED BARRIER WALL MOUNT
3-1-2013	REMOVED MILE POST SIGNS
3-31-2016	REVISED BOLT NOTE

APPROVED *Paul Kovacs* CHIEF ENGINEER DATE 4-6-2009

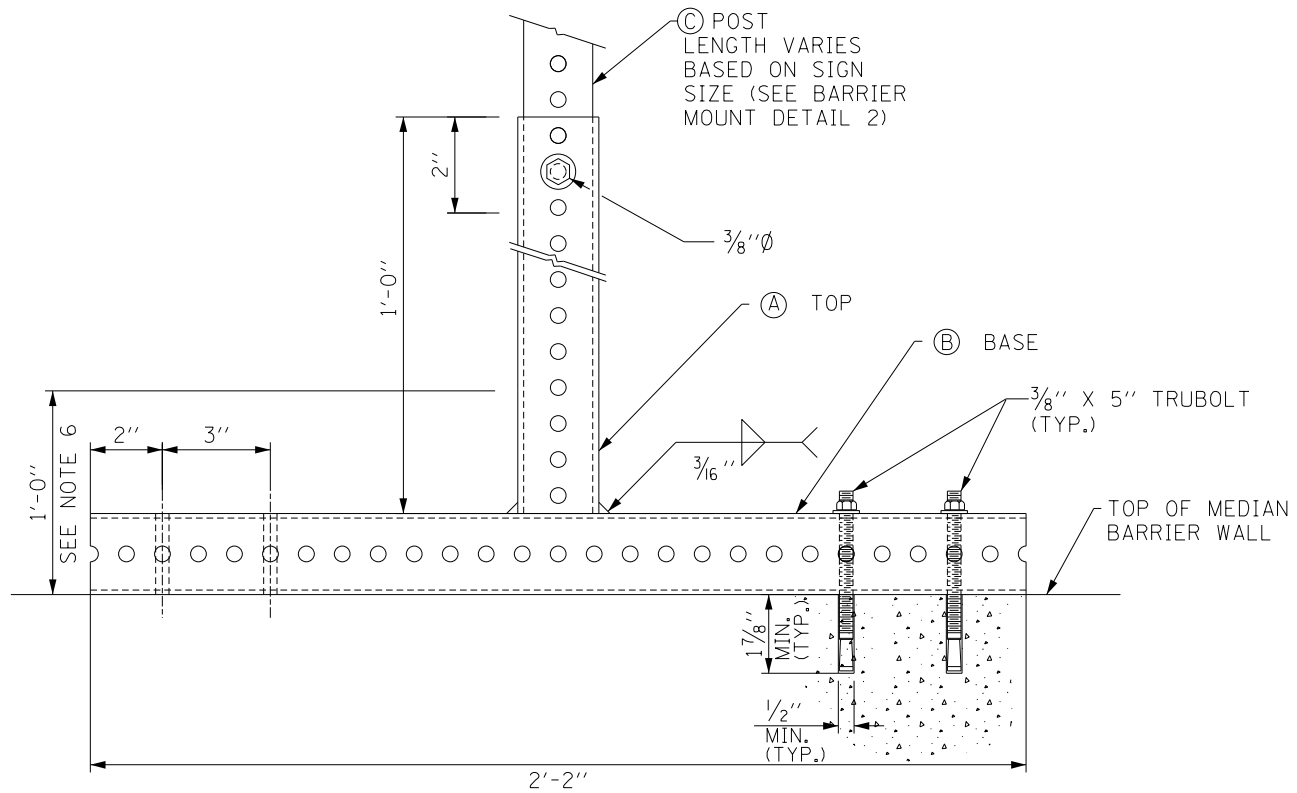

BARRIER WALL MOUNT DETAIL

NOT TO SCALE

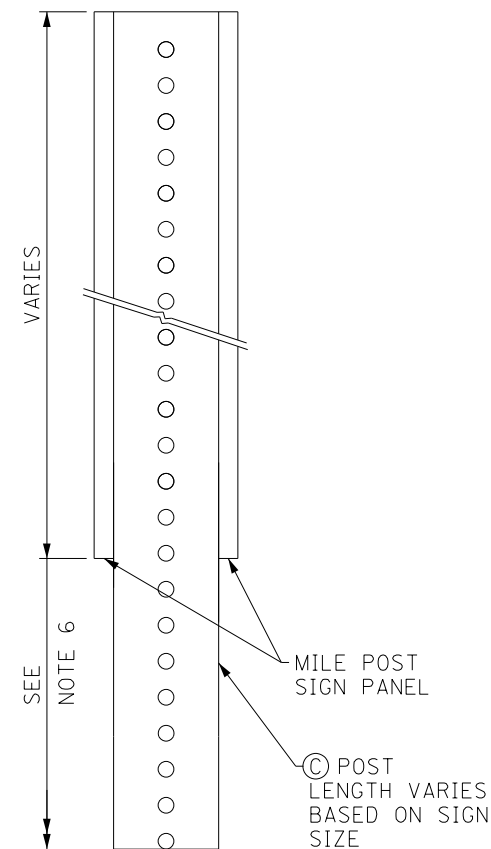

BARRIER WALL MOUNT DETAIL 2

NOT TO SCALE

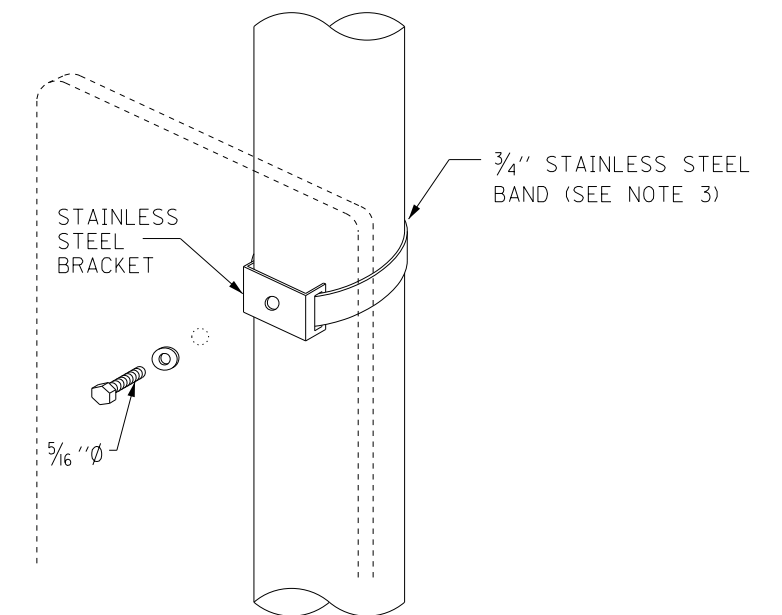

LIGHT POLE/SIGN STRUCTURE MOUNT DETAIL

NOT TO SCALE

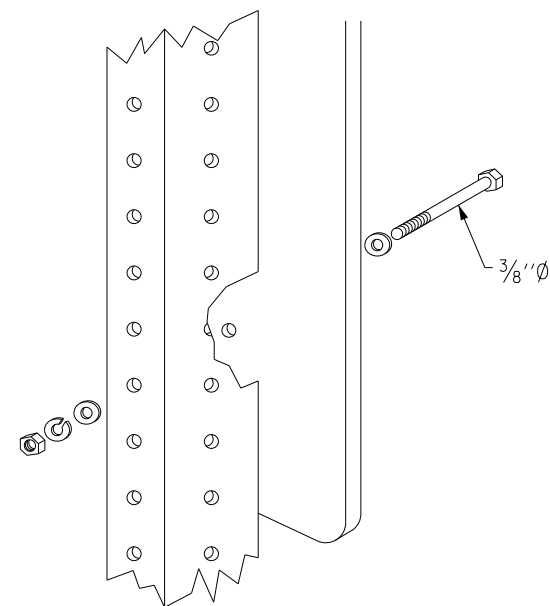

TELESCOPING STEEL POSTS

NOT TO SCALE

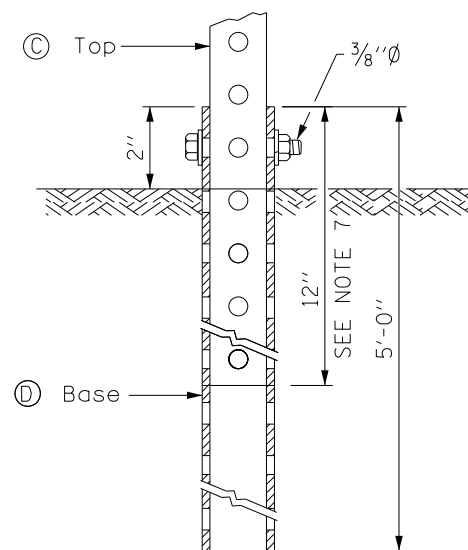

GROUND MOUNT DETAIL

NOT TO SCALE

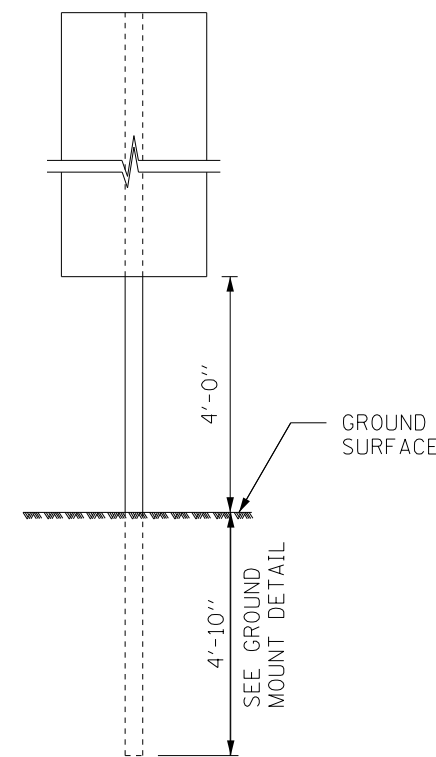

ONE POST INSTALLATION

NOT TO SCALE

GENERAL NOTES:

1. ALL ANCHOR BOLTS FOR MEDIAN BARRIER MOUNT DETAIL SHALL BE 3/8" DIA. RED HEAD "TRUBOLT" OR APPROVED EQUAL.
2. ALL DIMENSIONS ARE IN INCHES UNLESS SHOWN OTHERWISE.
3. FOLLOWING ARE THE STEPS FOR FASTENING THE MILEPOST MARKER SIGN PANEL. ALL MOUNTING DETAILS SHOWN ON THIS SHEET APPLY:
 - a. CENTER ALL FASTENERS ON THE SIGN PANEL.
 - b. START AND FINISH THE FASTENER SPACING USING A MINIMUM OF 3" TO A MAXIMUM OF 6" FROM THE TOP AND BOTTOM EDGE OF THE SIGN PANEL.
 - c. THE DISTANCE BETWEEN SUCCESSIVE FASTENERS SHALL NOT EXCEED 2'-0".
4. CENTER THE 5/16" DIA. BOLT IN THE MIDDLE OF THE SIGN.
5. USE THE SAME ATTACHMENT FOR BACK TO BACK MILEPOST MARKER SIGN.
6. DISTANCE FROM THE GROUND TO THE BOTTOM OF THE MILEPOST MARKER SIGN SHALL HAVE A MINIMUM OF 4'-0" REGARDLESS OF BARRIER TYPE.
7. THE TOP SECTION SHALL BE TELESCOPED INTO THE BASE SECTION 12 INCHES AND FASTENED TOGETHER.
8. FOR ATTACHMENT TO BRIDGE PARAPET USE BARRIER MOUNT WALL DETAIL. ONLY ONE PANEL REQUIRED WHEN ATTACHED TO PARAPET ALONG OUTSIDE SHOULDER.

(A)	2 1/4" x 2 1/4" x 1'-0" (12 GA.)
(B)	2 1/4" x 2 1/4" x 2'-2" (12 GA.)
(C)	2" x 2" x VARIES (12 GA.)
(D)	2 1/2" x 2 1/2" x 5'-0" (12 GA.)



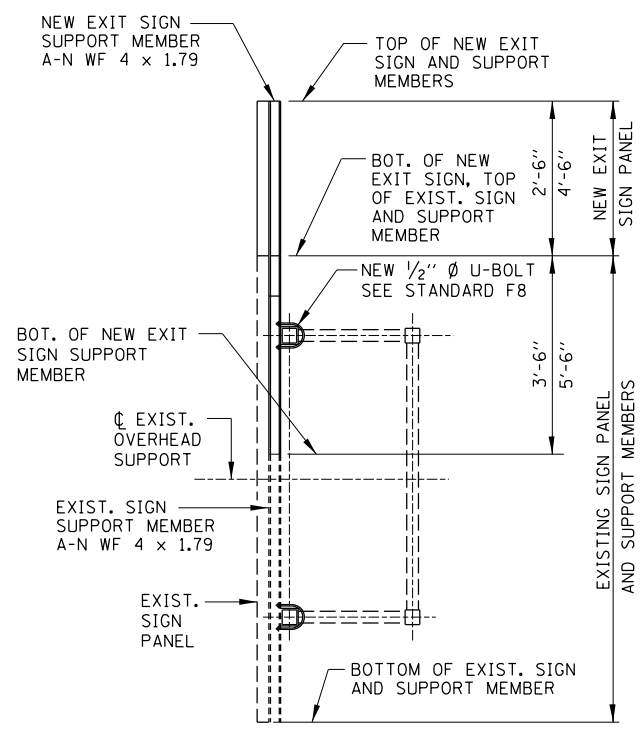
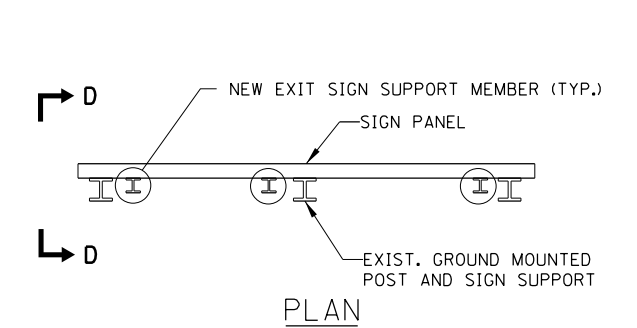
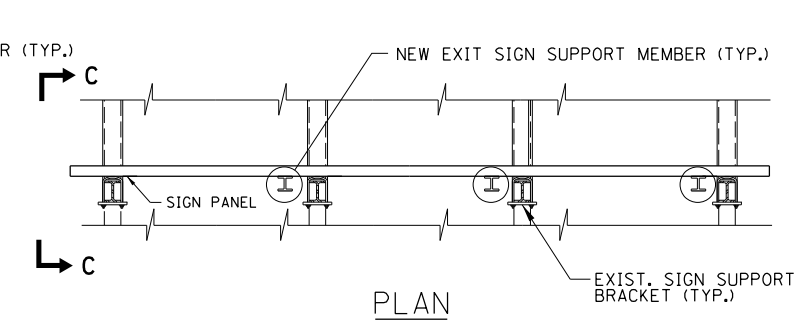
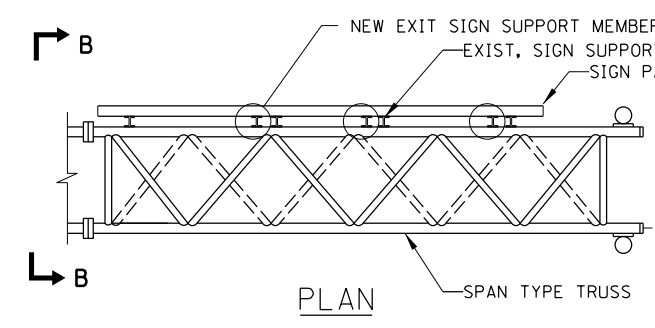
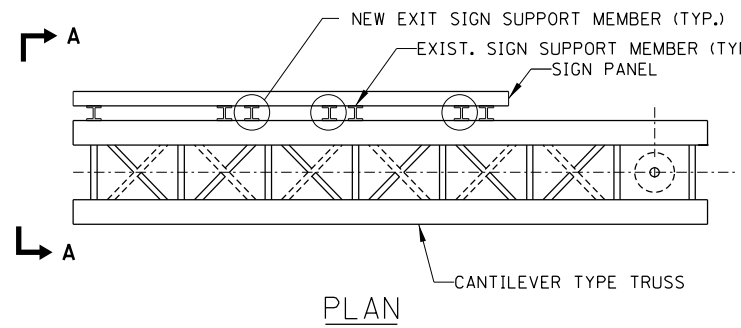

SECTION A-A

OVERHEAD CANTILEVER TYPE SIGN SUPPORT

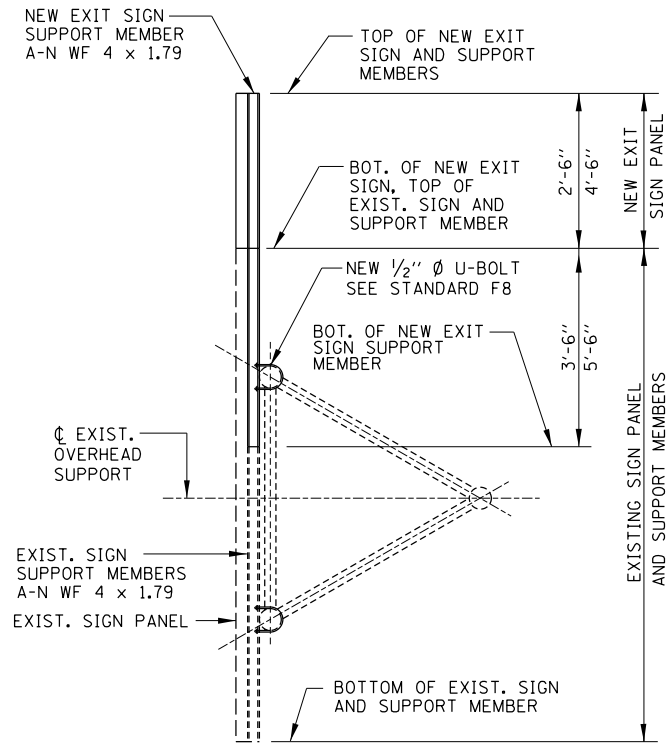

SECTION B-B

OVERHEAD SPAN TYPE SIGN SUPPORT

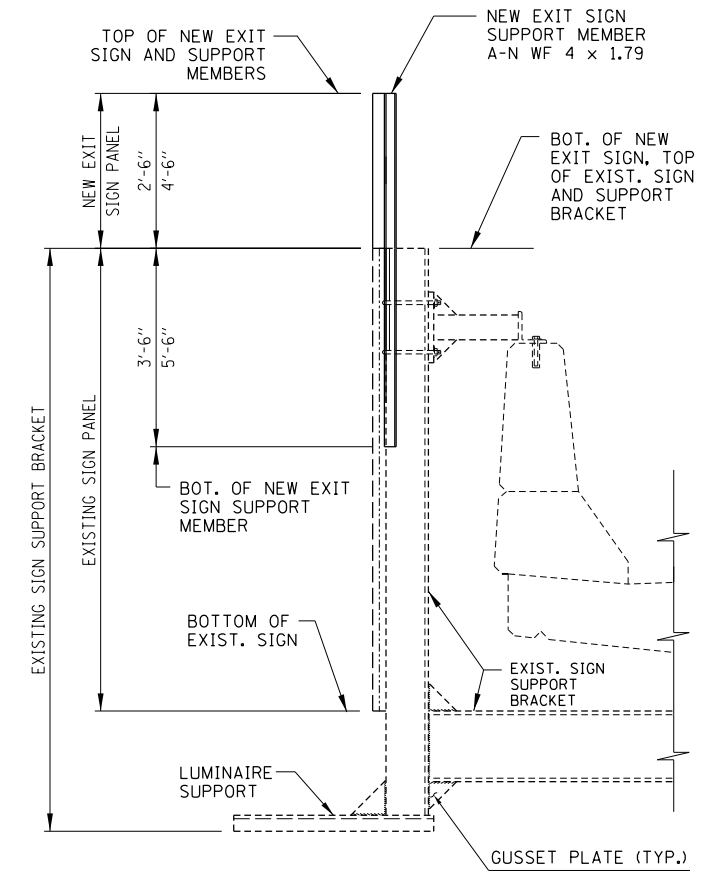

SECTION C-C

BRIDGE MOUNTED SIGN SUPPORT

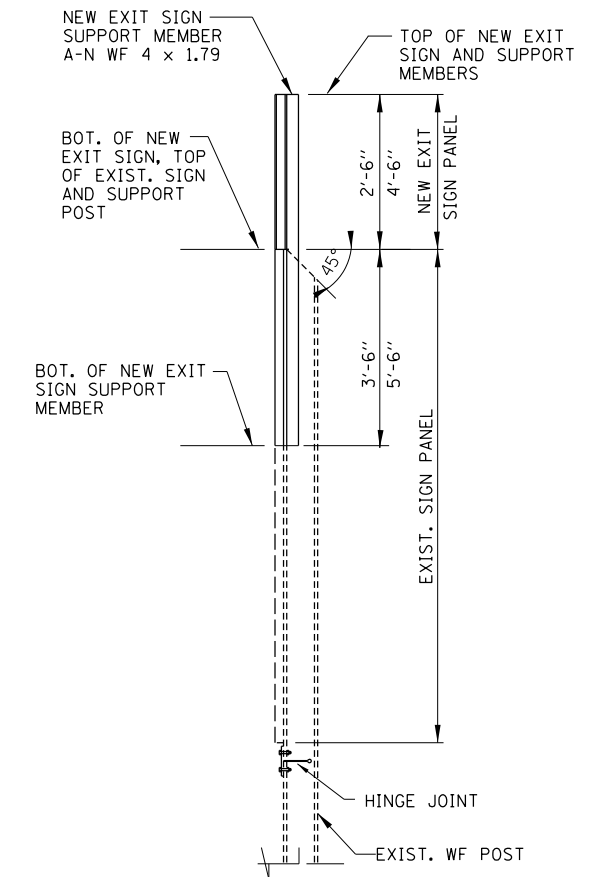

SECTION D-D

GROUND MOUNTED SIGN SUPPORT

DETAILS FOR RETROFITTING NEW EXIT SIGN

NOTES:

1. ALL MATERIAL IS ALUMINUM IN ACCORDANCE WITH SECTION 733 OF THE LATEST STANDARD SPECIFICATIONS. (UNLESS OTHERWISE NOTED).
2. EXISTING TRUSS AND SUPPORT MEMBERS SHALL BE CHECKED FOR STRUCTURAL ADEQUACY TO SUPPORT THE ADDITIONAL SIGN PANEL AREA.
3. NEW SIGN SUPPORT MEMBERS SHALL BE SPACED WITH EXISTING SIGN SUPPORTS. SPACING SHALL NOT EXCEED 6'-0".

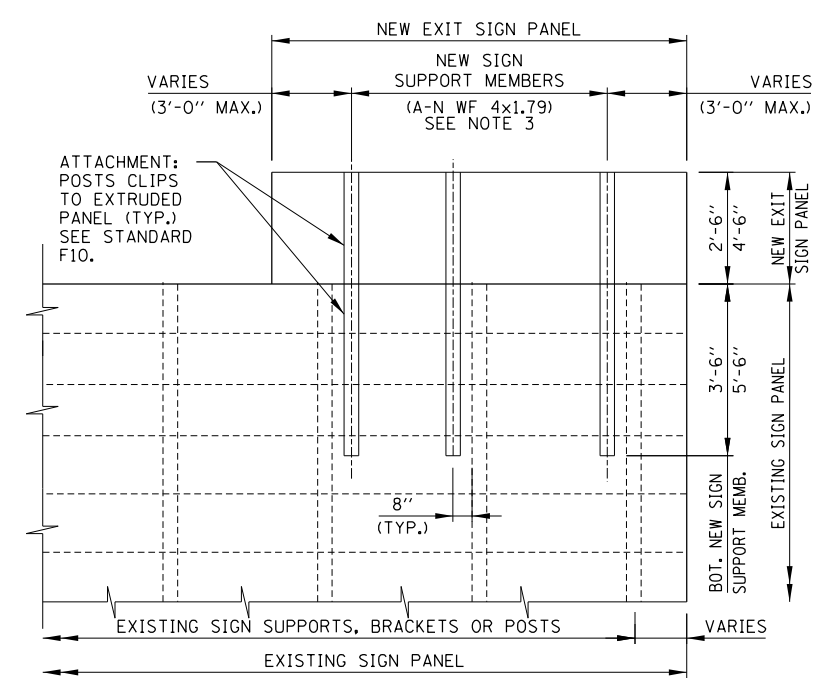

PARTIAL REAR ELEVATION OF SIGN PANELS AND SUPPORT MEMBERS

APPROVED: *Paul Kovacs* CHIEF ENGINEER DATE 3-1-2013

DATE	REVISIONS
3-11-2015	REVISED SUPPORT SPACING.



MOUNTING DETAILS FOR RETROFITTING NEW EXIT SIGN PANELS
STANDARD F12-01

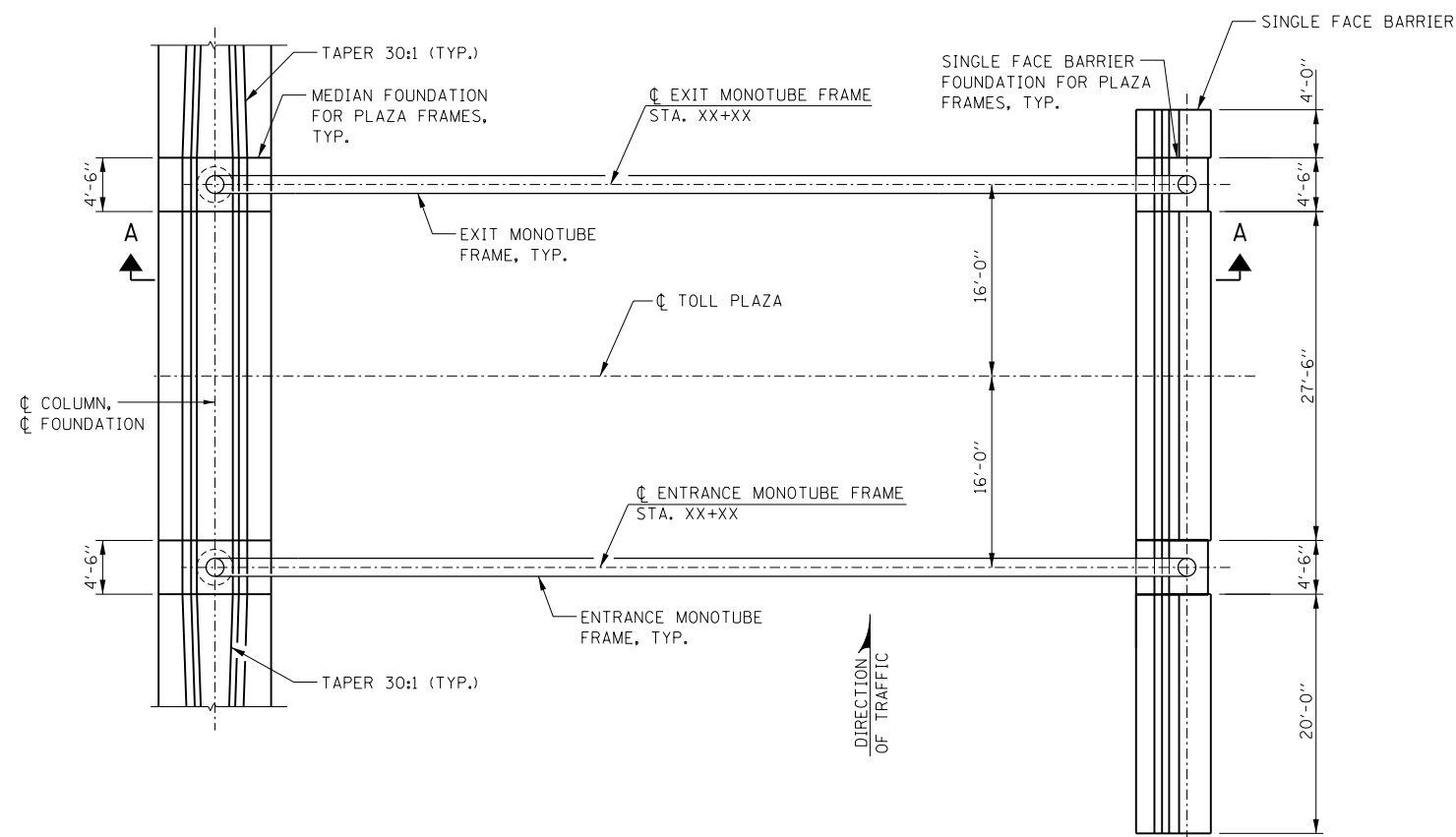

TOLL PLAZA PLAN

NOTES:

1. SEE PLANS FOR SIGN SIZE AND LOCATION.
2. MAXIMUM PLAZA SIGN AREA IS 108 SQ. FT.
MAXIMUM PLAZA SIGN LENGTH IS 36 FT.

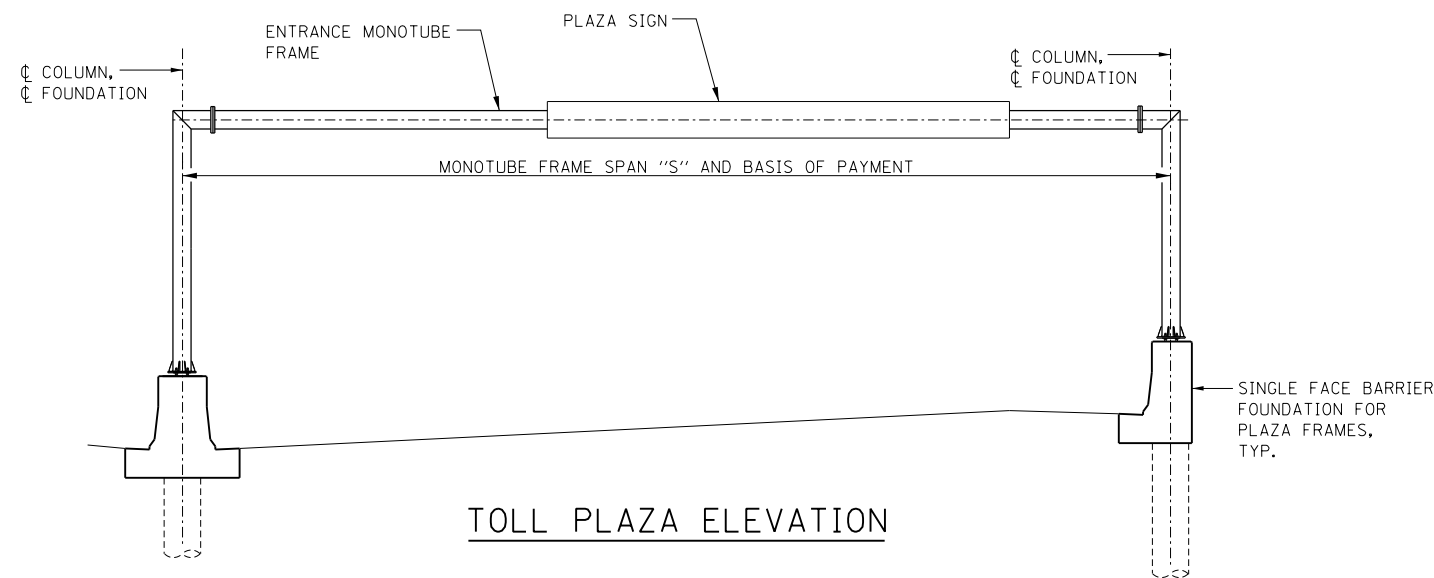

TOLL PLAZA ELEVATION

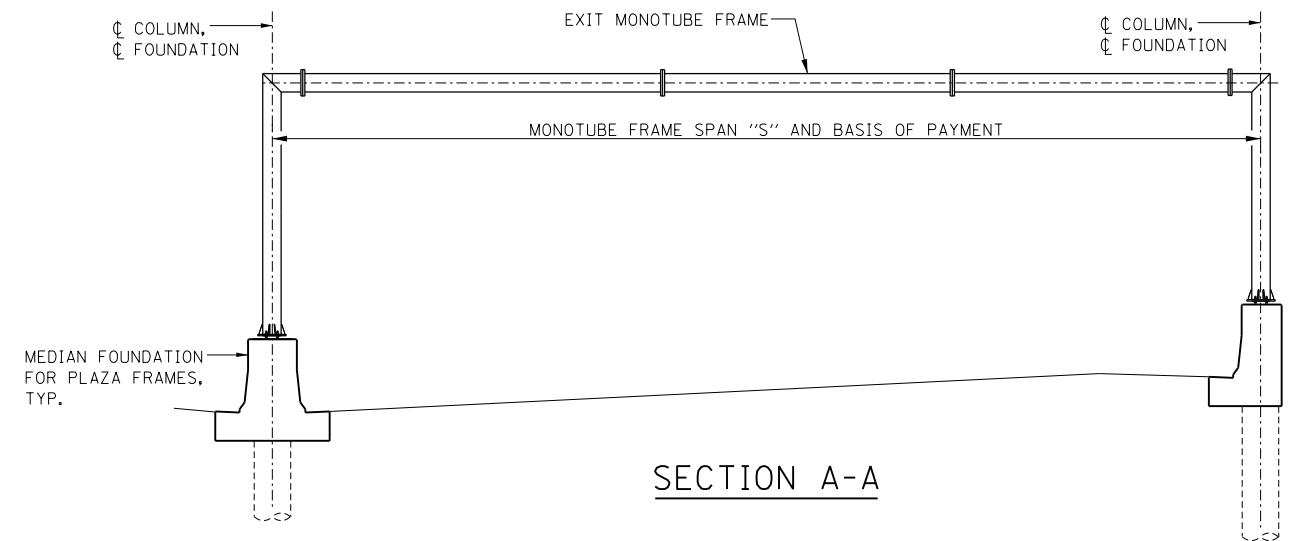

SECTION A-A



DATE	REVISIONS	
7-01-2014	ADDED GROUNDING DETAILS.	OVERHEAD SIGN STRUCTURE MONOTUBE TYPE (STEEL) MAINLINE STRUCTURE DETAILS
3-11-2015	ADDED MEDIAN AND NOTES.	
3-31-2016	REVISED FOUNDATION NOTE.	
		STANDARD F13-02

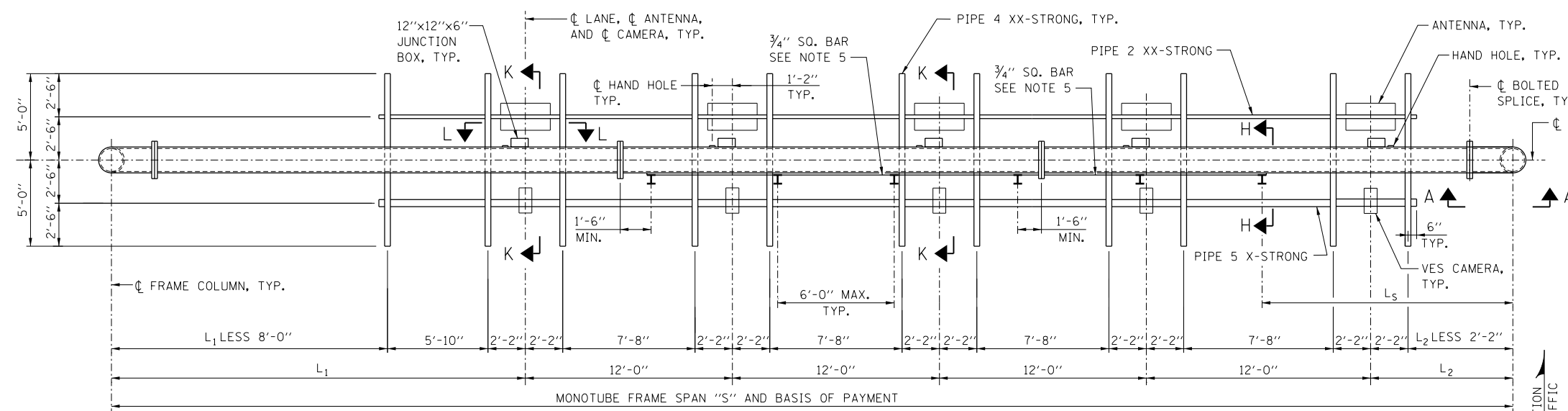

 APPROVED..... CHIEF ENGINEER..... DATE 3-31-2014

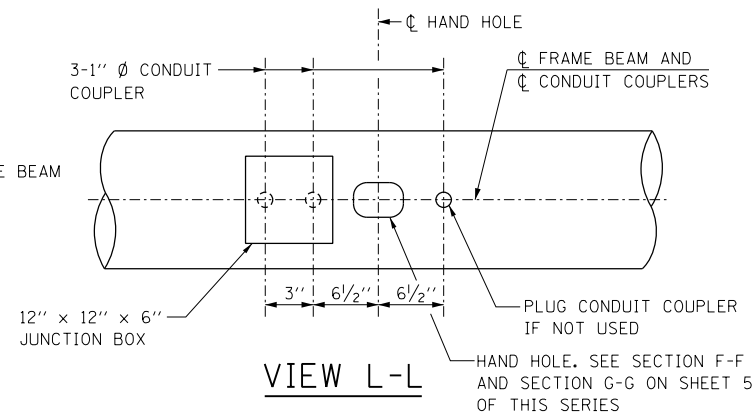

ENTRANCE MONOTUBE PLAN

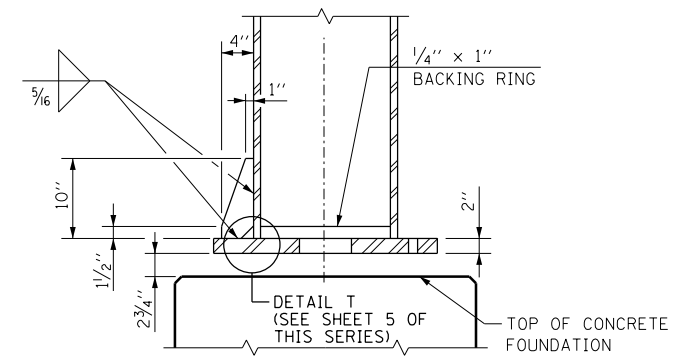

VIEW L-L



SECTION S-S

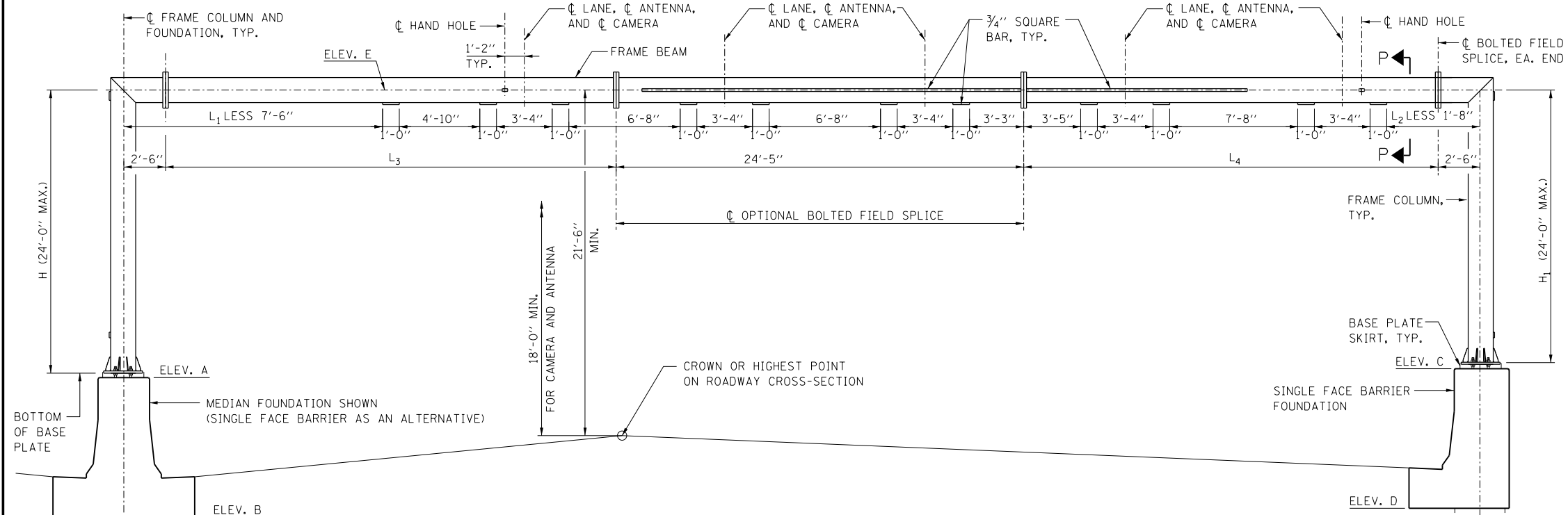

ENTRANCE MONOTUBE ELEVATION

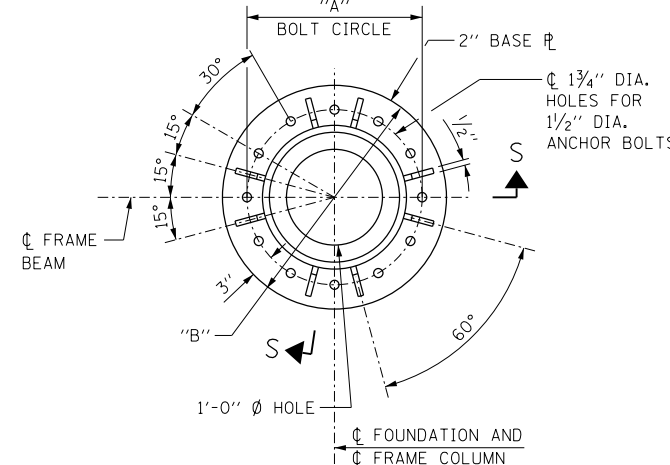

BASE PLATE PLAN MONOTUBE FRAMES

NOTES:

1. FOUNDATIONS FOR PLAZA FRAMES ARE SHOWN ON SHEETS 6 AND 7 OF THIS SERIES.
2. FOR SECTIONS A-A, H-H, K-K, BASE PLATE SKIRT AND HAND HOLE DETAILS, SEE SHEET 5 OF THIS SERIES.
3. FOR SECTION P-P SEE SHEET 4 OF THIS SERIES.
4. PROVIDE CAMBER AT MIDSPAN OF STRUCTURE.
5. DISCONTINUE 3/4" SQUARE BAR TO ALLOW 1/2" Ø U-BOLT INSTALLATION.
6. WORK THIS SHEET WITH, OVERHEAD SIGN STRUCTURES ENTRANCE MONOTUBE TYPE (STEEL) MAINLINE SUMMARY AND TOTAL BILL OF MATERIAL SHEET.

MONOTUBE FRAME TABLE

TYPE	SPAN "S"	FRAME COLUMN	FRAME BEAM	CAMBER	"A"	"B"
I	≤ 70'	HSS 16x0.500	HSS 16x0.500	2 3/4"	1'-8"	2'-2"
II	71'-80'	HSS 18x0.500	HSS 18x0.500	4"	1'-10"	2'-4"
III	81'-90'	HSS 18x0.500	HSS 18x0.500	4 1/2"	1'-10"	2'-4"

APPROVED: *Paul Kovacs* CHIEF ENGINEER DATE 3-31-2014



OVERHEAD SIGN STRUCTURE MONOTUBE TYPE (STEEL) MAINLINE STRUCTURE DETAILS

STANDARD F13-02

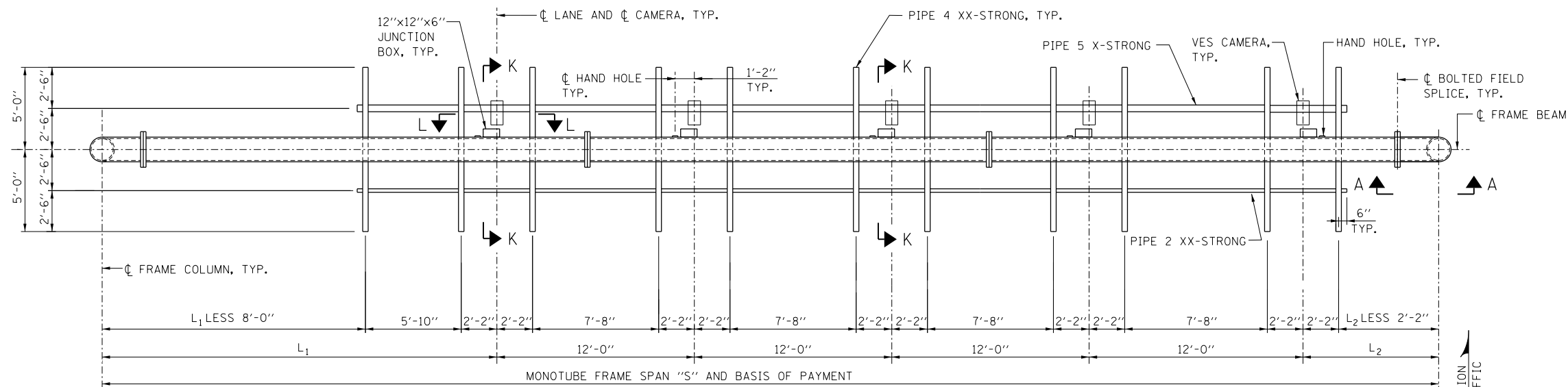

EXIT MONOTUBE PLAN

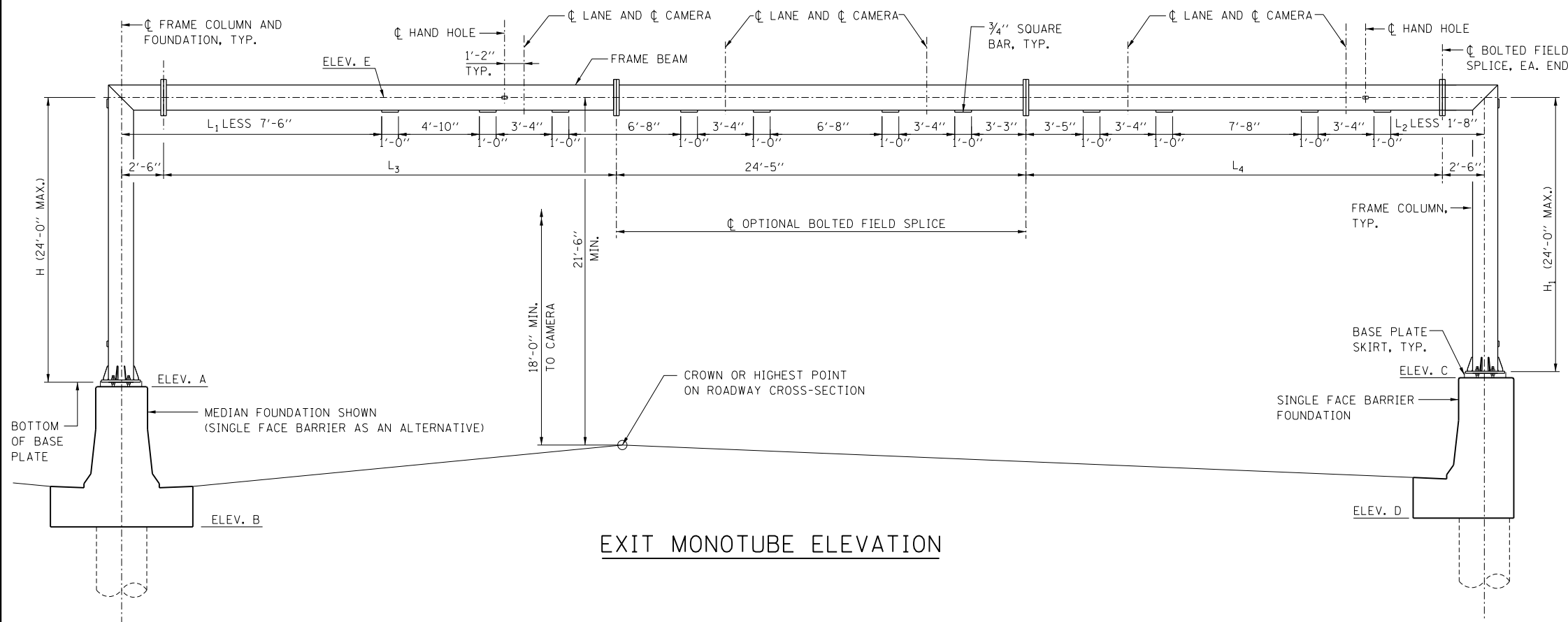

EXIT MONOTUBE ELEVATION

NOTES:

1. SEE SHEET 2 OF THIS SERIES FOR MONOTUBE FRAME TABLE, VIEW L-L, BASE PLATE DETAIL, AND ADDITIONAL NOTES.
2. WORK THIS SHEET WITH, OVERHEAD SIGN STRUCTURES EXIT MONOTUBE TYPE (STEEL) SUMMARY AND TOTAL BILL OF MATERIAL SHEET.



GENERAL NOTES:

1. SEE THE ILLINOIS TOLLWAY STRUCTURE DESIGN MANUAL FOR MINIMUM VERTICAL CLEARANCE.
2. AFTER ADJUSTMENTS TO LEVEL FRAME BEAM AND ENSURE ADEQUATE VERTICAL CLEARANCE, TIGHTEN ALL TOP AND LEVELING NUTS AGAINST THE BASE PLATE WITH A MINIMUM TORQUE OF 200 LB.-FT. THEN PLACE STAINLESS STEEL MESH AROUND THE PERIMETER OF THE BASE PLATE. SECURE TO BASE PLATE WITH STAINLESS STEEL BANDING.
3. REINFORCEMENT BARS DESIGNATED "E" SHALL BE EPOXY COATED.

STRUCTURAL STEEL:

1. MATERIAL FOR THE MONOTUBE FRAME SHALL CONFORM TO THE REQUIREMENT OF ASTM A500 GRADE B. OTHER STRUCTURAL STEEL SHAPES AND PLATES SHALL CONFORM TO THE REQUIREMENTS OF ASTM A36, UNLESS NOTED OTHERWISE.
2. PIPES SHALL CONFORM TO THE REQUIREMENTS OF ASTM A53 GRADE B.
3. ANCHOR BOLTS SHALL CONFORM TO THE REQUIREMENTS OF ASTM F1554 (AASHTO M314) GRADE 55, WITH A MINIMUM TENSILE STRENGTH OF 75,000 PSI. THEY SHALL BE GALVANIZED IN ACCORDANCE WITH ASTM A153 (AASHTO M232). SEE SHEET 6 OF THIS SERIES FOR GALVANIZED LENGTH.
4. U-BOLTS SHALL BE STAINLESS STEEL AND SHALL CONFORM TO ASTM 193, CLASS I, GRADE B8 (AISI TYPE 304). WASHERS FOR U-BOLTS SHALL CONFORM TO ASTM A240, TYPE 302. NUTS FOR U-BOLTS SHALL CONFORM TO ASTM A194 (AASHTO M292), GRADE 8F (AISI TYPE 303).
5. BOLTS (EXCLUDING ANCHOR BOLTS AND U-BOLTS) SHALL BE HIGH STRENGTH AND SHALL CONFORM TO THE REQUIREMENTS OF ASTM A325 (AASHTO M164). THEY SHALL BE GALVANIZED IN ACCORDANCE WITH ASTM A153 (AASHTO M232).
6. NUTS SHALL CONFORM TO ASTM A563 GRADE DH AND GALVANIZED ACCORDING TO ASTM A153 (AASHTO M232).
7. HARDENED STEEL WASHERS SHALL CONFORM TO ASTM F436 AND GALVANIZED ACCORDING TO ASTM A153 (AASHTO M232).
8. TUBES FOR MONOTUBE FRAME, PIPES, STRUCTURAL STEEL SHAPES AND PLATES SHALL BE GALVANIZED IN ACCORDANCE WITH ASTM A123 AFTER FABRICATION.
8. THE MONOTUBE FRAME BEAM, COLUMNS, BASE PLATE MATERIAL, AND SPLICES ARE CONSIDERED TENSION MEMBERS AND SHALL CONFORM TO THE IMPACT TESTING REQUIREMENT, ZONE 2.
10. WELDING SHALL BE PERFORMED BY CERTIFIED WELDERS USING E70-XX ELECTRODES, AND SHALL CONFORM TO AWS D1.1-08 "STRUCTURAL WELDING CODE - STEEL". ALL WELDS ON ARCHITECTURAL EXPOSED STEEL (AES) MEMBERS ARE TO BE GROUND SMOOTH AND FILLED.

DESIGN LOADING:

WIND LOAD CRITERIA
 BASIC WIND SPEED = 90 MPH
 G = 1.14
 I_r = 1.00 (50 YR. RECURRENCE INTERVAL)

EQUIPMENT LOADS:

CAMERA ASSEMBLY 8 LB.
 ANTENNA 20 LB.

DESIGN STRESSES FOR REINFORCED CONCRETE:

f'_c = COMPRESSIVE STRENGTH OF CONCRETE AT 14 DAYS (CLASS S1) = 3,500 P.S.I.
 f'_c = COMPRESSIVE STRENGTH OF CONCRETE AT 14 DAYS (CLASS DS) = 4,000 P.S.I.
 f_y = YIELD STRENGTH OF REINFORCEMENT BARS (GRADE 60) = 60,000 P.S.I.

FOUNDATION:

MINIMUM UNCONFINED COMPRESSIVE STRENGTH, Q_u FOR ALL LAYERS OF COHESIVE SOILS (CLAYS) SHALL BE 1.25 TON/SQ.FT. AT PLAZA FRAMES.

DESIGN SPECIFICATIONS:

1. STRUCTURE DESIGN MANUAL, DATED MARCH, 2014, WITH LATEST DESIGN BULLETINS.
2. AASHTO STANDARD SPECIFICATION FOR STRUCTURAL SUPPORTS FOR HIGHWAY SIGNS, LUMINAIRES AND TRAFFIC SIGNALS, 6TH EDITION.
3. AASHTO LRFD BRIDGE DESIGN SPECIFICATIONS, 6TH EDITION DATED FEBRUARY 2012.
4. ILLINOIS DEPARTMENT OF TRANSPORTATION BRIDGE MANUAL, JANUARY 2012

CONSTRUCTION SPECIFICATIONS:

1. ILLINOIS TOLLWAY SUPPLEMENTAL SPECIFICATIONS TO THE ILLINOIS DEPARTMENT OF TRANSPORTATION STANDARD SPECIFICATIONS FOR ROAD AND BRIDGE CONSTRUCTION, LATEST EDITION.
2. ILLINOIS DEPARTMENT OF TRANSPORTATION STANDARD SPECIFICATIONS FOR ROAD AND BRIDGE CONSTRUCTION, LATEST EDITION.

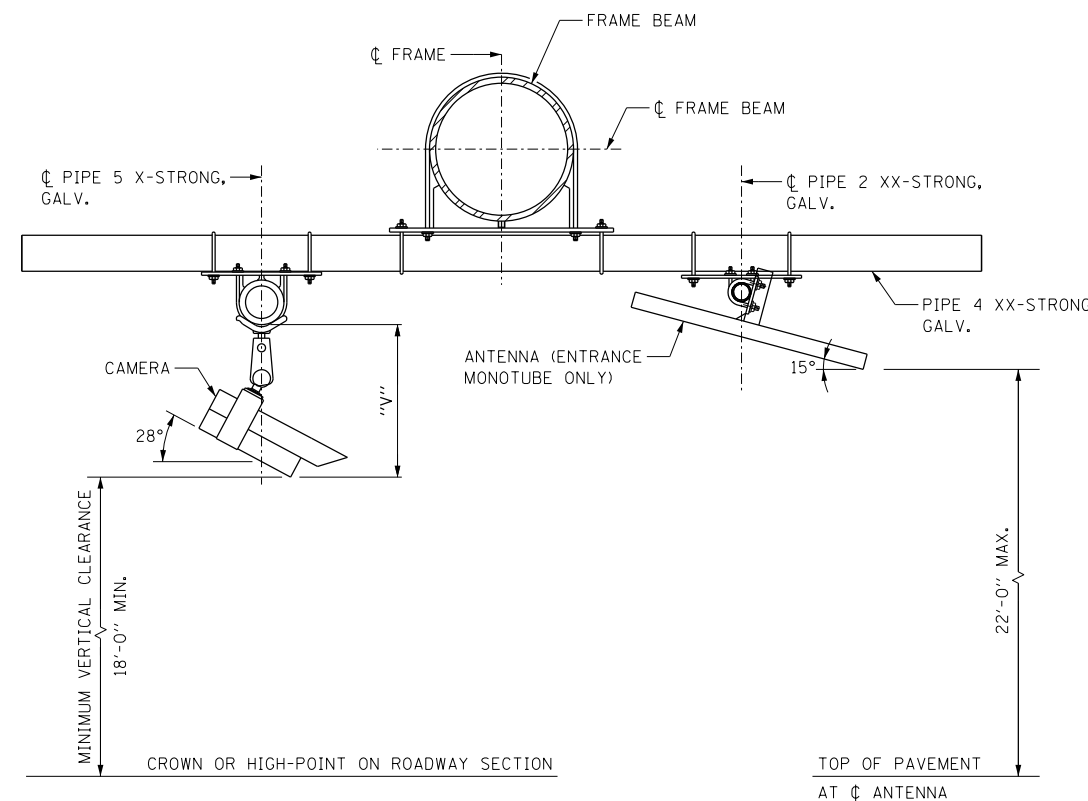

SECTION P-P

NOTE:

VERIFY DIMENSION "V" WITH CAMERA MANUFACTURER.

APPROVED: *Paul Kovacs* CHIEF ENGINEER DATE 3-31-2014



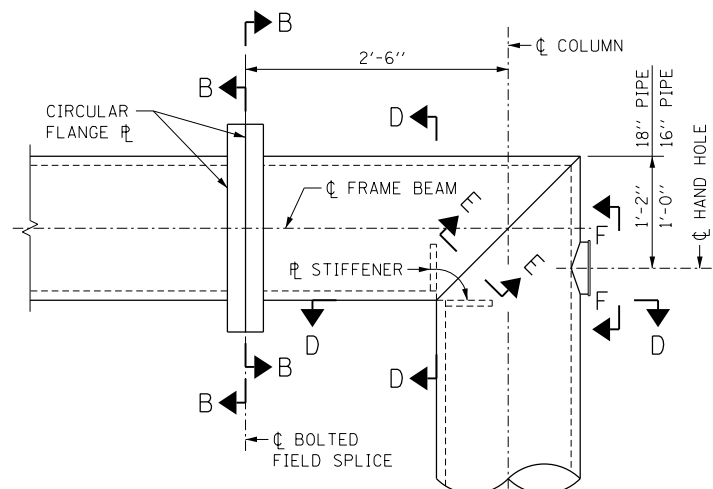

SECTION A-A

(SEE SHEET 1 OF THIS SERIES FOR LOCATION)

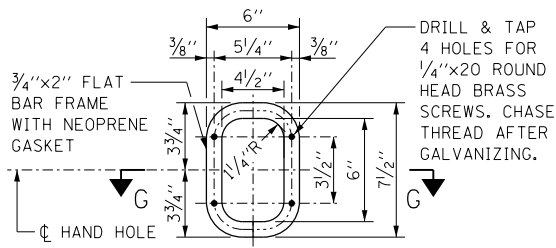

SECTION F-F

PROVIDE 6" x 7 1/2" #10 GA. COVER. ROUND CORNERS TO 2" RADIUS. PROVIDE FOUR 3/8" Ø HOLES.

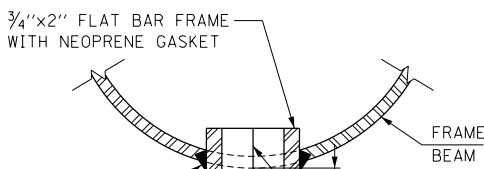

SECTION G-G

FRAME BEAM	"D"	"E"	"F"	"G"
HSS 16x0.500	10"	6"	1'-8"	2'-0 1/2"
HSS 18x0.500	11"	6"	1'-10"	2'-2 1/2"

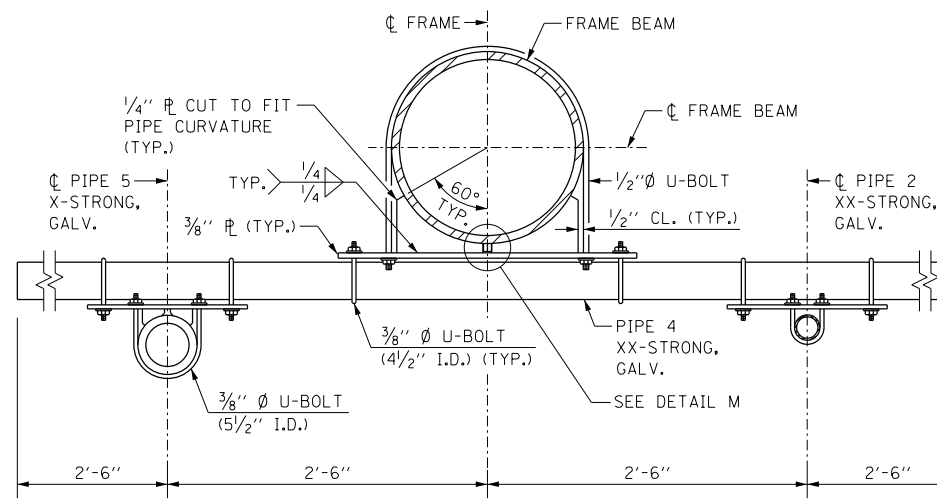

SECTION K-K

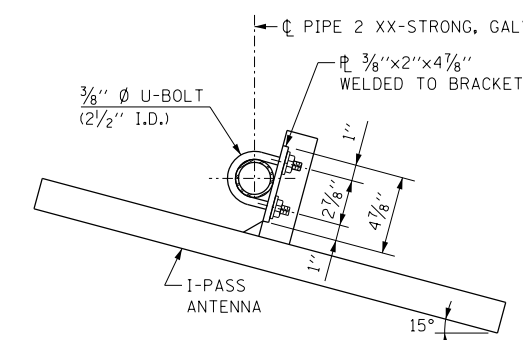

ANTENNA HANGER

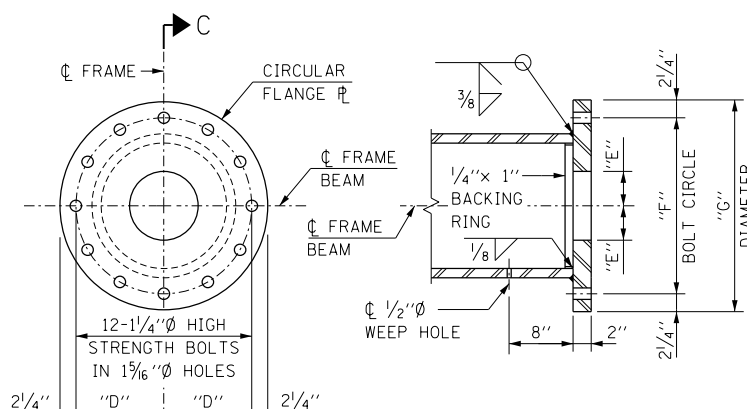

SECTION C-C

SECTION B-B

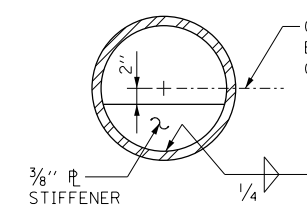

SECTION D-D

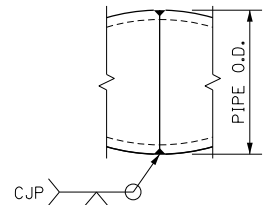

SECTION E-E

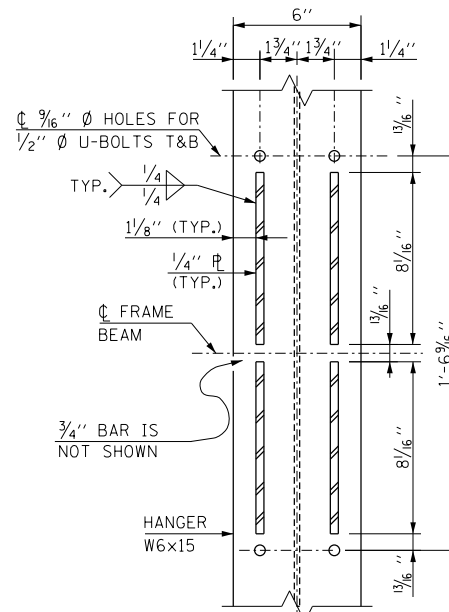

SECTION J-J

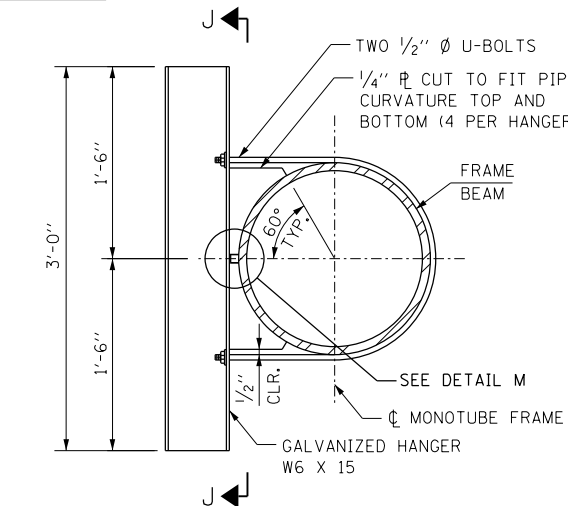

SECTION H-H (SIGN HANGER)

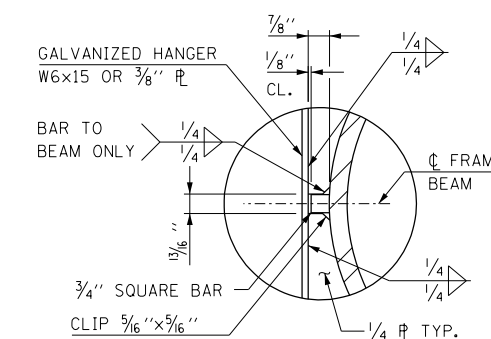

DETAIL M

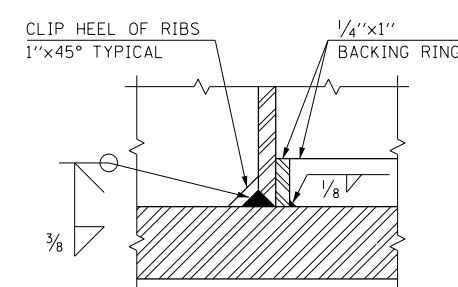

DETAIL T

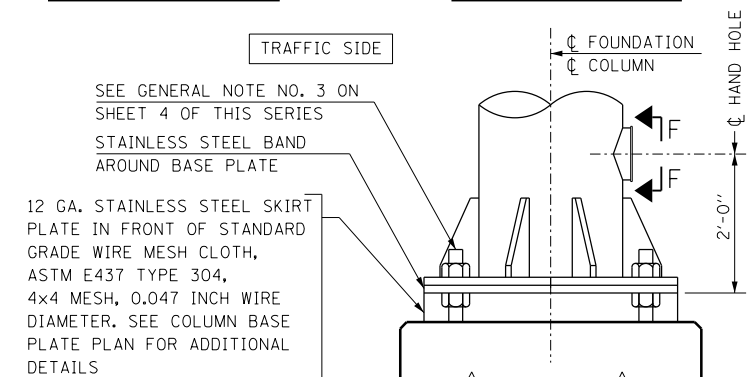

COLUMN BASE

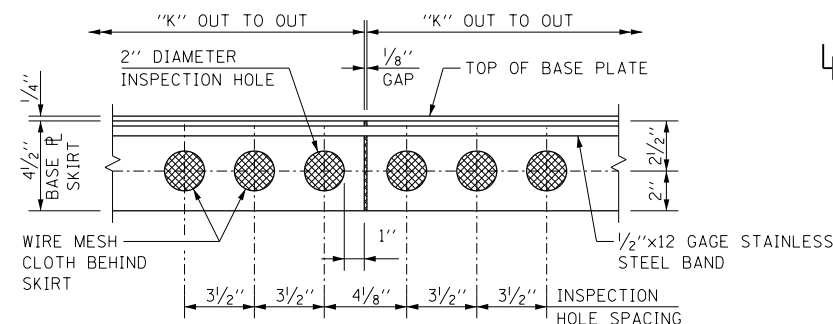

VIEW R-R (BASE PLATE SKIRT)

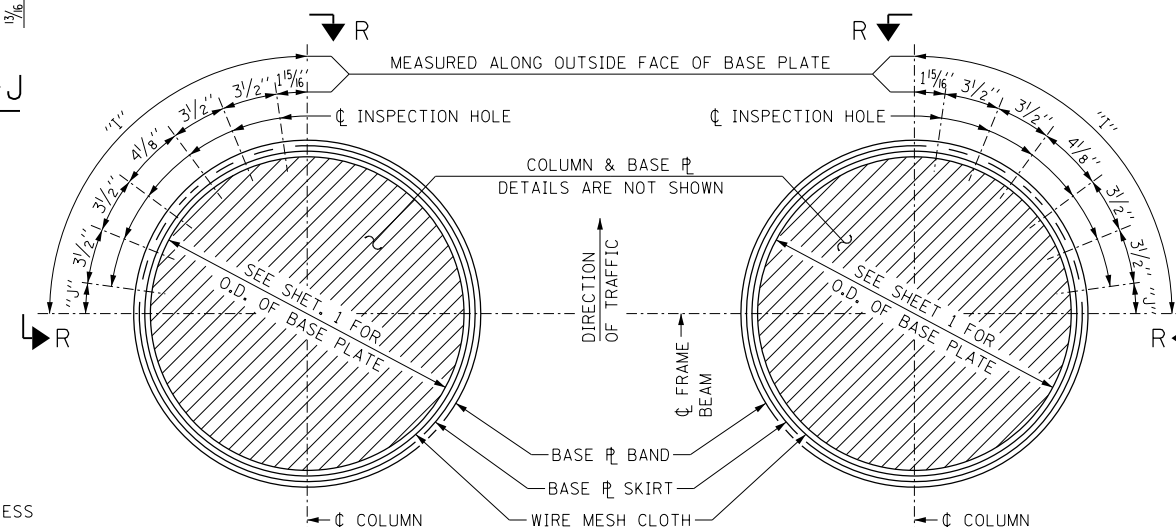

LEFT BASE PLATE

RIGHT BASE PLATE

COLUMN BASE PLATE PLAN

FRAME COLUMN	"I"	"J"	"K"
HSS 16x0.500	1'-8 7/16"	3/8"	6'-9 9/16"
HSS 18x0.500	1'-10"	1 1/8"	7'-3 7/8"

Illinois Tollway

OVERHEAD SIGN STRUCTURE
MONOTUBE TYPE (STEEL)
MAINLINE STRUCTURE DETAILS

STANDARD F13-02

APPROVED: *Paul Kovacs* CHIEF ENGINEER DATE 3-31-2014

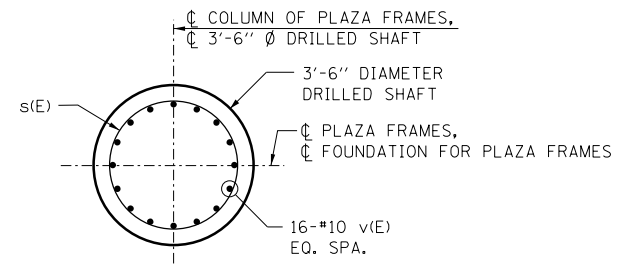
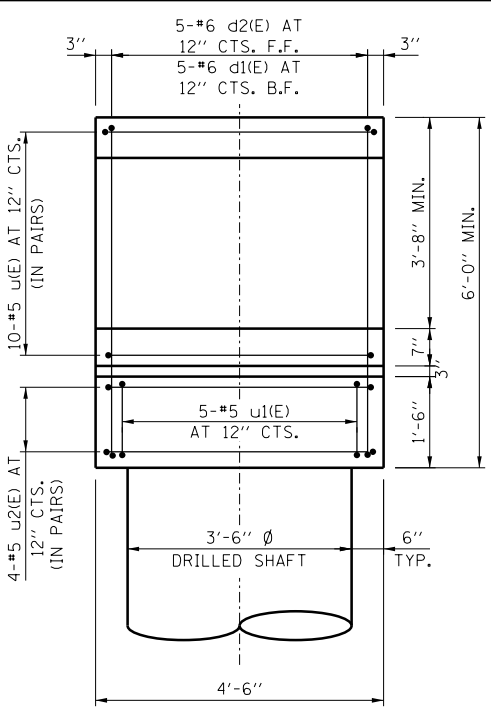
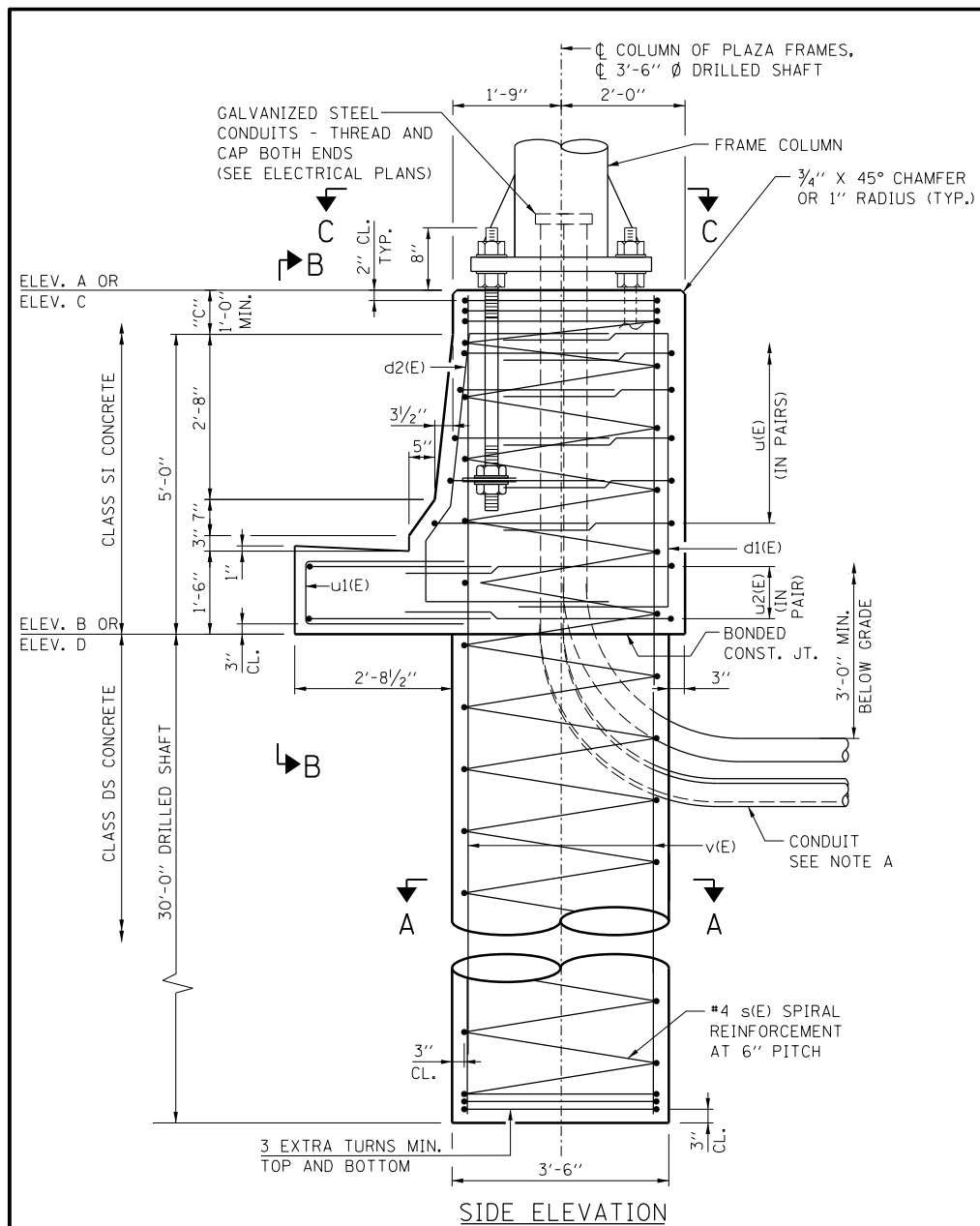

NOTE A:
COORDINATE CONDUIT SIZE, LOCATION AND QUANTITY WITH ELECTRICAL PLANS. CONDUITS SHALL BE PLACED TO MISS REINFORCEMENT. CUTTING OF REINFORCEMENT SHALL NOT BE ALLOWED.

FOUNDATIONS:
THE FOUNDATION DETAILS SHOWN ARE BASED ON THE PRESENCE OF MOSTLY COMMON COHESIVE SOIL CONDITIONS (SILTY OR SANDY CLAY), WITH AN AVERAGE UNCONFINED COMPRESSIVE STRENGTH (QU) > 1.25 TON/SQ. FT. WHICH MUST BE DETERMINED BY PREVIOUS SOIL INVESTIGATIONS AT THE JOBSITE. WHEN OTHER CONDITIONS ARE INDICATED, THE BORING DATA SHALL BE INCLUDED IN THE PLANS AND THE FOUNDATION DIMENSIONS SHOWN SHALL BE THE RESULT OF SITE SPECIFIC DESIGNS. IF CONDITIONS ENCOUNTERED IN THE FIELD ARE DIFFERENT THAN THOSE INDICATED, THE CONTRACTOR SHALL NOTIFY THE ENGINEER TO DETERMINE IF THE FOUNDATION DIMENSIONS NEED TO BE MODIFIED.

LEGEND:
F.F. - FRONT FACE
B.F. - BACK FACE
CTS. - CENTERS

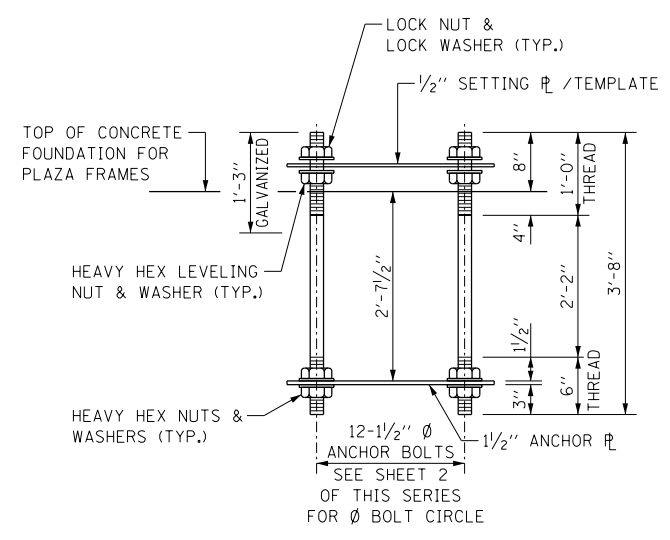

ANCHOR BOLT ASSEMBLY

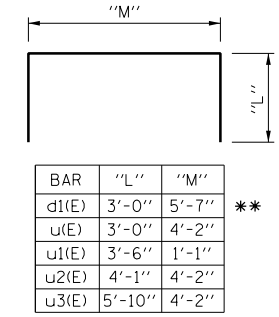

BARS d1(E), u(E), u1(E), u2(E) AND u3(E)

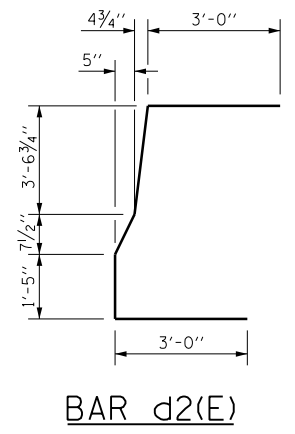

- NOTES:**
- QUANTITIES FOR SINGLE FACE BARRIER FOUNDATION ARE DETERMINED USING "C" = 1'-0". IF DIMENSION "C" IS GREATER THAN 1'-0", ADJUST QUANTITIES ACCORDINGLY.
 - SITE GROUNDING ELECTRODE SYSTEM TO BE PROVIDED AS INDICATED ON THE PLANS.
 - PROTECTIVE COAT SHALL BE APPLIED TO THE TRAFFIC AND TOP FACES OF THE BARRIER AND TOP OF GUTTER.

FRAME COLUMN	"N"	"O"
HSS 16x0.500	2'-0"	1'-4"
HSS 18x0.500	2'-2"	1'-6"

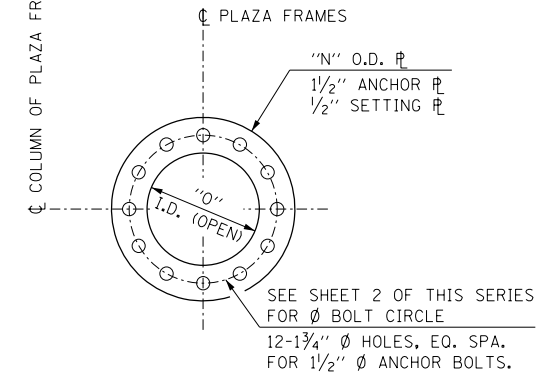

ANCHOR PLATE / SETTING PLATE BAR LIST-ONE FOUNDATION

BAR	NO.		SIZE	LENGTH	SHAPE
	SINGLE FACE BARRIER FDN.	MEDIAN BARRIER FDN.			
d1(E)	5	10	#6	11'-7"	□
d2(E)	5	10	#6	11'-9"	□
s(E)	1		#4	35'-7"	WWW
s1(E)		1	#4	35'-7"	WWW
v(E)	16		#10	35'-7"	—
v1(E)		16	#10	35'-7"	—
u(E)	10	10	#5	10'-2"	□
u1(E)	5	10	#5	8'-1"	□
u2(E)	4		#5	12'-4"	□
u3(E)		4	#5	15'-10"	□

* THE LENGTH OF SPIRAL SHOWN IS THE HEIGHT OF SPIRAL, COMPUTED USING "C" = 1'-0". ADJUST LENGTH ACCORDINGLY IF "C" IS GREATER THAN 1'-0".

** BAR LENGTH IS COMPUTED USING "C" = 1'-0". ADJUST BAR LENGTH ACCORDINGLY IF "C" IS GREATER THAN 1'-0".

ESTIMATED QUANTITY

ITEM	UNIT	SINGLE FACE BARRIER FDN.	MEDIAN BARRIER FDN.
CLASS SI CONCRETE	CU. YD.	4.6	4.7
CLASS DS CONCRETE	CU. YD.	10.7	10.7
REINFORCEMENT BARS EPOXY COATED	POUND	3,310	3,540
PROTECTIVE COAT	SQ. YD.	6.0	8.0

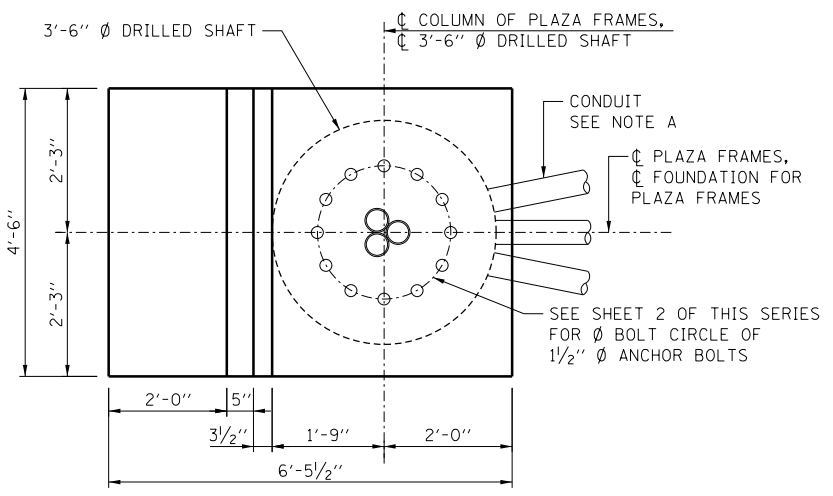

SINGLE FACE BARRIER FOUNDATION FOR PLAZA FRAMES

Paul Kovacs
APPROVED... CHIEF ENGINEER... DATE 3-31-2014...

OVERHEAD SIGN STRUCTURE MONOTUBE TYPE (STEEL) MAINLINE STRUCTURE DETAILS

STANDARD F13-02

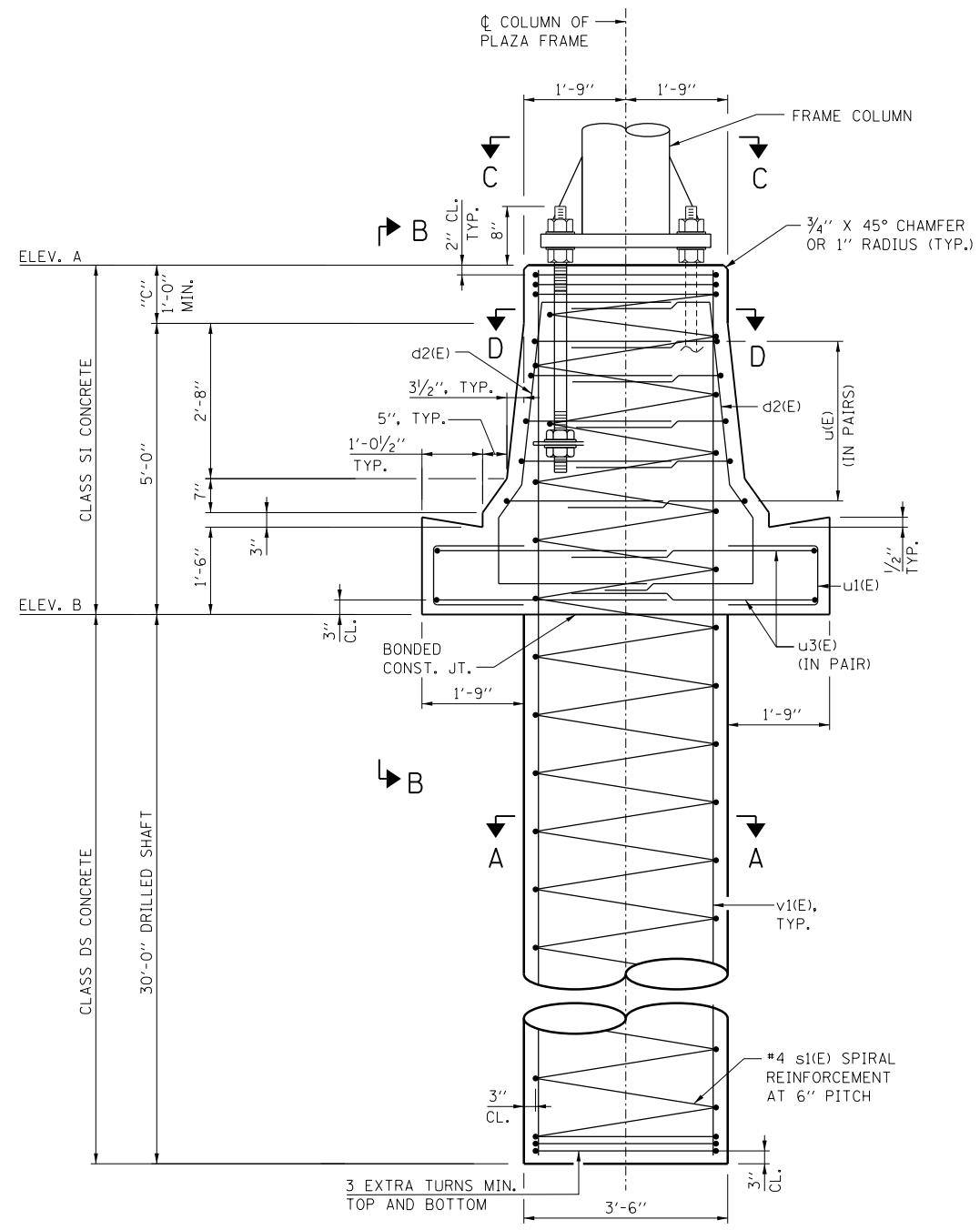

MEDIAN FOUNDATION FOR PLAZA FRAMES

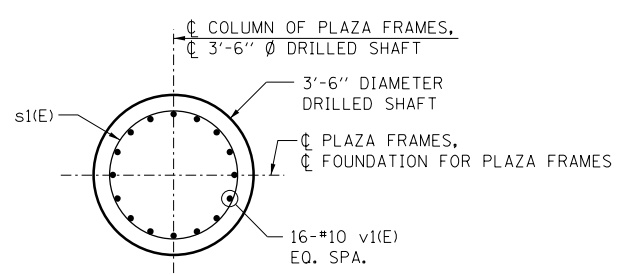

SECTION A-A

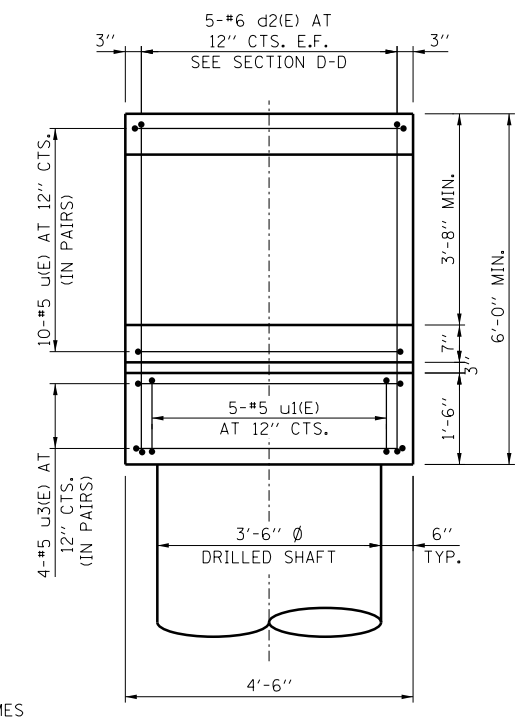

VIEW B-B

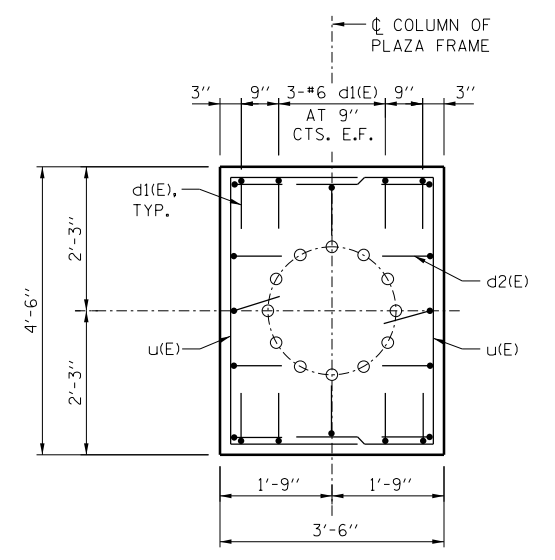

SECTION D-D

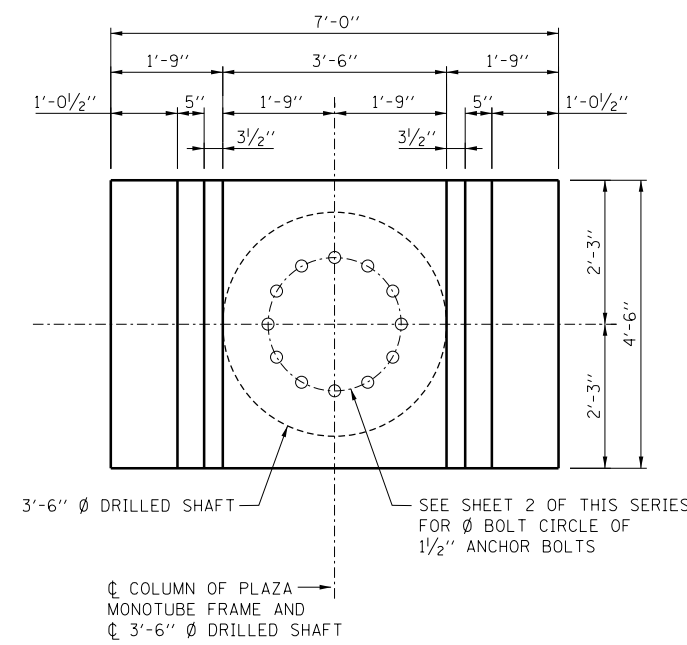

VIEW C-C

NOTES:

1. ANCHOR BOLT ASSEMBLY DETAIL, ANCHOR PLATE DETAIL AND BAR BENDING DIAGRAMS AND QUANTITIES ARE SHOWN ON SHEET 6 OF THIS SERIES.
2. SEE SHEET 6 OF THIS SERIES FOR ADDITIONAL NOTES.
3. SITE GROUNDING ELECTRODE SYSTEM TO BE PROVIDED AS INDICATED ON THE PLANS.

LEGEND:

E.F. - EACH FACE
CTS. - CENTERS

Paul Kovacs
APPROVED... CHIEF ENGINEER... DATE 3-31-2014

OVERHEAD SIGN STRUCTURE
MONOTUBE TYPE (STEEL)
MAINLINE STRUCTURE DETAILS
STANDARD F13-02

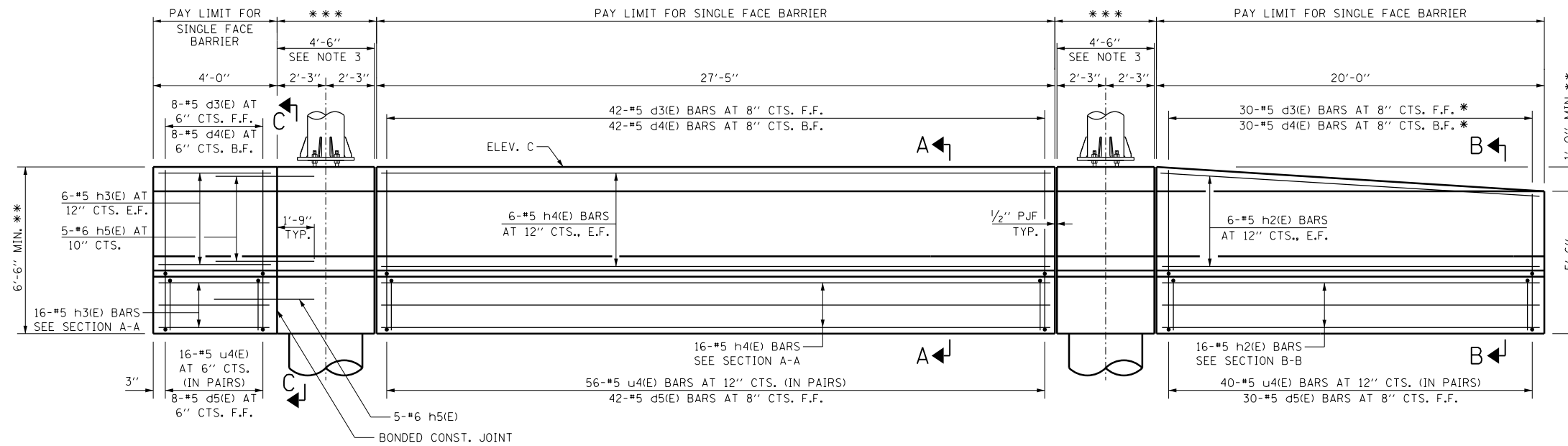

SINGLE FACE BARRIER ELEVATION

INSIDE FACE BARRIER IS SHOWN

- * CUT IN FIELD AS REQUIRED TO FIT TAPER
- ** BASED ON DIMENSION "C" = 1'-0"
- *** PAY LIMIT FOR FOUNDATION FOR OVERHEAD SIGN STRUCTURE

BAR LIST - ONE BARRIER

BAR	NO.	SIZE	LENGTH	SHAPE
d3(E)	80	#5	5'-0"	
d4(E)	80	#5	7'-1"	
d5(E)	80	#5	5'-1"	
h2(E)	28	#5	19'-7"	
h3(E)	28	#5	2'-8"	
h4(E)	28	#5	27'-1"	
h5(E)	10	#6	3'-9"	
u4(E)	112	#5	9'-3"	

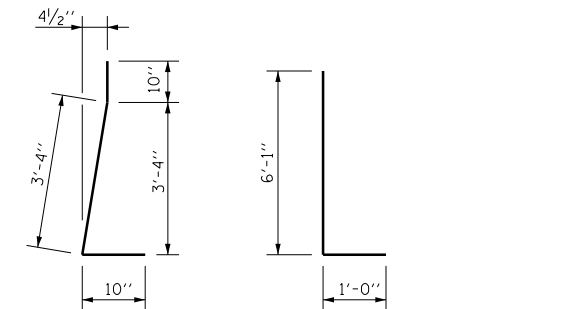

BAR d3(E)

BAR d4(E)

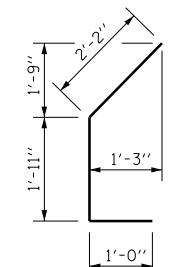

BAR d5(E)

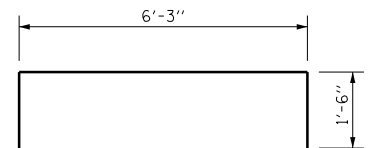

BAR u4(E)

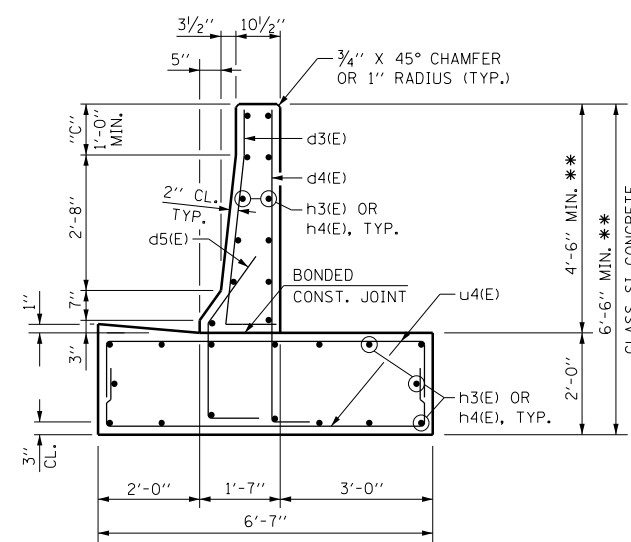

SECTION A-A

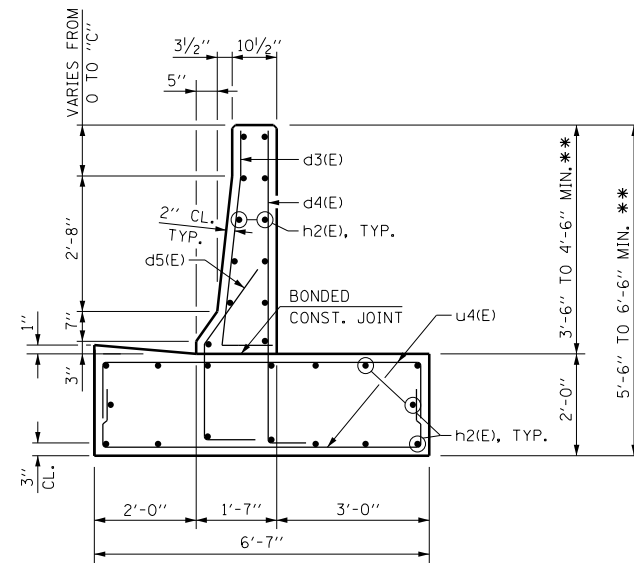

SECTION B-B

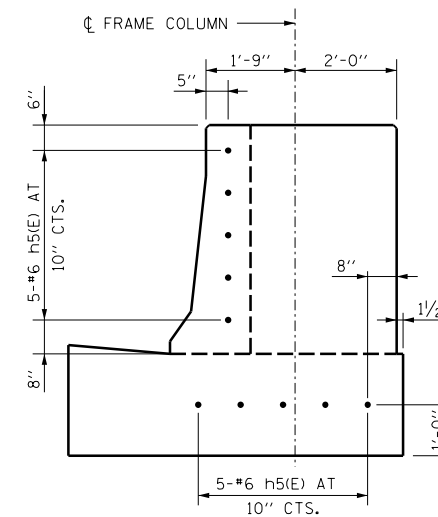

SECTION C-C

ESTIMATED QUANTITY

(FOR ONE SINGLE FACE BARRIER)

ITEM	UNIT	TOTAL
CONCRETE STRUCTURES	CU. YD.	34.2
REINFORCEMENT BARS, EPOXY COATED	POUND	4,008
PROTECTIVE COAT	SQ. YD.	43.0

NOTES:

1. PROTECTIVE COAT SHALL BE APPLIED TO THE TRAFFIC AND TOP FACES OF THE BARRIER, TOP FACE OF THE GUTTER AND TO THE ENTRANCE SIDE FACE (AT THE BEGINNING OF THE PLAZA PAVEMENT) FOR THE FULL HEIGHT OF THE BARRIER.
2. FOR LOCATION OF ELECTRICAL JUNCTION BOXES ON THE WALL, SEE ELECTRICAL DETAIL SHEETS.
3. FOR SINGLE FACE BARRIER FOUNDATION DETAILS FOR PLAZA FRAMES SEE SHEET 6 OF THIS SERIES.
4. QUANTITIES FOR SINGLE FACE BARRIER ARE DETERMINED USING "C" = 1'-0". IF DIMENSION "C" IS GREATER THAN 1'-0", ADJUST QUANTITIES ACCORDINGLY.



ALTERNATE DIRECTION OF HORIZONTAL DIAGONALS FOR EACH BAY IN PLANES OF UPPER AND LOWER CHORDS

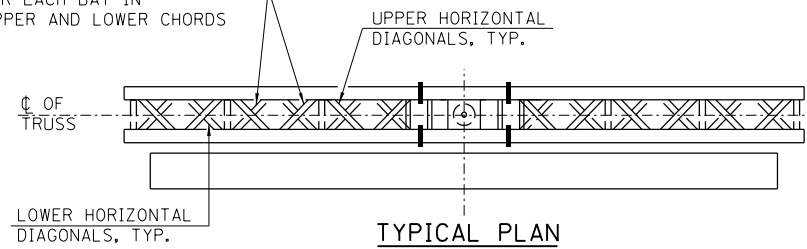

ALTERNATE VERTICAL DIAGONAL BRACING FOR EACH BAY IN PLANES OF FRONT AND BACK CHORDS

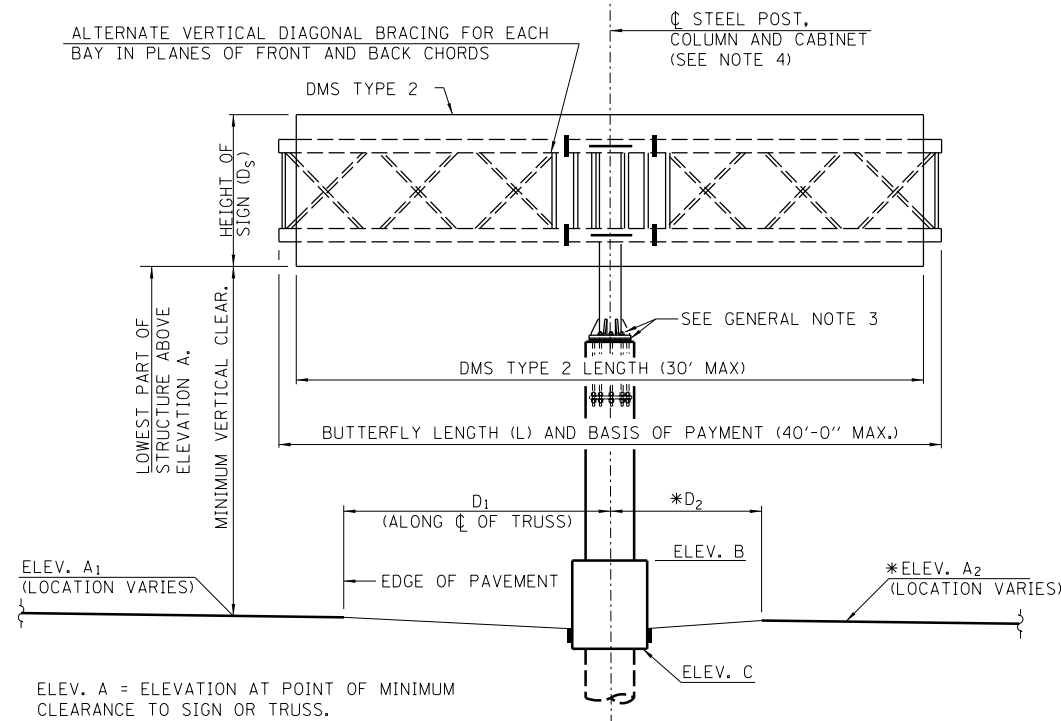

* ELEVATION A₂ AND DIMENSION D₂ NOT USED WHEN BUTTERFLY STRUCTURE IS MOUNTED ON RIGHT SIDE OF THE SHOULDER.

SHOP CAMBER TABLE

UNIT LENGTH L ₁ OR L ₂	SHOP CAMBER AT END
15'	1/4"
20'	1/2"
25'	3/4"

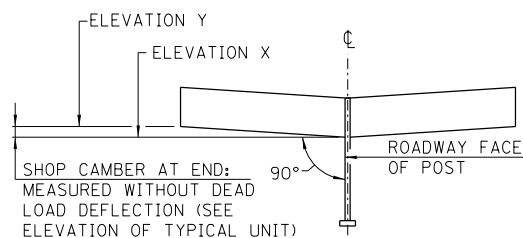

CAMBER DIAGRAM
(FOR FABRICATION ONLY)

APPROVED: *Paul Kovacs* CHIEF ENGINEER DATE 3-31-2014

DMS TYPE 2 TABLE

TRUSS MOUNTING	MAXIMUM TOTAL AREA	MAXIMUM ALLOWABLE WEIGHT
ONE FACE	300 SQ. FT.	5000 LB. - CENTERED ON STRUCTURE
TWO FACE	300 SQ. FT.	6000 LB. - CENTERED ON STRUCTURE

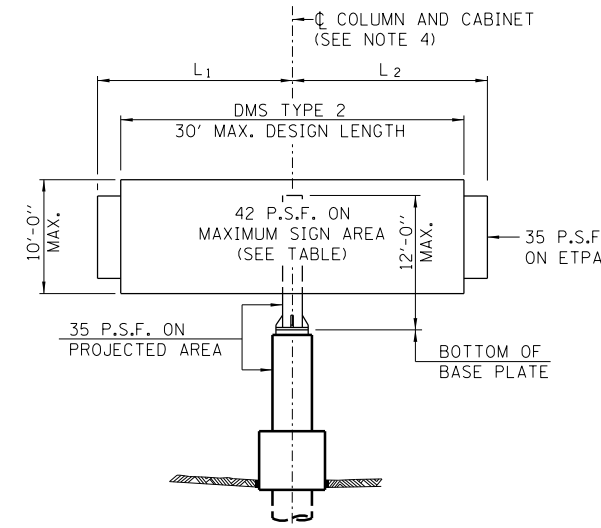

DESIGN WIND LOADING DIAGRAM
ETPA = EFFECTIVE TRUSS PROJECTED AREA

FABRICATION NOTES:

- MATERIALS:** ALL STRUCTURAL STEEL PIPE SHALL BE ASTM A53 GRADE B OR ASTM A106 GRADE B OR API 5L GRADE X42 OR API 5L GRADE X52. ALL STRUCTURAL STEEL TUBE SHALL CONFORM TO ASTM A500 GRADE B. ALL STRUCTURAL STEEL PLATES AND SHAPE SHALL CONFORM TO AASHTO M270 GRADE 50 (M183 OR M223 GRADE 50). STAINLESS STEEL FOR SHIMS, SLEEVES AND HANDHOLE COVERS SHALL BE ASTM A240, TYPE 302 OR 304, OR ANOTHER ALLOY SUITABLE FOR EXTERIOR EXPOSURE AND ACCEPTABLE TO THE ENGINEER. THE STEEL PIPE AND STIFFENING RIBS AT THE BASE PLATE FOR THE COLUMN SHALL HAVE A MINIMUM LONGITUDINAL CHАРPY V-NOTCH (CVN) ENERGY OF 15 LB.-FT. AT 40° F (ZONE 2) BEFORE GALVANIZING.
- WELDING:** ALL WELDS TO BE CONTINUOUS UNLESS OTHERWISE SHOWN. ALL WELDING TO BE DONE IN ACCORDANCE WITH CURRENT AWS D1.1 STRUCTURAL WELDING CODE AND THE STANDARD SPECIFICATIONS.
- FASTENERS:** HIGH STRENGTH BOLTS MUST SATISFY THE REQUIREMENTS OF AASHTO M164 (ASTM A325), OR APPROVED ALTERNATE, AND MUST HAVE MATCHING LOCKNUTS. THREADED STUDS FOR SPLICES (IF MEMBERS INTERFERE) MUST SATISFY THE REQUIREMENTS OF ASTM A449, ASTM A193, GRADE B7, OR APPROVED ALTERNATE, AND MUST HAVE MATCHING LOCKNUTS. BOLTS AND LOCKNUTS NOT REQUIRED TO BE HIGH STRENGTH MUST SATISFY THE REQUIREMENTS OF ASTM A307. ALL BOLTS AND LOCKNUTS MUST BE HOT DIP GALVANIZED PER AASHTO M232, EXCEPT STAINLESS STEEL FASTENERS, NUTS AND WASHERS. THE LOCKNUTS MUST HAVE NYLON OR STEEL INSERTS. A STAINLESS STEEL FLAT WASHER CONFORMING TO ASTM A240 TYPE 302 OR 304, IS REQUIRED UNDER BOTH HEAD AND NUT OR UNDER BOTH NUTS WHERE THREADED STUDS ARE USED. HIGH STRENGTH BOLT INSTALLATION SHALL CONFORM TO ARTICLE 505.04(f)(2)d OF THE IDOT STANDARD SPECIFICATIONS FOR ROAD AND BRIDGE CONSTRUCTION. ROTATIONAL CAPACITY ("ROCAP") TESTING OF BOLTS WILL NOT BE REQUIRED.
- U-BOLTS & EYEBOLTS:** U-BOLTS AND EYEBOLTS MUST BE PRODUCED FROM ASTM A276 TYPE 304, 304L, 316 OR 316L, CONDITION A, COLD FINISHED STAINLESS STEEL, OR AN EQUIVALENT MATERIAL ACCEPTABLE TO THE ENGINEER. ALL NUTS FOR U-BOLTS AND EYEBOLTS MUST BE LOCK NUTS EQUIVALENT TO ASTM A307 WITH NYLON OR STEEL INSERTS AND HOT DIP GALVANIZED PER AASHTO M232. A STAINLESS STEEL FLAT WASHER CONFORMING TO ASTM A240, TYPE 302 OR 304, IS REQUIRED UNDER EACH U-BOLT AND EYEBOLT LOCKNUT.
- GALVANIZING:** ALL STEEL PLATES, SHAPES AND PIPE SHALL BE HOT DIP GALVANIZED AFTER FABRICATION IN ACCORDANCE WITH AASHTO M111. PAINTING IS NOT PERMITTED.
- ANCHOR BOLTS:** SHALL CONFORM TO AASHTO M314 OR ASTM F1554 GRADE 55.

GENERAL NOTES:

- WORK THIS SHEET WITH OVERHEAD SIGN STRUCTURE BUTTERFLY TYPE (STEEL) SUMMARY AND TOTAL BILL OF MATERIAL SHEET.
- AFTER ADJUSTMENTS TO LEVEL TRUSS AND ENSURE ADEQUATE VERTICAL CLEARANCE, ALL TOP AND BOTTOM LEVELING NUTS SHALL BE TIGHTENED AGAINST THE BASE PLATE WITH A MINIMUM TORQUE OF 200 LB.-FT. STAINLESS STEEL MESH SHALL THEN BE PLACED AROUND THE PERIMETER OF THE BASE PLATE. SECURE TO BASE PLATE WITH STAINLESS STEEL BANDING.
- CENTERLINE DMS TYPE 2 MUST BE LOCATED AT CENTERLINE OF COLUMN.
- SIGN SUPPORT STRUCTURES MAY BE SUBJECT TO DAMAGING VIBRATIONS AND OSCILLATIONS WHEN DMS ARE NOT IN PLACE DURING ERECTION OR MAINTENANCE OF THE STRUCTURE. TO AVOID THESE VIBRATIONS AND OSCILLATIONS, CONSIDERATION SHOULD BE GIVEN TO ATTACHING TEMPORARY BLANK SIGN PANELS TO THE STRUCTURE.
- TRUSSES SHALL BE SHIPPED INDIVIDUALLY WITH ADEQUATE PROVISION TO PREVENT DETRIMENTAL MOTION DURING TRANSPORT. THIS MAY REQUIRE ROPES BETWEEN HORIZONTALS AND DIAGONALS OR ENERGY DISSIPATING (ELASTIC) TIES TO THE VEHICLE. THE CONTRACTOR IS RESPONSIBLE FOR MAINTAINING THE CONFIGURATION AND PROTECTION OF THE TRUSSES.
- PROVIDE RUBBED SURFACE FINISH FOLLOWED BY CONCRETE SEALER APPLICATION ON ENTIRE SURFACE OF CONCRETE COLUMN AND ALL SURFACES OF CRASHWALL, EXCEPT BOTTOM SURFACE. COST IS INCLUDED IN THE COST OF "FOUNDATION FOR OVERHEAD SIGN STRUCTURE, BUTTERFLY TYPE."
- REINFORCEMENT BARS: REINFORCEMENT BARS DESIGNATED (E) SHALL BE EPOXY COATED IN ACCORDANCE WITH THE STANDARD SPECIFICATIONS.
- PARAMETERS SHOWN ARE BASIS FOR THIS STANDARD. INSTALLATION NOT WITHIN DIMENSIONAL LIMITS SHOWN REQUIRE SPECIAL ANALYSIS FOR ALL COMPONENTS.
- IT IS PERMISSIBLE TO MOUNT TWO DMS TYPE 2 ON THE BUTTERFLY TRUSS, ONE ON EACH FACE OF THE TRUSS. THE TOTAL COMBINED DEPTH OF DMS TYPE 2 SHALL NOT EXCEED 4'-4" AND THE TOTAL COMBINED WEIGHT SHALL NOT EXCEED 6000 LB. CENTER THE DMS TYPE 2 ON ϕ STEEL POST. DO NOT INSTALL SIGN PANEL IN CONJUNCTION WITH DMS TYPE 2 SIGN CABINETS ON ONE FACE OF THE TRUSS. A SIGN PANEL ON ONE FACE AND DMS TYPE 2 ON THE OTHER IS PERMITTED.

CONSTRUCTION SPECIFICATIONS:

- ALL MATERIALS, EXCEPT AS SHOWN, FABRICATION, ERECTION AND CONSTRUCTION REQUIREMENTS SHALL BE IN ACCORDANCE WITH SECTION 733 AND 734 OF THE LATEST ILLINOIS TOLLWAY SUPPLEMENTAL SPECIFICATIONS.
- THE COST OF FURNISHING AND INSTALLING THE STAINLESS STEEL BAND AND WIRE MESH CLOTH IS INCLUDED IN THE COST OF OVERHEAD SIGN STRUCTURE, BUTTERFLY TYPE (STEEL).

LOADING:

- 90 M.P.H. WIND VELOCITY. WIND LOADING: 42 P.S.F. NORMAL TO DMS TYPE 2 CABINET AREA AND 35 P.S.F. NORMAL TO TRUSS ELEMENTS NOT BEHIND SIGN LOADING DIAGRAM.
- THE AASHTO GROUP II AND III ALLOWABLE STRESS SHALL BE 133% (ALLOWABLE STRESS DESIGN).

DESIGN SPECIFICATIONS:

THESE STRUCTURES ARE DESIGNED TO SATISFY THE 2013 AASHTO STANDARD SPECIFICATIONS FOR STRUCTURAL SUPPORTS FOR HIGHWAY SIGNS, LUMINAIRES AND TRAFFIC SIGNALS, SIXTH EDITION.

CONCRETE COLUMN, CRASHWALL AND DRILLED SHAFT ARE DESIGNED IN ACCORDANCE WITH THE 2012 EDITION OF THE AASHTO LRFD BRIDGE DESIGN SPECIFICATIONS (INCLUDING THE 2013 INTERIM REVISIONS).

DESIGN UNIT STRESSES FOR REINFORCED CONCRETE:

CLASS SI CONCRETE: $f'_c = 3,500$ P.S.I.
CLASS DS CONCRETE: $f'_c = 4,000$ P.S.I.
REINFORCING STEEL: $f_y = 60,000$ P.S.I.



DATE	REVISIONS
7-01-2014	REVISED NOTES
3-11-2015	REVISED NOTES
3-31-2016	ADDED FOUNDATION NOTE AND REMOVED WALKWAY GRATING

OVERHEAD SIGN STRUCTURE
BUTTERFLY TYPE
STRUCTURE DETAILS

STANDARD F14-02

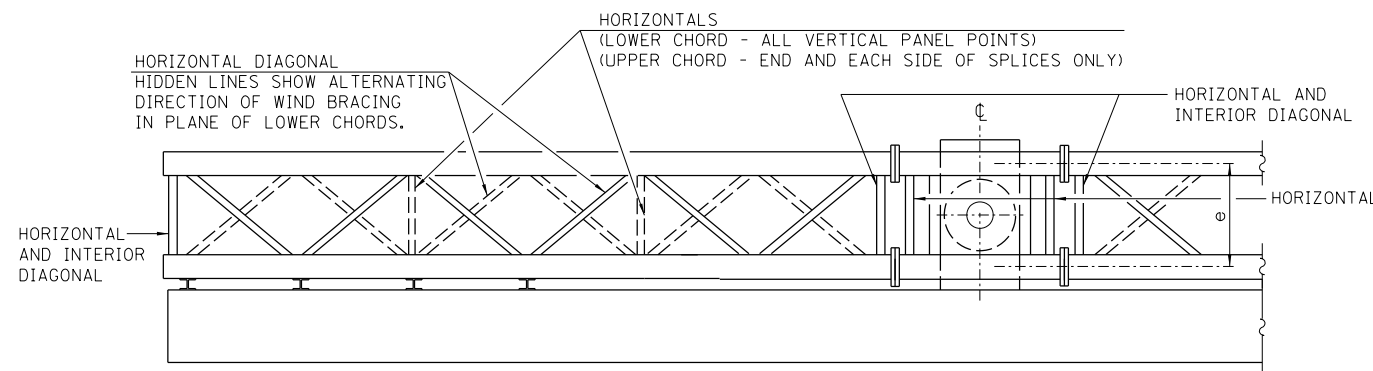

PLAN

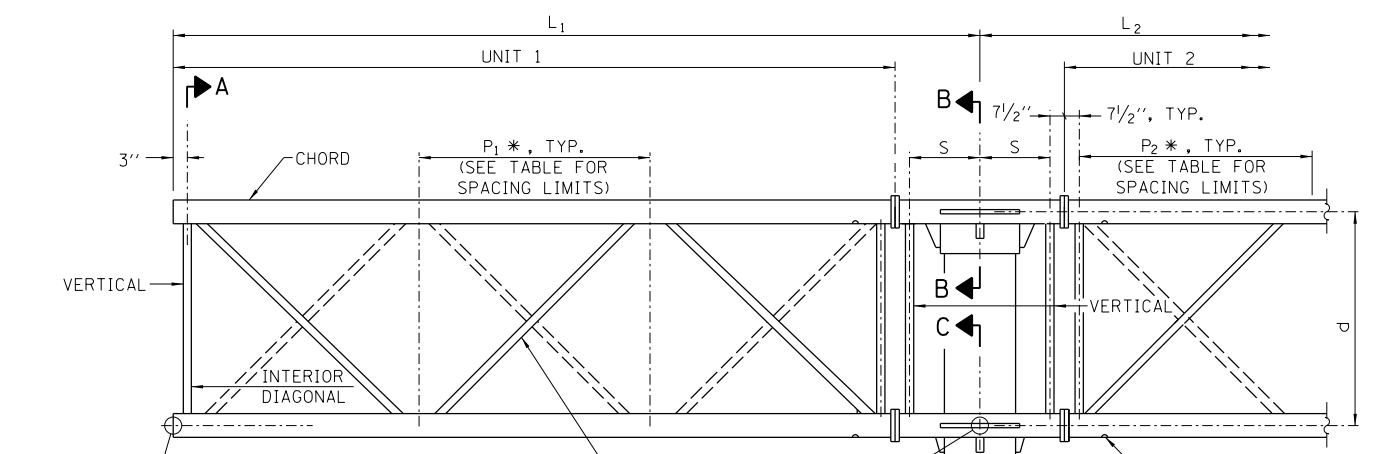

ELEVATION

TYPICAL TRUSS UNIT

FOR SECTION B-B AND SECTION C-C, SEE SHEET 3 OF THIS SERIES

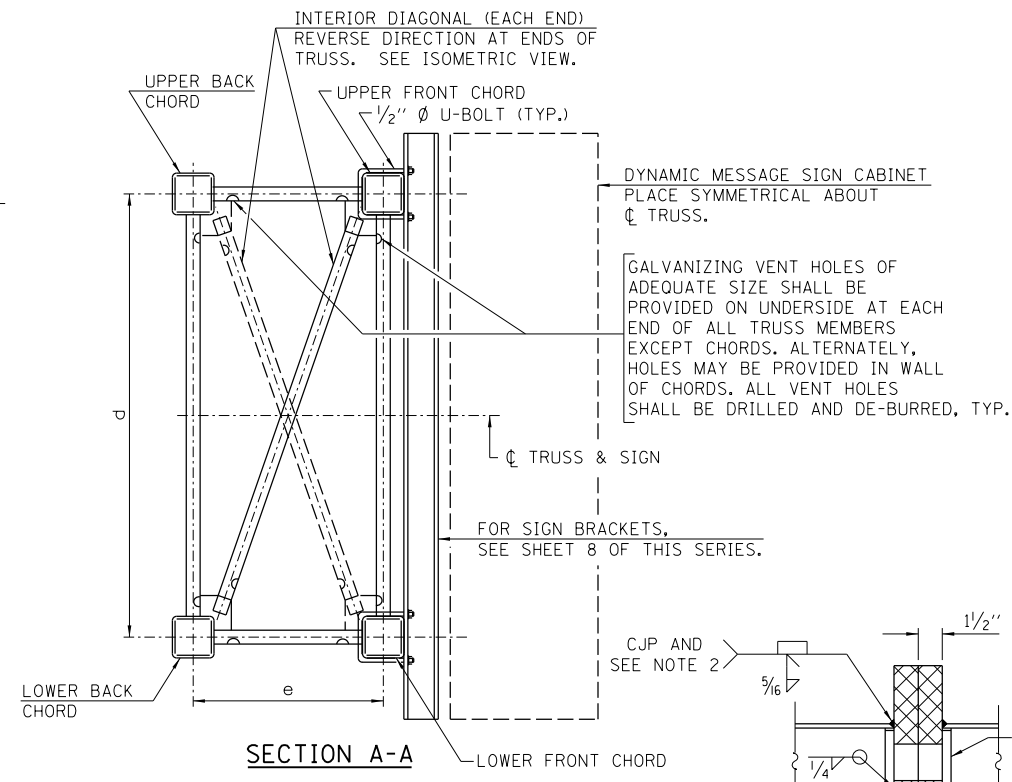

SECTION A-A

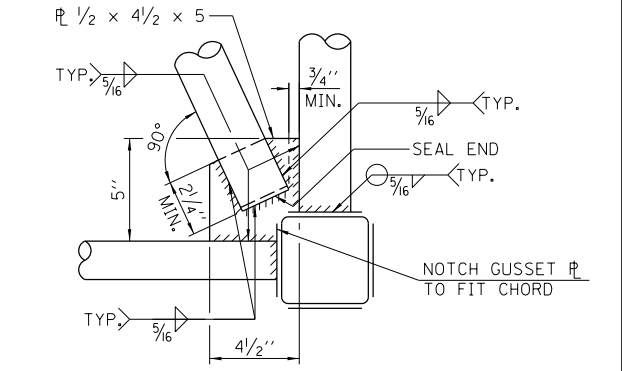

GUSSET P FOR INTERIOR DIAG. DETAIL

BOLT DIA.	A	B
1/4"	11 1/2"	15"

SECTION D-D

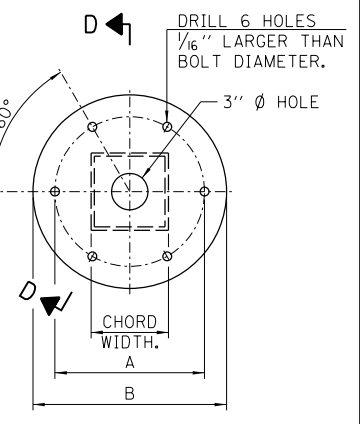

SPlicing FLANGE

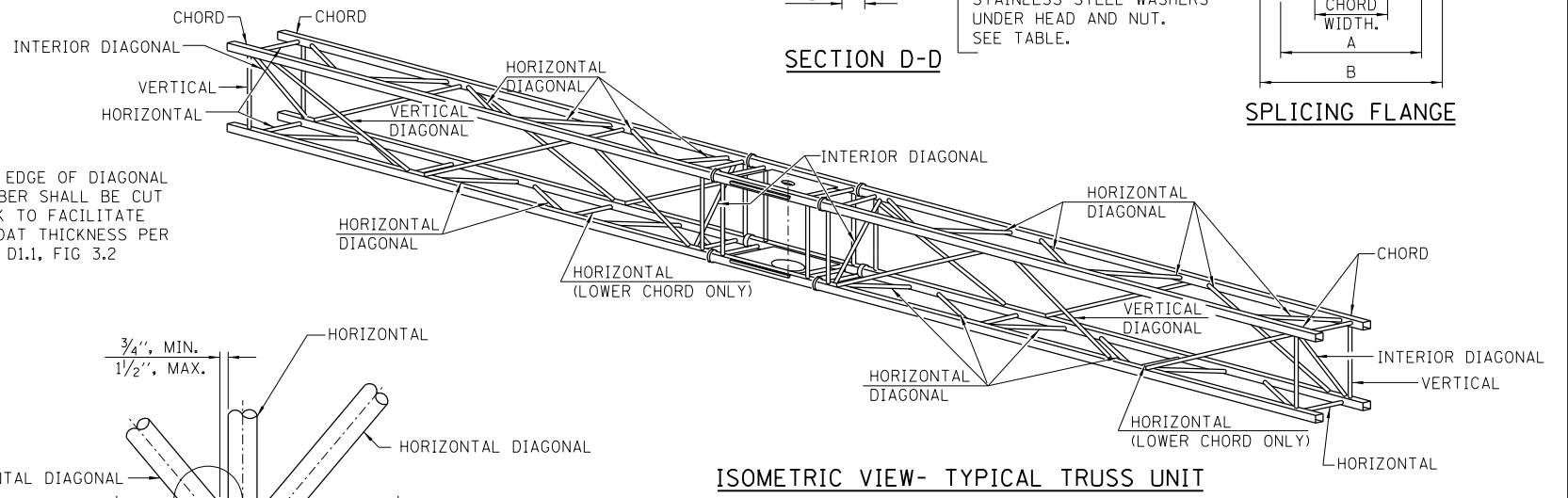

ISOMETRIC VIEW- TYPICAL TRUSS UNIT

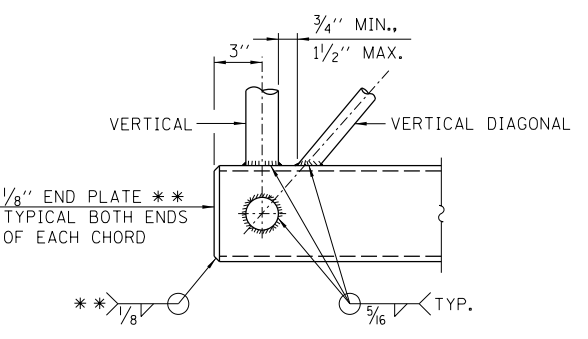

BUTTERFLY END JOINT DETAIL

** CONTRACTOR MAY ALTERNATIVELY USE STANDARD STEEL DRIVE-FIT CAP TO CLOSE ENDS. 1/2" Ø DRAIN HOLE IN END PLATE / DRIVE-FIT CAP.

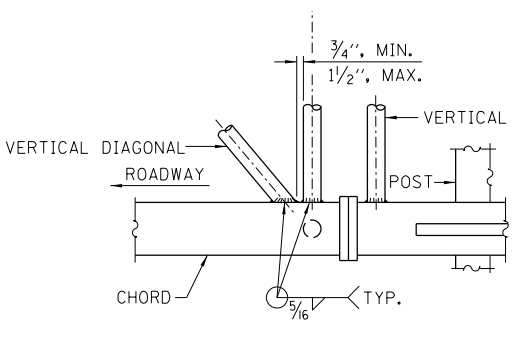

POST END JOINT DETAIL

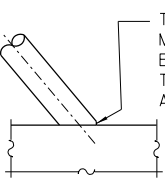

DETAIL A

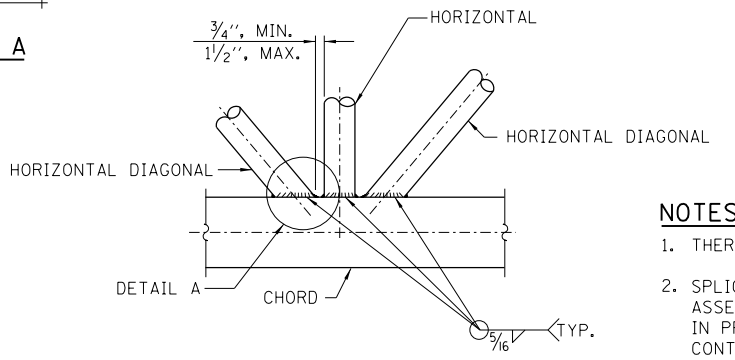

TRUSS INTERIOR JOINT DETAIL

NOTES:

1. THERE ARE TWICE AS MANY HORIZONTAL DIAGONALS AS THERE ARE VERTICAL DIAGONALS.
2. SPlicing FLANGES SHALL BE ATTACHED TO EACH TRUSS UNIT WITH THE TRUSS SHOP ASSEMBLED TO CAMBER SHOWN ON SHEET 1 OF THIS SERIES. TRUSS UNITS SHALL BE IN PROPER ALIGNMENT AND FLANGE SURFACES SHALL BE SHOP BOLTED INTO FULL CONTACT BEFORE WELDING. SUFFICIENT EXTERNAL WELDS OR TACKS SHALL BE MADE TO SECURE FLANGES UNTIL REMAINING WELDS ARE MADE AFTER DISASSEMBLY. ADJACENT FLANGES SHALL BE "MATCH MARKED" TO INSURE PROPER FIELD ASSEMBLY.
3. NOMINAL WALL THICKNESS SHOWN. THICKER WALL IS PERMITTED UPON ENGINEER'S APPROVAL.

TRUSS UNIT TABLE

TRUSS SIZE		MAXIMUM DMS TYPE 2 SIGN LENGTH	STEEL SUPPORT POST (COLUMN)				TRUSS MEMBERS AND DETAILS						LIMITS FOR PANEL SPACING (P) *	DIMENSION S
e	d		DIAMETER	WEIGHT	WALL THICKNESS (SEE NOTE 3)	H (MAX.)	TOP & BOTTOM CHORD	VERTICAL	VERTICAL DIAG.	HORIZONTAL	HORIZONTAL DIAG.	INTERIOR DIAG.		
3'-9"	7'-0"	30'-0"	24"	125.61 (#/FT)	1/2"	12'-0"	HSS 6x6x3/16	3"Ø X.S	4"Ø X.X.S	2"Ø X.S	2 1/2"Ø X.S	2"Ø X.S	48" MIN. TO 66" MAX.	1'-9"

* P = L-S-1'-6" / # PANELS

APPROVED: *Paul Kovacs* CHIEF ENGINEER DATE 3-31-2014

OVERHEAD SIGN STRUCTURE BUTTERFLY TYPE STRUCTURE DETAILS
STANDARD F14-02

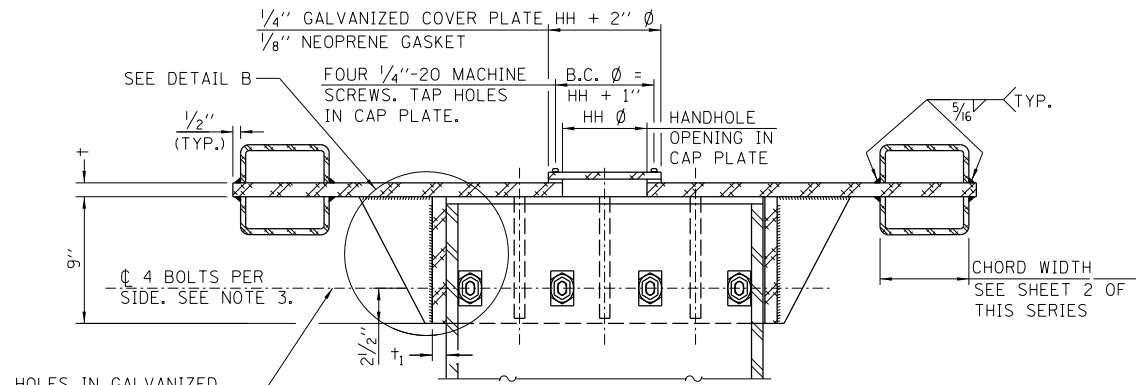

SECTION B-B

BOLTS SHALL BE HIGH STRENGTH WASHERS (INCLUDING CONTOURED WASHERS), AND LOCKNUTS SHALL BE STAINLESS STEEL.

HOLES IN GALVANIZED STEEL POST AND COLLAR = BOLT Ø + 1/16".

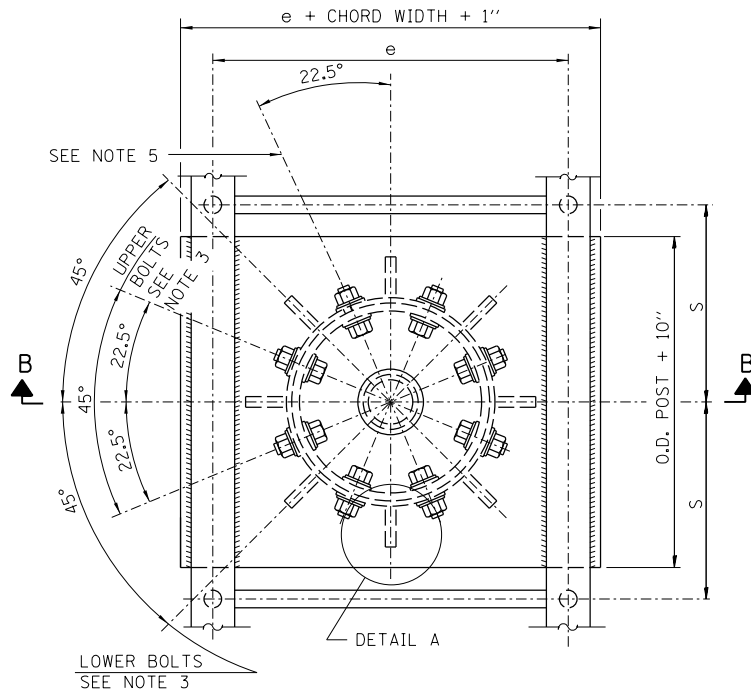

PLAN VIEW - TOP OF COLUMN

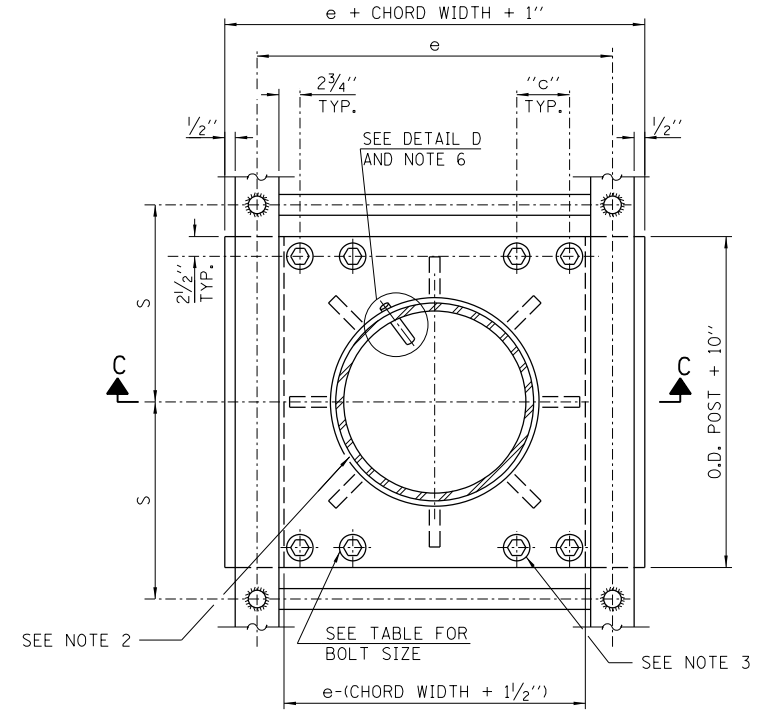

SECTION THRU POST ABOVE LOWER CHORDS

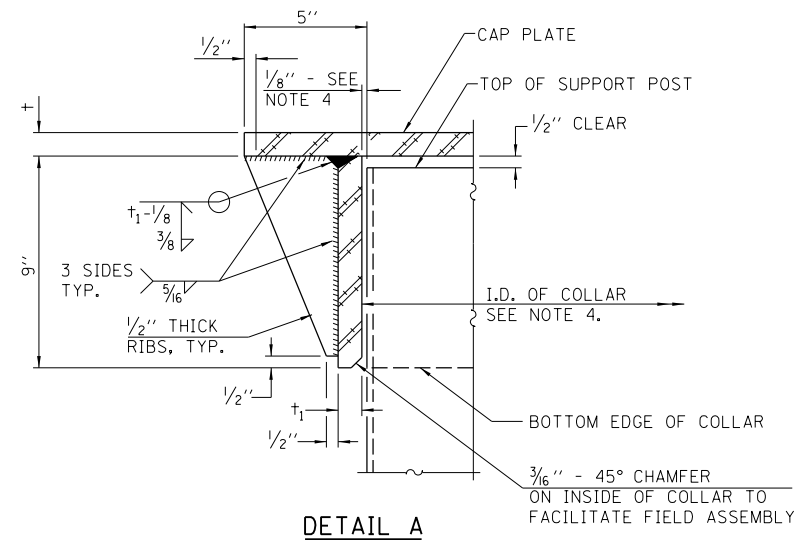

DETAIL A

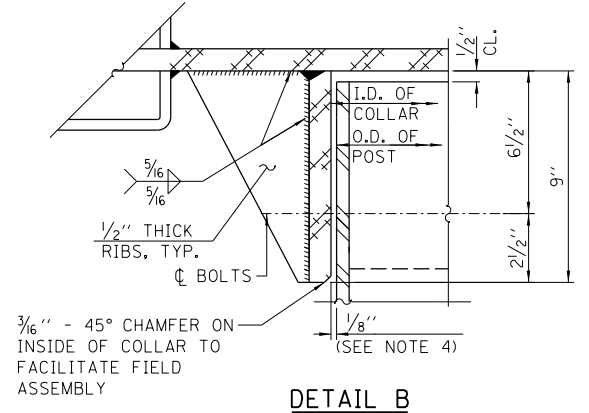

DETAIL B

(FOR DETAILS NOT SHOWN, SEE DETAIL C)

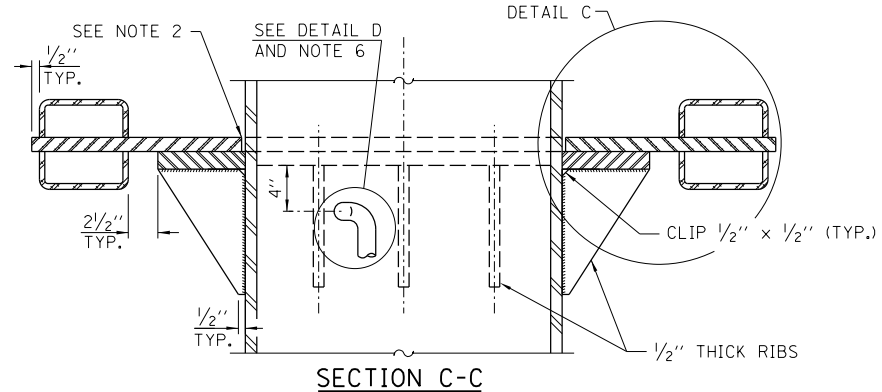

SECTION C-C

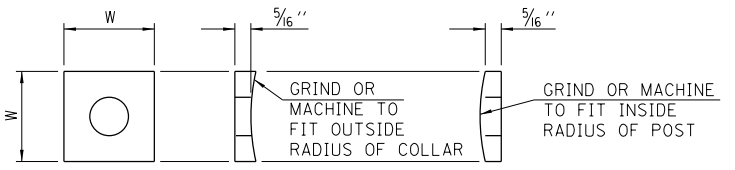

CONTOURED WASHERS

BOLT SIZE	CONTOURED WASHERS	
	HOLE DIA.	W
3/8"	1"	2 1/2"
1"	1 1/8"	3"
1 1/4"	1 3/8"	3 3/4"

(ASTM A240, TYPE 304)

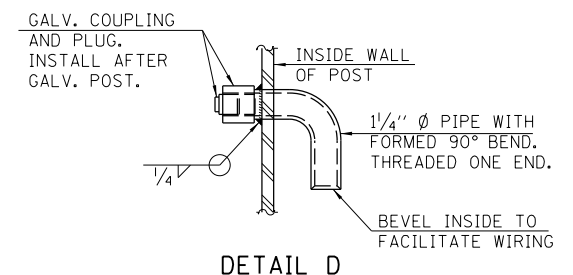

DETAIL D

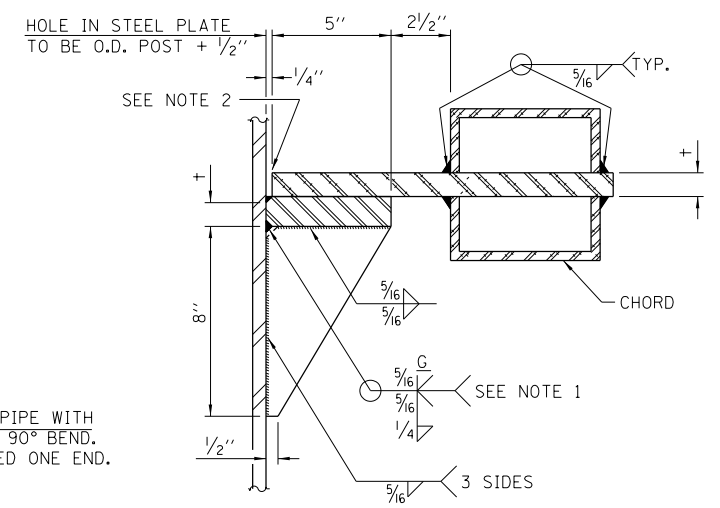

DETAIL C

NOTES:

- GRIND TOP IF REQUIRED TO FULLY SEAT PLATE. REPAIR DAMAGED GALVANIZING BEFORE ASSEMBLY.
- AFTER TIGHTENING LOWER CONNECTION BOLTS, FILL GAP WITH NON-HARDENING, SILICONE CAULK SUITABLE FOR EXTERIOR EXPOSURE AND ACCEPTABLE TO THE ENGINEER. COST IS INCLUDED IN OVERHEAD SIGN STRUCTURE, BUTTERFLY TYPE (STEEL).
- CONNECTION BOLTS IN COLLAR AND BOLTS AT LOWER CHORD CONNECTION MUST BE HIGH STRENGTH WITH MATCHING LOCKNUTS. CONNECTION BOLTS SHALL HAVE TWO STAINLESS STEEL FLAT WASHERS EACH.
- COLLAR I.D. SHALL BE MANUFACTURED TO CORRESPOND TO O.D. OF ACTUAL GALVANIZED POST PLUS 1/8" (± 1/16"). MAXIMUM GAP BETWEEN POST AND COLLAR AT ANY LOCATION EQUALS 1/8" BEFORE TIGHTENING BOLTS.
- OPTIONAL FULL PENETRATION WELD IN COLLAR. (TWO LOCATIONS MAXIMUM (180° APART) X-RAY OR UT 100%)
- ORIENT PIPE TOWARD WALKWAY SIDE. HOLE IN POST = O.D. PIPE + 1/8".

CONNECTION TABLE

POST OUTSIDE DIAMETER	UPPER & LOWER CONNECTION BOLT DIAMETER (SEE NOTE 3)	LOWER JUNCTURE BOLT SPACING DIMENSION "C" (SEE NOTE 3)	OPENING IN CAP PLATE "HH"	PLATE THICKNESS (t)	COLLAR THICKNESS (t ₁)
24"	1 1/4"	3 1/2"	6"	1"	7/8"



OVERHEAD SIGN STRUCTURE BUTTERFLY TYPE STRUCTURE DETAILS

STANDARD F14-02

Paul Kovacs
APPROVED... CHIEF ENGINEER... DATE 3-31-2014

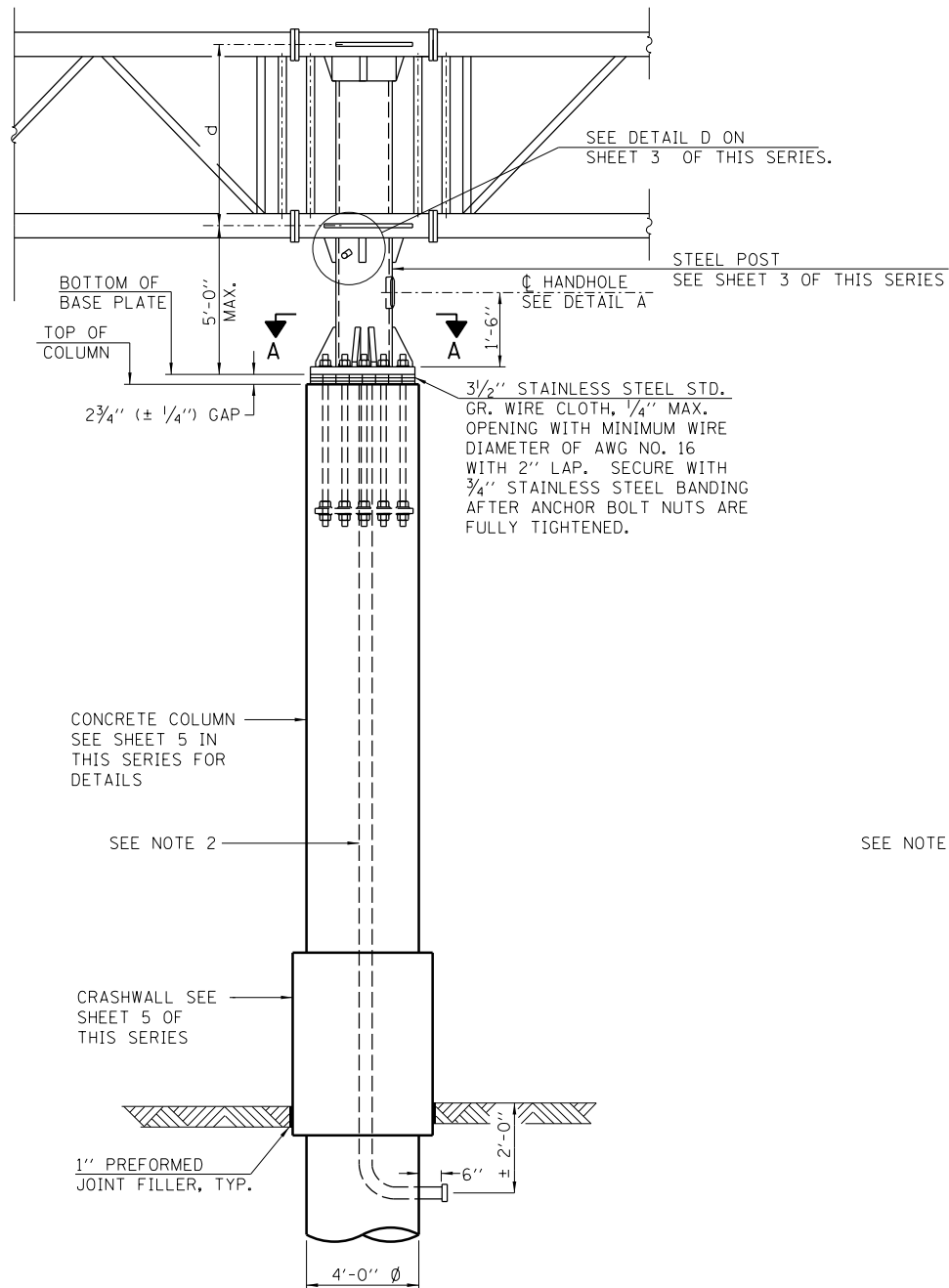

FRONT ELEVATION

SEE SHEET 5 OF THIS SERIES FOR FOUNDATION DETAILS.
(DMS TYPE 2 SIGN CABINET NOT SHOWN FOR CLARITY)

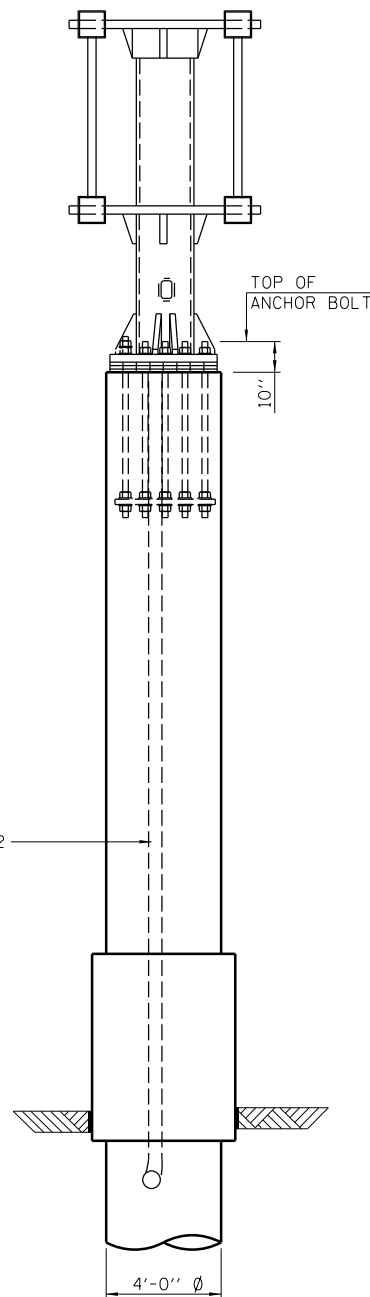

SIDE ELEVATION

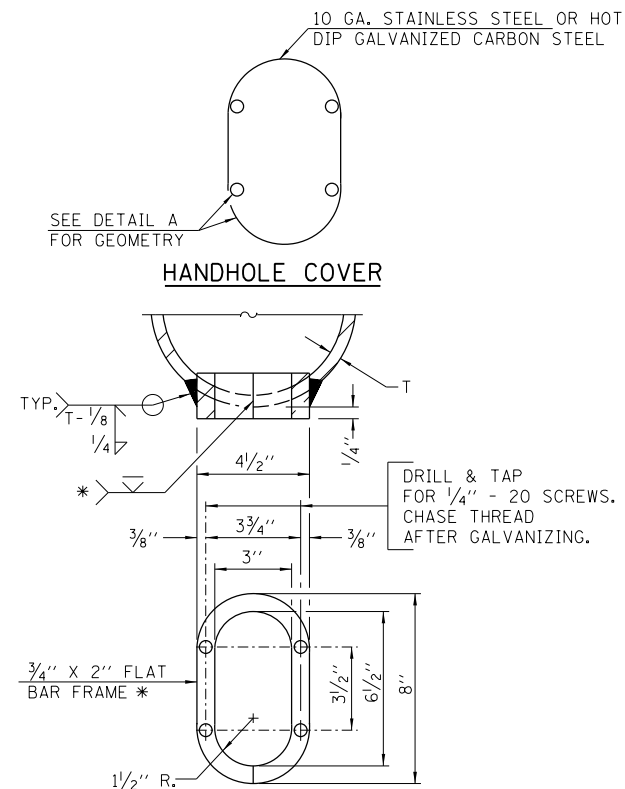

DETAIL A

* BENT BARS MAY BE BUTT WELDED TOP AND BOTTOM OR BOTTOM ONLY. IN LIEU OF FABRICATED HANDHOLE FRAME AS SHOWN, MAY CUT FROM 2" PLATE (ROLLING DIRECTION VERTICAL). ALL CUT FACES TO BE GROUND TO ANSI ROUGHNESS OF 500 μin OR LESS.

NOTE:

1. SITE GROUNDING ELECTRODE SYSTEM TO BE PROVIDED AS INDICATED ON PLANS.
2. SEE PLAN SHEETS FOR TYPE, SIZE AND NUMBER OF CONDUITS.

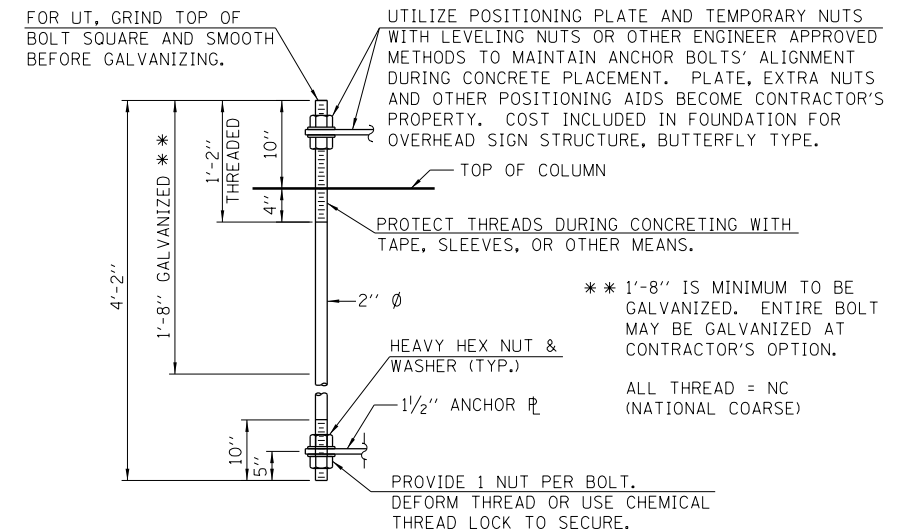

ANCHOR BOLT DETAIL

ANCHOR BOLTS SHALL CONFORM TO AASHTO M314 OR ASTM F1554 GRADE 55. GALVANIZE THE UPPER 1'-8" (MINIMUM (**)) AND ASSOCIATED AASHTO M291, GRADE A, C OR DH HEAVY HEX NUTS AND HARDENED WASHERS PER AASHTO M232. NO WELDING SHALL BE PERMITTED ON BOLTS. PROVIDE A NUT AT BOTTOM, A HEXAGON LOCKNUT AND WASHER ABOVE BASE PLATE AND A LEVELING NUT AND WASHER BELOW BASE PLATE. NUTS SHALL EACH BE TIGHTENED WITH 200 LB.-FT. MINIMUM TORQUE AGAINST BASE PLATE. BEFORE OR AFTER THREADING, BUT BEFORE GALVANIZING, EACH ANCHOR BOLT SHALL BE ULTRASONICALLY TESTED (UT) BY A LEVEL II OR III INSPECTOR, QUALIFIED IN ACCORD WITH ANSI GUIDELINES, TO ENSURE NO REJECTABLE FLAWS EXIST IN THE UPPER 18" (TENSION CRITERIA). COST OF TESTING INCLUDED IN FOUNDATION FOR OVERHEAD SIGN STRUCTURE, BUTTERFLY TYPE.

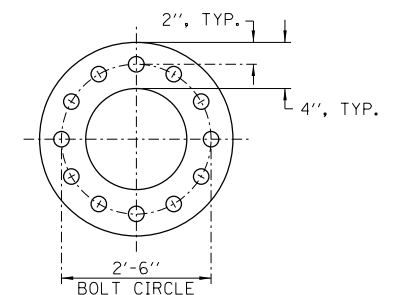

POSITIONING PLATE/ANCHOR PLATE

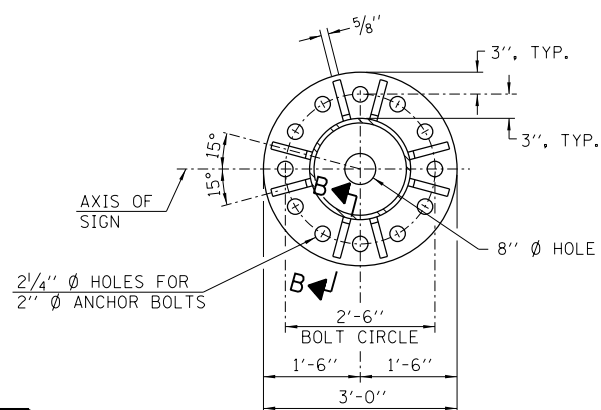

SECTION A-A

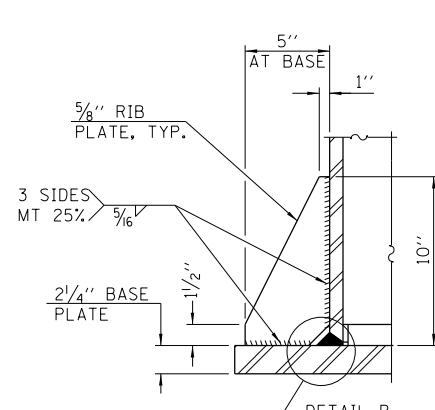

SECTION B-B

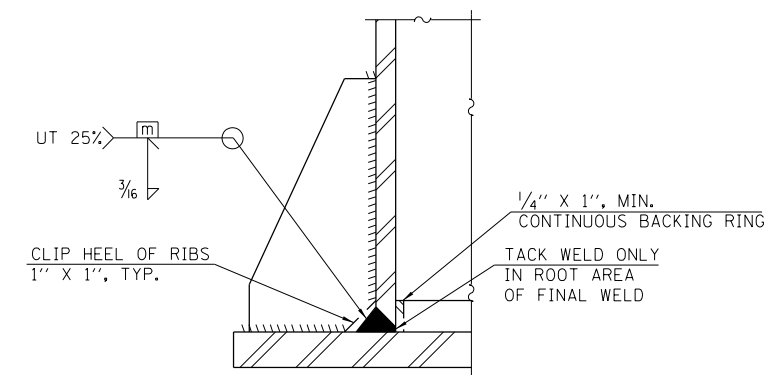

DETAIL B (TYPICAL RIB)



OVERHEAD SIGN STRUCTURE
BUTTERFLY TYPE
STRUCTURE DETAILS

STANDARD F14-02

APPROVED: *Paul Kovacs* CHIEF ENGINEER DATE 3-31-2014

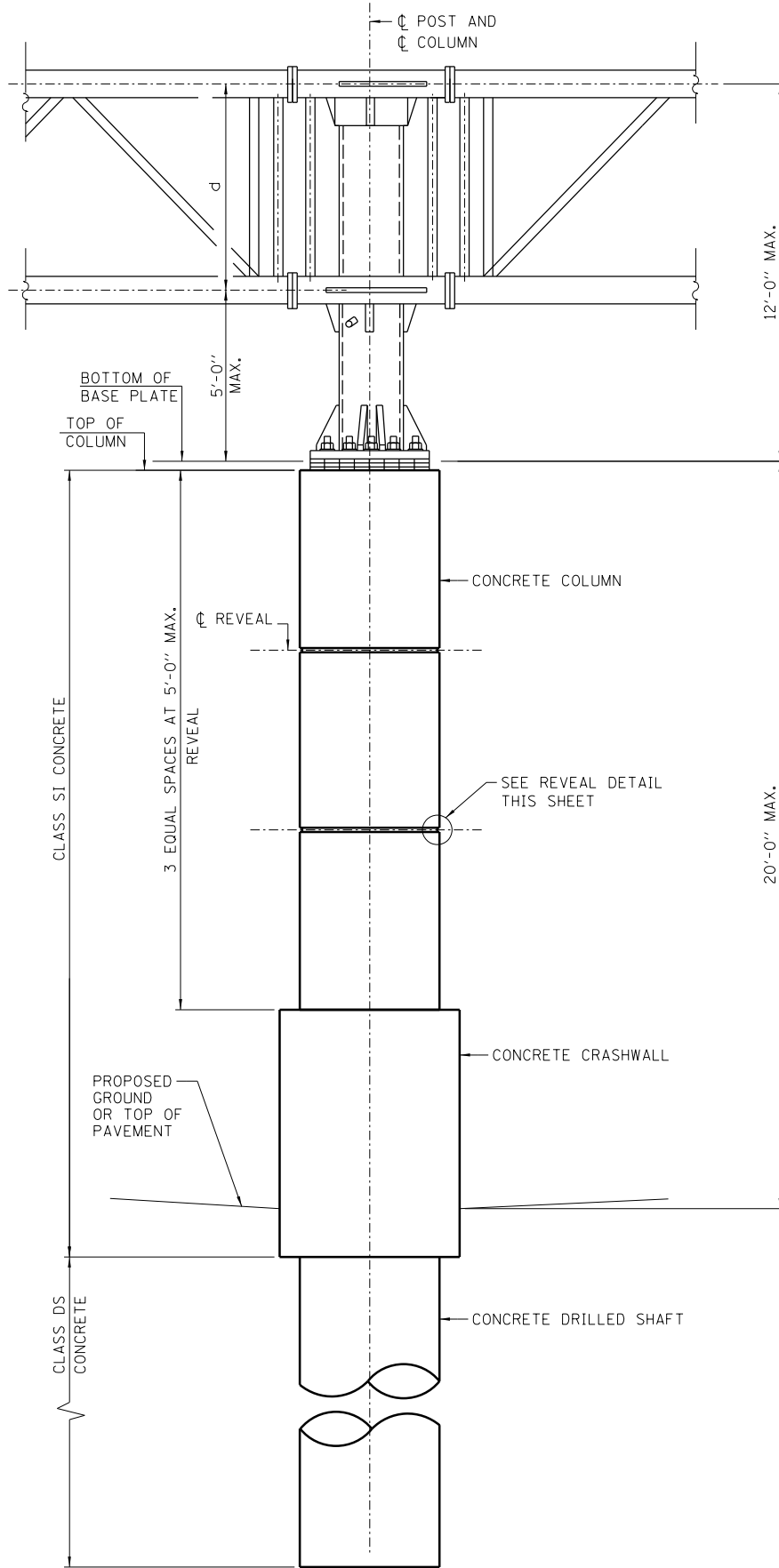

FRONT ELEVATION
DMS TYPE 2 NOT SHOWN FOR CLARITY

BILL OF MATERIAL-EACH FOUNDATION

CLASS S1 CONC. CY	CLASS DS CONC. CY	REBAR POUNDS	PROTECTIVE COAT SQ. YD.
12.9	11.7	4,790	6.0

NOTES:

1. COLUMN CONCRETE VOLUME AND BAR s1(E) LENGTH ARE COMPUTED BASED ON 15'-0" COLUMN HEIGHT. IF COLUMN HEIGHT IS NOT EQUAL 15'-0", QUANTITIES SHALL BE CALCULATED BASED ON ACTUAL COLUMN HEIGHT.
2. PROTECTIVE COAT SHALL BE APPLIED TO TRAFFIC AND TOP FACES OF CRASHWALL.

BAR LIST-EACH FOUNDATION
(COLUMN, CRASHWALL AND DRILLED SHAFT)

BAR	NUMBER	SIZE	LENGTH	SHAPE
v(E)	20	#9	38'-3"	—
v1(E)	20	#9	15'-8"	—
s(E)	1	#4	31'-1"	WWW
s1(E)	1	#4	14'-5"	WWW
u(E)	12	#5	12'-2"	U
u1(E)	18	#5	8'-7"	U

* THE LENGTH OF SPIRAL SHOWN IS THE HEIGHT OF SPIRAL

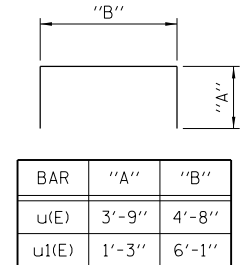

BAR u(E), u1(E)

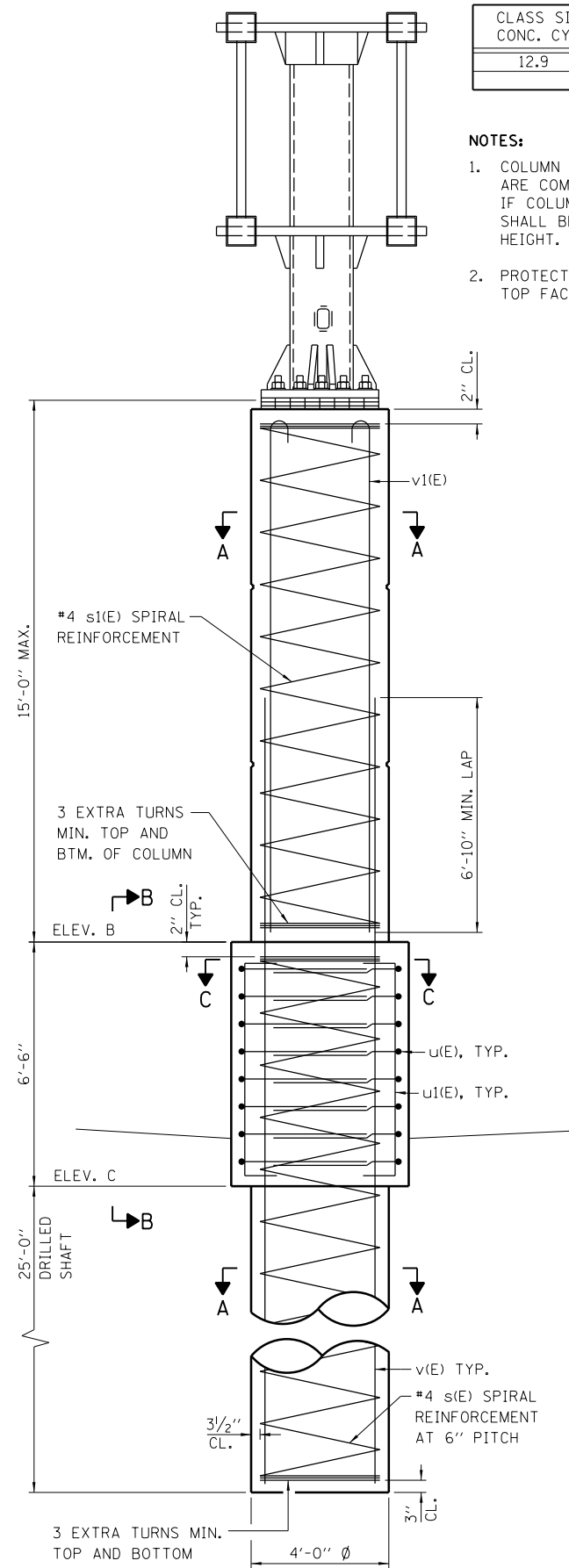

SIDE ELEVATION

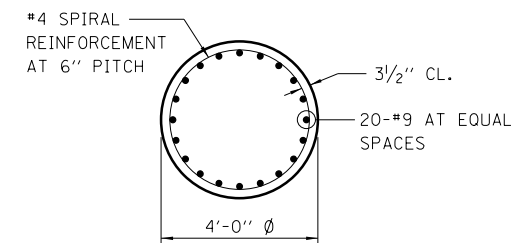

SECTION A-A

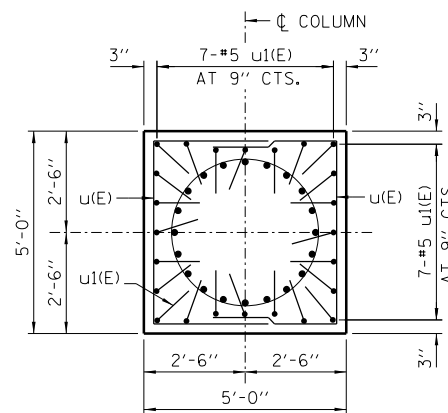

SECTION C-C

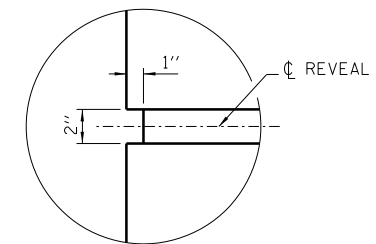

REVEAL DETAIL

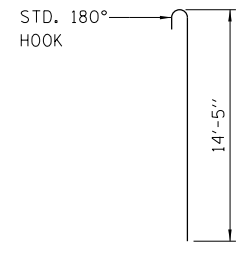

BAR v1(E)

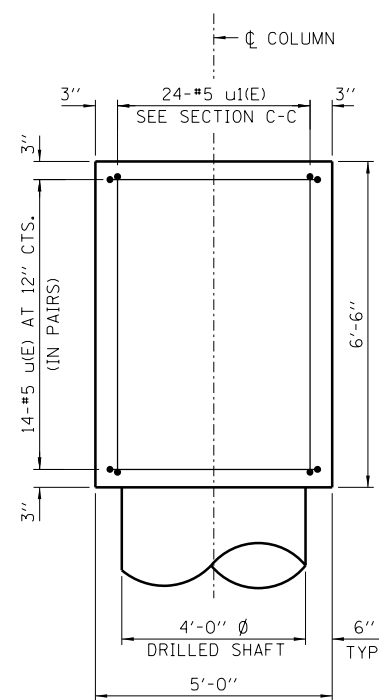

SECTION B-B

FOUNDATIONS:

THE FOUNDATION DETAILS SHOWN ARE BASED ON THE PRESENCE OF MOSTLY COMMON COHESIVE SOIL CONDITIONS (SILTY OR SANDY CLAY), WITH AN AVERAGE UNCONFINED COMPRESSIVE STRENGTH (QU) > 1.25 TON/SQ. FT. WHICH MUST BE DETERMINED BY PREVIOUS SOIL INVESTIGATIONS AT THE JOBSITE. WHEN OTHER CONDITIONS ARE INDICATED, THE BORING DATA SHALL BE INCLUDED IN THE PLANS AND THE FOUNDATION DIMENSIONS SHOWN SHALL BE THE RESULT OF SITE SPECIFIC DESIGNS. IF CONDITIONS ENCOUNTERED IN THE FIELD ARE DIFFERENT THAN THOSE INDICATED, THE CONTRACTOR SHALL NOTIFY THE ENGINEER TO DETERMINE IF THE FOUNDATION DIMENSIONS NEED TO BE MODIFIED.



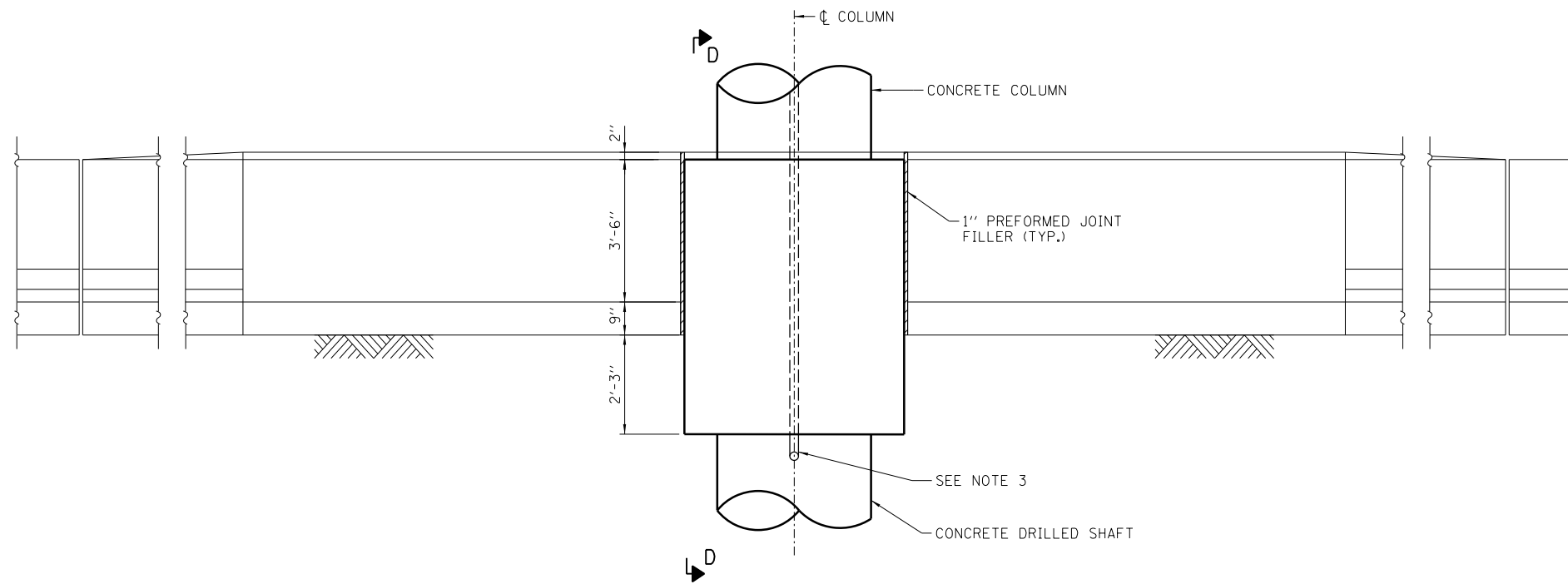

SIDE ELEVATION

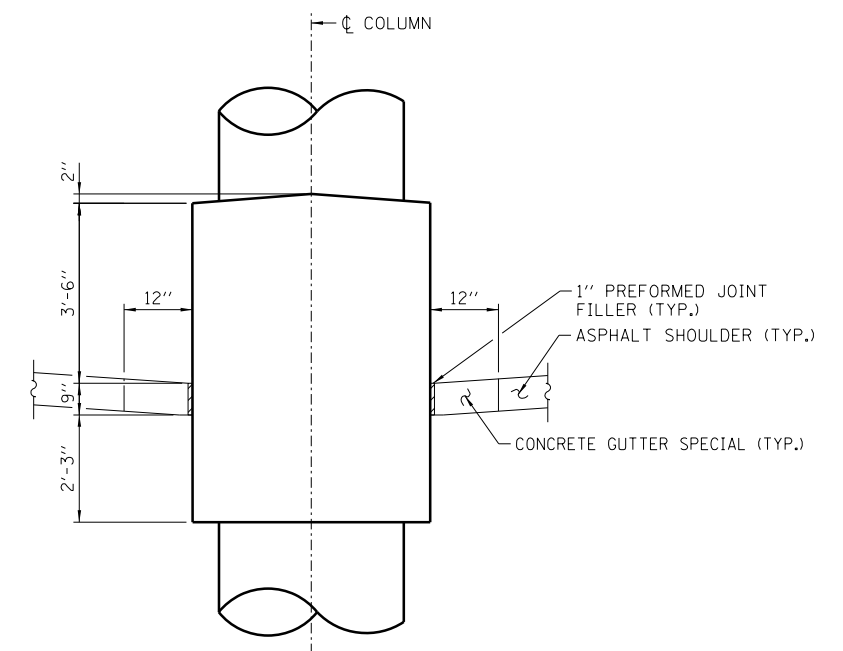

SECTION D-D
FOUNDATION LOCATED IN PAVED ROADWAY MEDIAN

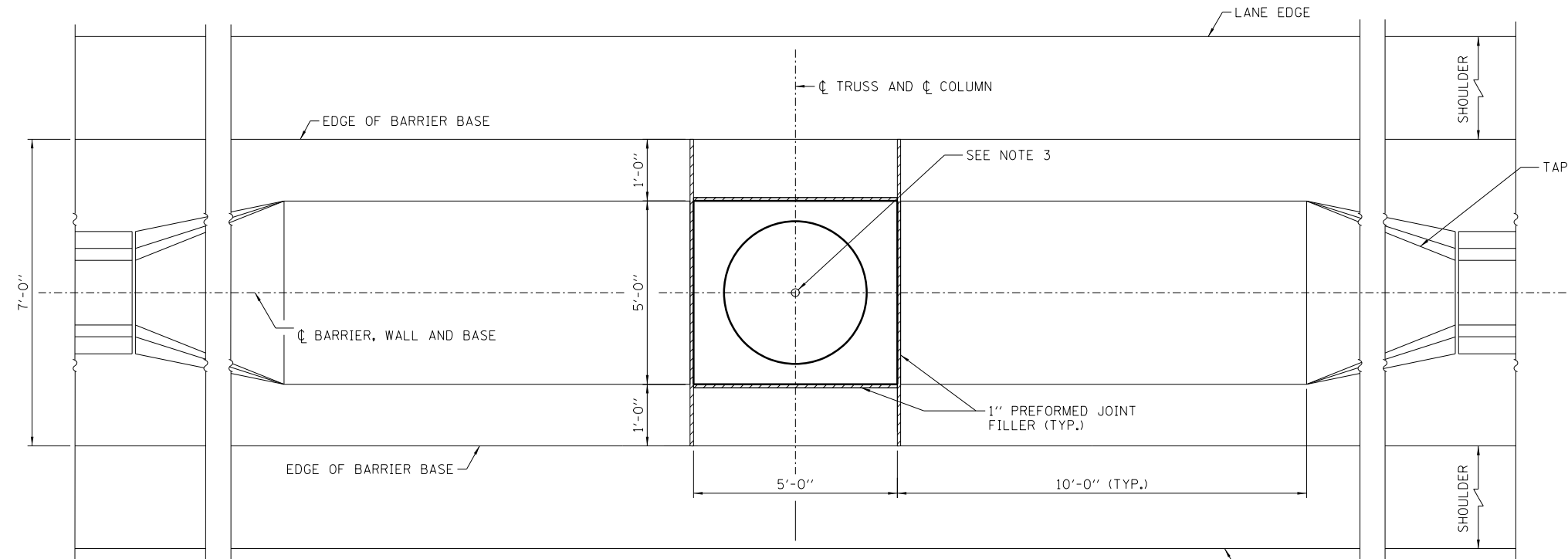

PLAN

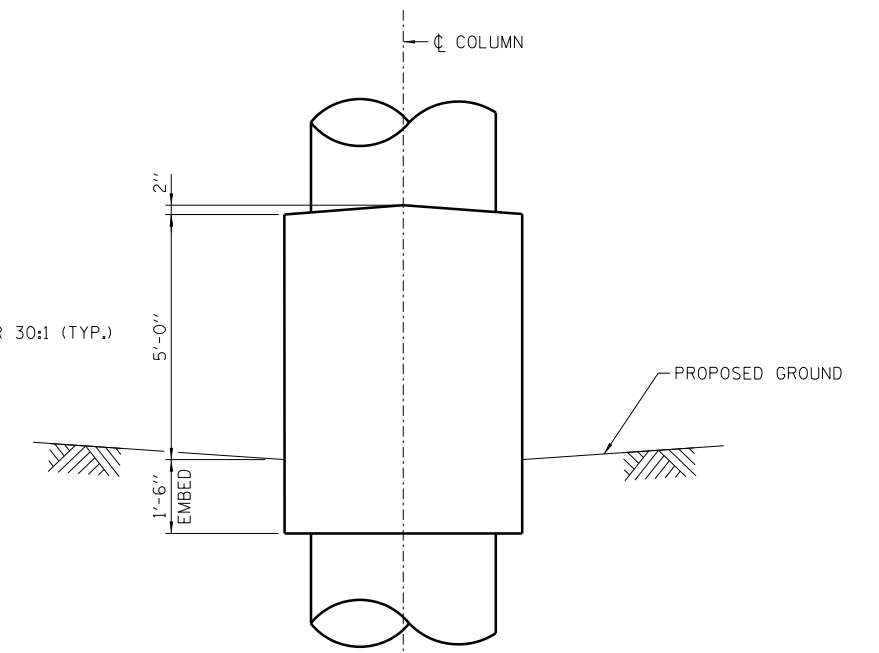

SECTION D-D
FOUNDATION LOCATED IN UNPAVED ROADWAY MEDIAN

NOTES:

1. SIDE ELEVATION AND PLAN VIEW ARE SHOWN FOR FOUNDATION LOCATED IN PAVED MEDIAN.
2. SEE SHEET 5 OF THIS SERIES FOR REINFORCEMENT DETAILS.
3. COORDINATE CONDUIT SIZE, LOCATION AND QUANTITY WITH ELECTRICAL PLANS. CONDUITS SHALL BE PLACED TO MISS REINFORCEMENT BARS. DO NOT CUT REINFORCEMENT BARS.



OVERHEAD SIGN STRUCTURE
BUTTERFLY TYPE
STRUCTURE DETAILS

STANDARD F14-02

Paul Kovacs
APPROVED CHIEF ENGINEER DATE 3-31-2014

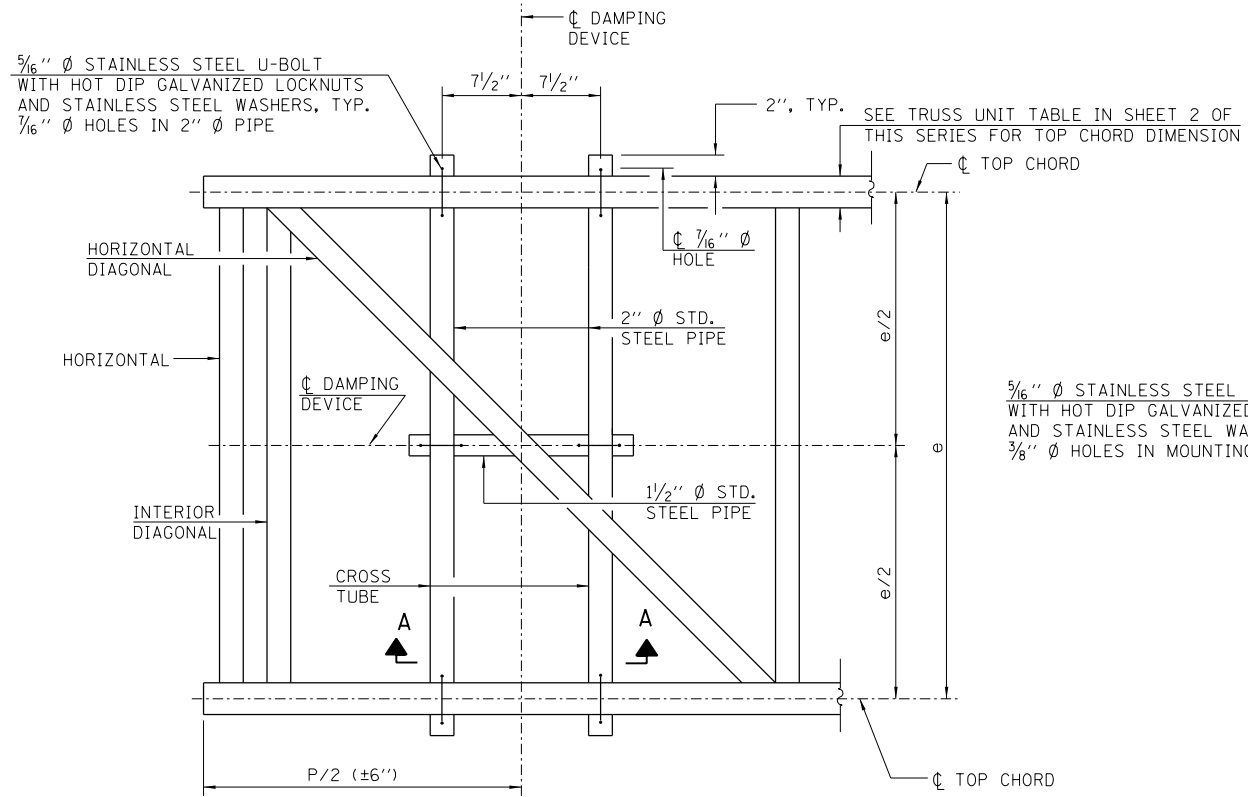

PLAN DETAIL

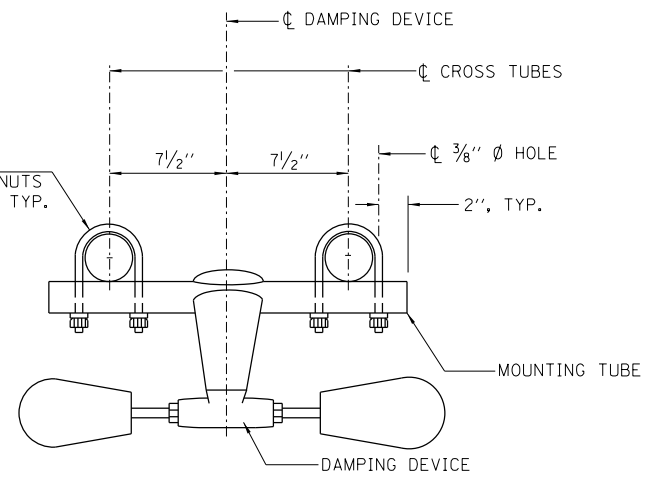

TRUSS DAMPING DEVICE CONNECTION DETAIL

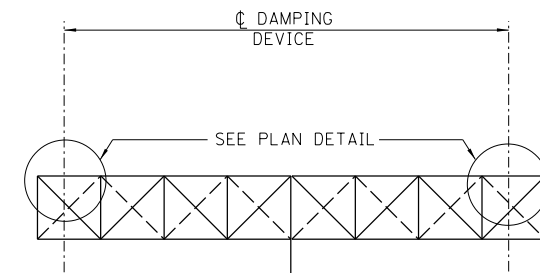

ELEVATION
STEEL BUTTERFLY SIGN STRUCTURE

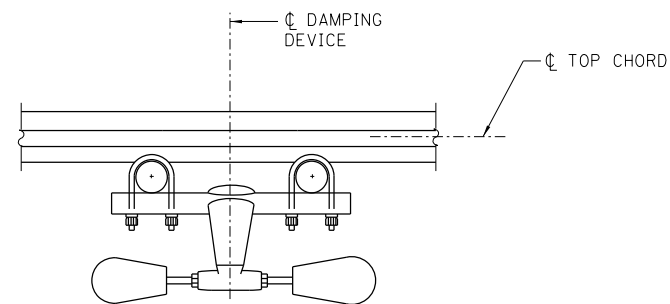

SECTION A-A

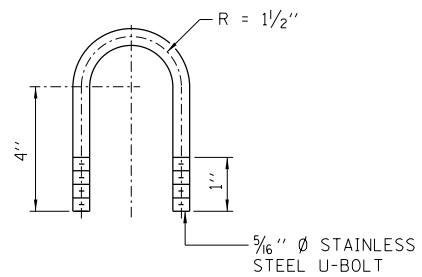

DAMPING DEVICE MOUNTING TUBE U-BOLT DETAIL (TYPICAL)

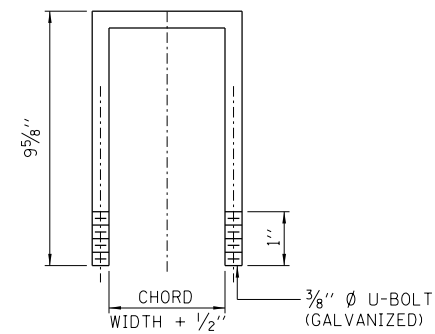

TOP CHORD TO CROSS TUBE U-BOLT DETAIL (TYPICAL)

NOTE:

DAMPER: ONE DAMPER PER TRUSS. (31 LBS. STOCKBRIDGE-TYPE 29" MINIMUM BETWEEN ENDS OF WEIGHTS) COST INCLUDED IN THE COST OF "OVERHEAD SIGN STRUCTURE, BUTTERFLY TYPE (STEEL)."



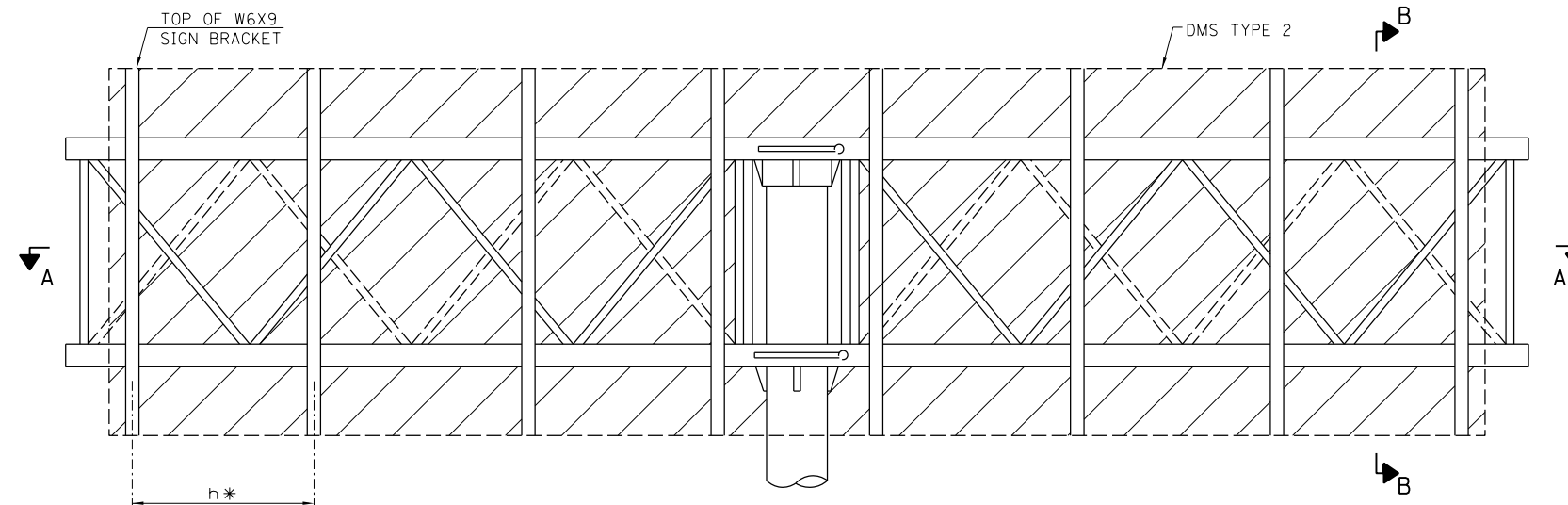

* BRACKET DIMENSIONS ARE NOMINAL AND WILL VARY BASED ON ACTUAL DMS TYPE 2 DIMENSIONS PLUS MANUFACTURER'S MOUNTING DEVICES.

TYPICAL FRONT ELEVATION

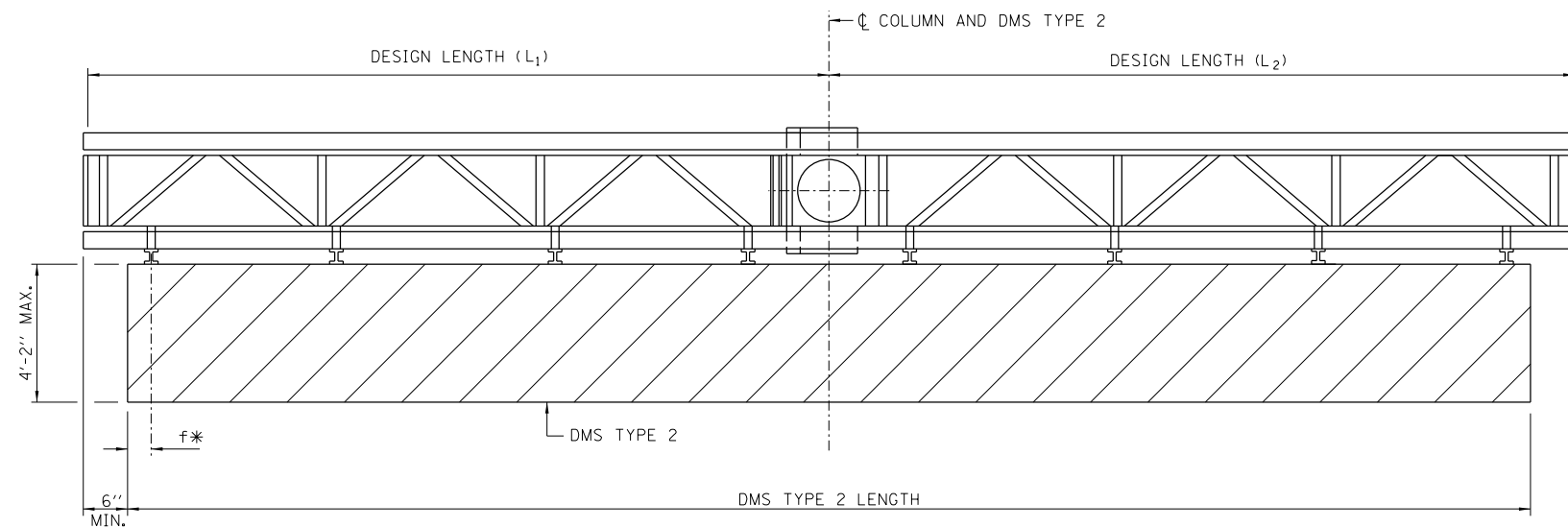

SECTION A-A

PLACE ALL SIGN BRACKETS AS CLOSE TO PANEL POINTS AS PRACTICAL.

(ROAD PLAN BENEATH TRUSS VARIES) BUTTERFLY MAY BE LOCATED IN SHOULDER AREA.

NOTES:

1. SPACE SIGN BRACKETS W6X9 FOR EFFICIENCY AND WITHIN LIMITS SHOWN:
2. $f = 12''$ MAXIMUM, $4''$ MINIMUM (END OF SIGN TO ϕ OF NEAREST BRACKET)
 $h = 6'-0''$ MAXIMUM (ϕ TO ϕ SIGN SUPPORT BRACKETS, W6X9)
3. MAXIMUM DMS TYPE 2 WEIGHT = 5000 LBS.
4. $4'-2''$ MAXIMUM DEPTH INCLUDES DEPTH OF DMS TYPE 2 PLUS CONNECTION TO W6X9.
5. DMS TYPE 2 MANUFACTURER MUST DESIGN AND SUPPLY HARDWARE FOR CONNECTION TO W6X9. BOLTS MUST BE STAINLESS STEEL OR HOT DIP GALVANIZED HIGH STRENGTH PER THE STANDARD SPECIFICATION.

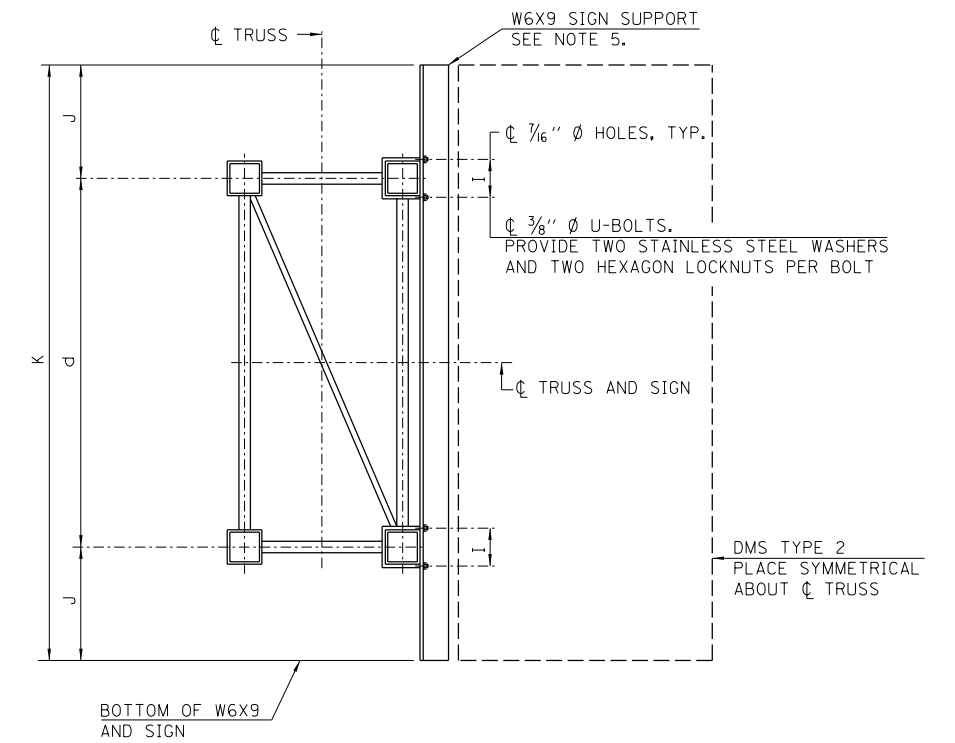

SECTION B-B

BRACKET TABLE

W6X9		
SIGN WIDTH		NUMBER OF BRACKETS REQUIRED
GREATER THAN	LESS THAN OR EQUAL TO	
	8'-0"	2
8'-0"	14'-0"	3
14'-0"	20'-0"	4
20'-0"	26'-0"	5
26'-0"	32'-0"	6



APPROVED: *Paul Kovacs* CHIEF ENGINEER DATE 3-31-2014

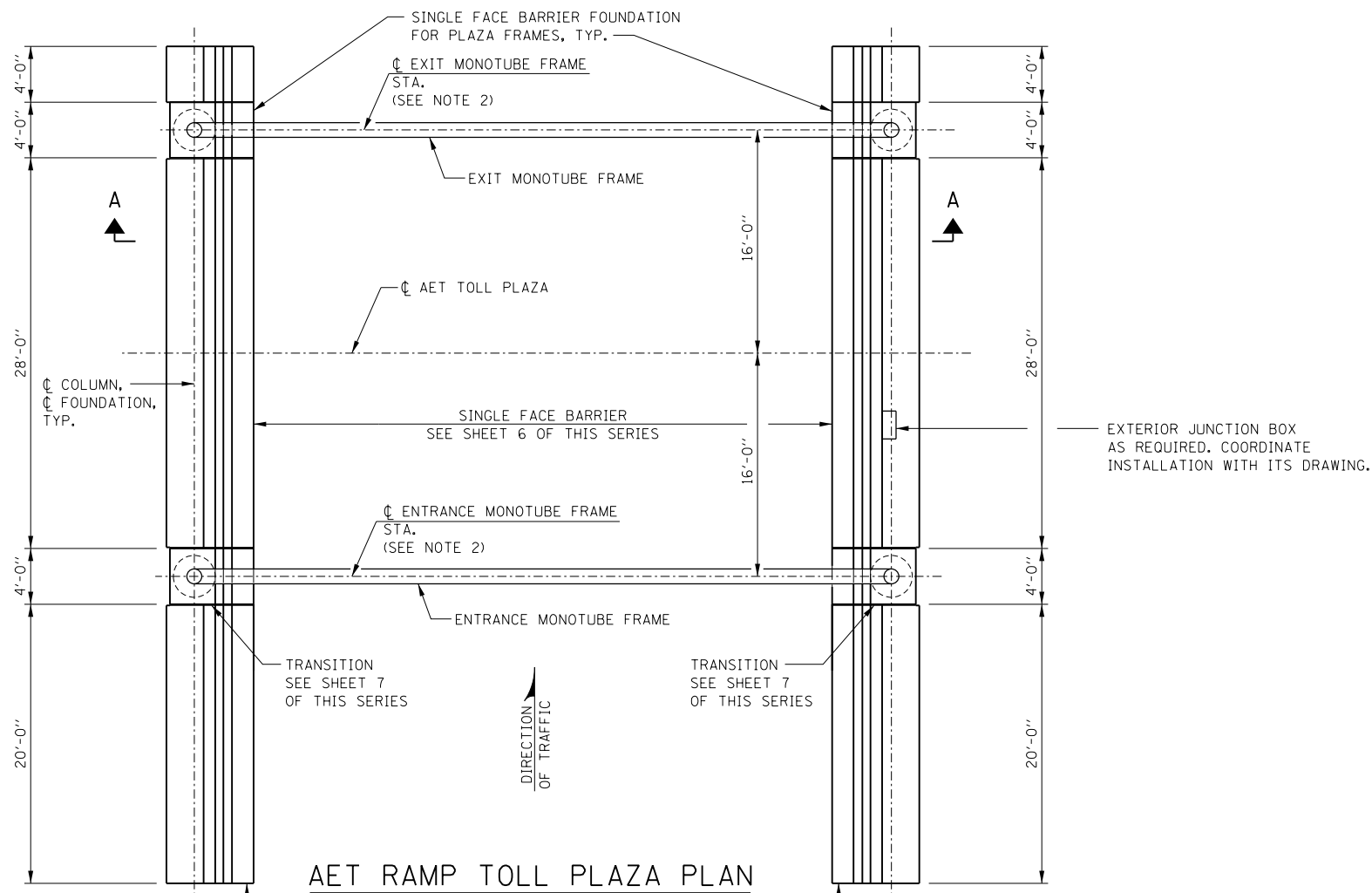

SIGN TABLE

SIGN	MAXIMUM AREA	MAXIMUM LENGTH
PLAZA SIGN	24 S.F.	8'-0"
I-PASS ONLY SIGN	20 S.F.	4'-0"

NOTE:

1. SEE CONTRACT PLANS FOR SIGN SIZE AND LOCATION.
2. PROVIDE ENTRANCE AND EXIT MONOTUBE FRAME STATIONS IN CONTRACT PLANS.

PROVIDE ATTENUATOR, BARRIER WALL OR GUARDRAIL TERMINAL AS SHOWN ON PLANS

PROVIDE ATTENUATOR, BARRIER WALL OR GUARDRAIL TERMINAL AS SHOWN ON PLANS

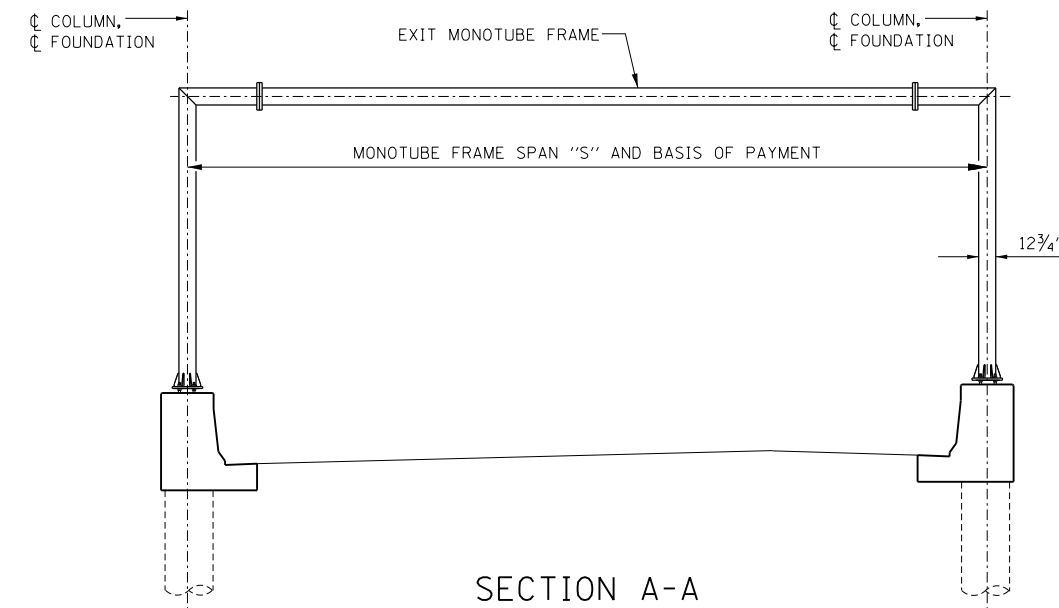
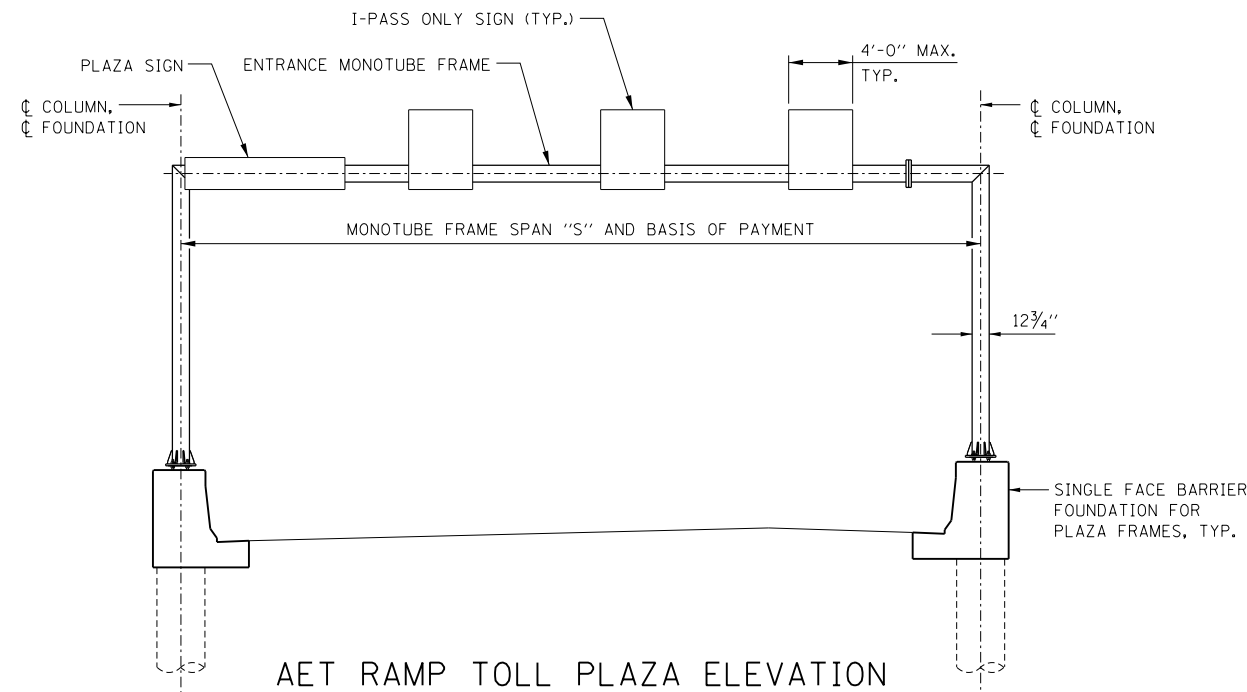

OVERHEAD SIGN STRUCTURE
MONOTUBE TYPE (STEEL)
STRUCTURE DETAILS
FOR AET RAMP
STANDARD F15-01

DATE	REVISIONS
3-31-2016	REVISED FOUNDATION NOTE

APPROVED *Paul Kovacs* CHIEF ENGINEER DATE 10-14-2014

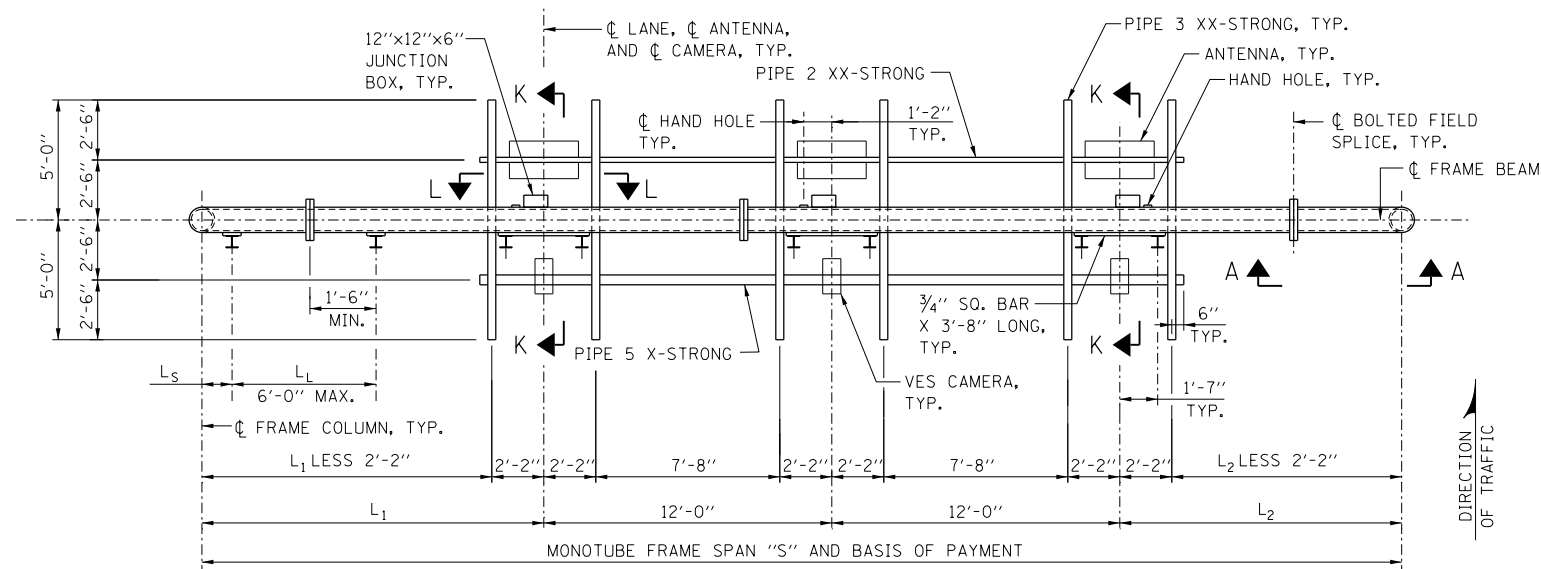

AET RAMP ENTRANCE MONOTUBE PLAN

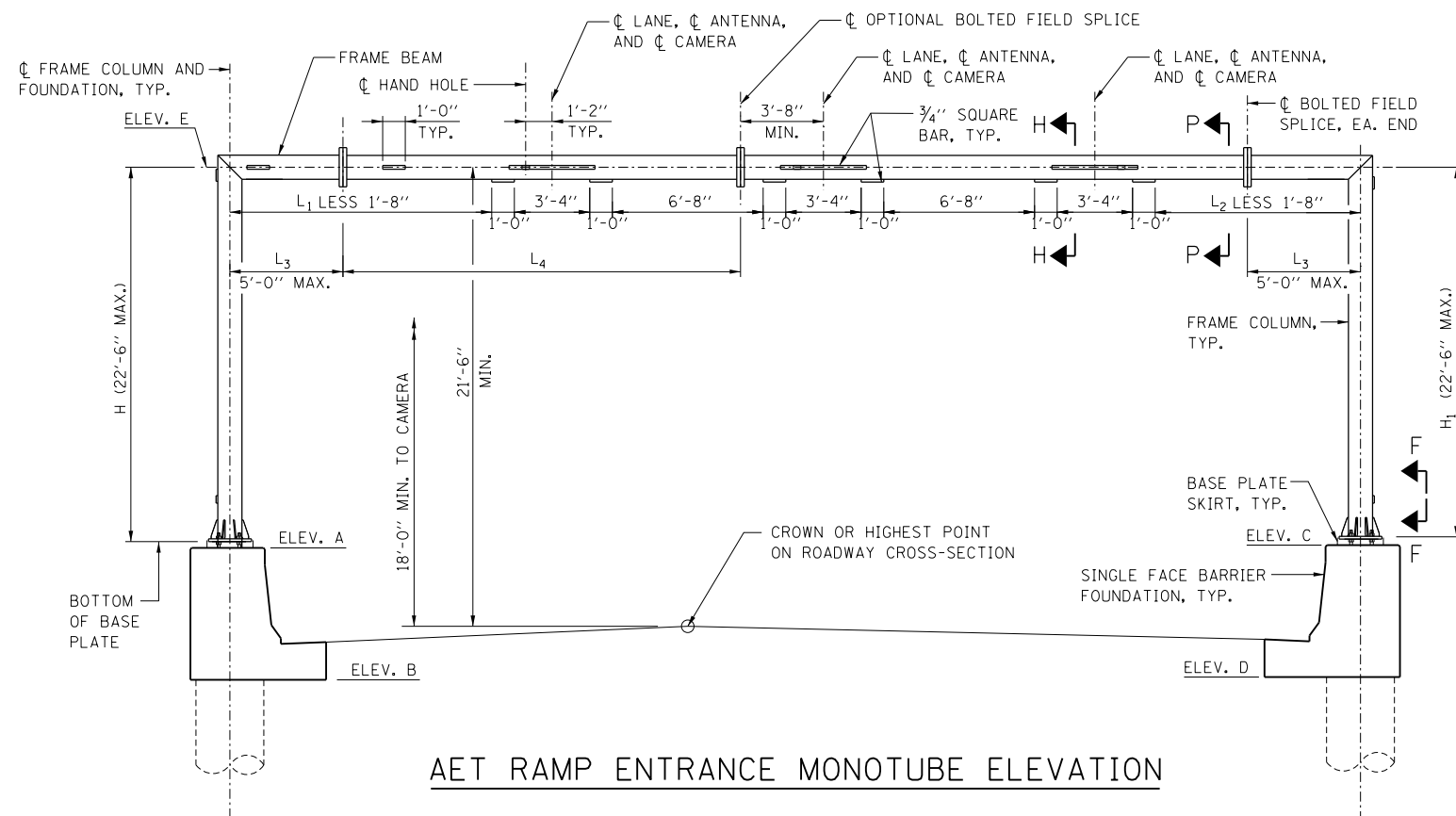

AET RAMP ENTRANCE MONOTUBE ELEVATION

NOTES:

1. FOUNDATIONS FOR MONOTUBE FRAMES ARE SHOWN ON SHEET 6 OF THIS SERIES.
2. SEE SHEET 5 OF THIS SERIES FOR SECTIONS A-A, G-G, H-H, K-K, VIEW F-F AND BASE PLATE SKIRT.
3. SEE SHEET 4 OF THIS SERIES FOR SECTION P-P.
4. PROVIDE CAMBER AT MIDSPAN OF STRUCTURE.
5. LOCATE OPTIONAL BOLTED FIELD SPLICE NEAR MIDSPAN.
6. WORK THIS SHEET WITH, OVERHEAD SIGN STRUCTURE ENTRANCE MONOTUBE TYPE (STEEL) AET RAMP SUMMARY AND TOTAL BILL OF MATERIAL SHEET.

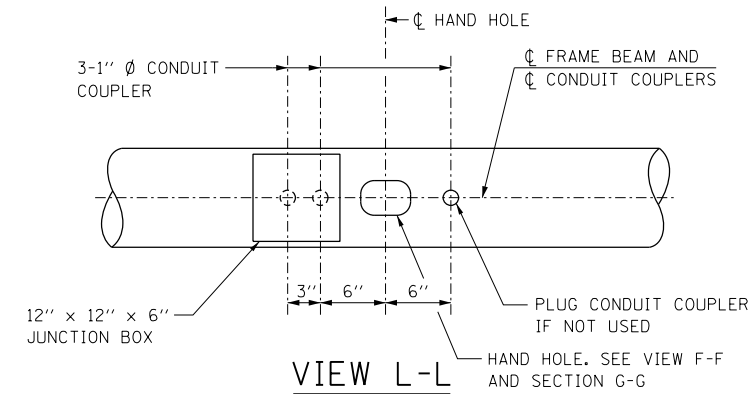

VIEW L-L

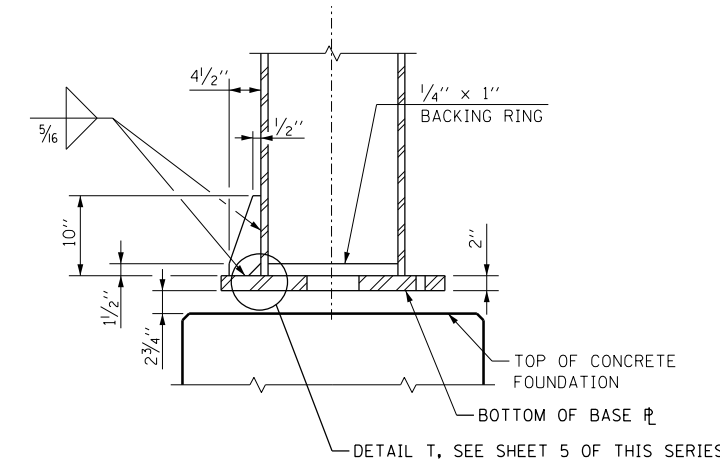

SECTION S-S

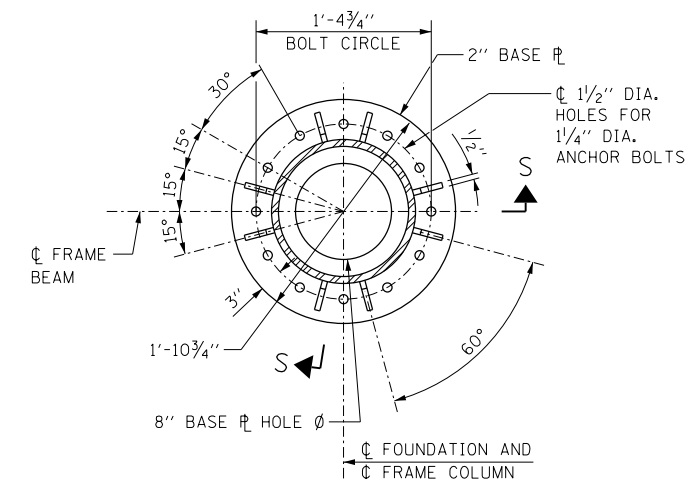

**BASE PLATE PLAN
ENTRANCE AND EXIT MONOTUBE**

ENTRANCE MONOTUBE FRAME TABLE

SPAN "S"	FRAME COLUMN	FRAME BEAM	CAMBER
50' MAX.	HSS 12.75x0.500	HSS 12.75x0.500	1 3/4"

SEE ILLINOIS TOLLWAY STANDARD DRAWING F13 FOR SPANS GREATER THAN 50'.



OVERHEAD SIGN STRUCTURE
MONOTUBE TYPE (STEEL)
STRUCTURE DETAILS
FOR AET RAMP

STANDARD F15-01

APPROVED: *Paul Kovacs* CHIEF ENGINEER DATE 10-14-2014

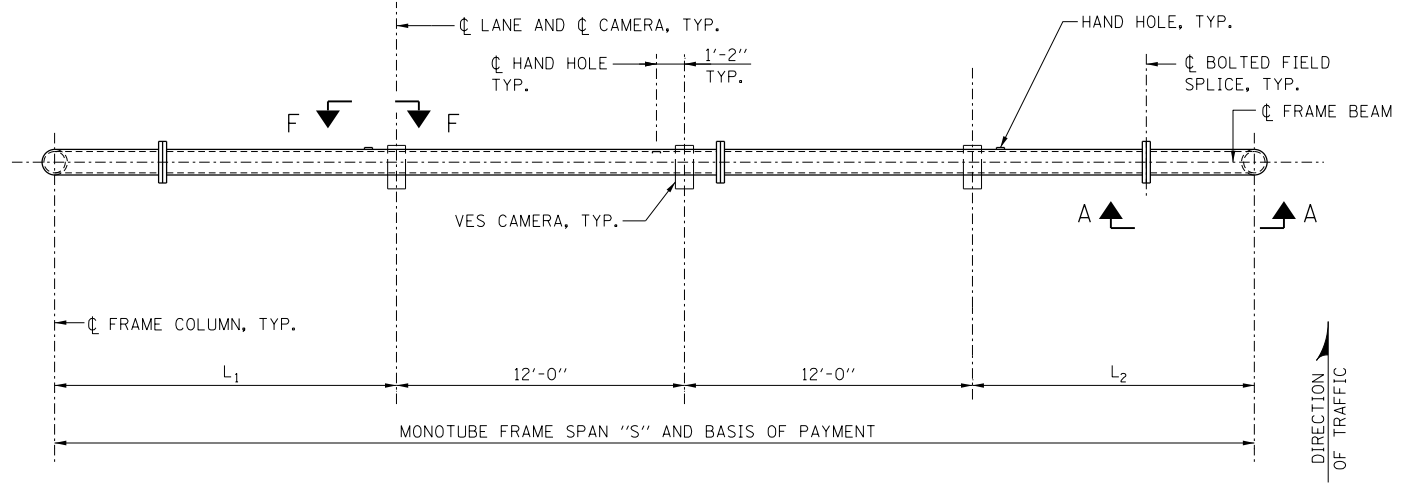

AET RAMP EXIT MONOTUBE PLAN

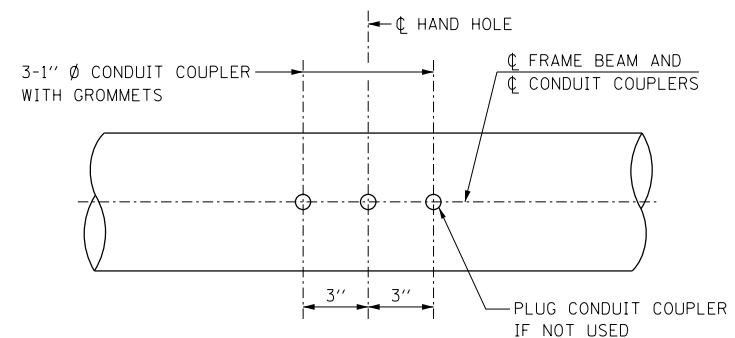

VIEW N-N (CONDUIT COUPLER DETAIL)

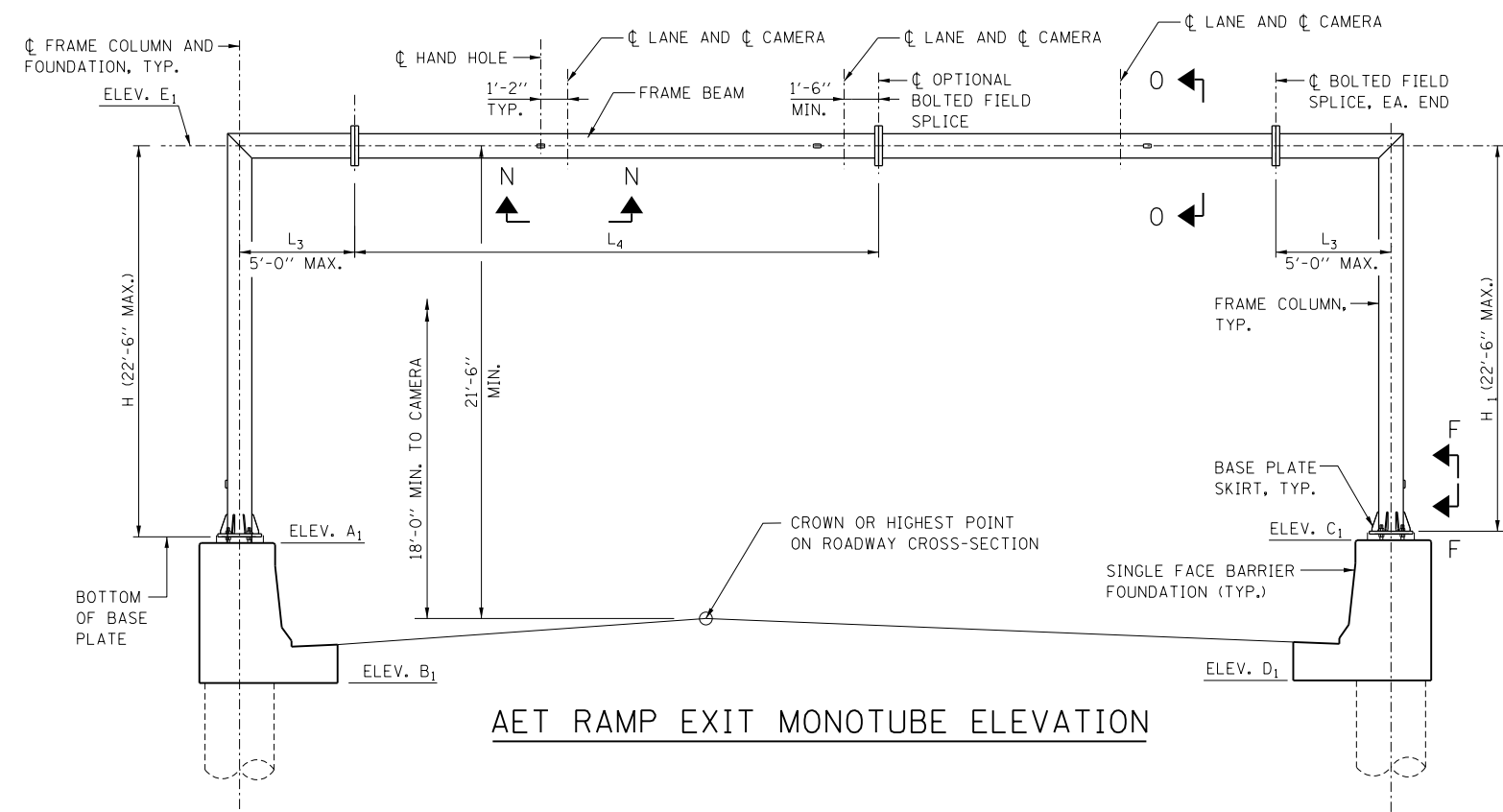

AET RAMP EXIT MONOTUBE ELEVATION

EXIT MONOTUBE FRAME TABLE

SPAN "S"	FRAME COLUMN	FRAME BEAM	CAMBER
50' MAX.	HSS 12.75x0.500	HSS 12.75x0.500	1 3/4"

SEE STANDARD F13 FOR SPANS GREATER THAN 50'.

NOTES:

1. SEE SHEET 2 OF THIS SERIES FOR SECTION S-S, BASE PLAN AND ADDITIONAL NOTES.
2. SEE SHEET 4 OF THIS SERIES FOR SECTION O-O.
3. SEE SHEET 5 OF THIS SERIES FOR SECTIONS A-A AND G-G, AND BASE PLATE SKIRT.
4. WORK THIS SHEET WITH, OVERHEAD SIGN STRUCTURE EXIT MONOTUBE TYPE (STEEL) AET RAMP SUMMARY AND TOTAL BILL OF MATERIAL SHEET.

APPROVED *Paul Kovacs* CHIEF ENGINEER DATE 10-14-2014

OVERHEAD SIGN STRUCTURE
MONOTUBE TYPE (STEEL)
STRUCTURE DETAILS
FOR AET RAMP
STANDARD F15-01

GENERAL NOTES:

1. AFTER ADJUSTMENTS TO LEVEL FRAME BEAM AND ENSURE ADEQUATE VERTICAL CLEARANCE, TIGHTEN ALL TOP AND LEVELING NUTS AGAINST THE BASE PLATE WITH A MINIMUM TORQUE OF 200 LB.-FT. THEN PLACE STAINLESS STEEL MESH AROUND THE PERIMETER OF THE BASE PLATE. SECURE TO BASE PLATE WITH STAINLESS STEEL BANDING.
2. REINFORCEMENT BARS DESIGNATED "(E)" SHALL BE EPOXY COATED.

STRUCTURAL STEEL:

1. MATERIAL FOR THE MONOTUBE FRAME SHALL CONFORM TO THE REQUIREMENTS OF ASTM A500 GRADE B. BASE PLATE AND STIFFENER PLATE SHALL CONFORM TO ASTM A709 GRADE 50. OTHER STRUCTURAL STEEL SHAPES AND PLATES SHALL CONFORM TO THE REQUIREMENTS OF ASTM A36, UNLESS NOTED OTHERWISE.
2. PIPES SHALL CONFORM TO THE REQUIREMENTS OF ASTM A53 GRADE B.
3. ANCHOR BOLTS SHALL CONFORM TO THE REQUIREMENTS OF ASTM F1554 (AASHTO M314) GRADE 55, WITH A MINIMUM TENSILE STRENGTH OF 75,000 PSI. THEY SHALL BE GALVANIZED IN ACCORDANCE WITH ASTM A153 (AASHTO M232). SEE SHEET 6 OF THIS SERIES FOR GALVANIZED LENGTH.
4. U-BOLTS SHALL BE STAINLESS STEEL. PROVIDE STAINLESS STEEL WASHERS AND NUTS FOR U-BOLTS.
5. BOLTS (EXCLUDING ANCHOR BOLTS AND U-BOLTS) SHALL BE HIGH STRENGTH STEEL BOLTS.
6. TUBES FOR MONOTUBE FRAME, PIPES, STRUCTURAL STEEL SHAPES AND PLATES SHALL BE GALVANIZED IN ACCORDANCE WITH ASTM A123 AFTER FABRICATION.
7. THE MONOTUBE FRAME BEAM, COLUMNS, BASE PLATE MATERIAL, AND SPLICES ARE CONSIDERED TENSION MEMBERS AND SHALL CONFORM TO THE IMPACT TESTING REQUIREMENT, ZONE 2.

DESIGN LOADING:

WIND LOAD CRITERIA

SIGN PANEL	35 P.S.F.
COLUMN/BEAM	35 P.S.F.

EQUIPMENT LOADS:

CAMERA ASSEMBLY	8 LB.
ANTENNA	20 LB.

DESIGN STRESSES FOR REINFORCED CONCRETE:

f'c = COMPRESSIVE STRENGTH OF CONCRETE (CLASS SI)	= 3,500 P.S.I.
f'c = COMPRESSIVE STRENGTH OF CONCRETE (CLASS DS)	= 4,000 P.S.I.
fy = YIELD STRENGTH OF REINFORCEMENT BARS (GRADE 60)	= 60,000 P.S.I.

FOUNDATION:

MINIMUM UNCONFINED COMPRESSIVE STRENGTH, Qu FOR ALL LAYERS OF COHESIVE SOILS (CLAYS) SHALL BE 1.25 TON/SQ.FT. AT MONOTUBE FRAMES.

DESIGN SPECIFICATIONS:

1. STRUCTURE DESIGN MANUAL, DATED MARCH, 2014, WITH LATEST DESIGN BULLETINS.
2. AASHTO STANDARD SPECIFICATION FOR STRUCTURAL SUPPORTS FOR HIGHWAY SIGNS, LUMINAIRES AND TRAFFIC SIGNALS, 6TH EDITION.
3. AASHTO LRFD BRIDGE DESIGN SPECIFICATIONS, 6TH EDITION DATED FEBRUARY 2012.
4. ILLINOIS DEPARTMENT OF TRANSPORTATION BRIDGE MANUAL, JANUARY 2012

CONSTRUCTION SPECIFICATIONS:

1. ILLINOIS TOLLWAY SUPPLEMENTAL SPECIFICATIONS TO THE ILLINOIS DEPARTMENT OF TRANSPORTATION STANDARD SPECIFICATIONS FOR ROAD AND BRIDGE CONSTRUCTION, LATEST EDITION.
2. ILLINOIS DEPARTMENT OF TRANSPORTATION STANDARD SPECIFICATIONS FOR ROAD AND BRIDGE CONSTRUCTION, LATEST EDITION.

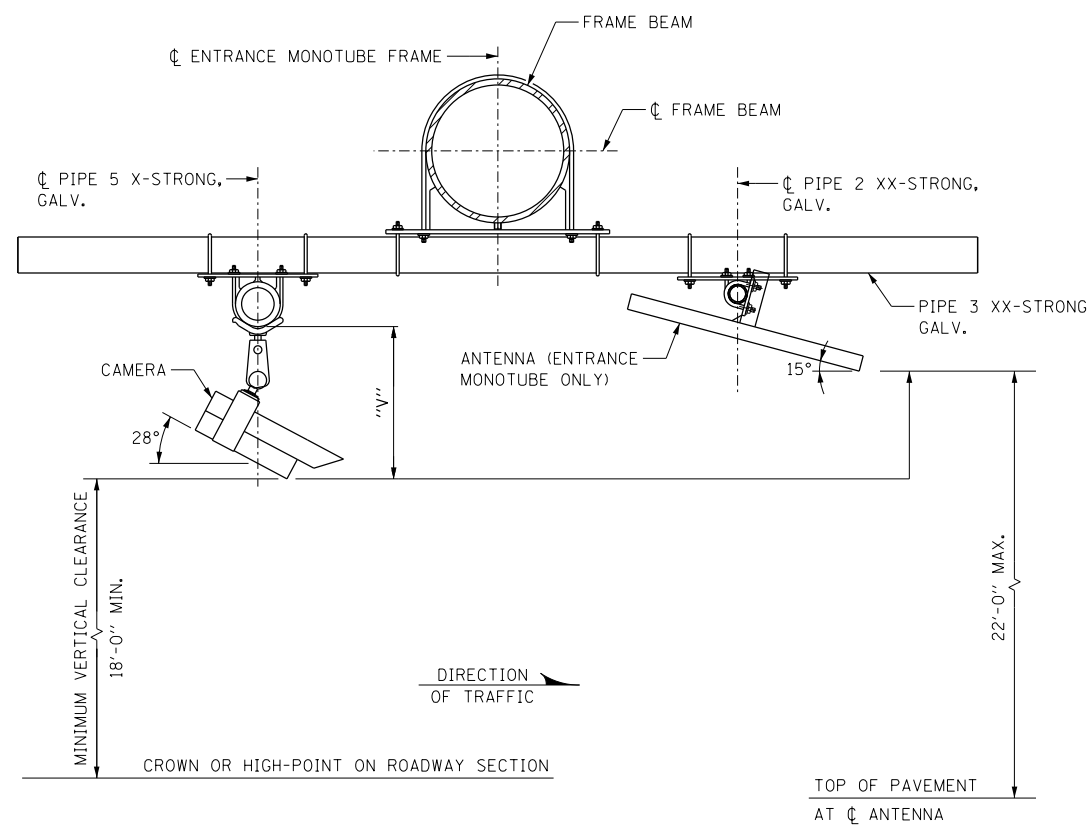

SECTION P-P

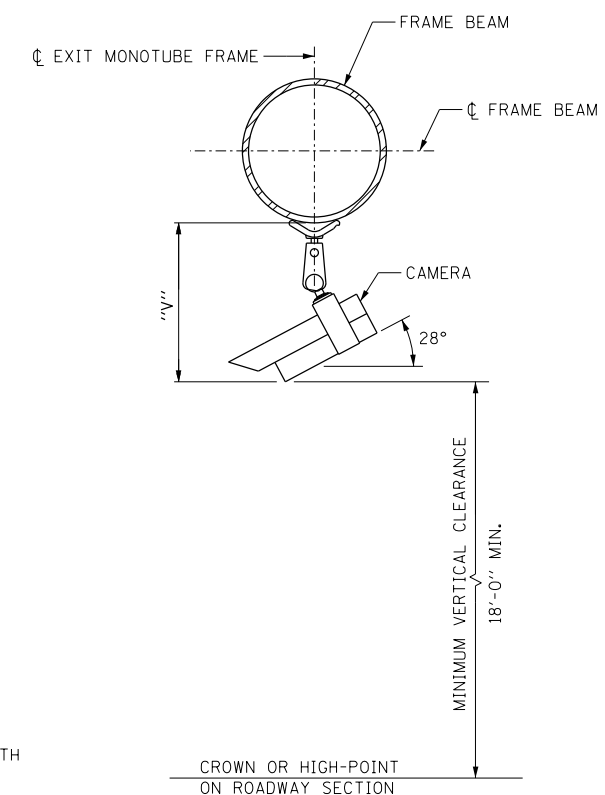

SECTION 0-0

NOTE:
VERIFY DIMENSION "V" WITH CAMERA MANUFACTURER.

APPROVED: *Paul Kovacs* CHIEF ENGINEER DATE 10-14-2014



OVERHEAD SIGN STRUCTURE
MONOTUBE TYPE (STEEL)
STRUCTURE DETAILS
FOR AET RAMP

STANDARD F15-01

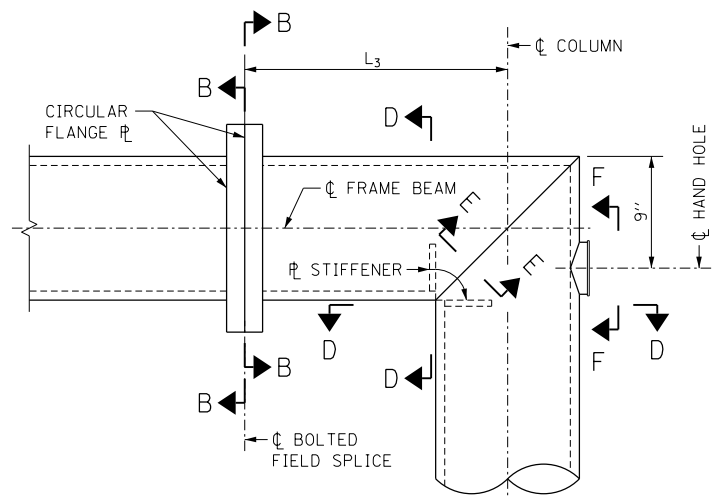

SECTION A-A

(SEE SHEETS 2 AND 3 OF THIS SERIES FOR LOCATION)

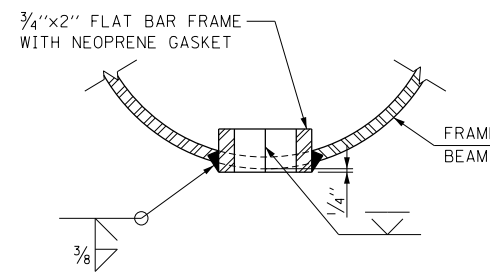

SECTION G-G

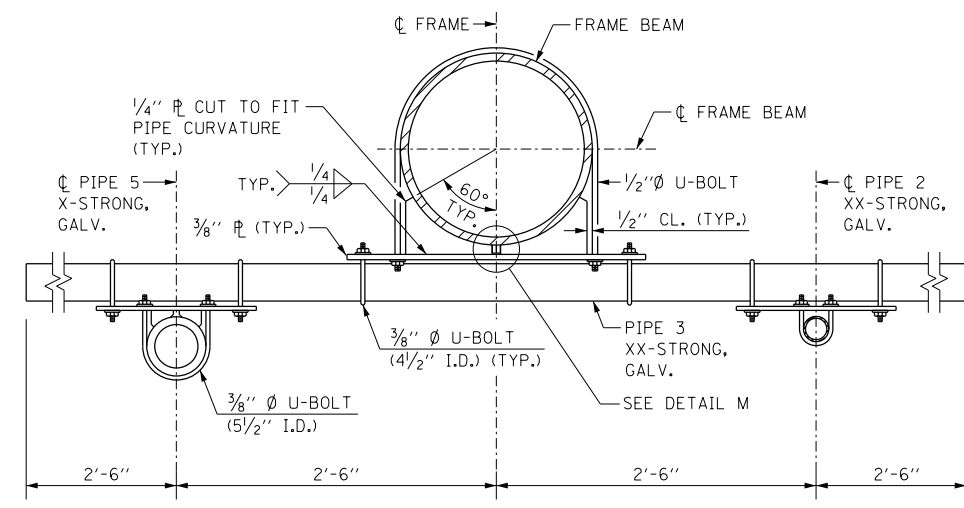

SECTION K-K

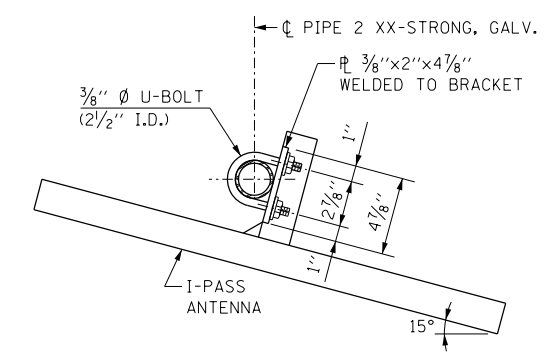

ANTENNA HANGER

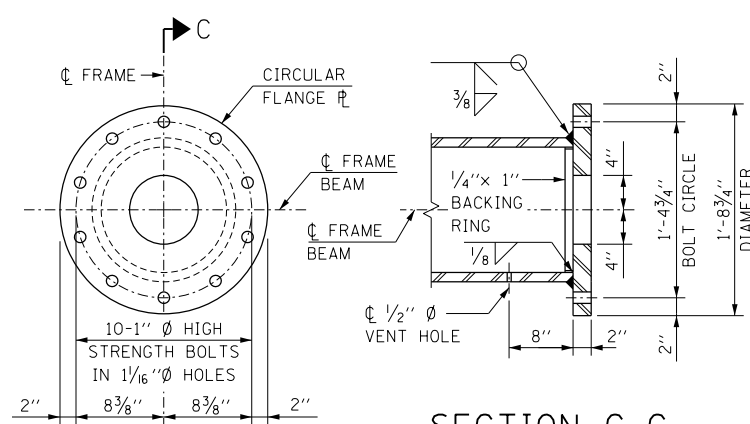

SECTION C-C

SECTION B-B

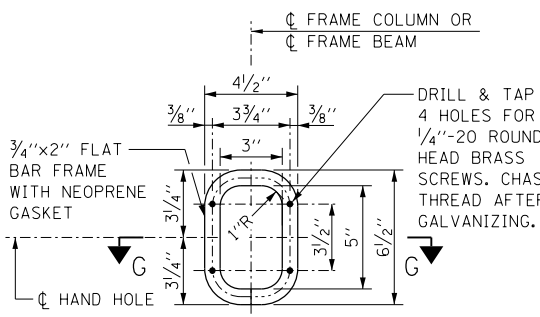

VIEW F-F

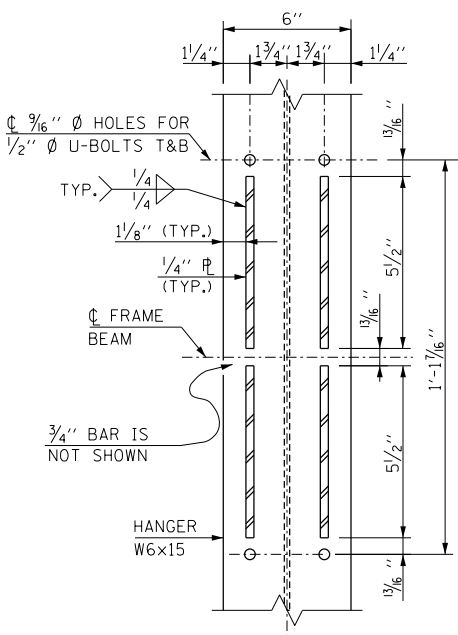

SECTION J-J

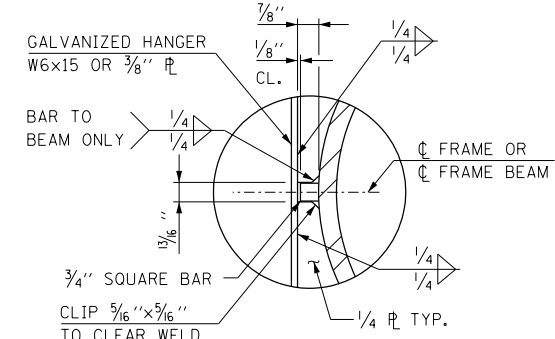

DETAIL M

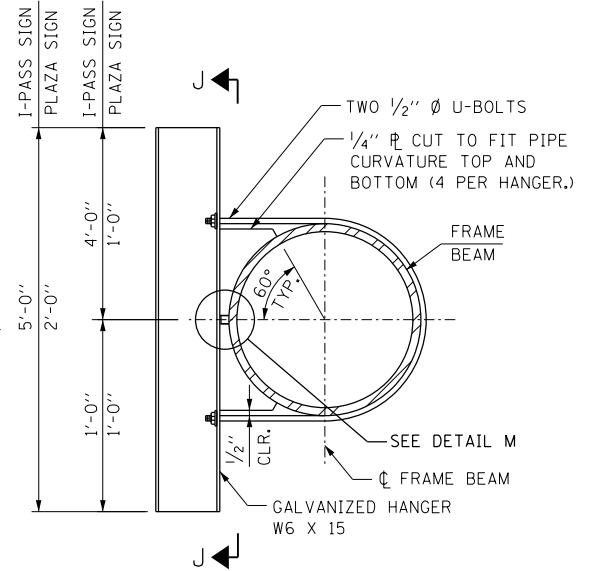

SECTION H-H (SIGN HANGER)

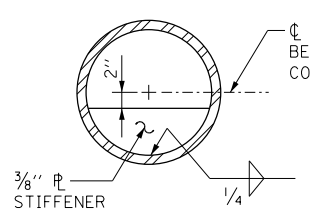

SECTION D-D

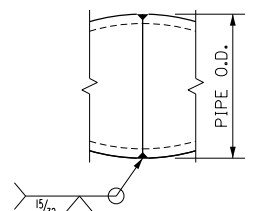

SECTION E-E

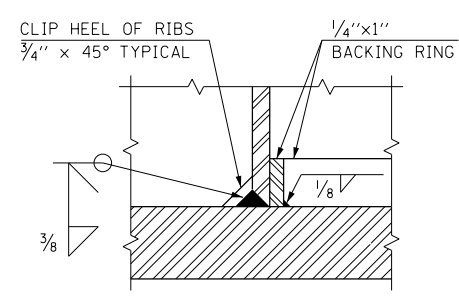

DETAIL T

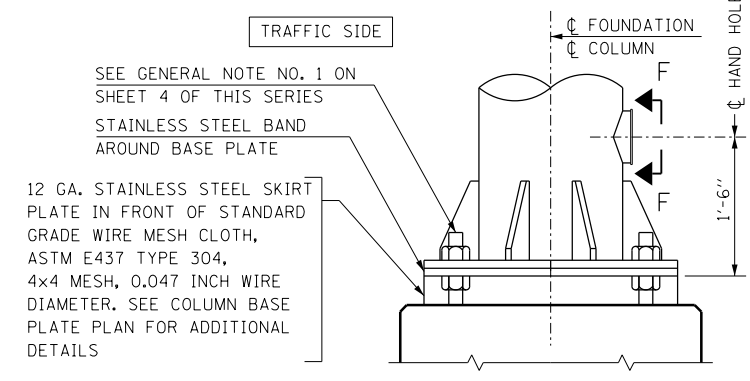

COLUMN BASE

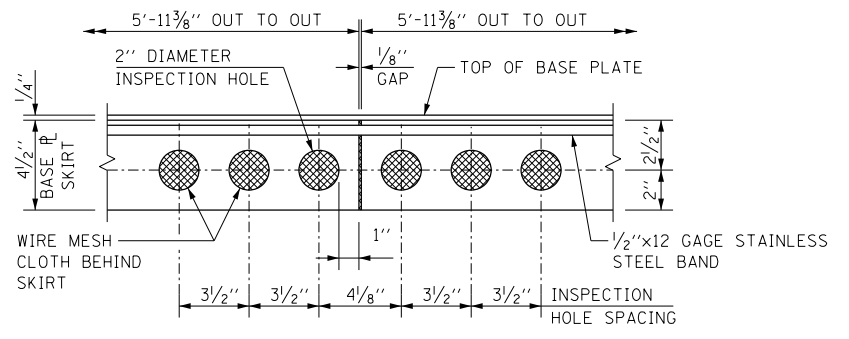

VIEW R-R (BASE PLATE SKIRT)

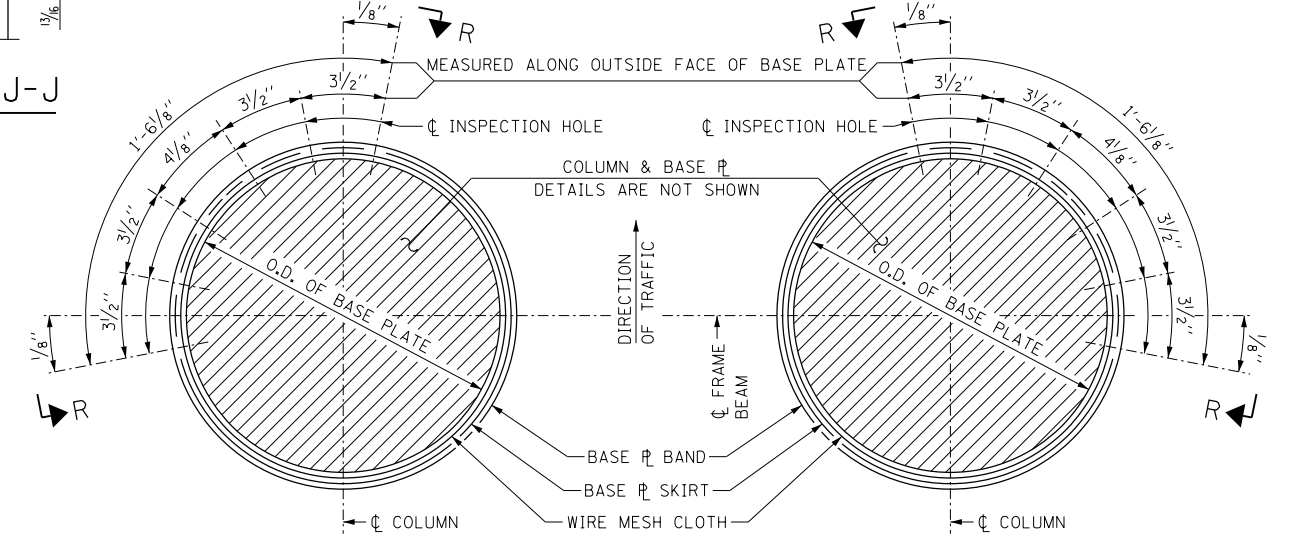

LEFT BASE PLATE

COLUMN BASE PLATE PLAN

RIGHT BASE PLATE

SHEET 5 OF 7

NOTE:

SEE SHEET 2 OF THIS SERIES FOR BASE PLATE OUTSIDE DIAMETER.

APPROVED *Paul Kovacs* CHIEF ENGINEER DATE 10-14-2014

Illinois Tollway

OVERHEAD SIGN STRUCTURE
MONOTUBE TYPE (STEEL)
STRUCTURE DETAILS
FOR AET RAMP
STANDARD F15-01

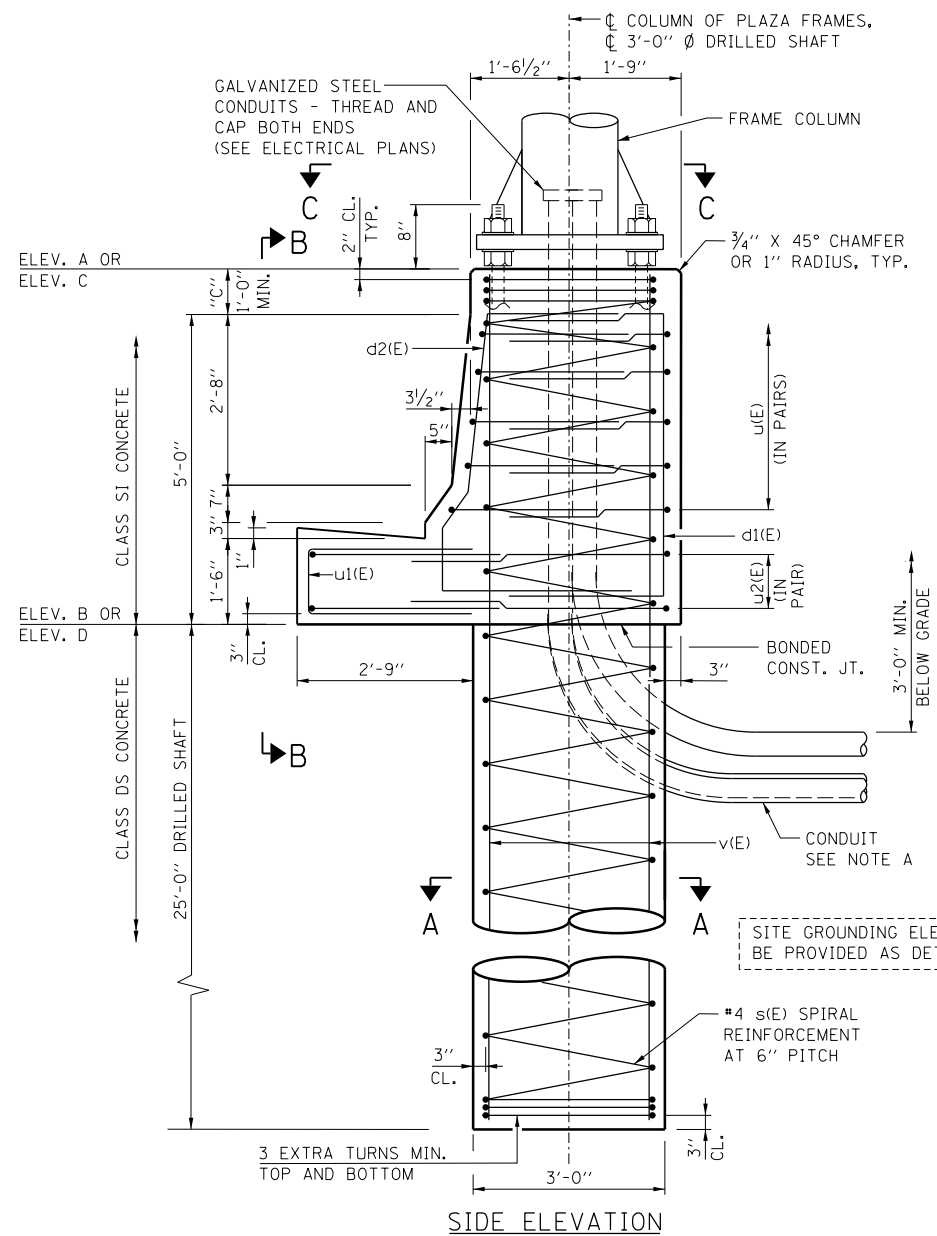

SIDE ELEVATION

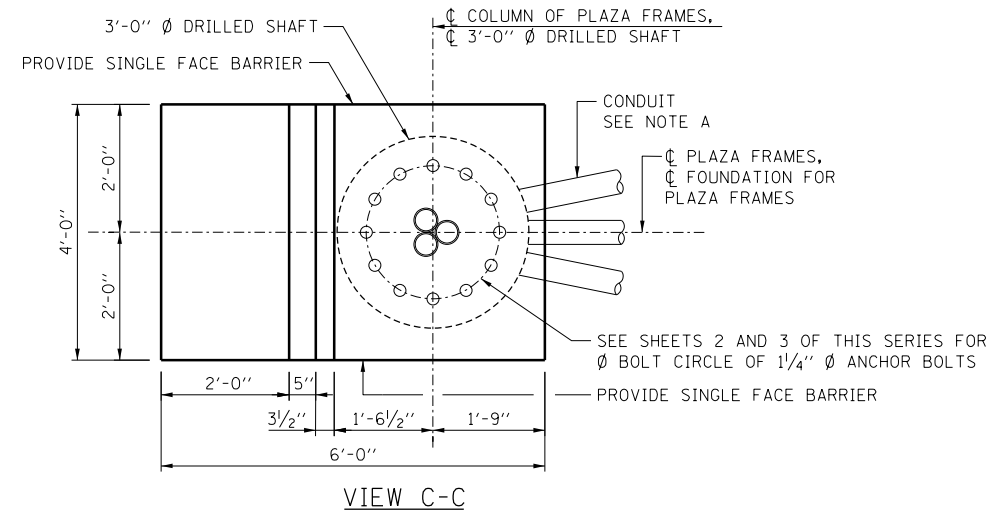

VIEW C-C

SINGLE FACE BARRIER FOUNDATION FOR PLAZA FRAMES

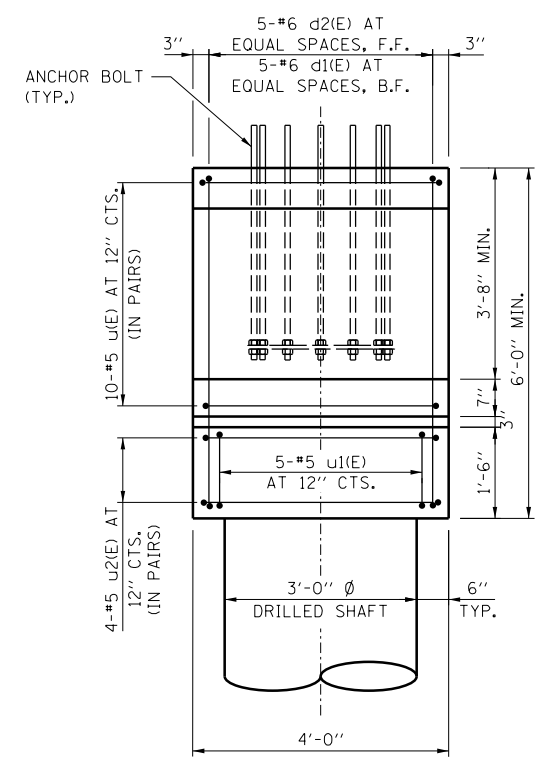

VIEW B-B

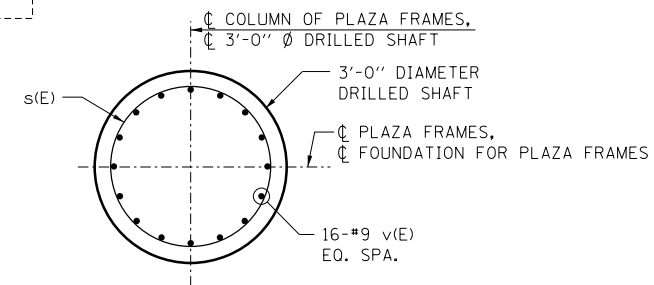

SECTION A-A

- NOTE A:**
- COORDINATE CONDUIT SIZE, LOCATION AND QUANTITY WITH ELECTRICAL PLANS. PROVIDE CONDUIT COUPLERS AS REQUIRED.
 - CONDUITS SHALL BE PLACED TO MISS REINFORCEMENT. CUTTING OF REINFORCEMENT SHALL NOT BE ALLOWED.
 - COST OF CONDUIT INCLUDED IN FOUNDATION FOR OVERHEAD SIGN STRUCTURE, RAMP MONOTUBE TYPE.
 - PROTECTIVE COAT SHALL BE APPLIED TO THE TRAFFIC AND TOP FACES OF THE BARRIER AND TOP OF GUTTER

FOUNDATION NOTE:
THE FOUNDATION DETAILS SHOWN ARE BASED ON THE PRESENCE OF MOSTLY COMMON COHESIVE SOIL CONDITIONS (SILTY OR SANDY CLAY), WITH AN AVERAGE UNCONFINED COMPRESSIVE STRENGTH (QU) > 1.25 TON/SQ. FT. WHICH MUST BE DETERMINED BY PREVIOUS SOIL INVESTIGATIONS AT THE JOBSITE. WHEN OTHER CONDITIONS ARE INDICATED, THE BORING DATA SHALL BE INCLUDED IN THE PLANS AND THE FOUNDATION DIMENSIONS SHOWN SHALL BE THE RESULT OF SITE SPECIFIC DESIGNS. IF CONDITIONS ENCOUNTERED IN THE FIELD ARE DIFFERENT THAN THOSE INDICATED, THE CONTRACTOR SHALL NOTIFY THE ENGINEER TO DETERMINE IF THE FOUNDATION DIMENSIONS NEED TO BE MODIFIED.

LEGEND:
F.F. - FRONT FACE
B.F. - BACK FACE
CTS. - CENTERS

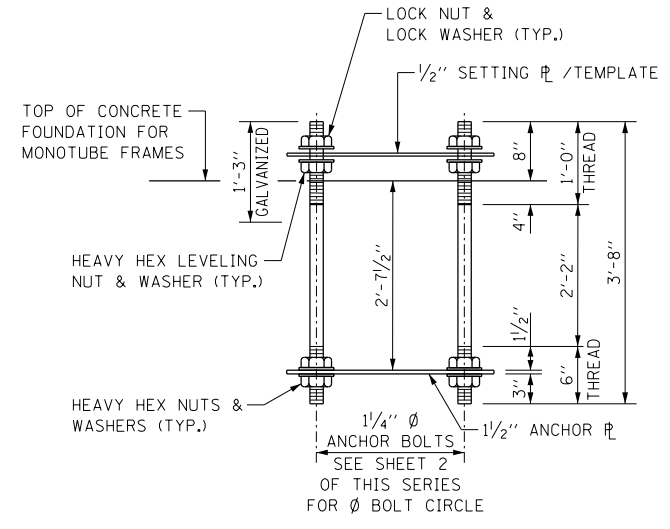

ANCHOR BOLT ASSEMBLY

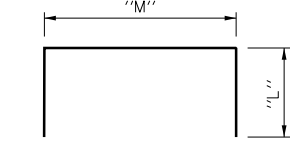

BAR	"L"	"M"	
d1(E)	2'-9"	5'-7"	**
u(E)	2'-9"	3'-8"	
u1(E)	3'-3"	1'-1"	
u2(E)	3'-10"	3'-8"	

BARS d1(E), u(E), u1(E) AND u2(E)

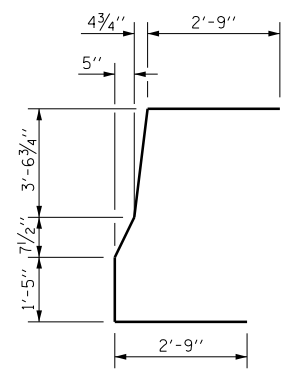

BAR d2(E)

FRAME COLUMN	ANCHOR BOLT
HSS 12.75x0.500	12

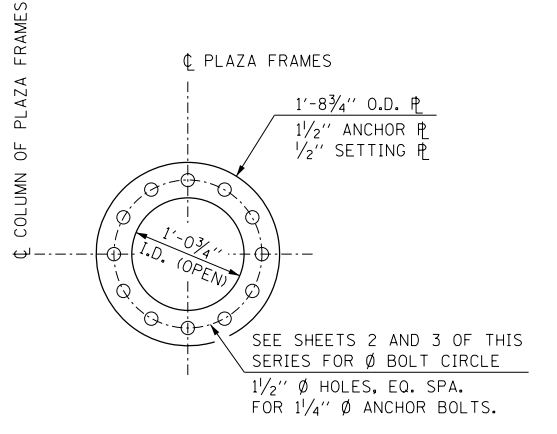

ANCHOR PL / SETTING PL

BAR LIST-ONE FOUNDATION

BAR	NO.	SIZE	LENGTH	SHAPE	
**	d1(E)	5	#6	11'-1"	□
**	d2(E)	5	#6	11'-3"	□
*	s(E)	1	#4	30'-7"	WWW
**	v(E)	16	#9	30'-7"	—
	u(E)	10	#5	9'-2"	□
	u1(E)	5	#5	7'-7"	□
	u2(E)	4	#5	11'-4"	□

- * THE LENGTH OF SPIRAL SHOWN IS THE HEIGHT OF SPIRAL, COMPUTED USING "C" = 1'-0". ADJUST LENGTH ACCORDINGLY IF "C" IS GREATER THAN 1'-0".
- ** BAR LENGTH IS COMPUTED USING "C" = 1'-0". ADJUST BAR LENGTH ACCORDINGLY IF "C" IS GREATER THAN 1'-0".

ESTIMATED QUANTITY

ITEM	UNIT	SINGLE FACE BARRIER FDN.
CLASS SI CONCRETE	CU. YD.	3.7
CLASS DS CONCRETE	CU. YD.	6.6
REINFORCEMENT BARS, EPOXY COAT	POUND	2,360
PROTECTIVE COAT	SQ. YD.	5.0

NOTE:
QUANTITIES FOR SINGLE FACE BARRIER FOUNDATION ARE DETERMINED USING "C" = 1'-0". IF DIMENSION "C" IS GREATER THAN 1'-0", ADJUST QUANTITIES ACCORDINGLY.

APPROVED: *Paul Kovacs* CHIEF ENGINEER DATE 10-14-2014

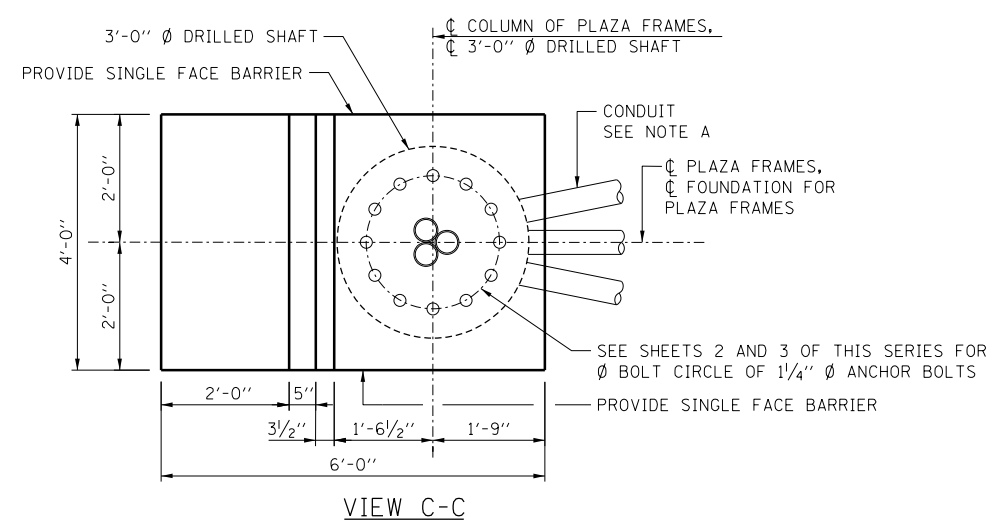
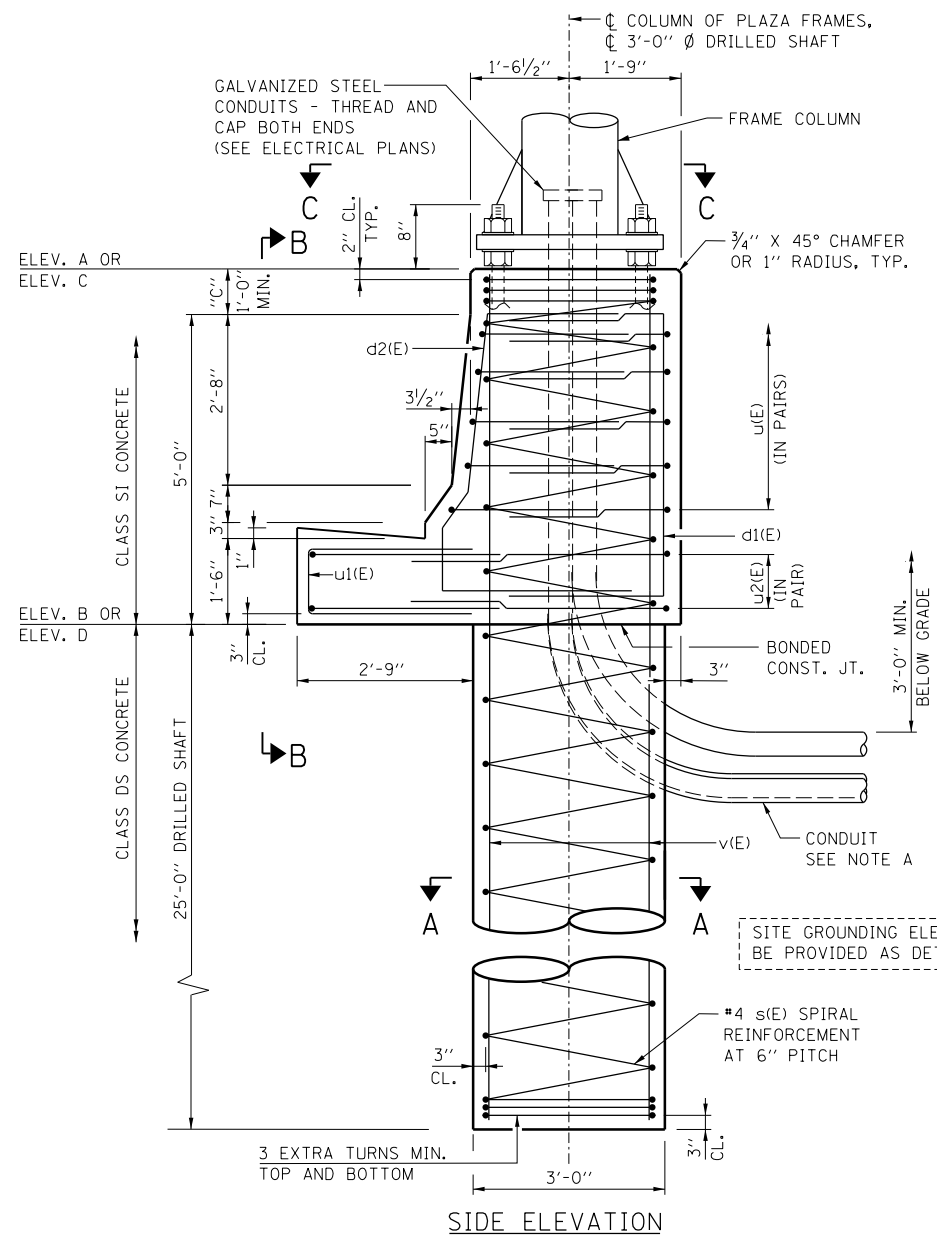

SINGLE FACE BARRIER FOUNDATION FOR PLAZA FRAMES

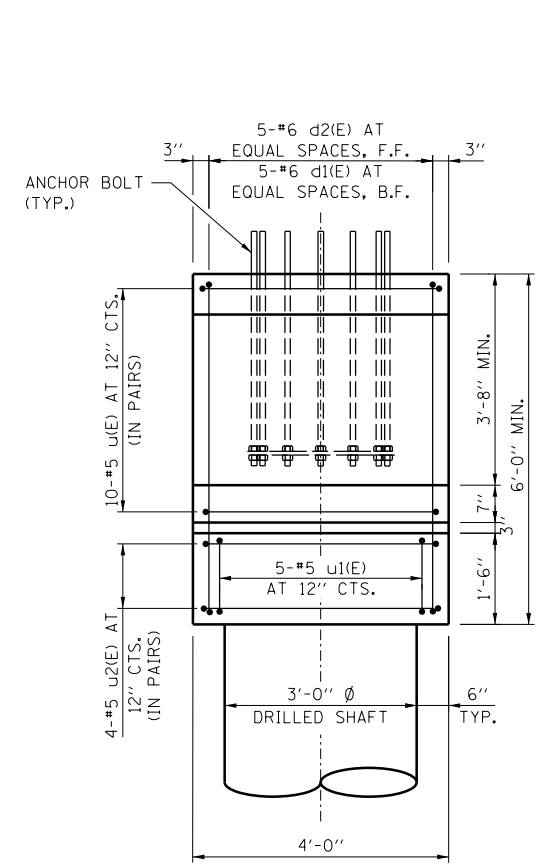

VIEW B-B

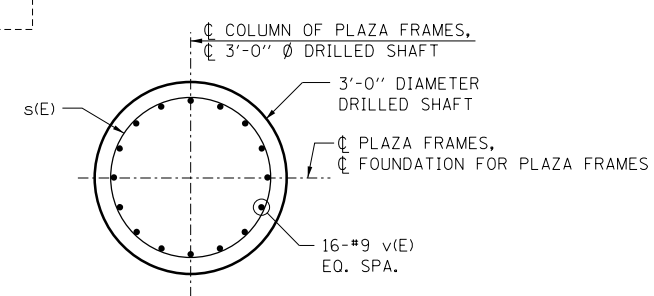

SECTION A-A

- NOTE A:**
- COORDINATE CONDUIT SIZE, LOCATION AND QUANTITY WITH ELECTRICAL PLANS. PROVIDE CONDUIT COUPLERS AS REQUIRED.
 - CONDUITS SHALL BE PLACED TO MISS REINFORCEMENT. CUTTING OF REINFORCEMENT SHALL NOT BE ALLOWED.
 - COST OF CONDUIT INCLUDED IN FOUNDATION FOR OVERHEAD SIGN STRUCTURE, RAMP MONOTUBE TYPE.
 - PROTECTIVE COAT SHALL BE APPLIED TO THE TRAFFIC AND TOP FACES OF THE BARRIER AND TOP OF GUTTER

FOUNDATION NOTE:
 THE FOUNDATION DETAILS SHOWN ARE BASED ON THE PRESENCE OF MOSTLY COMMON COHESIVE SOIL CONDITIONS (SILTY OR SANDY CLAY), WITH AN AVERAGE UNCONFINED COMPRESSIVE STRENGTH (QU) > 1.25 TON/SQ. FT. WHICH MUST BE DETERMINED BY PREVIOUS SOIL INVESTIGATIONS AT THE JOBSITE. WHEN OTHER CONDITIONS ARE INDICATED, THE BORING DATA SHALL BE INCLUDED IN THE PLANS AND THE FOUNDATION DIMENSIONS SHOWN SHALL BE THE RESULT OF SITE SPECIFIC DESIGNS. IF CONDITIONS ENCOUNTERED IN THE FIELD ARE DIFFERENT THAN THOSE INDICATED, THE CONTRACTOR SHALL NOTIFY THE ENGINEER TO DETERMINE IF THE FOUNDATION DIMENSIONS NEED TO BE MODIFIED.

LEGEND:
 F.F. - FRONT FACE
 B.F. - BACK FACE
 CTS. - CENTERS

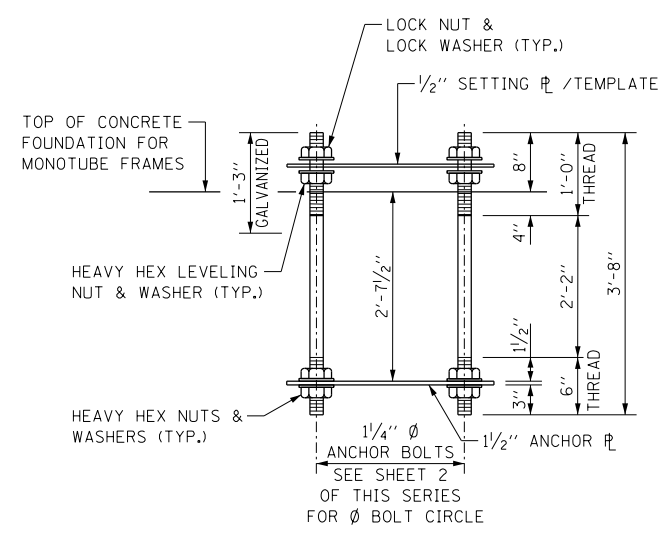

ANCHOR BOLT ASSEMBLY

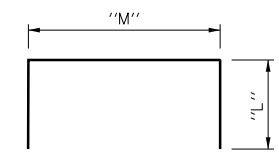

BAR	"L"	"M"	
d1(E)	2'-9"	5'-7"	**
u(E)	2'-9"	3'-8"	
u1(E)	3'-3"	1'-1"	
u2(E)	3'-10"	3'-8"	

BARS d1(E), u(E), u1(E) AND u2(E)

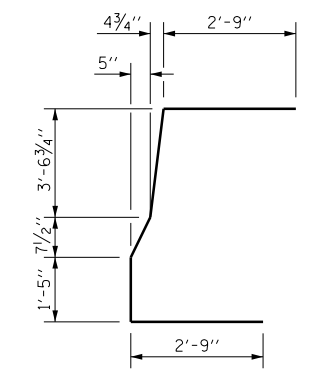

BAR d2(E)

FRAME COLUMN	ANCHOR BOLT
HSS 12.75x0.500	12

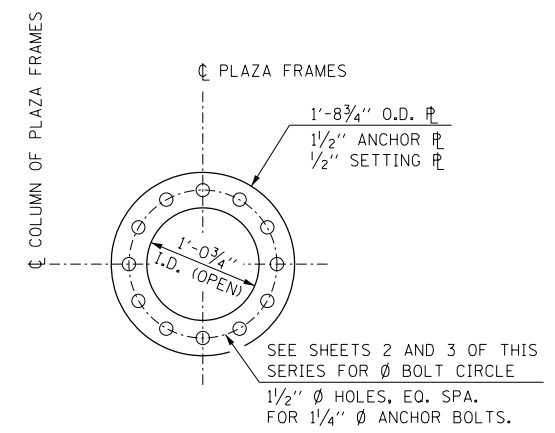

ANCHOR PLATE / SETTING PLATE

BAR LIST-ONE FOUNDATION

BAR	NO.	SIZE	LENGTH	SHAPE	
**	d1(E)	5	#6	11'-1"	
**	d2(E)	5	#6	11'-3"	
*	s(E)	1	#4	30'-7"	MMW
**	v(E)	16	#9	30'-7"	—
	u(E)	10	#5	9'-2"	
	u1(E)	5	#5	7'-7"	
	u2(E)	4	#5	11'-4"	

* THE LENGTH OF SPIRAL SHOWN IS THE HEIGHT OF SPIRAL, COMPUTED USING "C" = 1'-0". ADJUST LENGTH ACCORDINGLY IF "C" IS GREATER THAN 1'-0".

** BAR LENGTH IS COMPUTED USING "C" = 1'-0". ADJUST BAR LENGTH ACCORDINGLY IF "C" IS GREATER THAN 1'-0".

ESTIMATED QUANTITY

ITEM	UNIT	SINGLE FACE BARRIER FDN.
CLASS SI CONCRETE	CU. YD.	3.7
CLASS DS CONCRETE	CU. YD.	6.6
REINFORCEMENT BARS, EPOXY COAT	POUND	2,360
PROTECTIVE COAT	SQ. YD.	5.0

NOTE:
 QUANTITIES FOR SINGLE FACE BARRIER FOUNDATION ARE DETERMINED USING "C" = 1'-0". IF DIMENSION "C" IS GREATER THAN 1'-0", ADJUST QUANTITIES ACCORDINGLY.

APPROVED: *Paul Kovacs* DATE 10-14-2014
 CHIEF ENGINEER



OVERHEAD SIGN STRUCTURE MONOTUBE TYPE (STEEL) STRUCTURE DETAILS FOR AET RAMP
 STANDARD F15-01

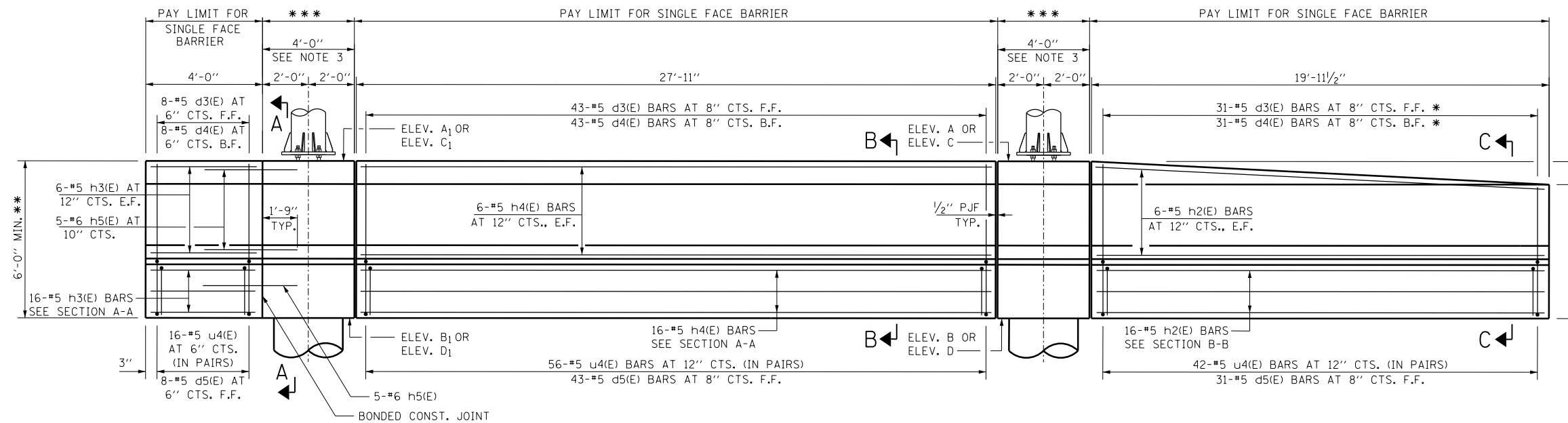

BAR LIST - FOR ONE BARRIER

BAR	NO.	SIZE	LENGTH	SHAPE
d3(E)	82	#5	5'-0"	
d4(E)	82	#5	6'-7"	
d5(E)	82	#5	4'-7"	
h2(E)	28	#5	19'-7"	
h3(E)	28	#5	3'-8"	
h4(E)	28	#5	27'-7"	
h5(E)	10	#6	3'-9"	
u4(E)	114	#5	8'-3"	

SINGLE FACE BARRIER AND BARRIER BASE ELEVATION

INSIDE FACE OF RIGHT BARRIER IS SHOWN
(MIRROR ELEVATION OF LEFT BARRIER)

- * CUT IN FIELD AS REQUIRED TO FIT TAPER
- ** BASED ON DIMENSION "C" = 1'-0"
- *** PAY LIMIT FOR FOUNDATION FOR OVERHEAD SIGN STRUCTURE

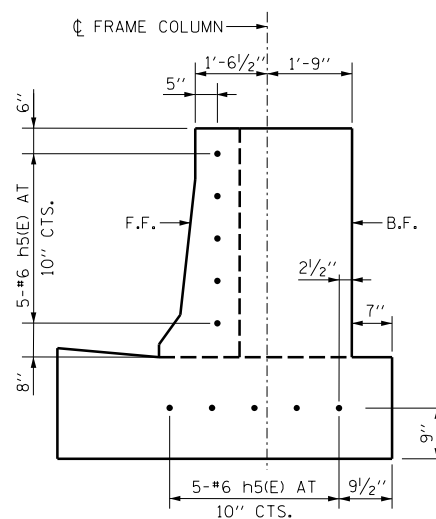

SECTION A-A

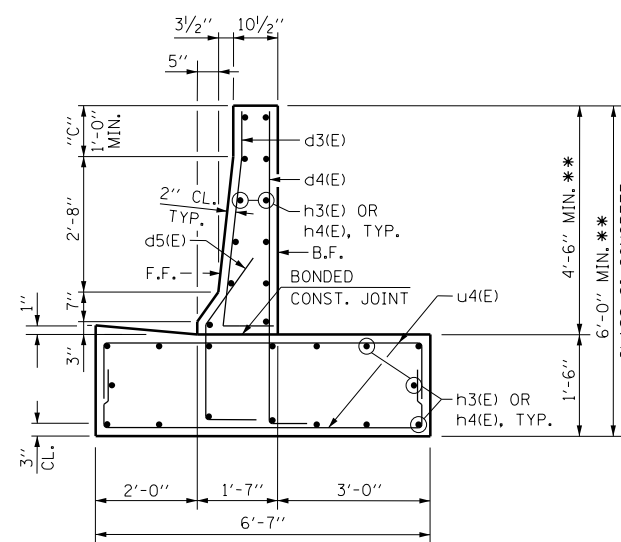

SECTION B-B

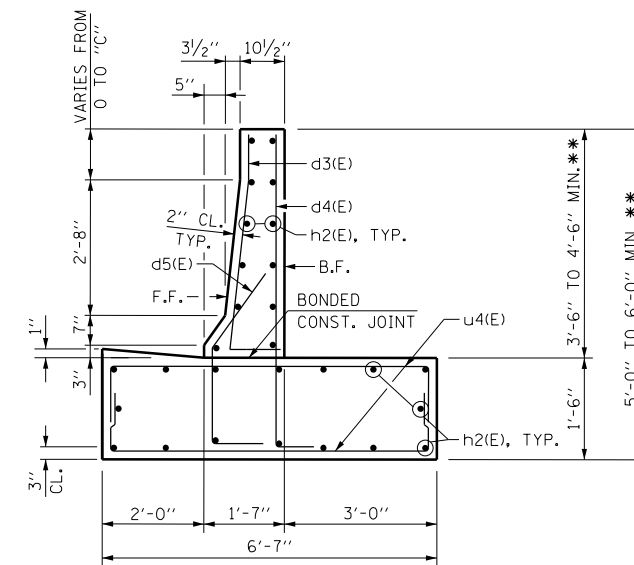

SECTION C-C

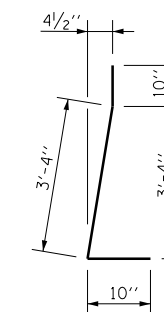

BAR d3(E)

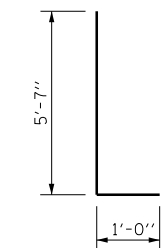

BAR d4(E)

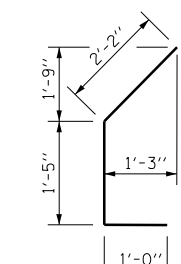

BAR d5(E)

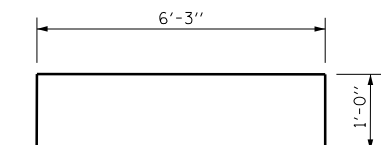

BAR u4(E)

ESTIMATED QUANTITY

(FOR ONE SINGLE FACE BARRIER)

ITEM	UNIT	TOTAL
CONCRETE STRUCTURES	CU. YD.	28.2
REINFORCEMENT BARS, EPOXY COATED	POUND	3,910
PROTECTIVE COAT	SQ. YD.	43.0

NOTES:

1. PROTECTIVE COAT SHALL BE APPLIED TO THE TRAFFIC AND TOP FACES OF THE BARRIER, GUTTER AND TO THE ENTRANCE SIDE FACE (AT THE BEGINNING OF THE RAMP PLAZA PAVEMENT) FOR THE FULL HEIGHT OF THE BARRIER.
2. ELECTRICAL JUNCTION BOXES SHALL BE EXTERIOR MOUNTED ON THE BACK FACE OF BARRIER.
3. FOR SINGLE FACE BARRIER FOUNDATION DETAILS FOR MONOTUBE FRAMES, SEE SHEET 6 OF THIS SERIES.
4. QUANTITIES FOR SINGLE FACE BARRIER ARE DETERMINED USING "C" = 1'-0". IF DIMENSION "C" IS GREATER THAN 1'-0", ADJUST QUANTITIES ACCORDINGLY.
5. SEE OVERHEAD SIGN STRUCTURE ENTRANCE MONOTUBE TYPE (STEEL) AET RAMP SUMMARY AND TOTAL BILL OF MATERIAL IN CONTACT PLANS FOR COMPLETE BILL OF MATERIAL.



OVERHEAD SIGN STRUCTURE
MONOTUBE TYPE (STEEL)
STRUCTURE DETAILS
FOR AET RAMP

STANDARD F15-01

APPROVED: *Paul Kovacs* DATE 10-14-2014
CHIEF ENGINEER

SIGN TABLE

SIGN	MAXIMUM AREA	MAXIMUM LENGTH
PLAZA SIGN	24 S.F.	8'-0"
I-PASS ONLY SIGN	20 S.F.	4'-0"
CASH ONLY SIGN	20 S.F.	4'-0"

NOTE:

1. SEE CONTRACT PLANS FOR SIGN SIZE AND LOCATION.
2. PROVIDE MONOTUBE FRAME STATION IN CONTRACT PLANS.
3. CASH ONLY SIGN OR I-PASS ONLY SIGN. SEE CONTRACT PLANS FOR SIGN PLACEMENT.

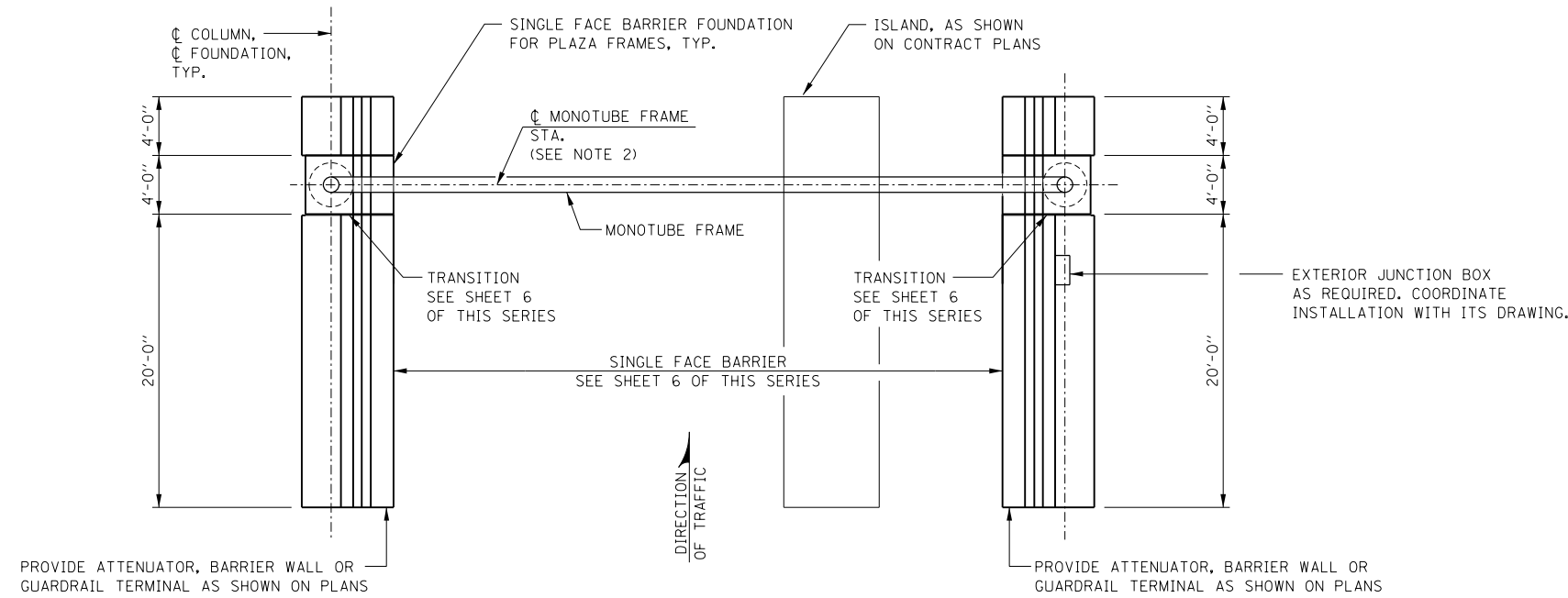

CASH-IPO RAMP TOLL PLAZA PLAN

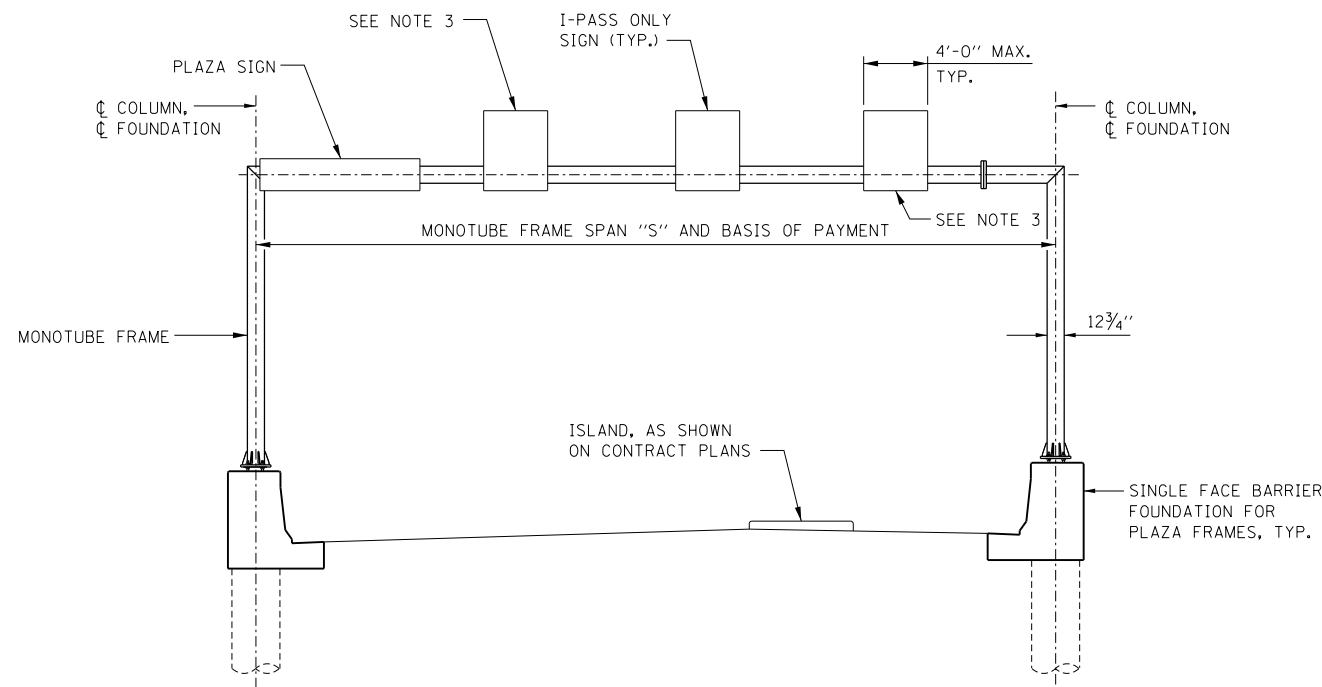

CASH-IPO RAMP TOLL PLAZA ELEVATION



DATE	REVISIONS	OVERHEAD SIGN STRUCTURE MONOTUBE TYPE (STEEL) STRUCTURE DETAILS FOR CASH-IPO RAMP
3-31-2016	REVISED FOUNDATION NOTE.	
		STANDARD F16-01

APPROVED: *Paul Kovacs* CHIEF ENGINEER DATE 10-14-2014

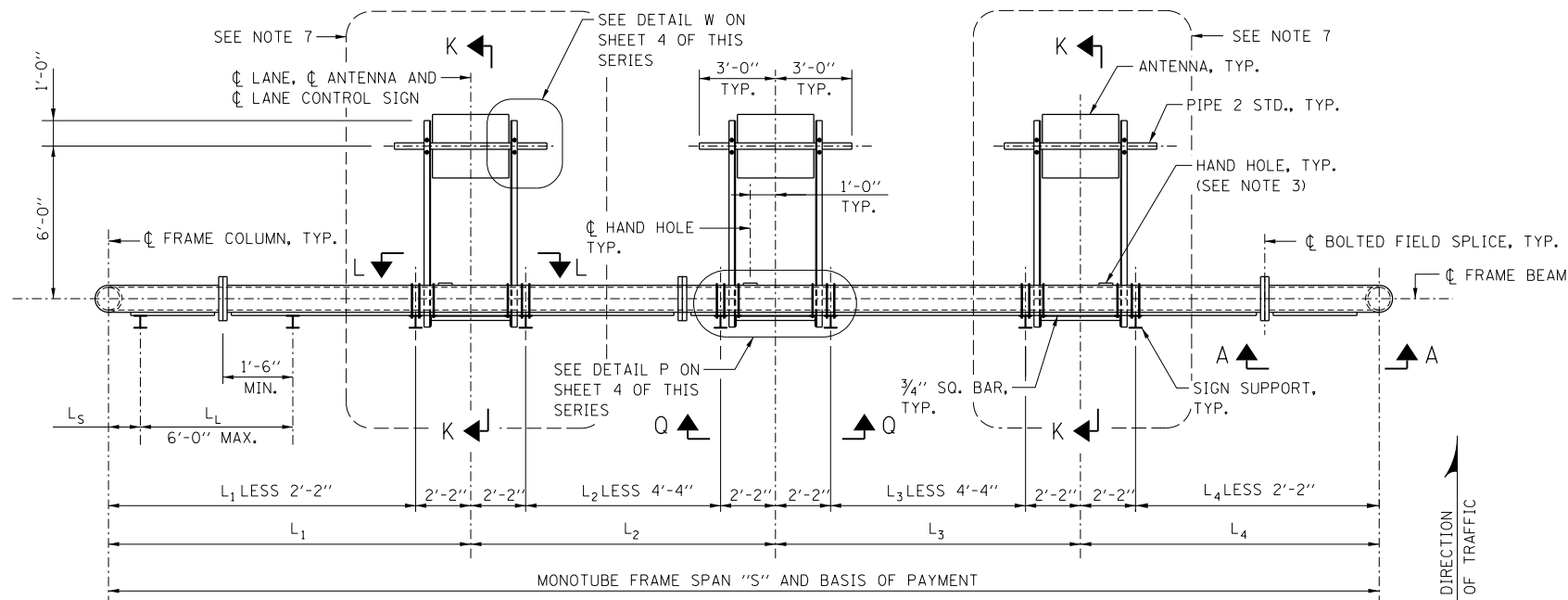

CASH-IPO RAMP MONOTUBE PLAN

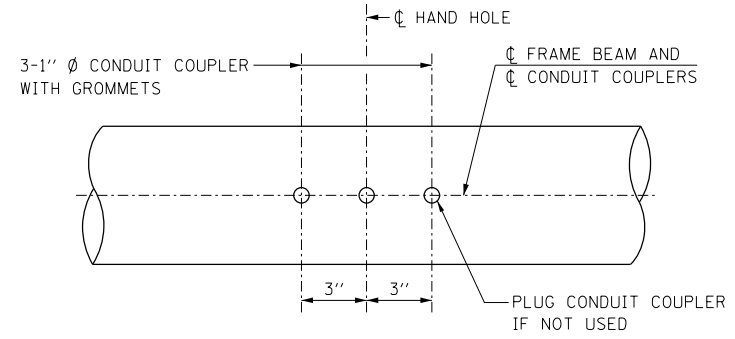

VIEW N-N (CONDUIT COUPLER DETAIL)

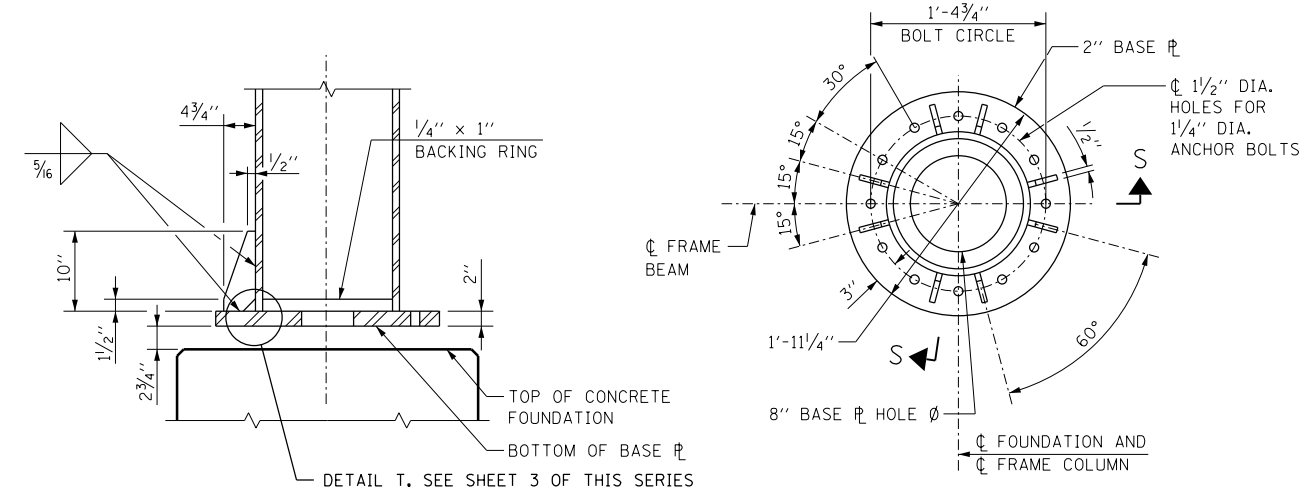

SECTION S-S

BASE PLATE PLAN MONOTUBE FRAME

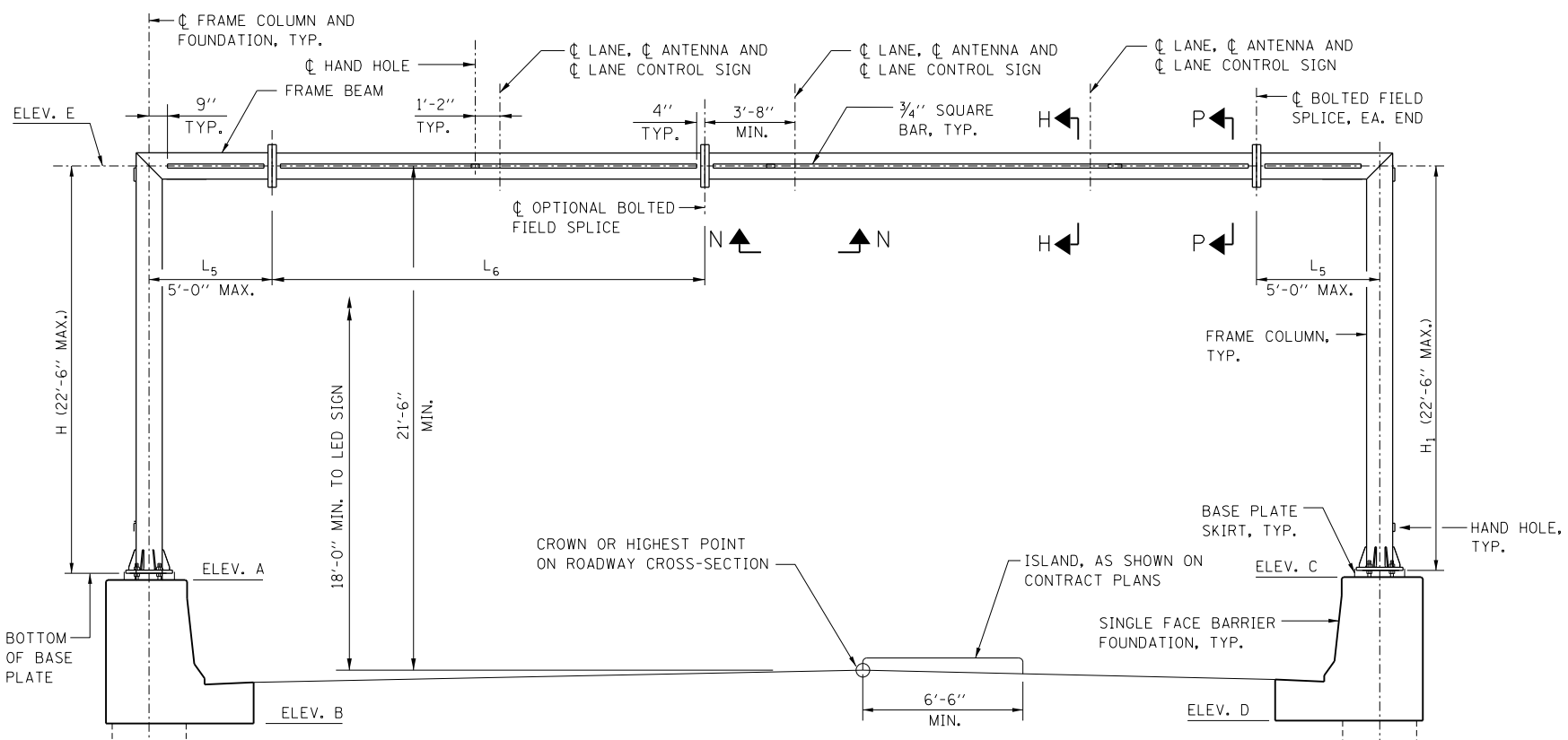

CASH-IPO RAMP MONOTUBE ELEVATION

MONOTUBE FRAME TABLE

SPAN "S"	FRAME COLUMN	FRAME BEAM	CAMBER
60' MAX.	HSS 12.75x0.500	HSS 12.75x0.500	2 1/2"

SEE STANDARD F13 FOR SPANS GREATER THAN 60'

NOTES:

1. WORK THIS SHEET WITH OVERHEAD SIGN STRUCTURE MONOTUBE TYPE (STEEL) CASH-IPO RAMP, SUMMARY AND TOTAL BILL OF MATERIAL SHEET.
2. FOUNDATION FOR MONOTUBE FRAME IS SHOWN ON SHEET 5 OF THIS SERIES.
3. SEE SHEET 4 OF THIS SERIES FOR SECTIONS G-G, H-H AND K-K, VIEWS A-A AND O-O, AND HAND HOLE DETAILS.
4. SEE SHEET 3 OF THIS SERIES FOR SECTION P-P AND BASE PLATE SKIRT.
5. PROVIDE CAMBER AT MIDSPAN OF STRUCTURE.
6. LOCATE OPTIONAL BOLTED FIELD SPLICE NEAR MIDSPAN.
7. OMIT ANTENNA AND ANTENNA MOUNTING ASSEMBLY ABOVE CASH ONLY LANE.



OVERHEAD SIGN STRUCTURE MONOTUBE TYPE (STEEL) STRUCTURE DETAILS FOR CASH-IPO RAMP

STANDARD F16-01

APPROVED... *Paul Kovacs* CHIEF ENGINEER DATE 10-14-2014

GENERAL NOTES:

1. AFTER ADJUSTMENTS TO LEVEL FRAME BEAM AND ENSURE ADEQUATE VERTICAL CLEARANCE, TIGHTEN ALL TOP AND LEVELING NUTS AGAINST THE BASE PLATE WITH A MINIMUM TORQUE OF 200 LB.-FT. THEN PLACE STAINLESS STEEL MESH AROUND THE PERIMETER OF THE BASE PLATE. SECURE TO BASE PLATE WITH STAINLESS STEEL BANDING.
2. REINFORCEMENT BARS DESIGNATED "(E)" SHALL BE EPOXY COATED.
3. FINAL LOCATION OF I-PASS ANTENNAE SHALL BE AS DIRECTED BY THE ILLINOIS TOLLWAY.

STRUCTURAL STEEL:

1. MATERIAL FOR THE MONOTUBE FRAME AND RECTANGULAR HSS SHALL CONFORM TO THE REQUIREMENTS OF ASTM A500 GRADE B. BASE PLATE AND STIFFENER PLATE SHALL CONFORM TO ASTM A709 GRADE 50. OTHER STRUCTURAL STEEL SHAPES AND PLATES SHALL CONFORM TO THE REQUIREMENTS OF ASTM A36, UNLESS NOTED OTHERWISE.
2. PIPES SHALL CONFORM TO THE REQUIREMENTS OF ASTM A53 GRADE B.
3. ANCHOR BOLTS SHALL CONFORM TO THE REQUIREMENTS OF ASTM F1554 (AASHTO M314) GRADE 55, WITH A MINIMUM TENSILE STRENGTH OF 75,000 PSI. THEY SHALL BE GALVANIZED IN ACCORDANCE WITH ASTM A153 (AASHTO M232). SEE SHEET 6 OF THIS SERIES FOR GALVANIZED LENGTH.
4. U-BOLTS SHALL BE STAINLESS STEEL. PROVIDE STAINLESS STEEL WASHERS AND NUTS FOR U-BOLTS.
5. BOLTS (EXCLUDING ANCHOR BOLTS AND U-BOLTS) SHALL BE HIGH STRENGTH STEEL BOLTS.
6. TUBES FOR MONOTUBE FRAME, PIPES, STRUCTURAL STEEL SHAPES AND PLATES SHALL BE GALVANIZED IN ACCORDANCE WITH ASTM A123 AFTER FABRICATION.
7. THE MONOTUBE FRAME BEAM, COLUMNS, BASE PLATE MATERIAL, AND SPLICES ARE CONSIDERED TENSION MEMBERS AND SHALL CONFORM TO THE IMPACT TESTING REQUIREMENT, ZONE 2.

DESIGN LOADING:

WIND LOAD CRITERIA	
SIGN PANEL	35 P.S.F.
COLUMN/BEAM	35 P.S.F.

EQUIPMENT LOADS:

LED LANE CONTROL SIGN	50 LB.
ANTENNA	28 LB.

DESIGN STRESSES FOR REINFORCED CONCRETE:

f'_c = COMPRESSIVE STRENGTH OF CONCRETE (CLASS SJ)	= 3,500 P.S.I.
f'_c = COMPRESSIVE STRENGTH OF CONCRETE (CLASS DS)	= 4,000 P.S.I.
f_y = YIELD STRENGTH OF REINFORCEMENT BARS (GRADE 60)	= 60,000 P.S.I.

FOUNDATION:

MINIMUM UNCONFINED COMPRESSIVE STRENGTH, Q_u FOR ALL LAYERS OF COHESIVE SOILS (CLAYS) SHALL BE 1.25 TON/SQ.FT. AT RAMP FRAMES.

DESIGN SPECIFICATIONS:

1. STRUCTURE DESIGN MANUAL, DATED MARCH, 2014, WITH LATEST DESIGN BULLETINS.
2. AASHTO STANDARD SPECIFICATION FOR STRUCTURAL SUPPORTS FOR HIGHWAY SIGNS, LUMINAIRES AND TRAFFIC SIGNALS, 6TH EDITION.
3. AASHTO LRFD BRIDGE DESIGN SPECIFICATIONS, 6TH EDITION DATED FEBRUARY 2012.
4. ILLINOIS DEPARTMENT OF TRANSPORTATION BRIDGE MANUAL, JANUARY 2012

CONSTRUCTION SPECIFICATIONS:

1. ILLINOIS TOLLWAY SUPPLEMENTAL SPECIFICATIONS TO THE ILLINOIS DEPARTMENT OF TRANSPORTATION STANDARD SPECIFICATIONS FOR ROAD AND BRIDGE CONSTRUCTION, LATEST EDITION.
2. ILLINOIS DEPARTMENT OF TRANSPORTATION STANDARD SPECIFICATIONS FOR ROAD AND BRIDGE CONSTRUCTION, LATEST EDITION.

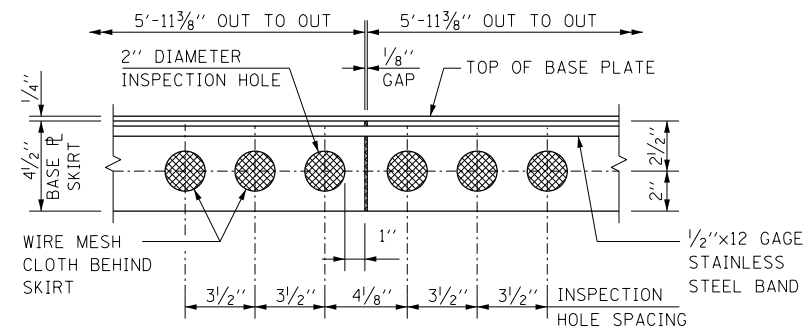
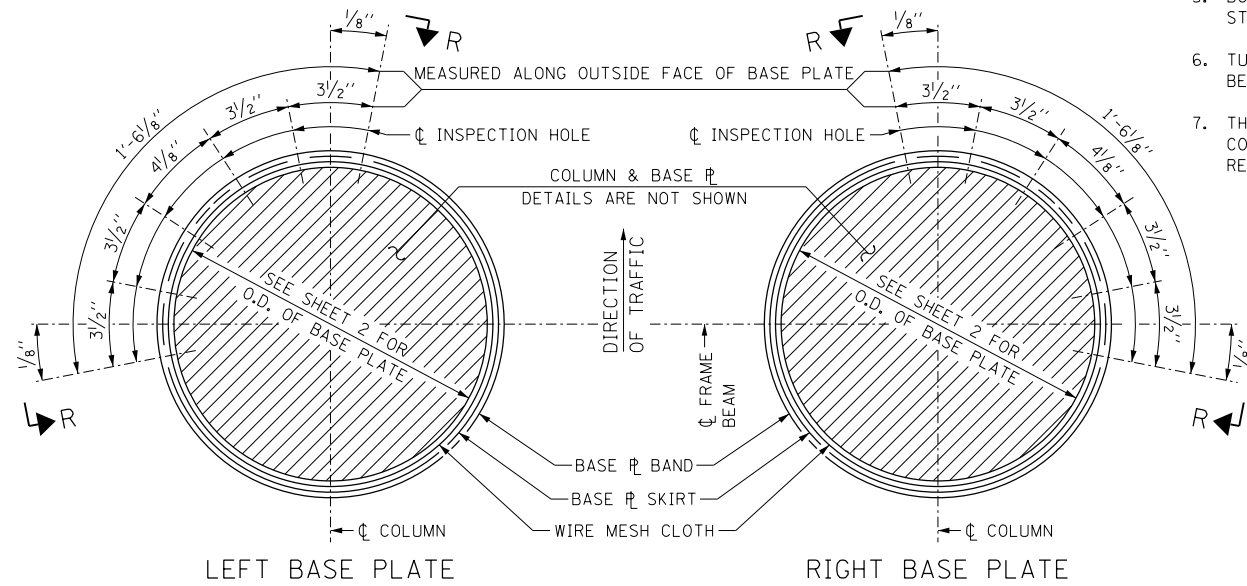

NOTE:

SEE SHEET 4 OF THIS SERIES FOR VIEW F-F.

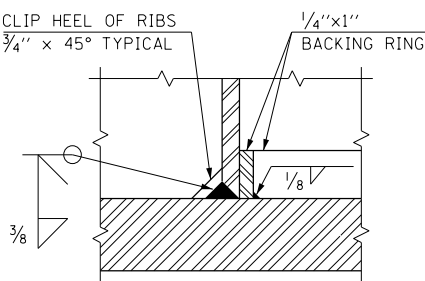
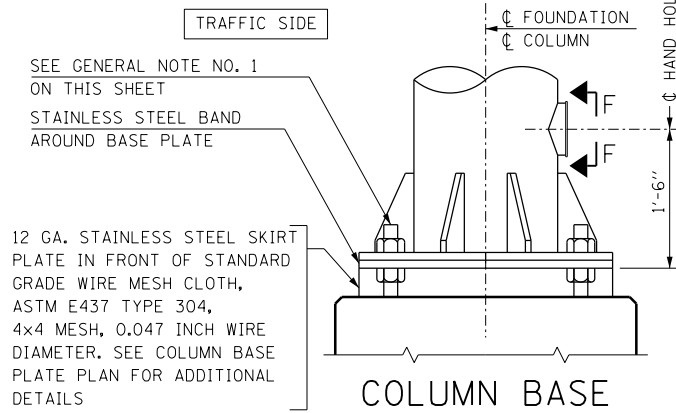

DETAIL T

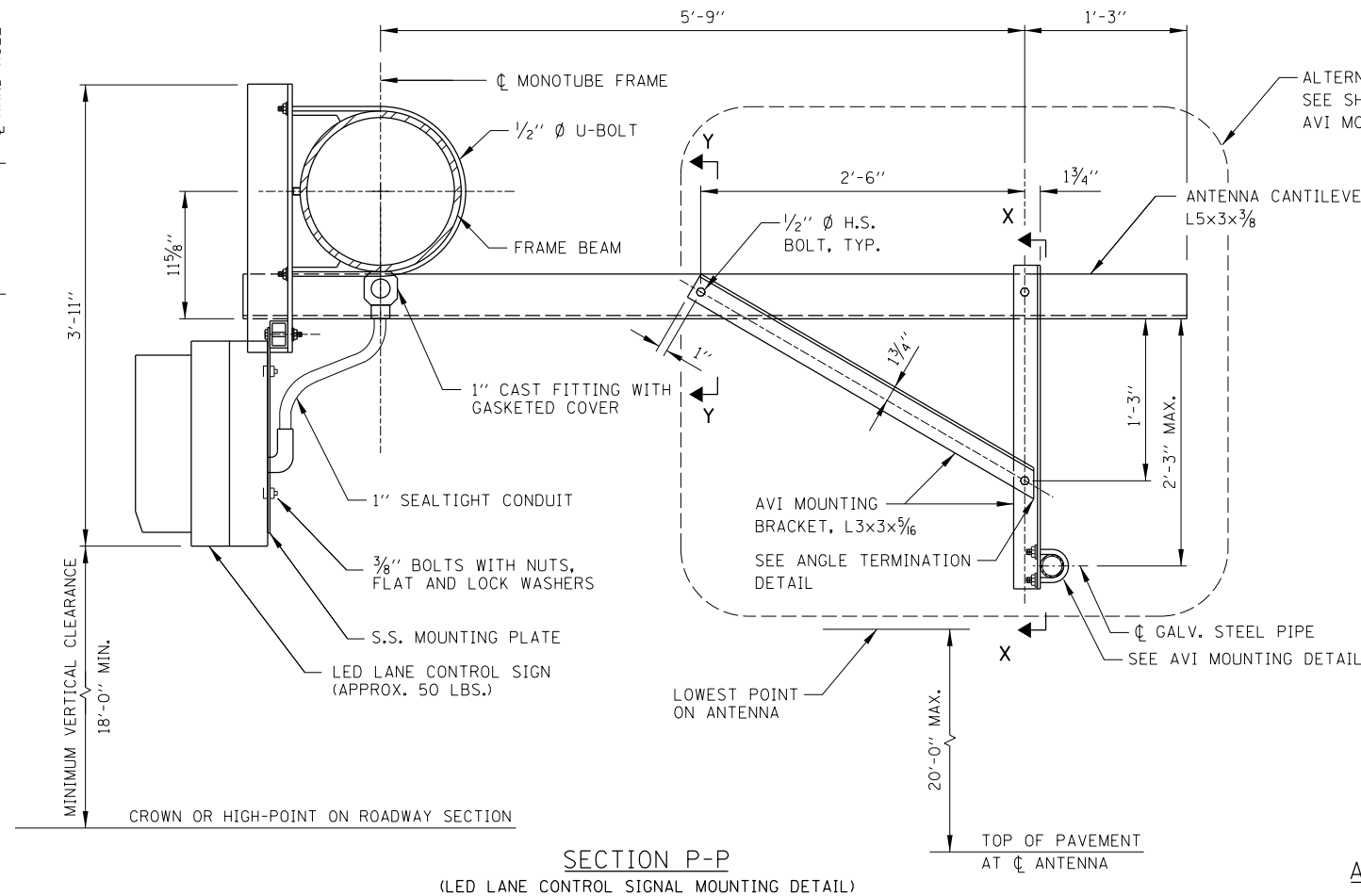

SECTION P-P (LED LANE CONTROL SIGNAL MOUNTING DETAIL)

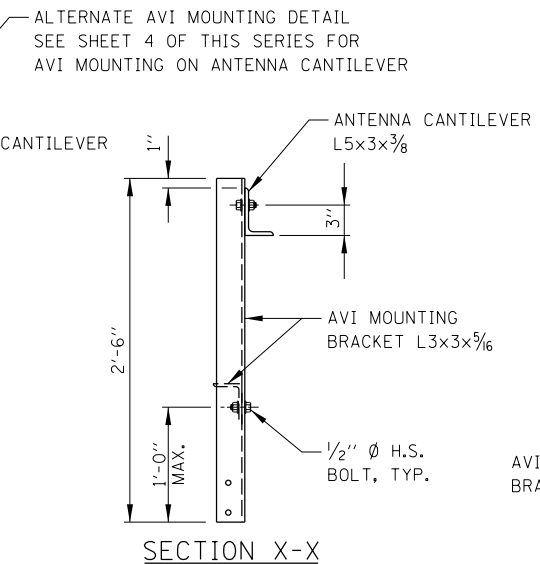

SECTION X-X

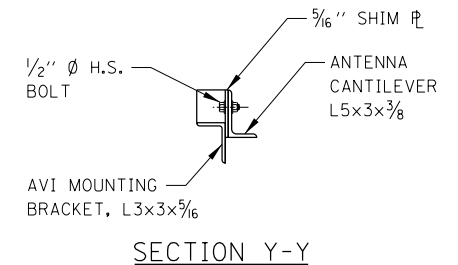

SECTION Y-Y

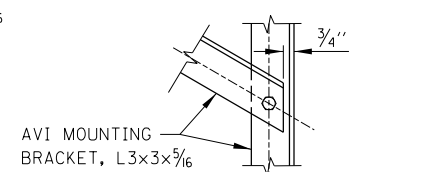

ANGLE TERMINATION

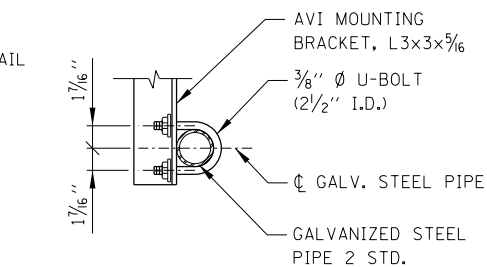

AVI MOUNTING DETAIL



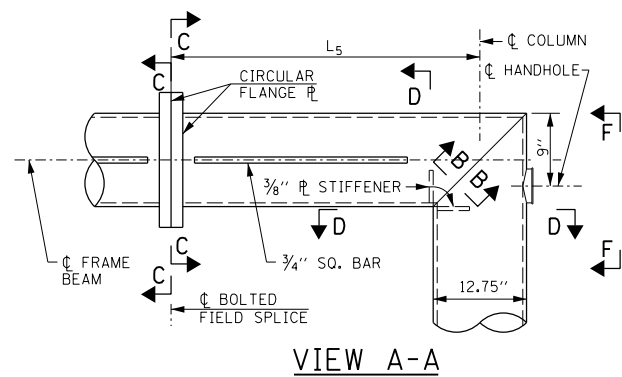

VIEW A-A

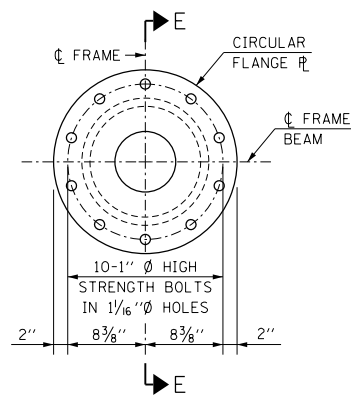

SECTION C-C

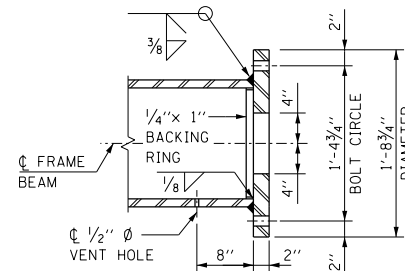

SECTION E-E

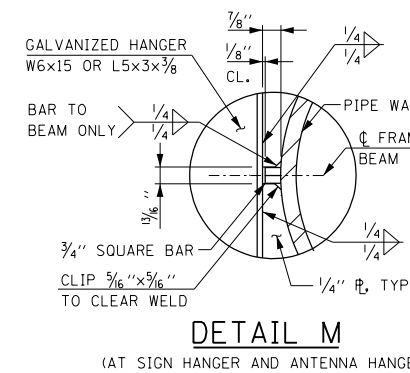

DETAIL M

(AT SIGN HANGER AND ANTENNA HANGER)

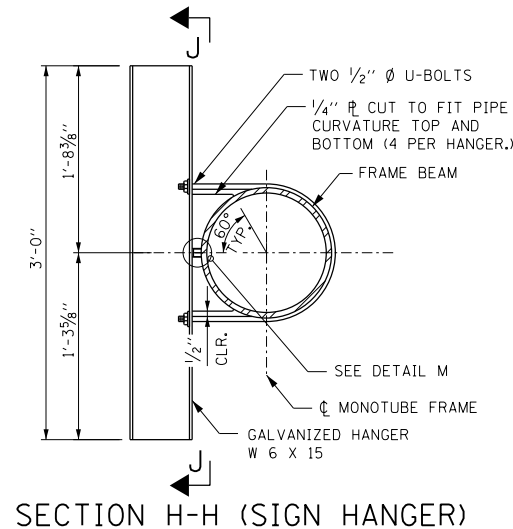

SECTION H-H (SIGN HANGER)

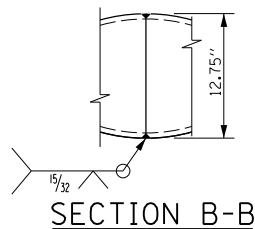

SECTION B-B

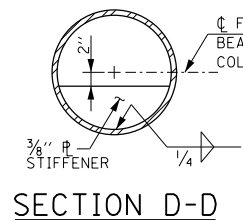

SECTION D-D

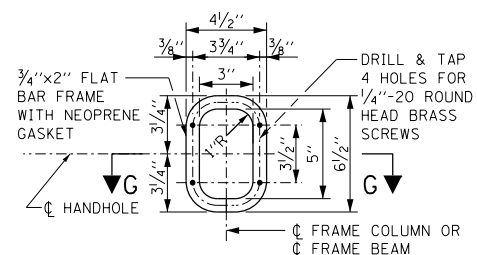

PROVIDE 6 1/2" x 4 1/2" #10 GA. COVER. ROUND CORNERS TO 1 3/4" RADIUS. PROVIDE FOUR 3/8" Ø HOLES.

VIEW F-F

(HAND HOLE DETAIL)

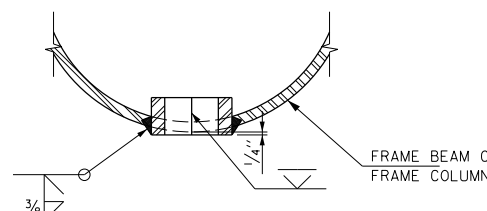

SECTION G-G

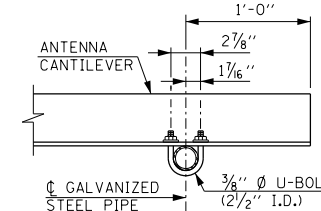

VIEW V-V

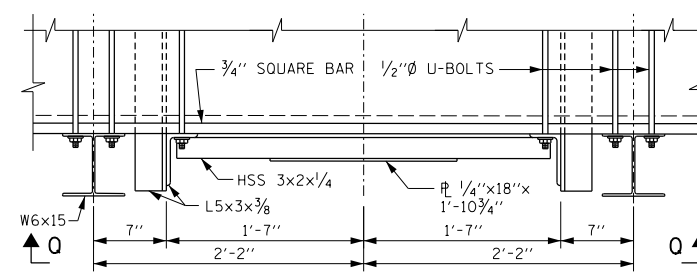

DETAIL P

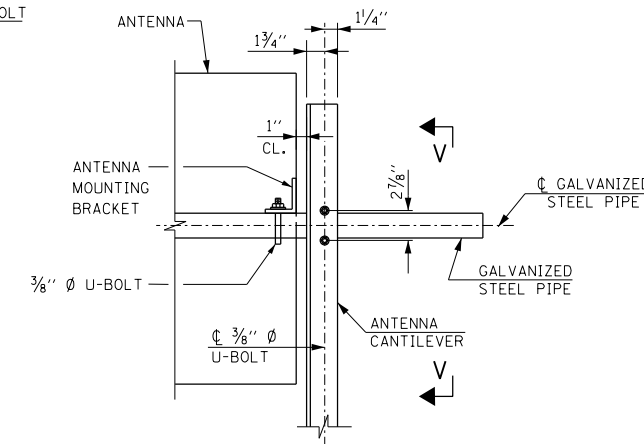

DETAIL W

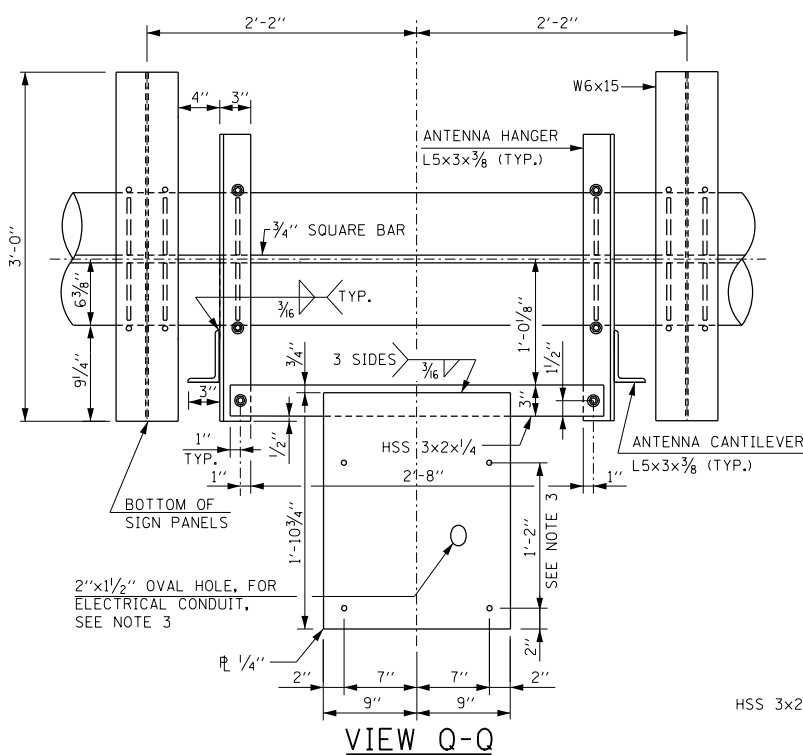

VIEW Q-Q

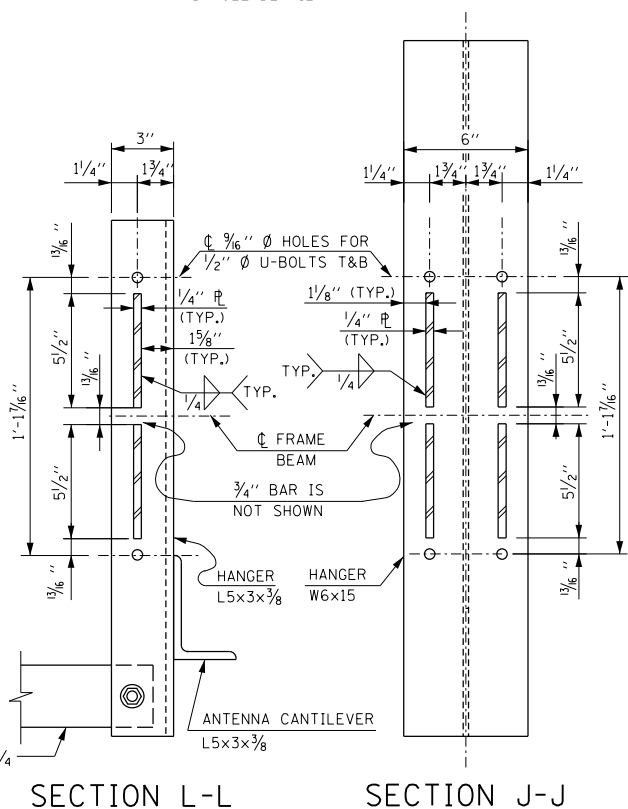

SECTION L-L

SECTION J-J

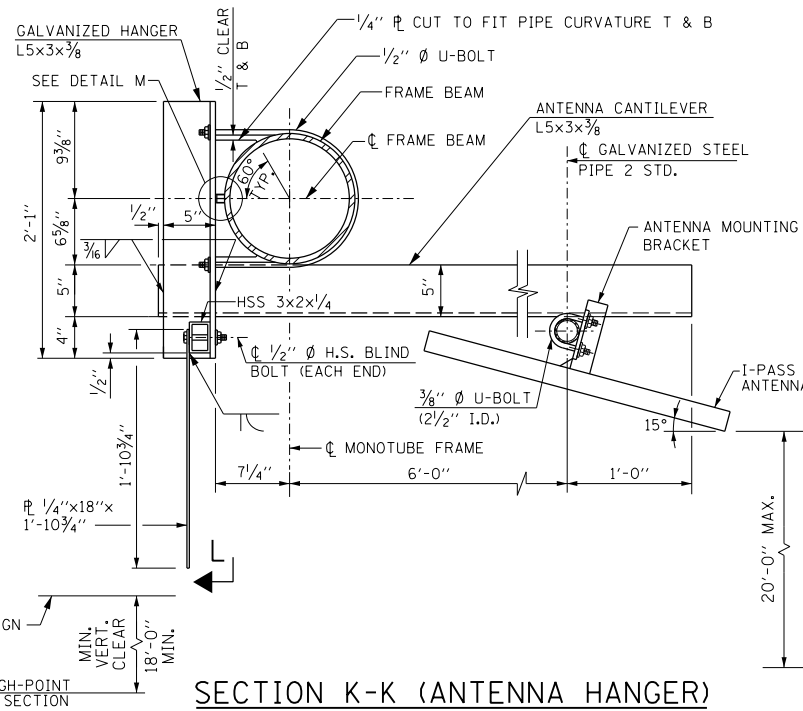

SECTION K-K (ANTENNA HANGER)

(SEE SHEET 3 OF THIS SERIES FOR ALTERNATE AVI MOUNTING DETAIL)

NOTES:

- SIGN AND SIGN HANGER ARE OMITTED FROM VIEW A-A FOR CLARITY.
- FOR DETAILS OF ATTACHMENT BETWEEN HANGER AND SIGN PANELS, SEE ILLINOIS TOLLWAY STANDARD DRAWING F10.
- CONTRACTOR SHALL VERIFY LOCATION AND SIZE OF HOLES WITH LANE CONTROL SIGNAL PRIOR TO FABRICATION OF 1/4" PLATE.
- T&B DENOTE TOP AND BOTTOM.
- PROVIDE ANTENNA MOUNTING BRACKET ACCORDING TO ANTENNA MANUFACTURER'S RECOMMENDATION.
- SEE SHEET 2 OF THIS SERIES FOR HANDHOLE LOCATIONS.



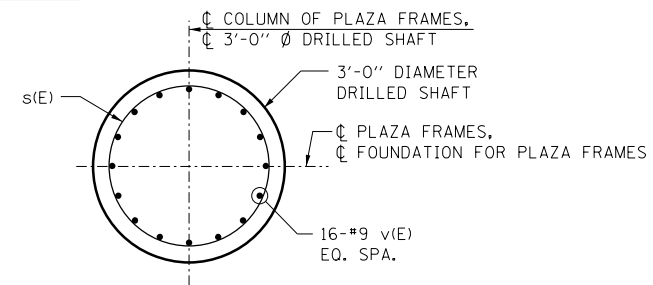
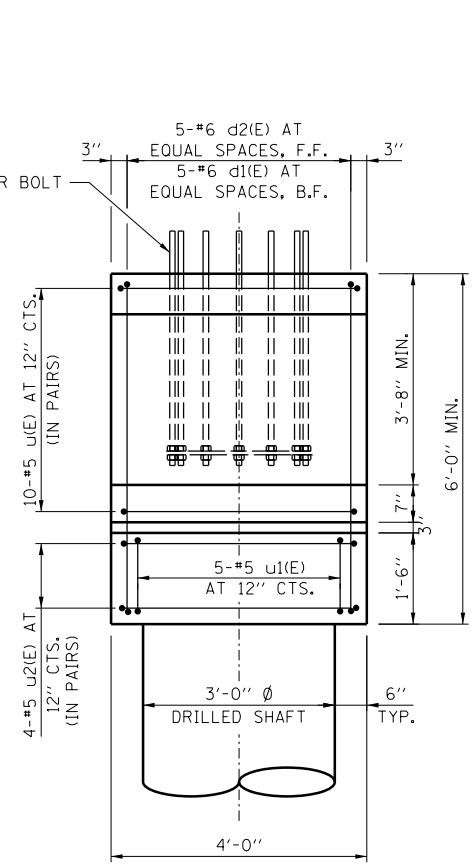
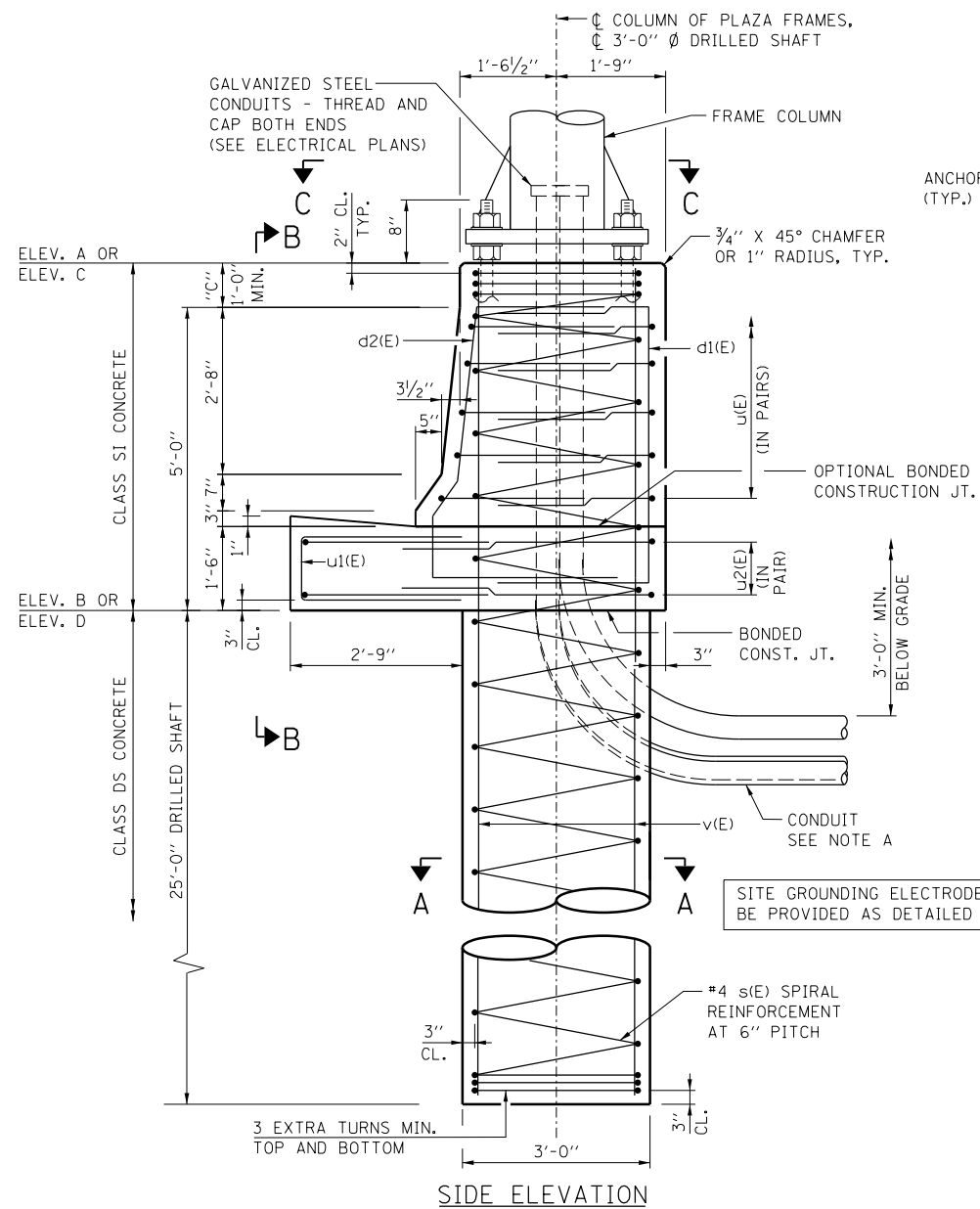

SECTION A-A

- NOTE A:**
1. COORDINATE CONDUIT SIZE, LOCATION AND QUANTITY WITH ELECTRICAL PLANS. PROVIDE CONDUIT COUPLERS AS REQUIRED.
 2. CONDUITS SHALL BE PLACED TO MISS REINFORCEMENT. CUTTING OF REINFORCEMENT SHALL NOT BE ALLOWED.
 3. COST INCLUDED IN FOUNDATION FOR OVERHEAD SIGN STRUCTURE, RAMP MONOTUBE TYPE.
 4. PROTECTIVE COAT SHALL BE APPLIED TO THE TRAFFIC AND TOP FACES OF BARRIER AND TOP OF GUTTER.

FOUNDATIONS:

THE FOUNDATION DETAILS SHOWN ARE BASED ON THE PRESENCE OF MOSTLY COHESIVE SOIL CONDITIONS (SILTY OR SANDY CLAY), WITH AN AVERAGE UNCONFINED COMPRESSIVE STRENGTH (QU) > 1.25 TON/SQ. FT. WHICH MUST BE DETERMINED BY PREVIOUS SOIL INVESTIGATIONS AT THE JOBSITE. WHEN OTHER CONDITIONS ARE INDICATED, THE BORING DATA SHALL BE INCLUDED IN THE PLANS AND THE FOUNDATION DIMENSIONS SHOWN SHALL BE THE RESULT OF SITE SPECIFIC DESIGNS. IF CONDITIONS ENCOUNTERED IN THE FIELD ARE DIFFERENT THAN THOSE INDICATED, THE CONTRACTOR SHALL NOTIFY THE ENGINEER TO DETERMINE IF THE FOUNDATION DIMENSIONS NEED TO BE MODIFIED.

- LEGEND:**
- F.F. - FRONT FACE
 - B.F. - BACK FACE
 - CTS. - CENTERS

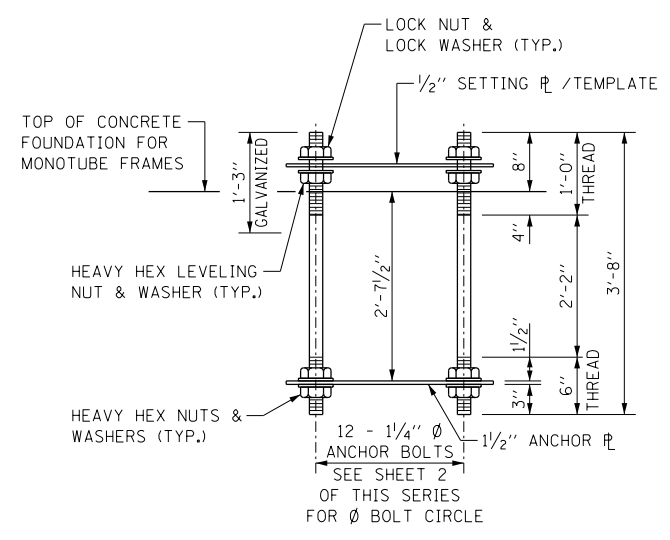

ANCHOR BOLT ASSEMBLY

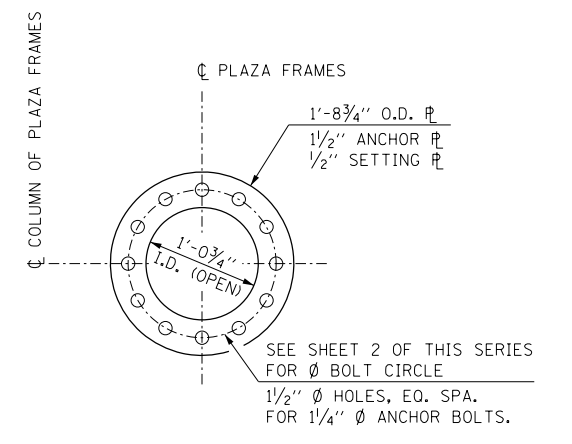

ANCHOR BAR / SETTING BAR

REINFORCEMENT BAR SCHEDULE
FOR ONE FOUNDATION

BAR	NO.	SIZE	LENGTH	SHAPE
** d1(E)	5	#6	11'-1"	□
** d2(E)	5	#6	11'-3"	□
* s(E)	1	#4	30'-7"	WWW
** v(E)	16	#9	30'-7"	—
u(E)	10	#5	9'-2"	□
u1(E)	5	#5	7'-7"	□
u2(E)	4	#5	11'-4"	□

- * THE LENGTH OF SPIRAL SHOWN IS THE HEIGHT OF SPIRAL, COMPUTED USING "C" = 1'-0". ADJUST LENGTH ACCORDINGLY IF "C" IS GREATER THAN 1'-0".
- ** BAR LENGTH IS COMPUTED USING "C" = 1'-0". ADJUST BAR LENGTH ACCORDINGLY IF "C" IS GREATER THAN 1'-0".

ESTIMATED QUANTITY

ITEM	UNIT	SINGLE FACE BARRIER FDN.
CLASS SI CONCRETE	CU. YD.	3.7
CLASS DS CONCRETE	CU. YD.	6.6
REINFORCEMENT BARS, EPOXY COATED	POUND	2,360
PROTECTIVE COAT	SQ. YD.	5.0

NOTE:
QUANTITIES FOR SINGLE FACE BARRIER FOUNDATION ARE DETERMINED USING "C" = 1'-0". IF DIMENSION "C" IS GREATER THAN 1'-0", ADJUST QUANTITIES ACCORDINGLY.

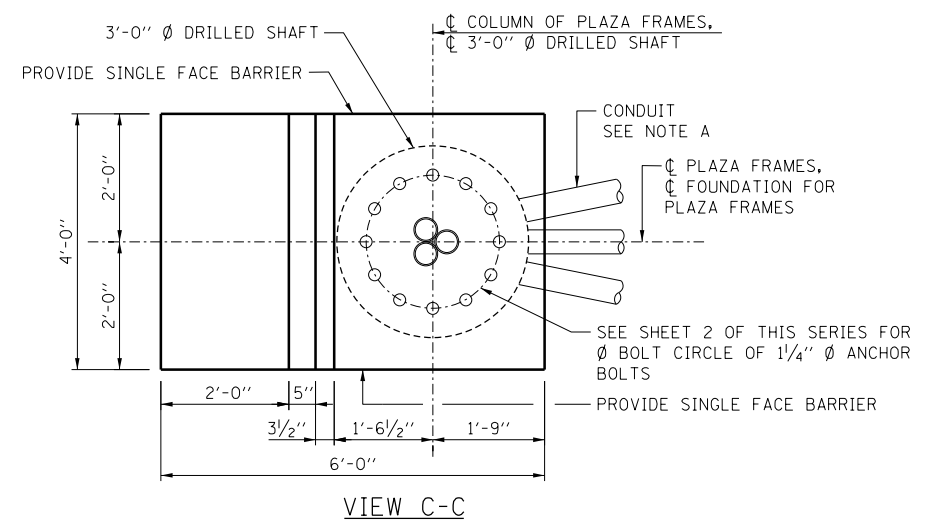

VIEW C-C

SINGLE FACE BARRIER FOUNDATION FOR PLAZA FRAMES

APPROVED: *Paul Kovacs*
CHIEF ENGINEER DATE 10-14-2014



OVERHEAD SIGN STRUCTURE
MONOTUBE TYPE (STEEL)
STRUCTURE DETAILS
FOR CASH-IPO RAMP
STANDARD F16-01

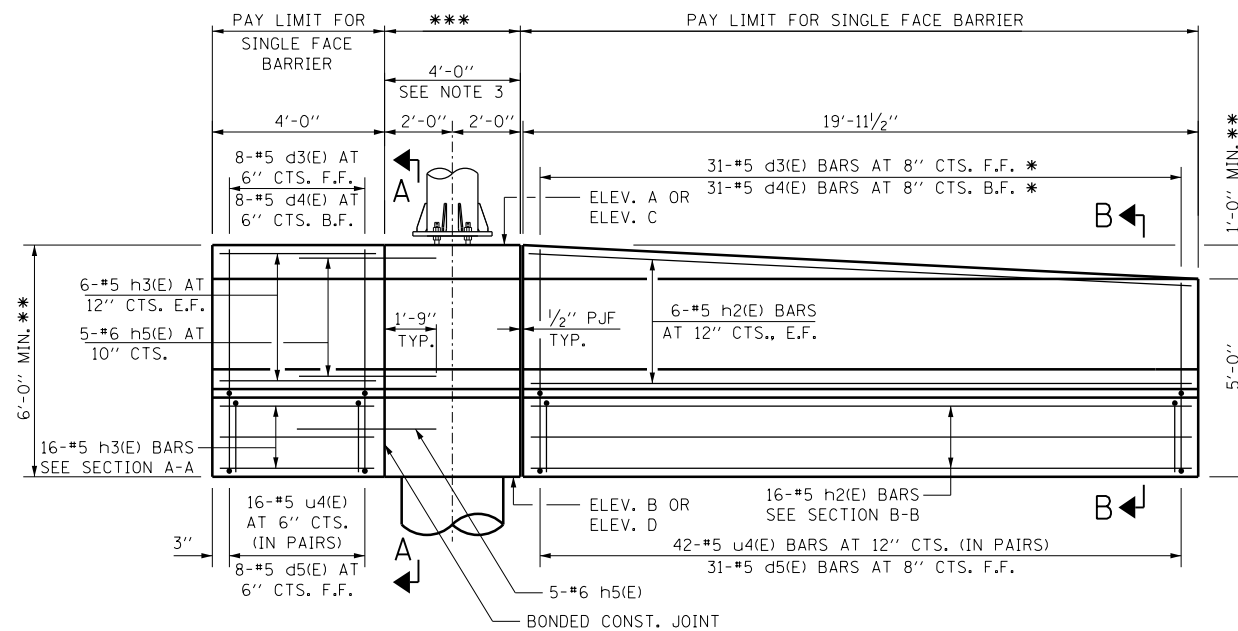

SINGLE FACE BARRIER ELEVATION

INSIDE FACE OF RIGHT BARRIER IS SHOWN
(MIRROR ELEVATION OF LEFT BARRIER)

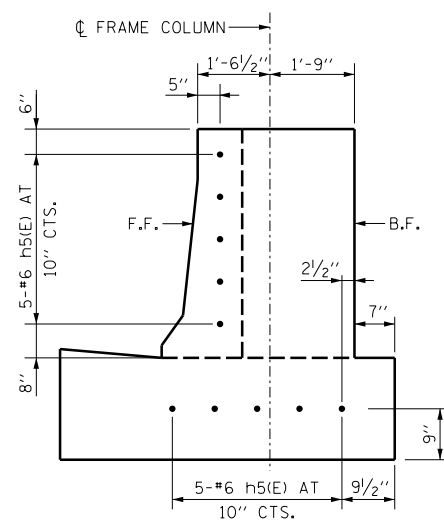

SECTION A-A

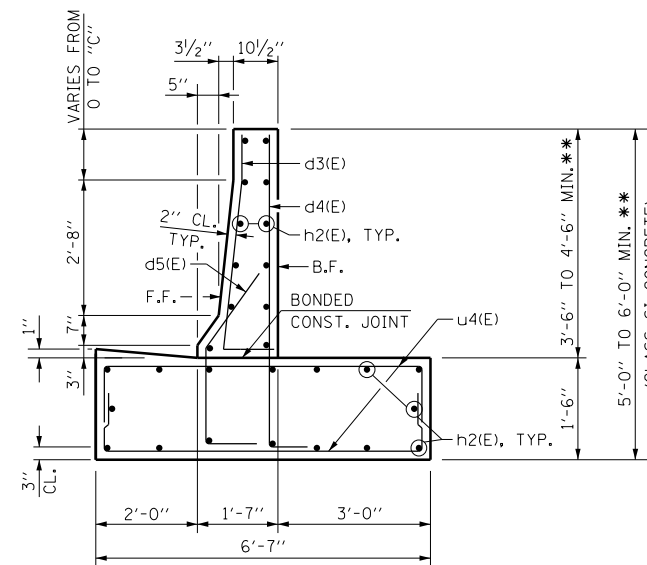

SECTION B-B

BAR LIST - ONE BARRIER

BAR	NO.	SIZE	LENGTH	SHAPE
d3(E)	39	#5	5'-0"	
d4(E)	39	#5	6'-7"	
d5(E)	39	#5	4'-7"	
h2(E)	28	#5	19'-7"	
h3(E)	28	#5	3'-8"	
h5(E)	10	#6	3'-9"	
u4(E)	58	#5	8'-3"	

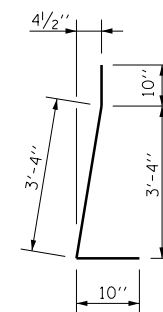

BAR d3(E)

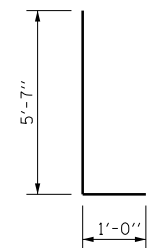

BAR d4(E)

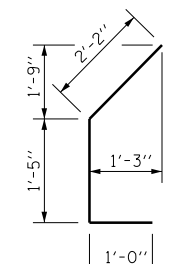

BAR d5(E)

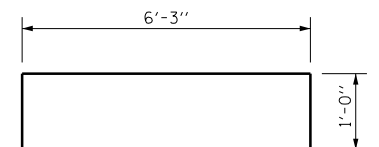

BAR u4(E)

* CUT IN FIELD AS REQUIRED TO FIT TAPER
** BASED ON DIMENSION "C" = 1'-0"
*** PAY LIMIT FOR FOUNDATION FOR OVERHEAD SIGN STRUCTURE

ESTIMATED QUANTITY

(FOR ONE SINGLE FACE BARRIER)

ITEM	UNIT	TOTAL
CONCRETE STRUCTURES	CU. YD.	12.9
REINFORCEMENT BARS, EPOXY COATED	POUND	1,900
PROTECTIVE COAT	SQ. YD.	20.0

NOTES:

- PROTECTIVE COAT SHALL BE APPLIED TO THE TRAFFIC AND TOP FACES OF THE BARRIER, GUTTER AND TO THE ENTRANCE SIDE FACE (AT THE BEGINNING OF THE RAMP PLAZA PAVEMENT) FOR THE FULL HEIGHT OF THE BARRIER.
- ELECTRICAL JUNCTION BOXES SHALL BE EXTERIOR MOUNTED ON THE BACK FACE OF BARRIER.
- FOR SINGLE FACE BARRIER FOUNDATION DETAILS FOR MONOTUBE FRAMES, SEE SHEET 5 OF THIS SERIES.
- QUANTITIES FOR SINGLE FACE BARRIER ARE DETERMINED USING "C" = 1'-0". IF DIMENSION "C" IS GREATER THAN 1'-0", ADJUST QUANTITIES ACCORDINGLY.
- WORK THIS SHEET WITH, OVERHEAD SIGN STRUCTURE MONOTUBE TYPE (STEEL) CASH-IPO RAMP SUMMARY AND TOTAL BILL OF MATERIAL SHEET.



OVERHEAD SIGN STRUCTURE
MONOTUBE TYPE (STEEL)
STRUCTURE DETAILS
FOR CASH-IPO RAMP

STANDARD F16-01

APPROVED: *Paul Kovacs* CHIEF ENGINEER DATE 10-14-2014

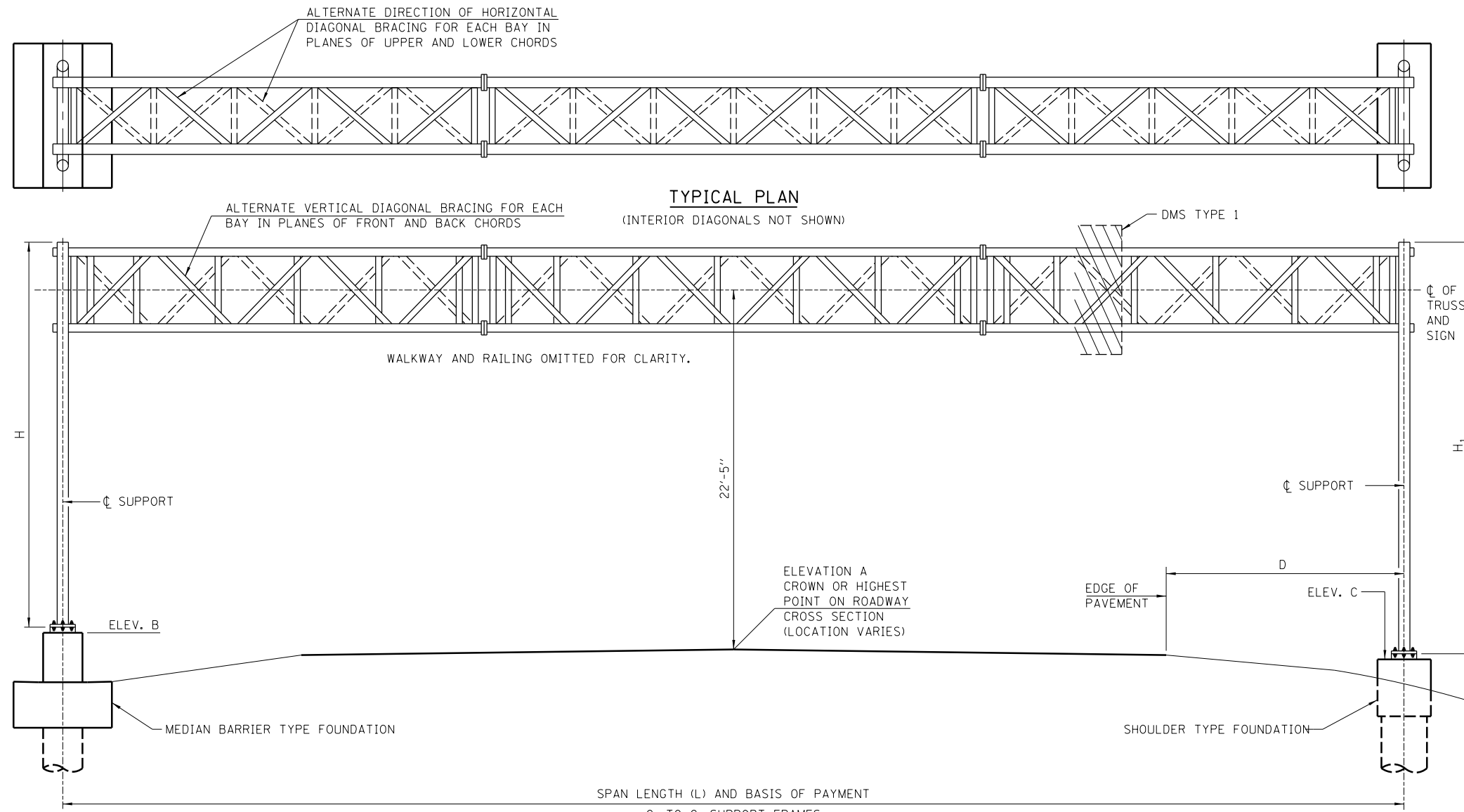

GENERAL NOTES:

1. WORK THIS SHEET WITH, OVERHEAD SIGN STRUCTURE SPAN TYPE (STEEL) SUMMARY AND BILL OF MATERIAL SHEET.
2. AFTER ADJUSTMENTS TO LEVEL TRUSS AND ENSURE ADEQUATE VERTICAL CLEARANCE, ALL TOP AND LEVELING NUTS SHALL BE TIGHTENED AGAINST THE BASE PLATE WITH A MINIMUM TORQUE OF 200 LB.-FT. STAINLESS STEEL MESH SHALL THEN BE PLACED AROUND THE PERIMETER OF THE BASE PLATE. SECURE TO BASE PLATE WITH STAINLESS STEEL BANDING.
3. SIGN SUPPORT STRUCTURES MAY BE SUBJECT TO DAMAGING VIBRATIONS AND OSCILLATIONS WHEN DMS IS NOT IN PLACE DURING ERECTION OR MAINTENANCE OF THE STRUCTURE. TO AVOID THESE, ATTACH TEMPORARY BLANK SIGN PANELS OR OTHER BRACING TO THE STRUCTURE UNTIL DMS IS INSTALLED.
4. TRUSS UNITS SHALL BE SHIPPED INDIVIDUALLY WITH ADEQUATE PROVISION TO PREVENT DETRIMENTAL MOTION DURING TRANSPORT. THE CONTRACTOR IS RESPONSIBLE FOR MAINTAINING THE CONFIGURATION AND PROTECTION OF THE TRUSS UNITS.
5. ALL WELDS SHALL BE CONTINUOUS UNLESS OTHERWISE SHOWN. ALL WELDING SHALL BE DONE IN ACCORDANCE WITH CURRENT AWS D1.1 STRUCTURE WELDING CODE AND THE STANDARD SPECIFICATIONS.
6. INSTALLATIONS NOT WITHIN DIMENSIONAL LIMITS SHOWN REQUIRE SPECIAL ANALYSIS FOR ALL COMPONENTS.
7. ONE DMS TYPE 1 IS PERMITTED TO BE MOUNTED ON A SPAN TRUSS. DO NOT MOUNT SIGN PANELS ON THIS TRUSS.

FABRICATION NOTES:

1. MATERIALS: SEE MATERIAL SPECIFICATIONS TABLE FOR MATERIAL SPECIFICATIONS FOR OVERHEAD SIGN STRUCTURE SPAN TYPE (STEEL). STAINLESS STEEL FOR SHIMS, SLEEVES AND HANDHOLE COVERS SHALL BE ASTM A240, TYPE 302 OR 304 OR ANOTHER ALLOY SUITABLE FOR EXTERIOR EXPOSURE AND ACCEPTABLE TO THE ENGINEER. THE STEEL PIPE AND STIFFENING RIBS AT THE BASE PLATE FOR THE STEEL POST SHALL HAVE A MINIMUM LONGITUDINAL CHARPY V-NOTCH (CVN) ENERGY OF 15 LB.-FT. AT 40°F (ZONE 2) BEFORE GALVANIZING.
2. WELDING: ALL MATERIALS, WELDING PROCEDURES AND INSPECTION USED FOR THE SPAN TYPE OVERHEAD SIGN STRUCTURE SHALL CONFORM TO AWS D1.1-10 FOR TUBULAR, CYCLICALLY LOADED STRUCTURES. ADDITIONALLY, ALL WELDED MATERIALS USED SHALL BE PREQUALIFIED FOR USE WITH WPS PER AWS D1.1-10, TABLE 3.1.
3. FASTENERS FOR STEEL TRUSSES: HIGH STRENGTH BOLTS MUST SATISFY THE REQUIREMENTS OF AASHTO M164 (ASTM A325), OR APPROVED ALTERNATE, AND MUST HAVE MATCHING LOCKNUTS. THREADED STUDS FOR SPLICES (IF MEMBERS INTERFERE) MUST SATISFY THE REQUIREMENTS OF ASTM A449, ASTM A193 GRADE B7, OR APPROVED ALTERNATE, AND MUST HAVE MATCHING LOCKNUTS. BOLTS AND LOCKNUTS NOT REQUIRED TO BE HIGH STRENGTH MUST SATISFY THE REQUIREMENTS OF ASTM A307. ALL BOLTS AND LOCKNUTS MUST BE HOT DIP GALVANIZED PER AASHTO M232, EXCEPT STAINLESS STEEL FASTENERS, NUTS AND WASHERS. THE LOCKNUTS MUST HAVE NYLON OR STEEL INSERTS. A STAINLESS STEEL FLAT WASHER CONFORMING TO ASTM A240 TYPE 302 OR 304, IS REQUIRED UNDER BOTH HEAD AND NUT OR UNDER BOTH NUTS WHERE THREADED STUDS ARE USED. HIGH STRENGTH BOLT INSTALLATION SHALL CONFORM TO ARTICLE 505.04(f)(2)d OF THE IDOT STANDARD SPECIFICATIONS FOR ROAD AND BRIDGE CONSTRUCTION. ROTATIONAL CAPACITY ("ROCAP") TESTING OF BOLTS WILL NOT BE REQUIRED.
4. U-BOLTS: U-BOLTS MUST BE PRODUCED FROM ASTM A193 GRADE B8 OR B8M, OR AN EQUIVALENT MATERIAL ACCEPTABLE TO THE ENGINEER. ALL NUTS FOR U-BOLTS MUST BE LOCKNUTS EQUIVALENT TO ASTM A307 WITH NYLON OR STEEL INSERTS AND HOT DIP GALVANIZED PER AASHTO M232. A STAINLESS STEEL FLAT WASHER CONFORMING TO ASTM A240, TYPE 302 OR 304, IS REQUIRED UNDER EACH U-BOLT LOCKNUT.
5. STEEL GRATING: STEEL BARS FOR GRATING ELEMENTS SHALL CONFORM TO ASTM A36 OR AN EQUIVALENT MATERIAL ACCEPTABLE TO THE ENGINEER.
6. GALVANIZING: ALL PLATES, SHAPES AND PIPE SHALL BE HOT DIP GALVANIZED AFTER FABRICATION IN ACCORDANCE WITH AASHTO M111. PAINTING IS NOT PERMITTED. ALL FASTENERS SHALL BE HOT DIP GALVANIZED IN ACCORDANCE WITH AASHTO M111 OR M232 AS APPROPRIATE FOR THE PRODUCT (EXCEPT STAINLESS STEEL FASTENERS).

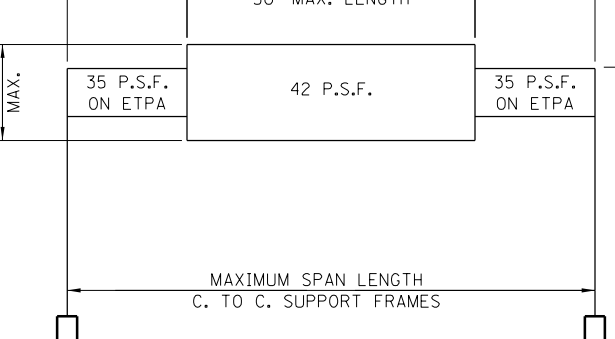

MATERIAL SPECIFICATIONS TABLE FOR STRUCTURAL STEEL AND FASTENERS

ELEMENT OF STRUCTURE	SPECIFICATION	MINIMUM YIELD STRENGTH (K.S.I.)	MINIMUM ULTIMATE STRENGTH (K.S.I.)
HOLLOW STRUCTURAL SECTIONS (HSS)	ASTM A500 GRADE B	42	58
STRUCTURAL STEEL PIPE	ASTM A53, TYPE E OR S, GRADE B	35	60
STRUCTURAL STEEL BAR, PLATES AND SHAPES	ASTM A572 GRADE 50	50	65
STAINLESS STEEL BOLTS	ASTM A193 GRADE B8 OR B8M	30	75
STRUCTURAL STEEL BOLTS	ASTM 325, TYPE 1	--	105
STAINLESS STEEL LOCKNUTS	ASTM A194 GRADE 8F ASTM A194 GRADE 2H	--	--
NUTS	ASTM A563 GRADE DH	--	--
STEEL WASHERS	ASTM F436	--	--
STAINLESS STEEL WASHERS	ASTM A240, TYPE 302	--	--
STEEL ANCHOR BOLTS	AASHTO M314 OR ASTM F1554	105	125

CONSTRUCTION SPECIFICATIONS:

1. ALL MATERIALS, EXCEPT AS SHOWN, FABRICATION, ERECTION AND CONSTRUCTION REQUIREMENTS SHALL BE IN ACCORDANCE WITH THE LATEST STANDARD SPECIFICATIONS.
2. THE COST OF FURNISHING AND INSTALLING THE STAINLESS STEEL BAND AND WIRE MESH CLOTH IS INCLUDED IN THE COST OF "OVERHEAD SIGN STRUCTURE, SPAN TYPE (STEEL)".
3. THE AASHTO GROUP II AND III ALLOWABLE STRESS SHALL BE 133% (ALLOWABLE STRESS DESIGN).
4. WALKWAY LOADING SHALL INCLUDE DEAD LOAD PLUS 500 LBS. CONCENTRATED LIVE LOAD.

DESIGN SPECIFICATIONS:

THESE STRUCTURES ARE DESIGNED TO SATISFY THE 2013 AASHTO STANDARD SPECIFICATIONS FOR STRUCTURAL SUPPORTS FOR HIGHWAY SIGNS, LUMINAIRES AND TRAFFIC SIGNALS, SIXTH EDITION.



DATE	REVISIONS
3-31-2016	REVISED FOUNDATION NOTE.

OVERHEAD SIGN STRUCTURE SPAN TYPE (STEEL) STRUCTURE DETAILS
STANDARD F17-01

Paul Kovacs
APPROVED..... CHIEF ENGINEER..... DATE 5-20-2014.

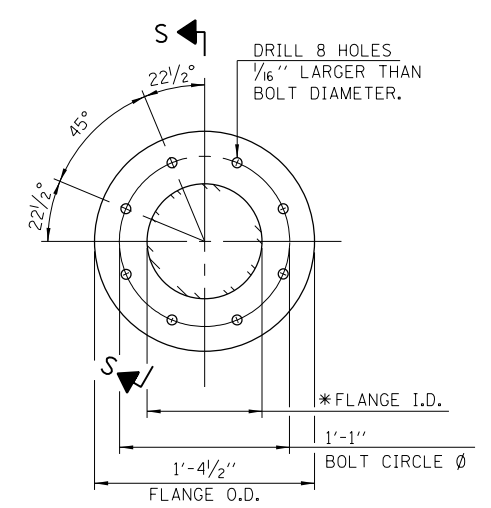
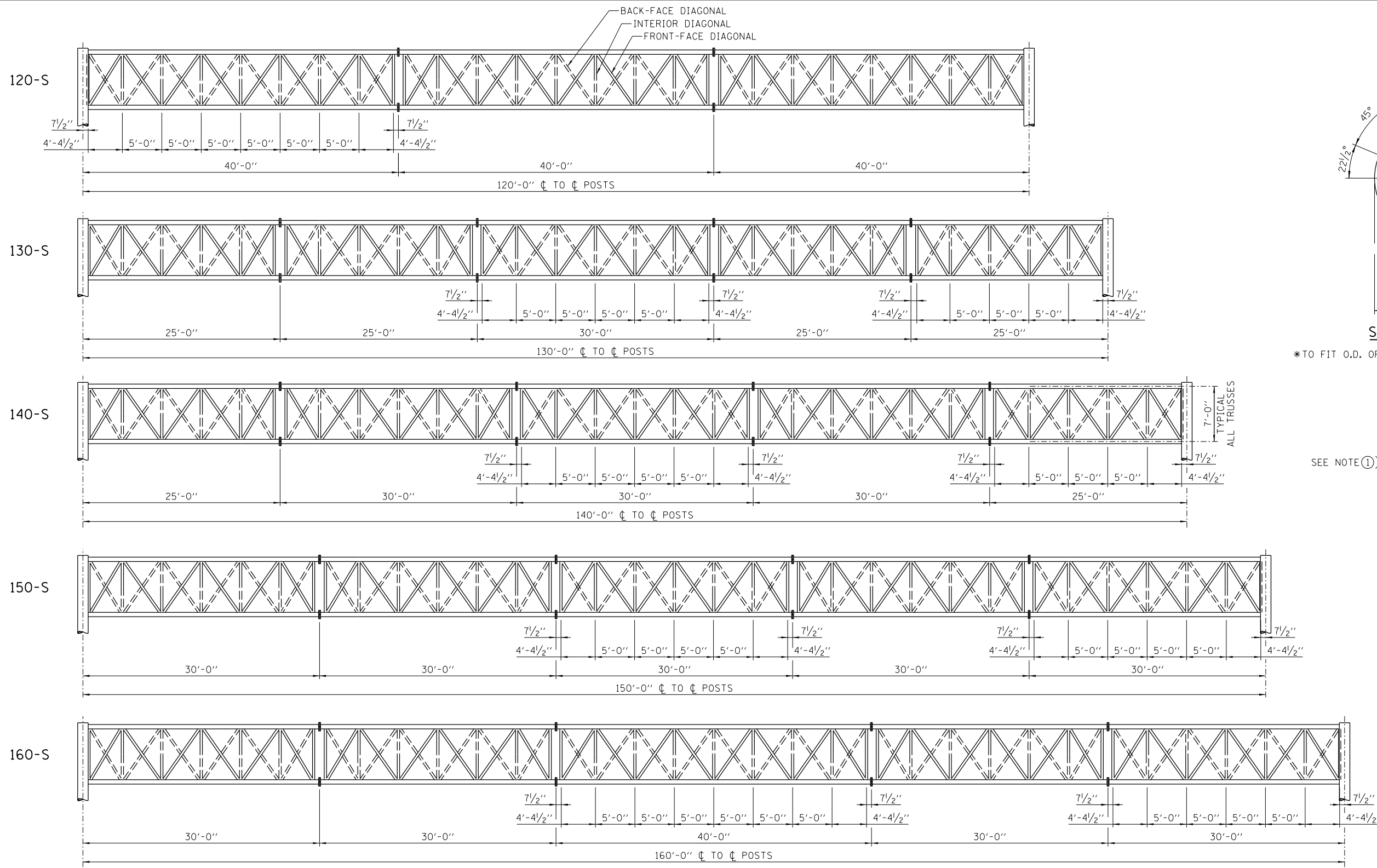

*TO FIT O.D. OF CHORD WITH MAXIMUM GAP OF 1/16".

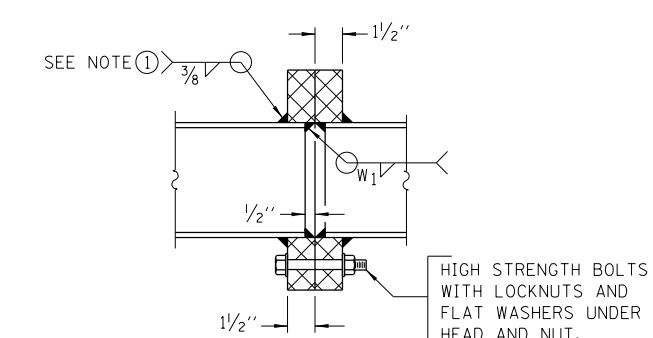

NOTE:
 ① SPlicing FLANGES SHALL BE ATTACHED TO EACH TRUSS UNIT WITH THE TRUSS SHOP ASSEMBLED TO CAMBER SHOWN. TRUSS UNITS SHALL BE IN PROPER ALIGNMENT AND FLANGE SURFACES SHALL BE SHOP BOLTED INTO FULL CONTACT BEFORE WELDING. SUFFICIENT EXTERNAL WELDS OR TACKS SHALL BE MADE TO SECURE FLANGES UNTIL REMAINING WELDS ARE MADE AFTER DISASSEMBLY. ADJACENT FLANGES SHALL BE "MATCH MARKED" TO INSURE PROPER FIELD ASSEMBLY.

PART ELEVATION VIEWS

SPAN LENGTH (L)	CAMBER
120'	2 3/4"
130'	3 1/4"
140'	4"
150'	4 1/4"
160'	5"

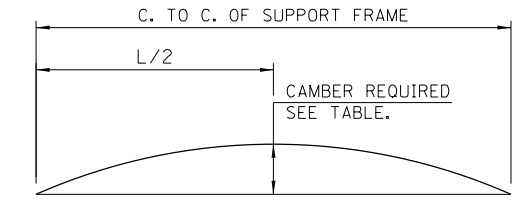

NOTE:
 1. FABRICATE TRUSS WITH CHORDS CURVED SMOOTHLY TO PROVIDE CAMBER.
 2. DO NOT CAMBER BY SHIMMING AT TRUSS FIELD SPLICES OR CUTTING AND REWELDING CHORD.

TRUSS MEMBER SCHEDULE

DESIGN TRUSS TYPE	SPAN	CHORDS	VERTICAL DIAGONALS, VERTICALS AND INTERIOR DIAGONALS	HORIZONTAL DIAGONALS	HORIZONTALS	SPlicing FLANGE		
						H.S. BOLTS		WELD SIZE
						NO./SPLICE	DIA.	
120-S	120'	HSS 8.625x0.322	PIPE 3 1/2 X-STRONG	PIPE 3 XX-STRONG	PIPE 3 X-STRONG	8	1"	1/4"
130-S	130'	HSS 8.625x0.375	PIPE 3 1/2 X-STRONG	PIPE 3 XX-STRONG	PIPE 3 X-STRONG	8	1"	5/16"
140-S	140'	HSS 8.625x0.375	PIPE 3 1/2 X-STRONG	PIPE 3 XX-STRONG	PIPE 3 X-STRONG	8	1"	3/16"
150-S	150'	HSS 8.625x0.500	PIPE 3 1/2 X-STRONG	PIPE 3 XX-STRONG	PIPE 3 X-STRONG	8	1"	7/16"
160-S	160'	HSS 8.625x0.500	PIPE 3 1/2 X-STRONG	PIPE 3 XX-STRONG	PIPE 3 X-STRONG	8	1 1/4"	7/16"



OVERHEAD SIGN STRUCTURE
 SPAN TYPE (STEEL)
 STRUCTURE DETAILS

STANDARD F17-01

Paul Kovacs
 APPROVED... CHIEF ENGINEER... DATE 5-20-2014

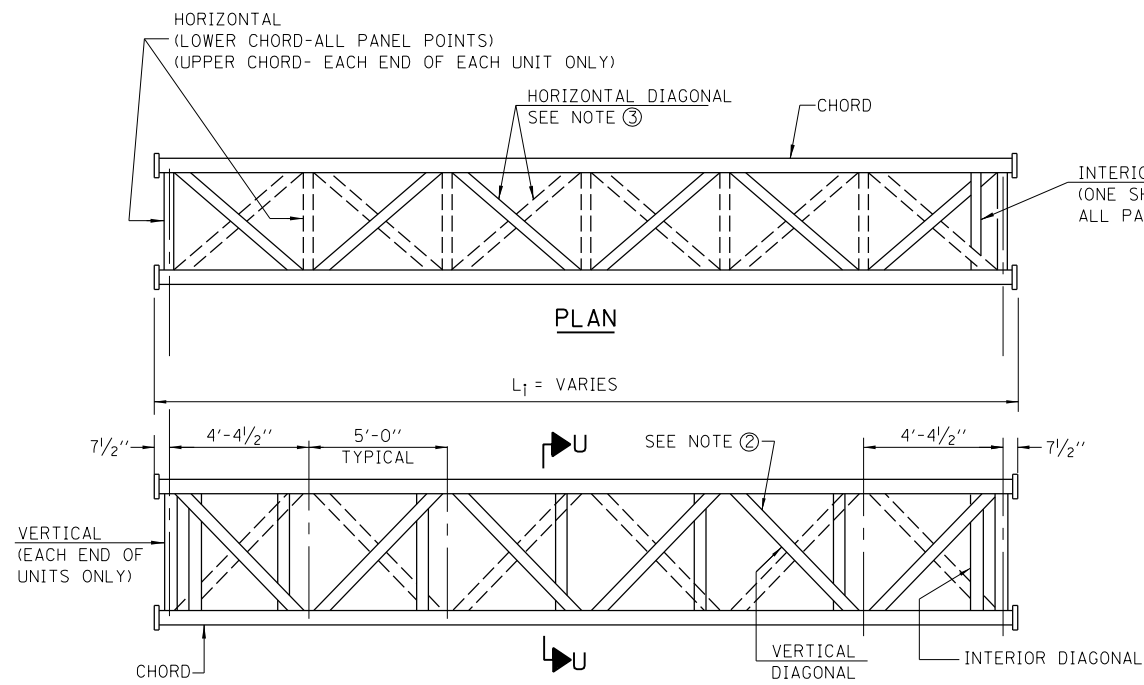

**ELEVATION
TYPICAL INTERIOR UNIT**

EVEN OR ODD NUMBER OF PANELS/EXTERIOR UNITS ALLOWED.

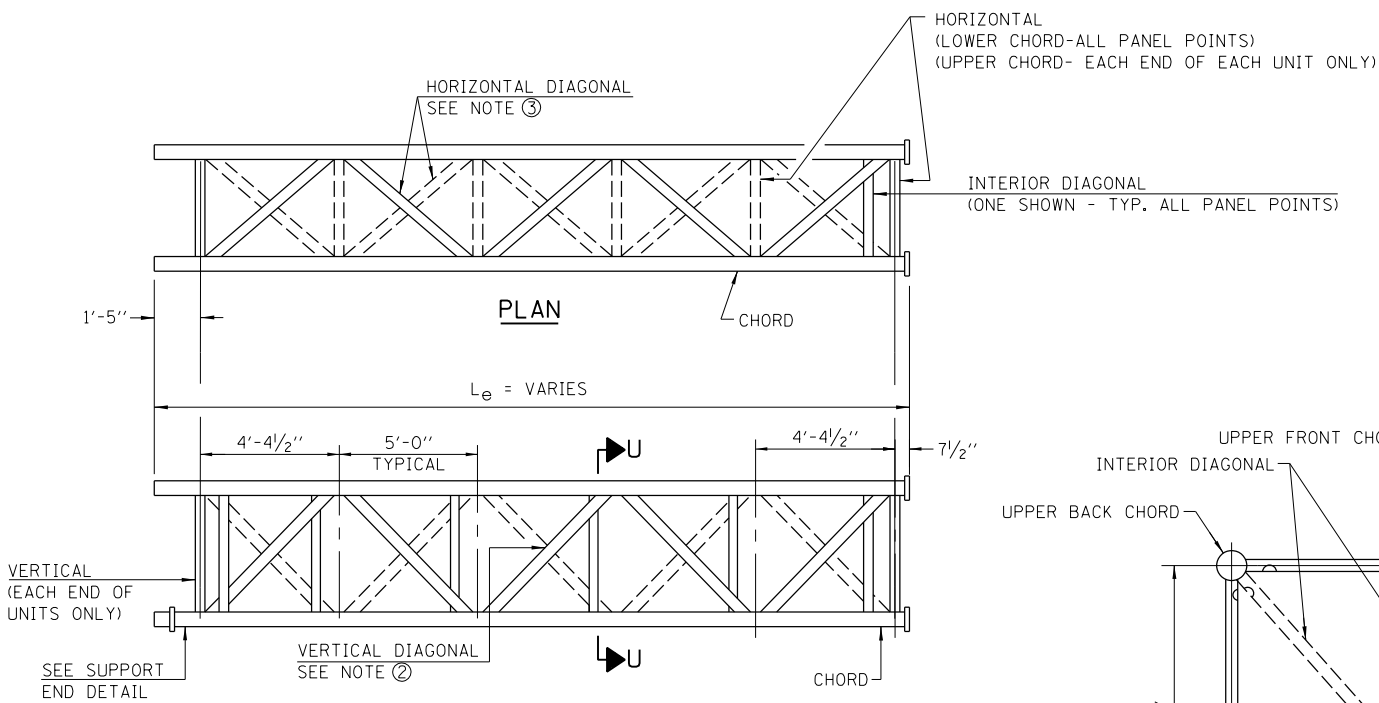

**ELEVATION
TYPICAL EXTERIOR UNIT**

EVEN OR ODD NUMBER OF PANELS/EXTERIOR UNITS ALLOWED.

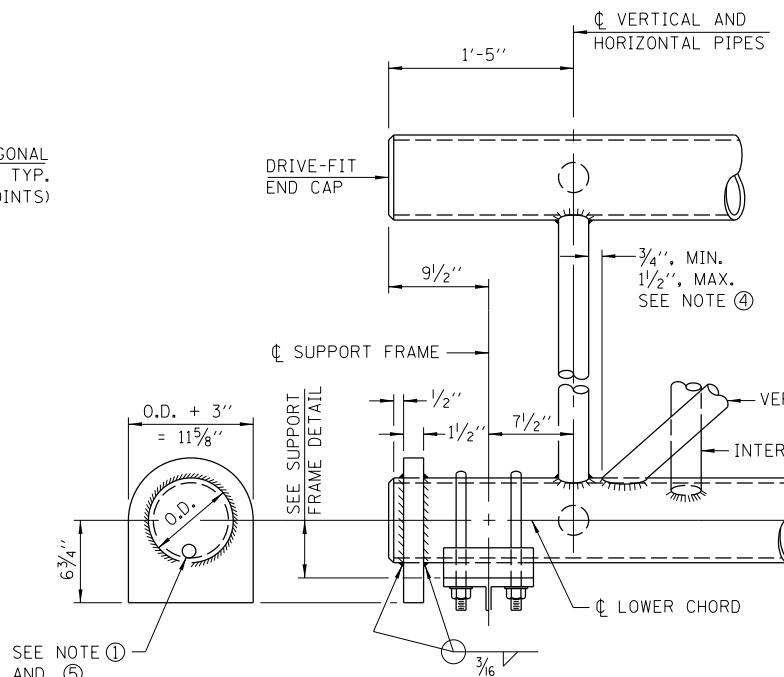

SUPPORT END DETAIL FOR EXTERIOR UNIT

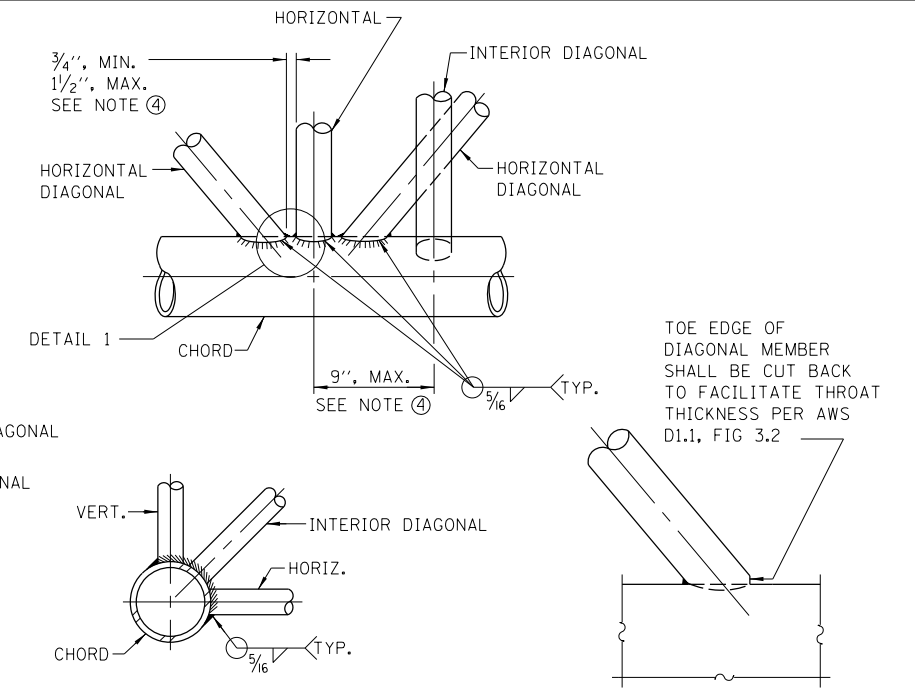

TYPICAL JOINT DETAILS

DETAIL 1

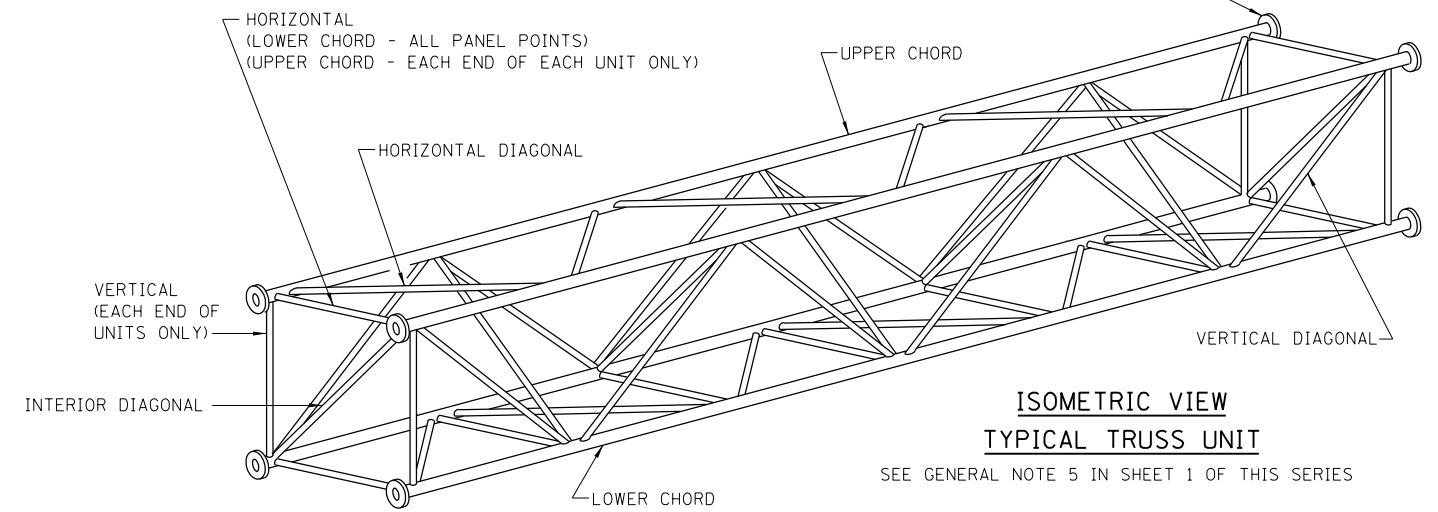

**ISOMETRIC VIEW
TYPICAL TRUSS UNIT**

SEE GENERAL NOTE 5 IN SHEET 1 OF THIS SERIES

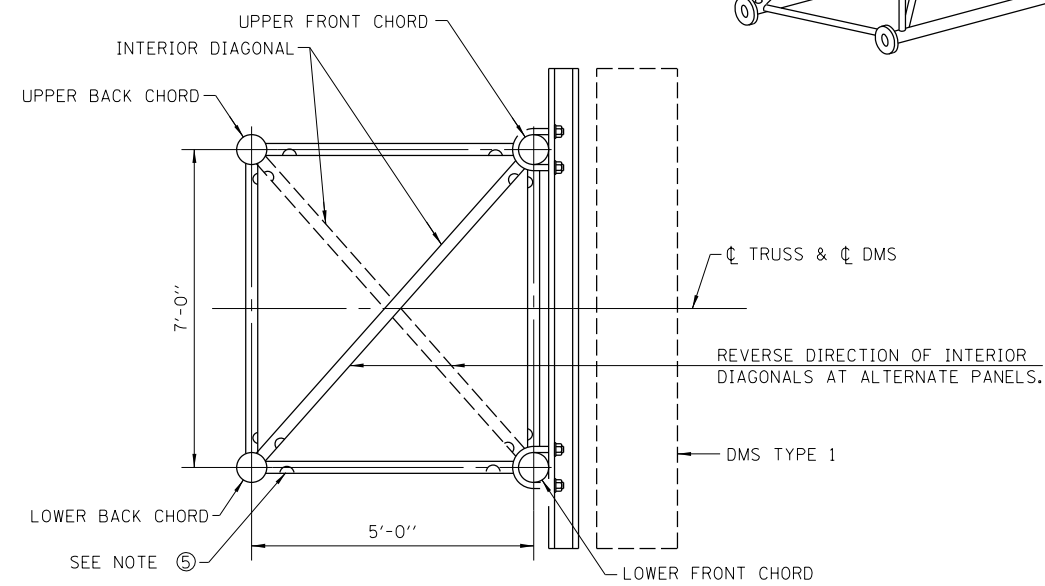

SECTION U-U

(VERTICAL AND HORIZONTAL DIAGONALS NOT SHOWN)

NOTES

- ① CONTRACTOR MUST USE STANDARD DRIVE-FIT CAP TO CLOSE END. 1/2" Ø DRAIN HOLE IN DRIVE-FIT CAP INSTALLED AFTER GALVANIZING. (TYP. AT NON-SPLICE ENDS OF CHORDS)
- ② VERTICAL DIAGONALS IN FRONT AND BACK FACE SHALL ALTERNATE INCLINATION.
- ③ HIDDEN LINES SHOW WIND BRACING ALTERNATES DIRECTION BETWEEN PLANES OF TOP AND BOTTOM CHORDS.
- ④ ALL DIAGONALS SHALL BE OFFSET FROM THE PANEL POINT BASED ON THE FOLLOWING: OFFSET SHALL PROVIDE A 3/4" MINIMUM TO 1 1/2" MAXIMUM CLEARANCE BETWEEN DIAGONAL AND ANY OTHER DIAGONAL, HORIZONTAL OR VERTICAL MEMBER, AND TO PROVIDE CLEARANCE FOR U-BOLT CONNECTIONS OF DMS TYPE 1 OR WALKWAY BRACKETS.
- ⑤ GALVANIZING VENT HOLES OF ADEQUATE SIZE SHALL BE PROVIDED ON UNDERSIDE AT EACH END OF TRUSS MEMBERS EXCEPT CHORDS. ALTERNATELY, HOLES MAY BE PROVIDED IN WALL OF CHORDS. ALL VENT HOLES SHALL BE DRILLED AND DE-BURRED, TYP.



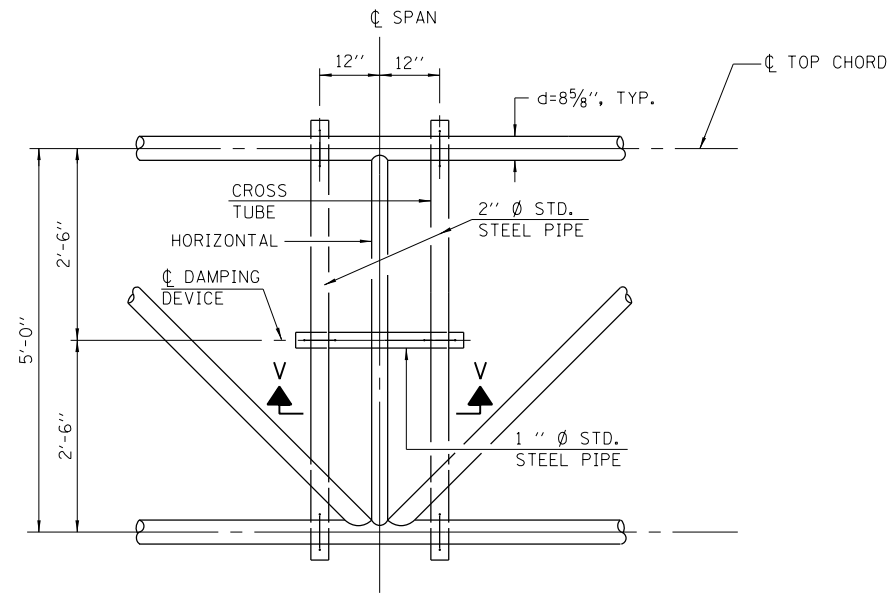

PLAN DETAIL
CL SPAN AT PANEL POINTS

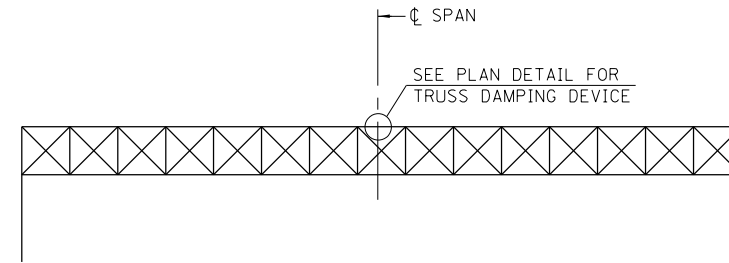

ELEVATION
STEEL OVERHEAD
SIGN TRUSS

DAMPER NOTE:

ONE DAMPER PER TRUSS. (31 LBS. STOCKBRIDGE-TYPE - 29" MINIMUM BETWEEN ENDS OF WEIGHTS)
COST INCLUDED IN "OVERHEAD SIGN STRUCTURE, SPAN TYPE (STEEL)".

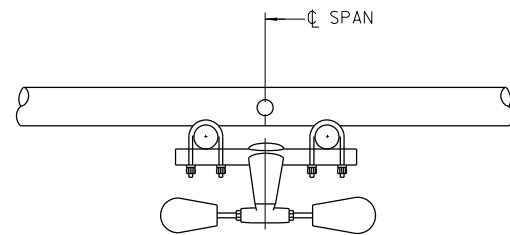

SECTION V-V

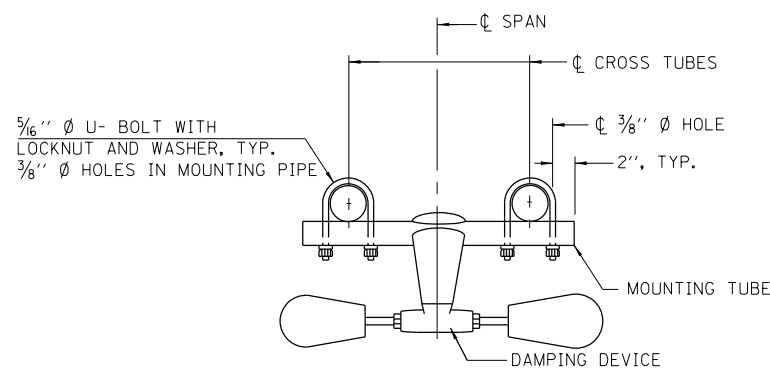

**TRUSS DAMPING
DEVICE CONNECTION DETAIL**
(TYPICAL)

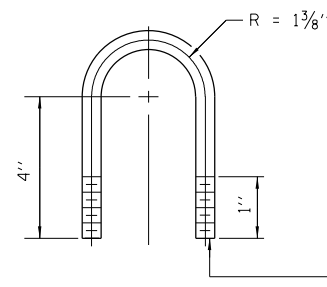

**DAMPING DEVICE MOUNTING
TUBE U-BOLT DETAIL**
(TYPICAL)

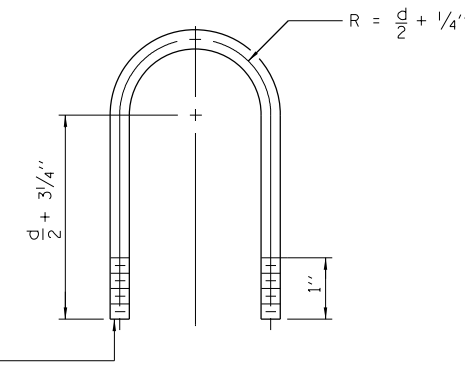

**TOP CHORD TO CROSS TUBE
U-BOLT DETAIL**
(TYPICAL)

Paul Kovacs
APPROVED..... CHIEF ENGINEER..... DATE 5-20-2014.



3/4" Ø U-BOLT.
 PROVIDE TWO WASHERS AND TWO
 HEXAGON LOCKNUTS. (4)
 1/8" X 2" SLOTS ON Ø POST.
 (4 SLOTS REQUIRED PER PIPE)

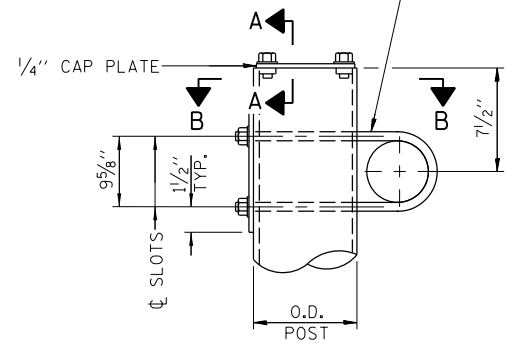

DETAIL A

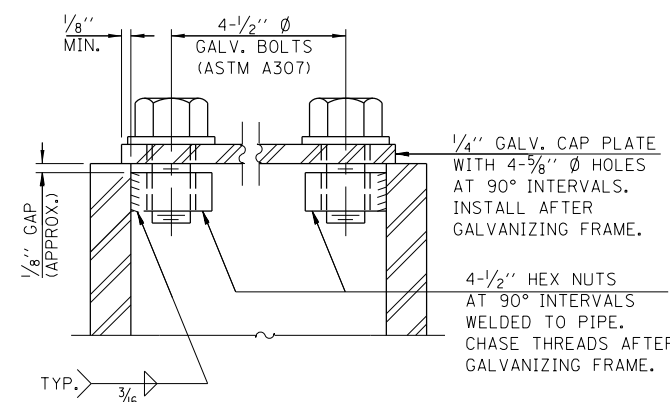

SECTION A-A

AS AN ALTERNATE TO BOLTS, MAY USE GALVANIZED
 DRIVE-FIT CAPS INSTALLED AFTER GALVANIZING FRAME.

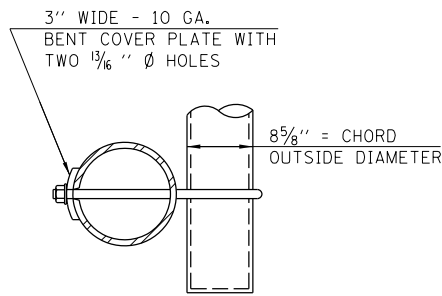

SECTION B-B

END SUPPORT SCHEDULE

DESIGN TRUSS TYPE	H OR H ₁	+	POSTS	DIAGONALS, STRUT
120-S	34' MAX.	1/2"	HSS 12.75x0.500	PIPE 5 X-STRONG
130-S	34' MAX.	1/2"	HSS 14x0.500	PIPE 5 XX-STRONG
140-S	34' MAX.	1/2"	HSS 14x0.500	PIPE 5 XX-STRONG
150-S	36' MAX.	1/2"	HSS 16x0.500	PIPE 5 XX-STRONG
160-S	36' MAX.	1/2"	HSS 16x0.500	PIPE 5 XX-STRONG

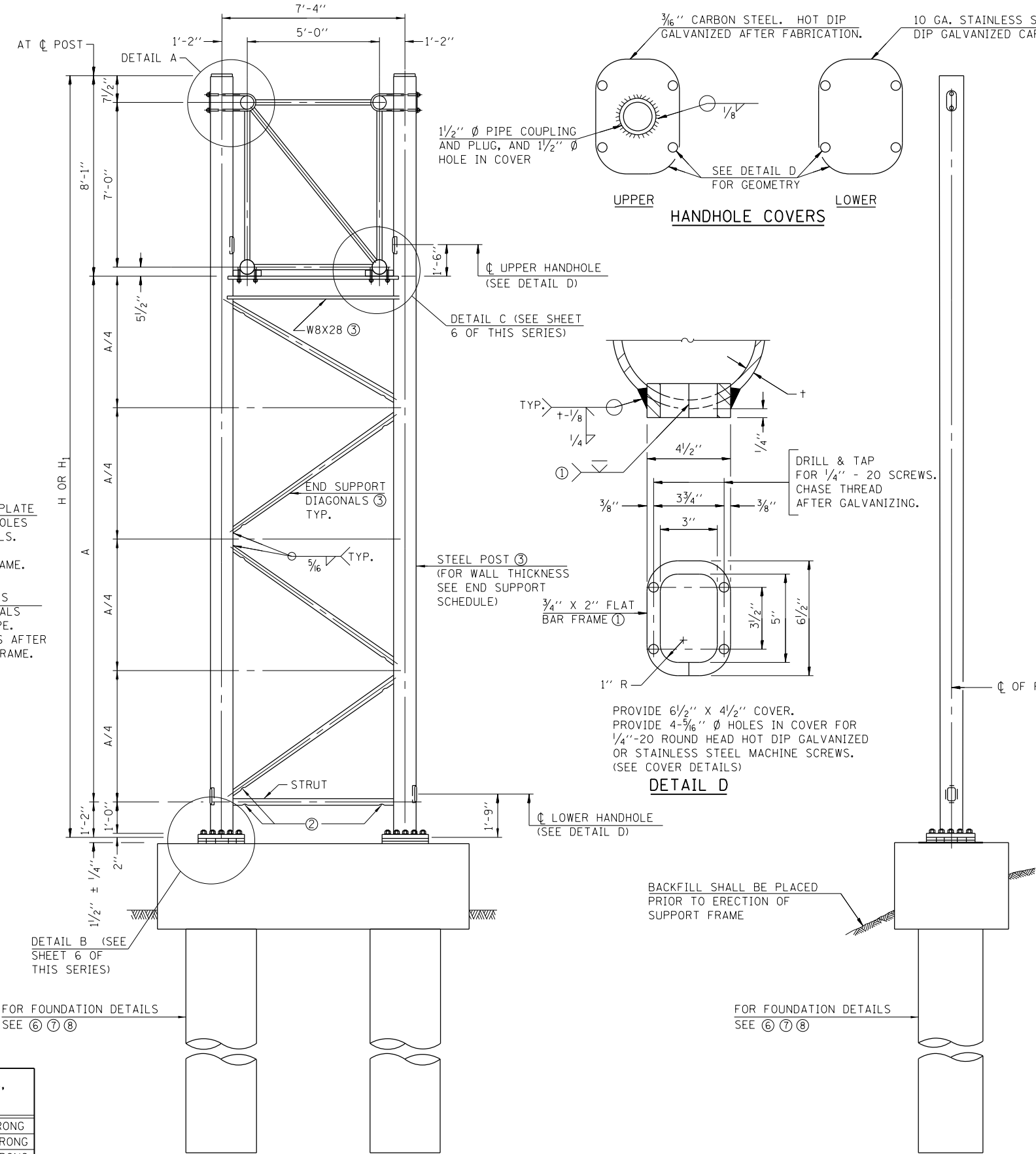

SIDE ELEVATION

END ELEVATION

END SUPPORT DETAILS

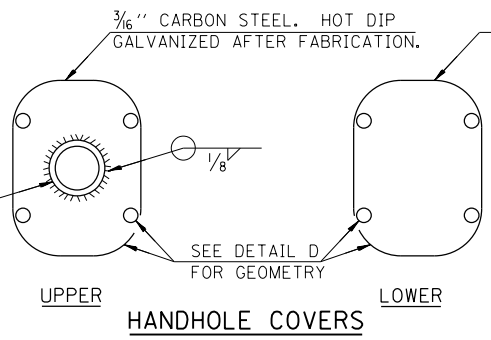

HANDHOLE COVERS

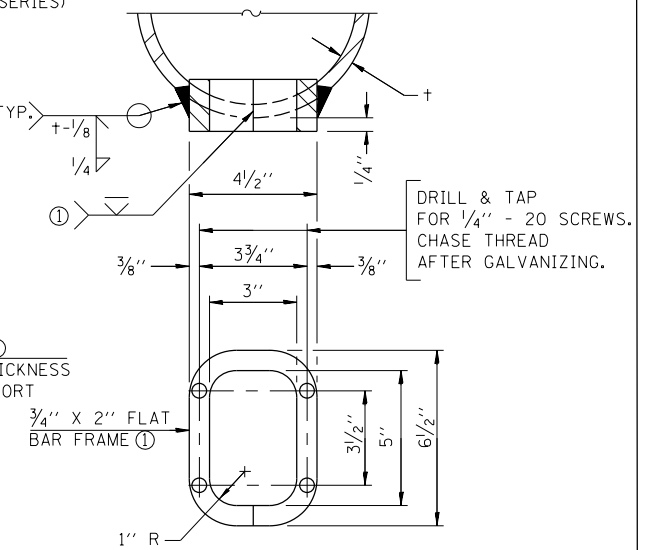

DETAIL D

NOTES:

- ① IN LIEU OF FABRICATED HANDHOLE FRAME AS SHOWN, MAY CUT FROM 2" PLATE (ROLLING DIRECTION VERTICAL). ALL CUT FACES TO BE GROUND TO ANSI ROUGHNESS OF 500 µIN OR LESS.
- ② GALVANIZING VENT HOLES OF ADEQUATE SIZE SHALL BE PROVIDED ON UNDERSIDE AT EACH END OF BRACING PIPES. ALTERNATELY, HOLES MAY BE PROVIDED IN WALL OF PIPE COLUMN. ALL VENT HOLES SHALL BE DRILLED AND DE-BURRED, TYP.
- ③ STEEL PIPE, PLATE, CARBON STEEL HANDHOLE COVERS AND ROLLED SECTIONS SHALL BE HOT DIP GALVANIZED AFTER FABRICATION. PAINTING IS NOT PERMITTED. SEE SHEET 1 OF THIS SERIES.
- ④ SEE GENERAL NOTES FOR FASTENERS.
- ⑤ NONSTANDARD APPLICATIONS MUST HAVE DIMENSIONS VERIFIED OR AMENDED AS APPROPRIATE.
- ⑥ SEE SHEET 7 OF THIS SERIES FOR SHOULDER TYPE FOUNDATION DETAILS.
- ⑦ SEE SHEET 8 OF THIS SERIES FOR MEDIAN BARRIER TYPE FOUNDATION DETAILS.
- ⑧ SEE SHEET 9 OF THIS SERIES FOR MEDIAN BARRIER TYPE FOUNDATION DETAILS WHEN EXISTING UTILITY IS PRESENT.

Paul Kovacs
 APPROVED... CHIEF ENGINEER... DATE 5-20-2014

OVERHEAD SIGN STRUCTURE
 SPAN TYPE (STEEL)
 STRUCTURE DETAILS
 STANDARD F17-01

HEXAGON LOCKNUT AND WASHER (TOP), LEVELING NUT AND WASHER (BOTTOM). GALVANIZE PER AASHTO M232. NUTS SHALL EACH BE TIGHTENED AGAINST BASE PLATE WITH 200 LB.-FT. MINIMUM TORQUE.

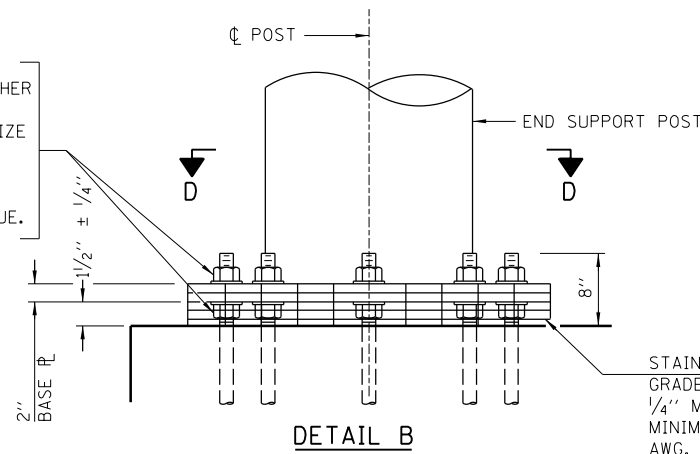

STAINLESS STEEL STANDARD GRADE WIRE CLOTH, 3" WIDE, 1/4" MAXIMUM OPENING WITH A MINIMUM WIRE DIAMETER OF AWG. NO. 16 WITH A MINIMUM 2" LAP. SECURE TO BASE PLATE AFTER ERECTION WITH 3/4" STAINLESS STEEL BANDING.

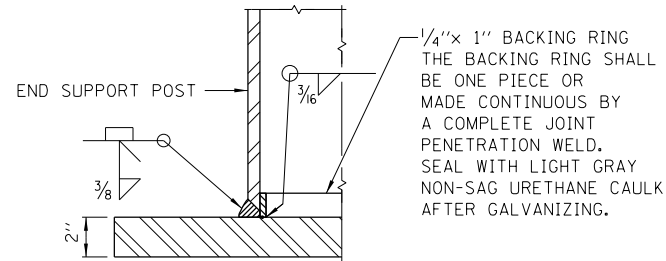

SECTION E-E

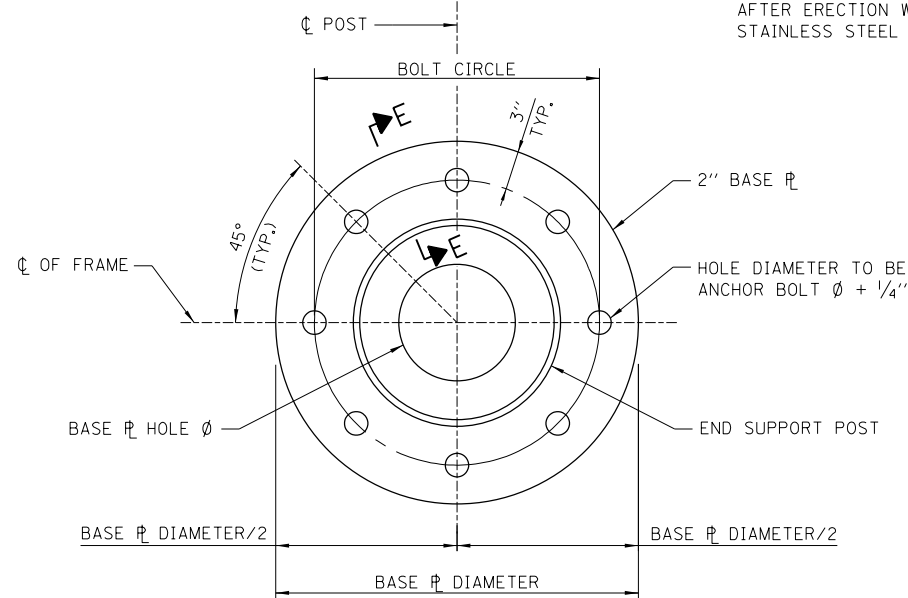

SECTION D-D

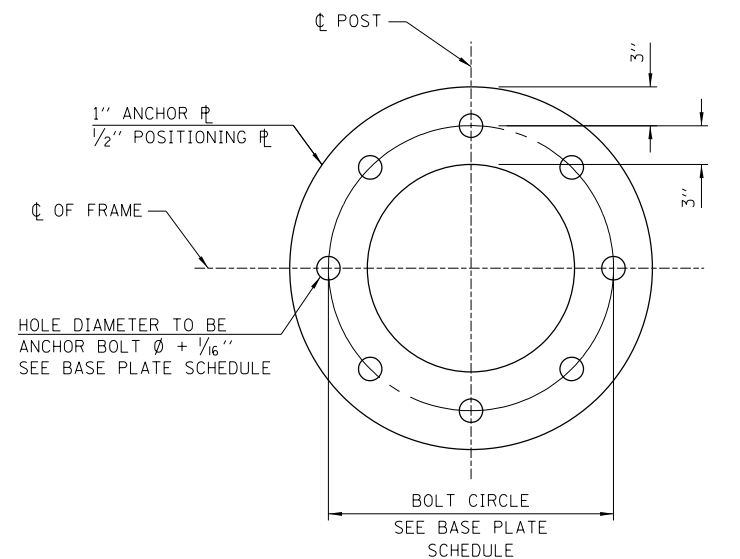

POSITIONING PLATE AND ANCHOR PLATE

UTILIZE 1/2" POSITIONING PLATE AND TEMPORARY NUTS WITH LEVELING NUTS OR OTHER ENGINEER APPROVED METHODS TO MAINTAIN ANCHOR BOLTS' ALIGNMENT DURING CONCRETE PLACEMENT. PLATE, EXTRA NUTS AND OTHER POSITIONING AIDS BECOME CONTRACTOR'S PROPERTY. COST INCLUDED IN "FOUNDATION FOR OVERHEAD STRUCTURE, SPAN TYPE (STEEL)".

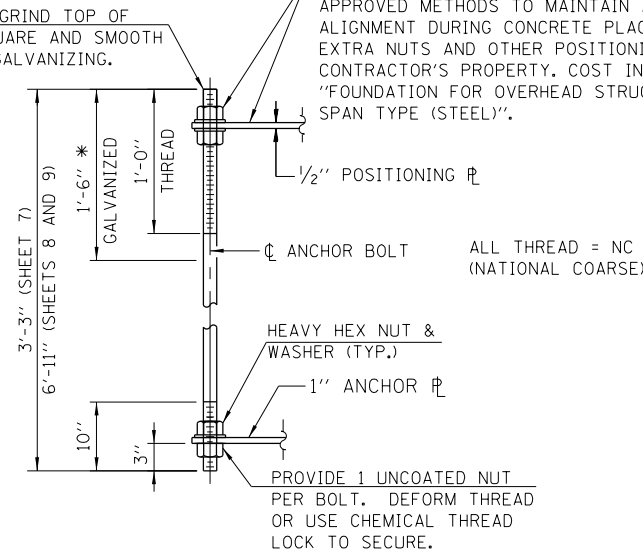

ANCHOR BOLT DETAIL

ANCHOR BOLTS SHALL CONFORM TO AASHTO M314 GRADE 105 AND MEET CHARPY V-NOTCH (CVN) ENERGY OF 15 LB.-FT. AT 40° F. GALVANIZE UPPER 18" PER AASHTO M232. NO WELDING SHALL BE PERMITTED ON BOLTS.

* 18" IS MINIMUM TO BE GALVANIZED. ENTIRE BOLT MAY BE GALVANIZED AT CONTRACTOR'S OPTION.

BASE PLATE SCHEDULE

DESIGN TRUSS TYPE	END SUPPORT POST OUTSIDE DIAMETER	BASE PLATE		BOLT CIRCLE	ANCHOR BOLT DIA.
		DIAMETER	HOLE Ø		
120-S	1'-0 3/4"	2'-0 3/4"	6.75"	1'-6 3/4"	1 1/2"
130-S	14"	2'-2"	8"	1'-8"	1 1/2"
140-S	14"	2'-2"	8"	1'-8"	1 1/2"
150-S	16"	2'-4"	8"	1'-10"	1 1/2"
160-S	16"	2'-4"	8"	1'-10"	1 3/4"

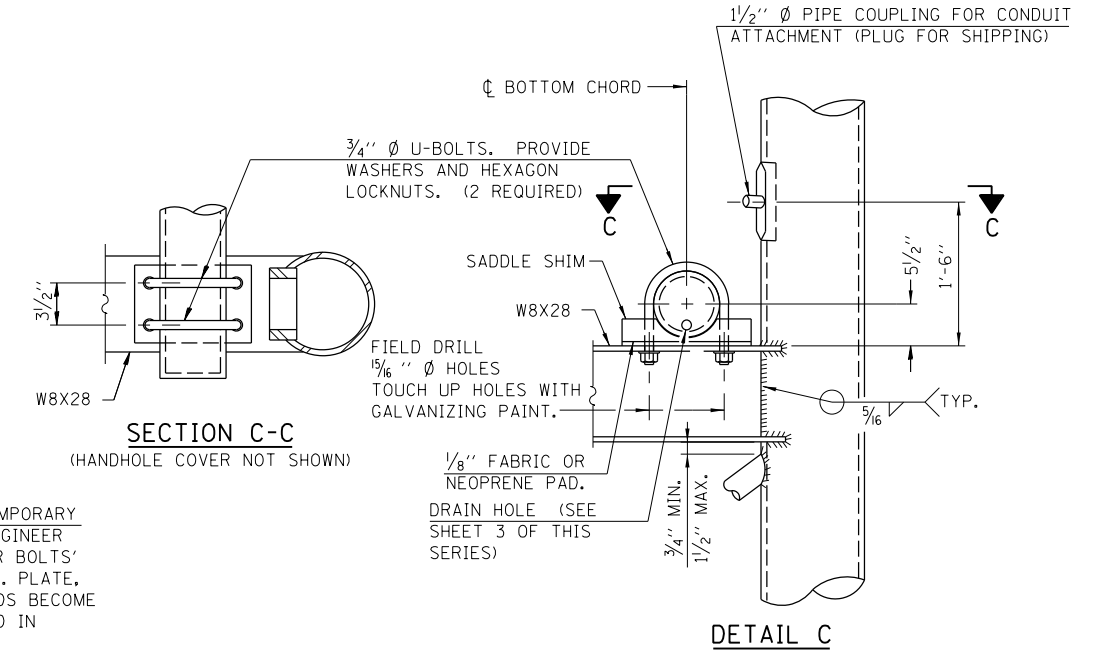

SECTION C-C

(HANDHOLE COVER NOT SHOWN)

DETAIL C

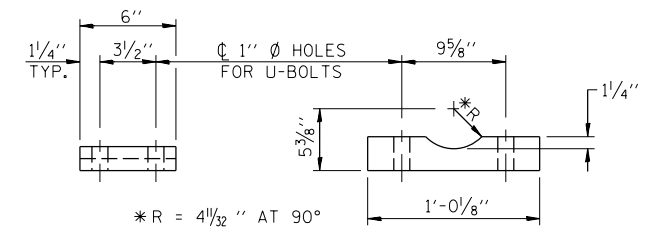

SADDLE SHIM DETAIL



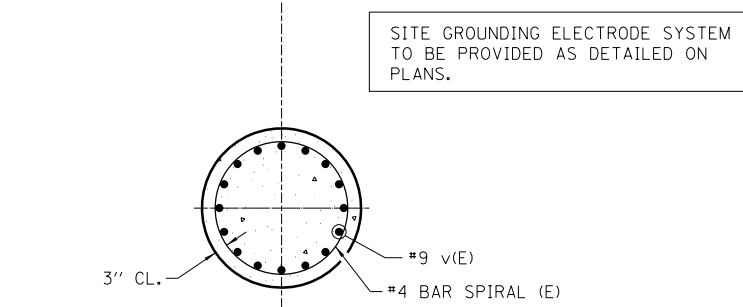
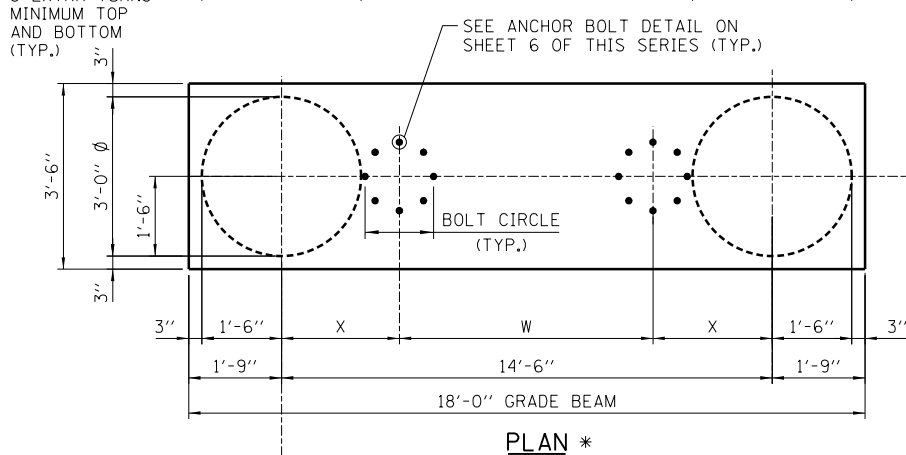
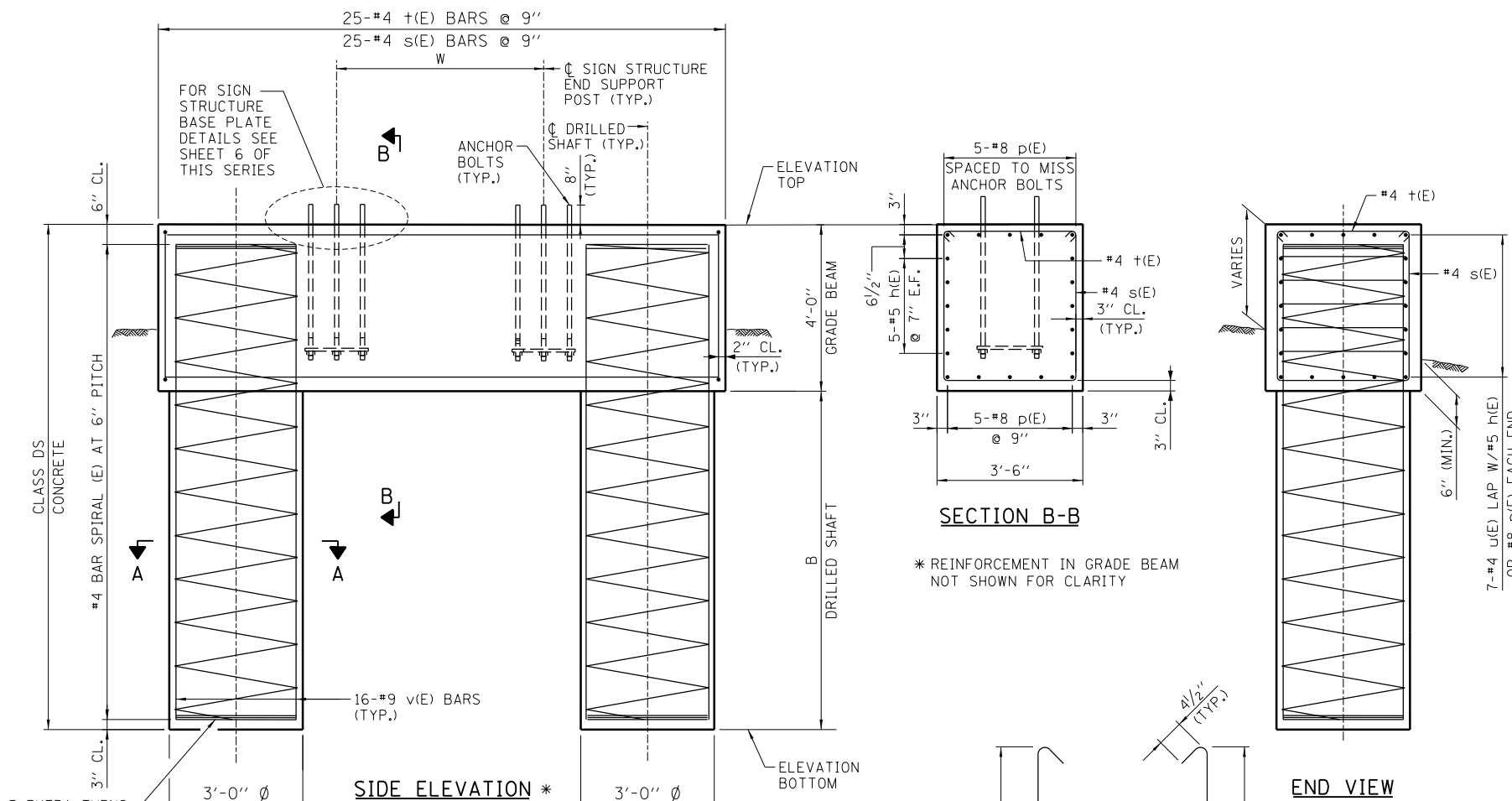

APPROVED: *Paul Kovacs* CHIEF ENGINEER DATE 5-20-2014

NOTES:

1. THE FOUNDATION DETAILS SHOWN ARE BASED ON THE PRESENCE OF MOSTLY COHESIVE SOIL CONDITIONS (SILTY OR SANDY CLAY), WITH AN AVERAGE UNCONFINED COMPRESSIVE STRENGTH (QU) > 1.25 TON/SQ. FT. WHICH MUST BE DETERMINED BY PREVIOUS SOIL INVESTIGATIONS AT THE JOBSITE. WHEN OTHER CONDITIONS ARE INDICATED, THE BORING DATA SHALL BE INCLUDED IN THE PLANS AND THE FOUNDATION DIMENSIONS SHOWN SHALL BE THE RESULT OF SITE SPECIFIC DESIGNS. IF CONDITIONS ENCOUNTERED IN THE FIELD ARE DIFFERENT THAN THOSE INDICATED, THE CONTRACTOR SHALL NOTIFY THE ENGINEER TO DETERMINE IF THE FOUNDATION DIMENSIONS NEED TO BE MODIFIED.
2. ALL MATERIAL, FABRICATION, AND CONSTRUCTION REQUIREMENTS SHALL BE IN ACCORDANCE WITH SECTION 734 OF THE ILLINOIS TOLLWAY SUPPLEMENTAL SPECIFICATIONS.
3. CONCRETE SHALL BE PLACED MONOLITHICALLY, WITHOUT CONSTRUCTION JOINTS UNLESS NOTED OTHERWISE.
4. BACKFILL SHALL BE PLACED PER SECTION 502 OF THE STANDARD SPECIFICATION AND PRIOR TO ERECTION OF END SUPPORT POST.
5. PROVIDE NORMAL SURFACE FINISH, FOLLOWED BY CONCRETE SEALER APPLICATION ON ALL CONCRETE SURFACES EXCEPT BOTTOM OF GRADE BEAM AND DRILLED SHAFTS. COST INCLUDED IN THE COST OF "FOUNDATION FOR OVERHEAD SIGN STRUCTURE, SPAN TYPE".
6. ALL REBAR DESIGNATED (E) SHALL BE EPOXY COATED, REBAR SHALL BE POSITIONED SO THAT THERE WILL BE NO INTERFERENCE BETWEEN VERTICAL REINFORCEMENT AND ANCHOR BOLTS.
7. FURNISHING AND INSTALLING ALL CONDUIT, FITTINGS AND GROUNDING SYSTEM IS INCLUDED IN THE COST OF "FOUNDATION FOR OVERHEAD SIGN STRUCTURE, SPAN TYPE".
8. NO SONOTUBES OR DECOMPOSABLE FORMS SHALL BE USED 6" BELOW THE FINISHED GROUND LINE. PERMANENT METAL FORMS OR OTHER SHIELDING MAY NOT BE LEFT IN PLACE BELOW THE ELEVATION WITHOUT THE ENGINEER'S WRITTEN PERMISSION. EXCAVATIONS SHALL BE DEWATERED BEFORE CONCRETE PLACEMENT IF DIRECTED BY THE ENGINEER AT NO ADDITION COST.
9. IF NECESSARY TO INCREASE STEEL END SUPPORT HEIGHT ABOVE THE LIMITATIONS SHOWN IN SIGN STRUCTURE MEMBER SCHEDULE ON SHEET 5 OF THIS SERIES, GRADE BEAM DEPTH ON THIS SHEET MAY BE INCREASED UP TO 6'-0" WITHOUT CHANGES TO THE DRILLED SHAFT DESIGN. GRADE BEAM REINFORCEMENT, CONCRETE VOLUME AND LENGTH OF ANCHOR BOLTS SHALL BE REVISED ACCORDINGLY.

* REINFORCEMENT IN GRADE BEAM NOT SHOWN FOR CLARITY

BAR LIST - EACH FOUNDATION
(2 SHAFT AND 1 GRADE BEAM)

BAR	NUMBER	SIZE	LENGTH	SHAPE
h(E)	10	#5	17'-8"	—
p(E)	10	#8	17'-8"	—
s(E)	25	#4	11'-1"	⌈
t(E)	25	#4	3'-11"	⌋
u(E)	14	#4	7'-0"	⌋
v(E)	32	#9	F LESS 9"	—

#4 BAR SPIRAL (E) - SEE SIDE ELEVATION

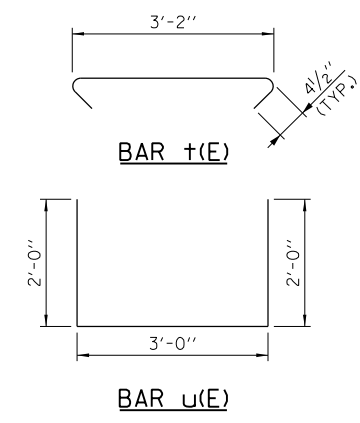

SHOULDER FOUNDATION SCHEDULE

DESIGN TRUSS TYPE	W	X	B	CLASS DS CONCRETE (CU YD)	REINFORCEMENT BARS (POUNDS)
120-S	7'-4"	3'-7"	50'-0"	35.5	7930
130-S	7'-4"	3'-7"	55'-0"	38.1	8570
140-S	7'-4"	3'-7"	55'-0"	38.1	8570
150-S	7'-4"	3'-7"	55'-0"	38.1	8570
160-S	7'-4"	3'-7"	55'-0"	38.1	8570



OVERHEAD SIGN STRUCTURE
SPAN TYPE (STEEL)
STRUCTURE DETAILS

STANDARD F17-01

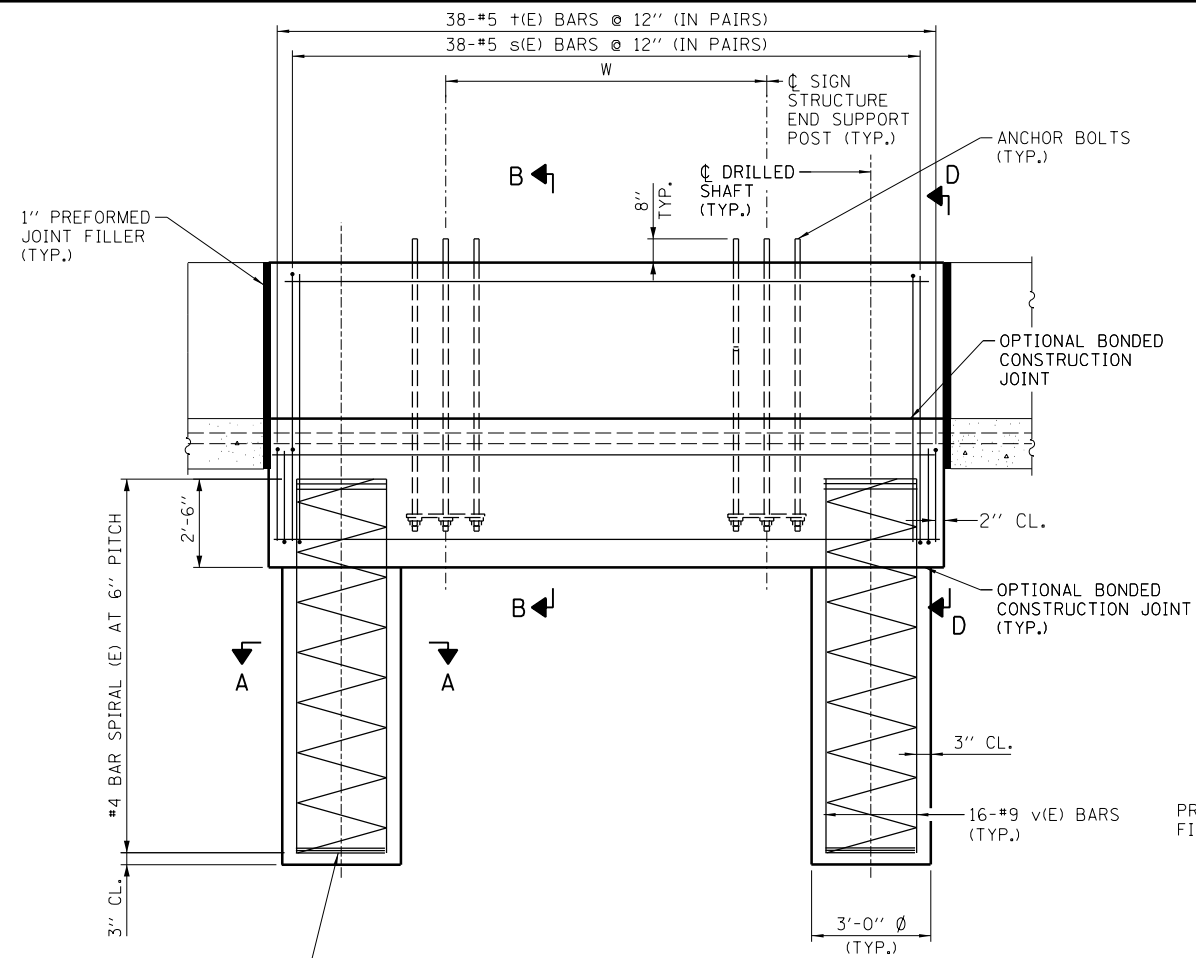

SIDE ELEVATION *

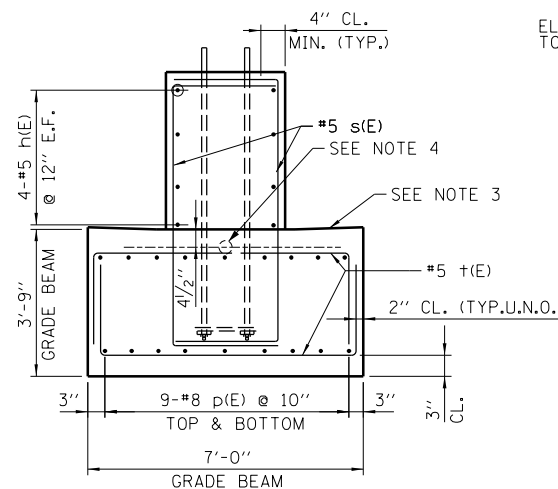

SECTION B-B

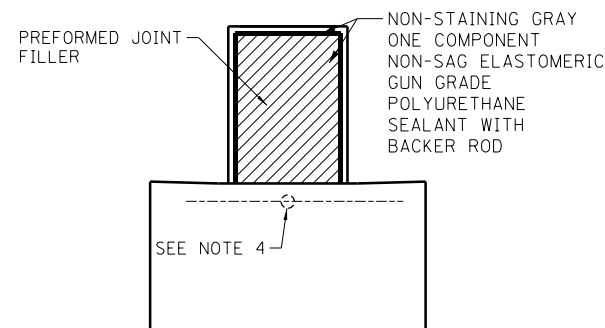

SECTION D-D

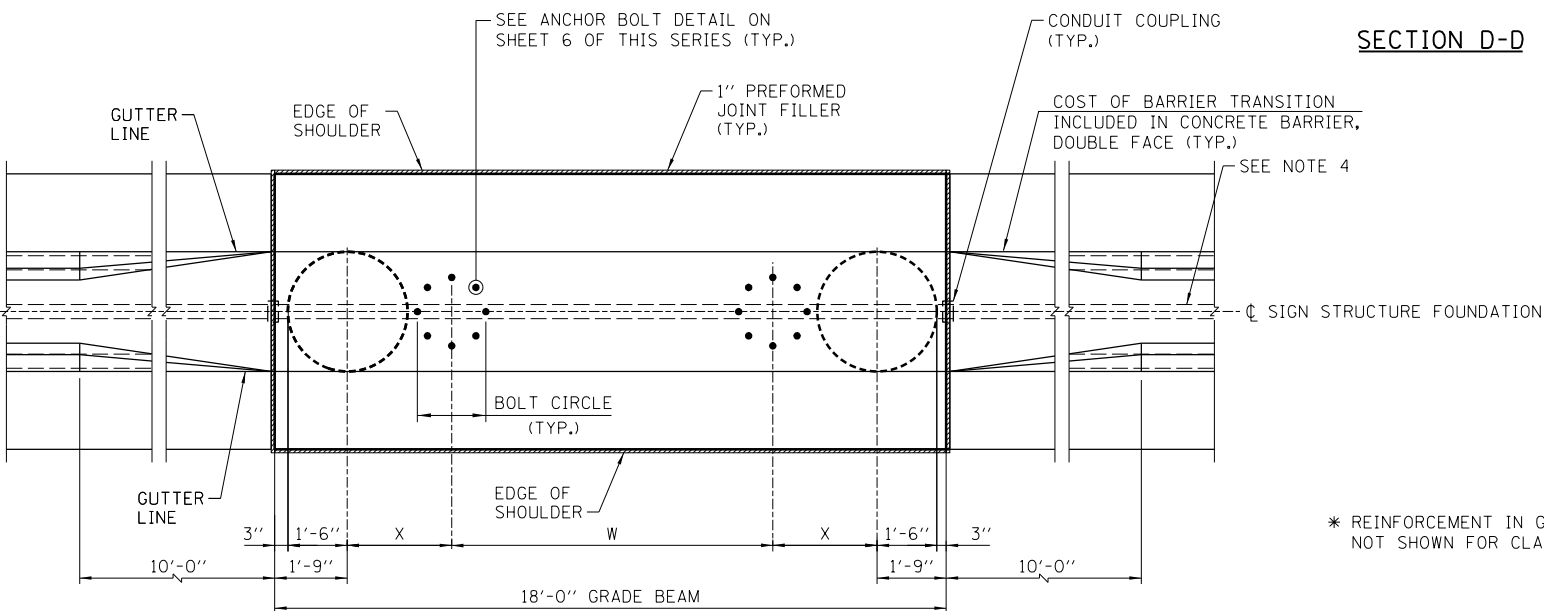

PLAN *

* REINFORCEMENT IN GRADE BEAM NOT SHOWN FOR CLARITY

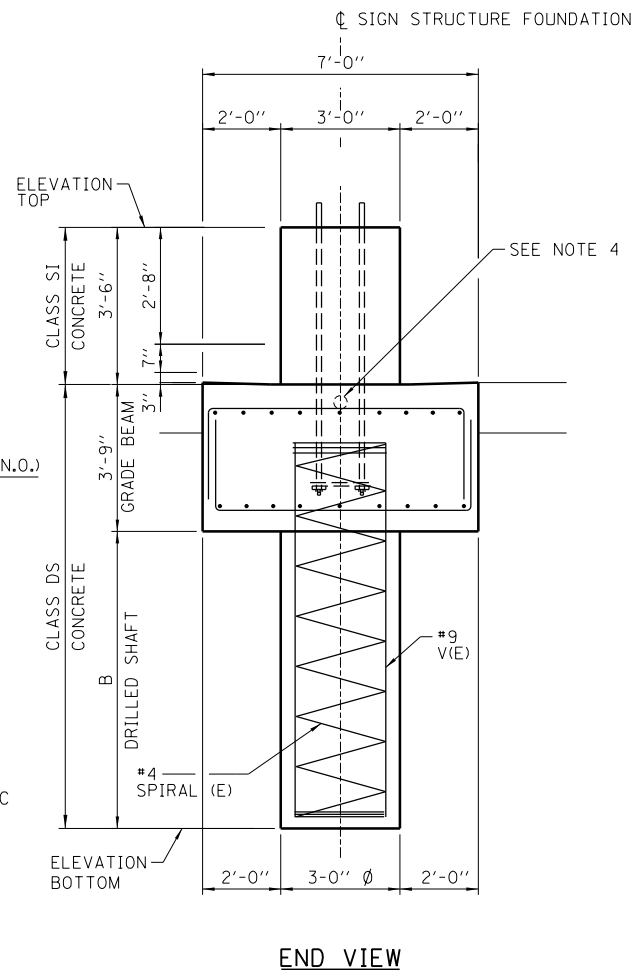

END VIEW

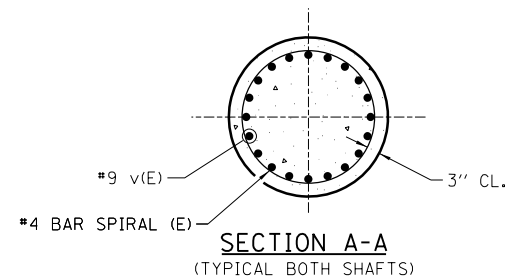

SECTION A-A
(TYPICAL BOTH SHAFTS)

BAR LIST - EACH FOUNDATION

BAR	NUMBER	SIZE	LENGTH	SHAPE
h(E)	8	#5	17'-8"	—
p(E)	18	#8	17'-8"	—
s(E)	38	#5	11'-3"	C
t(E)	38	#5	11'-10"	U
v(E)	40	#9	B ADD 2'-3"	—

#4 BAR SPIRAL (E) - SEE SIDE ELEVATION

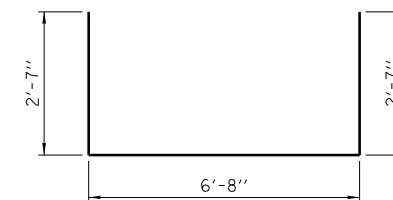

BAR t(E)

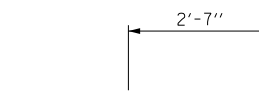

BAR s(E)

MEDIAN BARRIER FOUNDATION SCHEDULE

DESIGN TRUSS TYPE	W	X	B	CLASS SI CONCRETE (CU YD)	CLASS DS CONCRETE (CU YD)	REINFORCEMENT BARS (POUNDS)	PROTECTIVE COAT (SQ YD)
120-S	7'-4"	3'-7"	55'-0"	7.0	46.3	10970	28.0
130-S	7'-4"	3'-7"	55'-0"	7.0	46.3	10970	28.0
140-S	7'-4"	3'-7"	60'-0"	7.0	48.9	12850	28.0
150-S	7'-4"	3'-7"	65'-0"	7.0	51.5	13630	28.0
160-S	7'-4"	3'-7"	65'-0"	7.0	51.5	13630	28.0

NOTES:

- SEE SHEET 7 OF THIS SERIES FOR FOUNDATION NOTES AND DESIGN CRITERIA.
- FOR SIGN STRUCTURE BASE PLATE DETAIL, SEE SHEET 6 OF THIS SERIES.
- REFERENCE ILLINOIS TOLLWAY STANDARD DRAWING C5 FOR GUTTER SLOPE.
- COORDINATE CONDUIT SIZE, LOCATION AND QUANTITY WITH ELECTRICAL PLANS. CONDUITS SHALL BE PLACED TO MISS REINFORCEMENT BARS. DO NOT CUT REINFORCEMENT BARS.
- PROTECTIVE COAT SHALL BE APPLIED TO THE TRAFFIC AND TOP FACES OF BARRIER AND TOP FACE OF GUTTER.



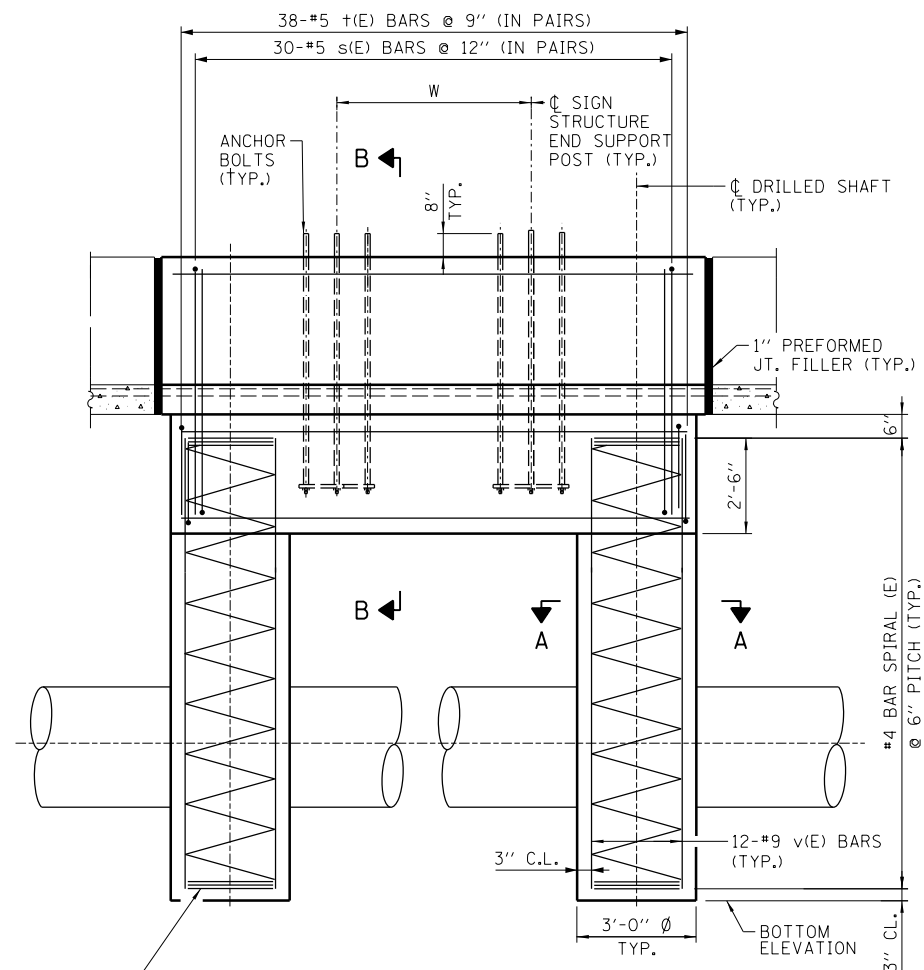

3 EXTRA TURNS
MINIMUM TOP
AND BOTTOM
(TYP.)

SIDE ELEVATION *

* REINFORCEMENT IN GRADE BEAM
NOT SHOWN FOR CLARITY

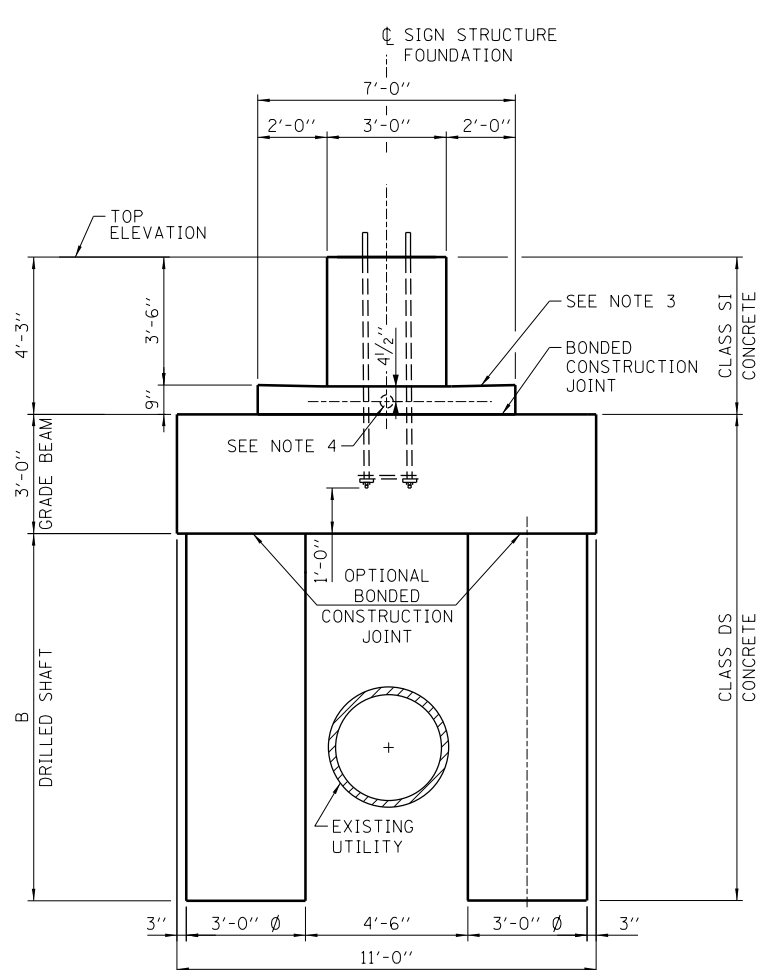

END VIEW

BAR LIST - EACH FOUNDATION

BAR NUMBER	SIZE	LENGTH	SHAPE
h(E) 16	#5	13'-8"	—
p(E) 30	#8	13'-8"	—
s(E) 30	#5	11'-3"	C
t(E) 15	#5	6'-8"	—
+1(E) 38	#8	15'-10"	—
v(E) 48	#9	B ADD 2'-3"	—

#4 BAR SPIRAL (E) - SEE SIDE ELEVATION

MEDIAN BARRIER FOUNDATION SCHEDULE

DESIGN TRUSS TYPE	W	X	B	CLASS SI CONCRETE (CU YD)	CLASS DS CONCRETE (CU YD)	REINFORCEMENT BARS (POUNDS)	PROTECTIVE COAT (SQ YD)
120-S	7'-4"	1'-7"	40'-0"	8.2	59.0	12170	22.0
130-S	7'-4"	1'-7"	40'-0"	8.2	59.0	12170	22.0
140-S	7'-4"	1'-7"	45'-0"	8.2	64.2	13200	22.0
150-S	7'-4"	1'-7"	50'-0"	8.2	69.5	14220	22.0
160-S	7'-4"	1'-7"	50'-0"	8.2	69.5	14220	22.0

SITE GROUNDING ELECTRODE SYSTEM
TO BE PROVIDED AS DETAILED ON
PLANS.

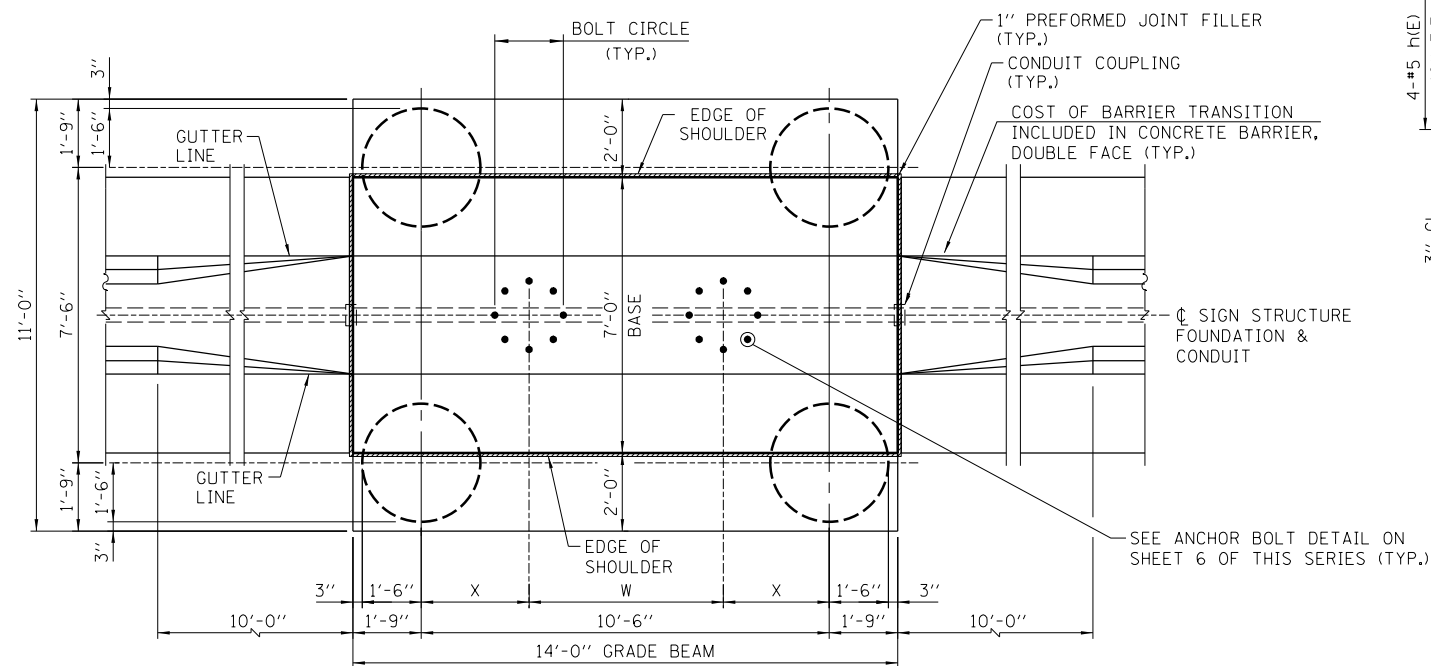

PLAN *

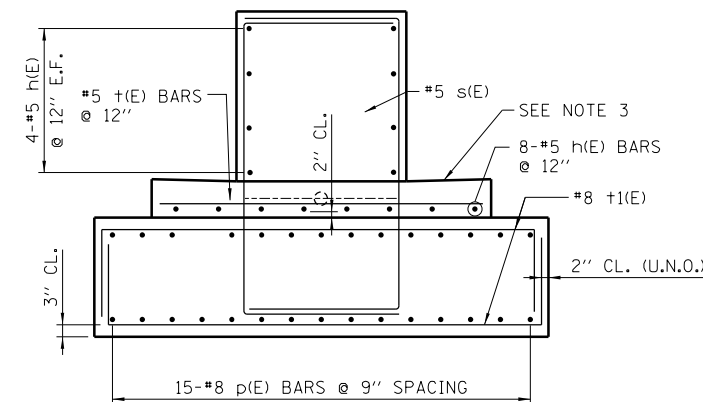

SECTION B-B

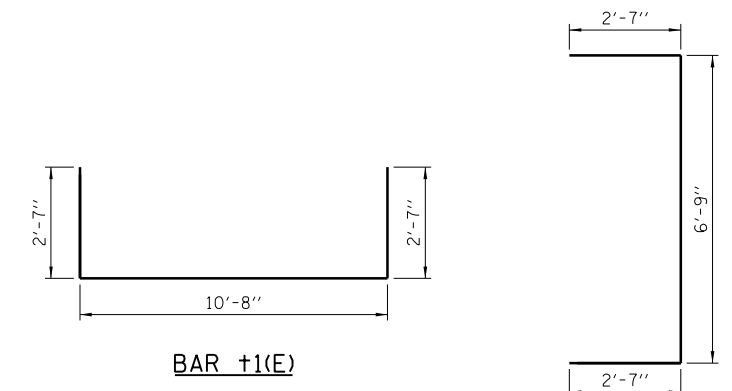

BAR #1(E)

BAR #S(E)

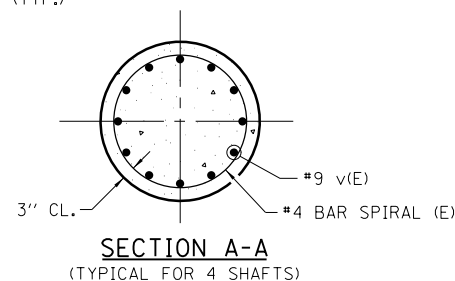

SECTION A-A
(TYPICAL FOR 4 SHAFTS)

NOTES:

- SEE SHEET 7 FOR FOUNDATION NOTES AND DESIGN CRITERIA.
- FOR SIGN STRUCTURE BASE PLATE DETAIL, SEE SHEET 6 OF THIS SERIES.
- REFERENCE ILLINOIS TOLLWAY STANDARD DRAWING C5 FOR GUTTER SLOPE.
- COORDINATE CONDUIT SIZE, LOCATION AND QUANTITY WITH ELECTRICAL PLANS. CONDUITS SHALL BE PLACED TO MISS REINFORCEMENT BARS. DO NOT CUT REINFORCEMENT BARS.
- PROTECTIVE COAT SHALL BE APPLIED TO THE TRAFFIC AND TOP FACES OF BARRIER AND TOP FACE OF GUTTER.



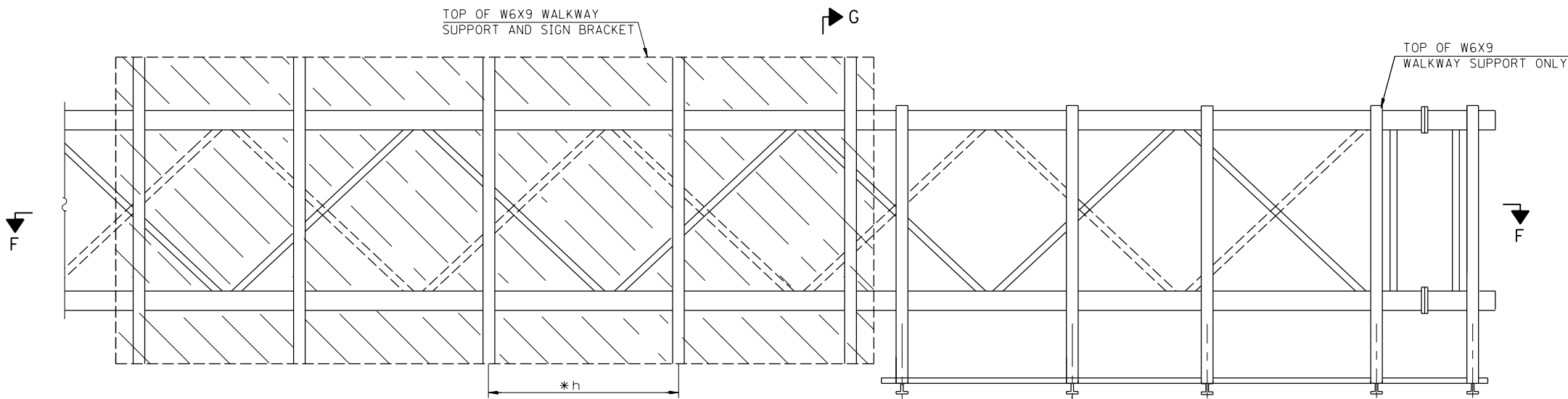

WALKWAY AND TRUSS GRATING WIDTH DIMENSIONS ARE NOMINAL AND MAY VARY $\pm 1/2$ " BASED ON AVAILABLE STANDARD WIDTHS.

TYPICAL FRONT ELEVATION
WITH HANDRAIL OMITTED FOR CLARITY.

BRACKET AND GRATING DIMENSIONS ARE NOMINAL AND WILL VARY BASED ON ACTUAL DMS DIMENSIONS PLUS MANUFACTURER'S MOUNTING DEVICES.

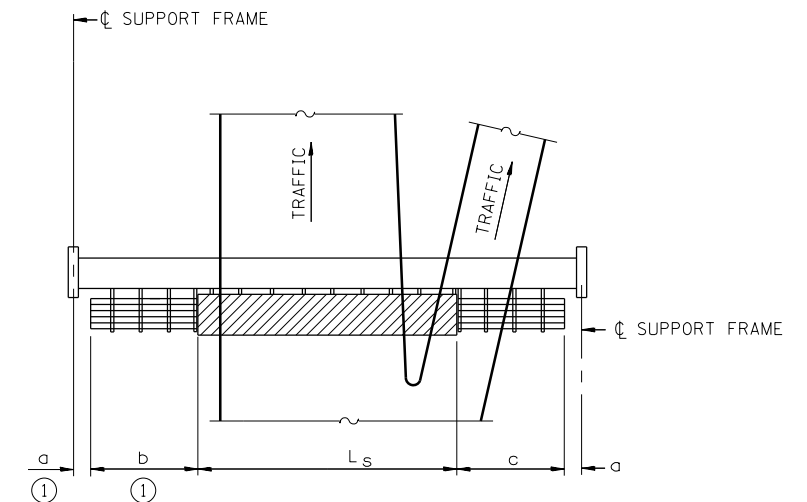

PLAN
WALKWAY AND HANDRAIL SKETCH
(ROAD PLAN BENEATH TRUSS VARIES)

BRACKET TABLE

SIGN WIDTH		NUMBER BRACKETS REQUIRED
GREATER THAN	LESS THAN OR EQUAL TO	
	8'-0"	2
8'-0"	14'-0"	3
14'-0"	20'-0"	4
20'-0"	26'-0"	5
26'-0"	32'-0"	6

NOTES:

- * SPACE W6X9 WALKWAY BRACKETS AND SIGN BRACKETS FOR EFFICIENCY AND WITHIN LIMITS SHOWN:
 $f = 12$ " MAXIMUM, 4 " MINIMUM (END OF SIGN TO ϕ OF NEAREST BRACKET)
 $g = 12$ " MAXIMUM, 4 " MINIMUM (END OF WALKWAY GRATING TO ϕ OF NEAREST SUPPORT BRACKET)
 $h = 6$ '- 0 " MAXIMUM (ϕ TO ϕ SIGN AND/OR WALKWAY SUPPORT BRACKETS, W6X9)
- ** MAXIMUM DMS WEIGHT = 5000 LBS. 4 '- 2 " MAXIMUM THICKNESS INCLUDES THICKNESS OF DMS TYPE 1 PLUS CONNECTION TO W6X9.

FOR SECTION G-G AND GRATING SPLICE DETAILS, SEE SHEET 11 OF THIS SERIES. FOR HANDRAIL SPLICE DETAILS, SEE SHEET 12 OF THIS SERIES.

TRUSS GRATING TO FACILITATE INSPECTION SHALL RUN FULL LENGTH (CENTER TO CENTER OF SUPPORT FRAMES) ± 12 " ON OVERHEAD TRUSSES. COST OF TRUSS GRATING IS INCLUDED IN "OVERHEAD SIGN STRUCTURE, SPAN TYPE (STEEL)".

- ① IF WALKWAY IS REQUIRED LEFT OF THE DMS, $a = 1$ '- 6 " AND $b =$ WALKWAY LENGTHS. IF WALKWAY IS NOT REQUIRED LEFT OF THE DMS, $b = 0$ AND " a " IS DIMENSION FROM LEFT SUPPORT FRAME TO LEFT END OF DMS.

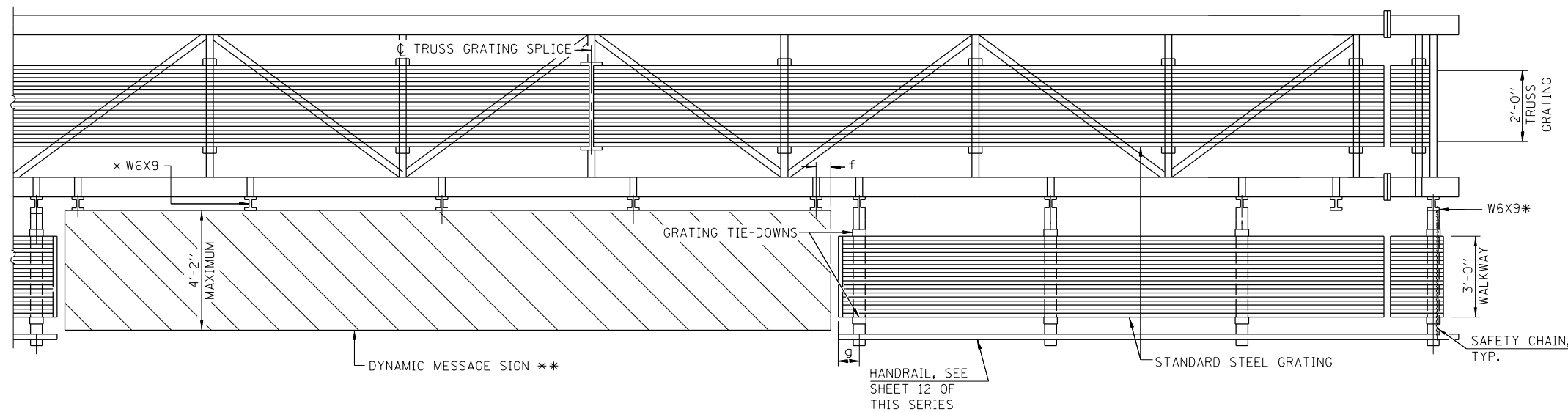

SECTION F-F

HANDRAIL AND WALKWAY SHALL SPAN A MINIMUM OF THREE BRACKETS BETWEEN SPLICES AND/OR GAP JOINTS. PLACE ALL SIGN AND WALKWAY BRACKETS AS CLOSE TO PANEL POINTS AS PRACTICAL. GRATING AND HANDRAIL SPLICES PLACED AS NEEDED.



OVERHEAD SIGN STRUCTURE
SPAN TYPE (STEEL)
STRUCTURE DETAILS

STANDARD F17-01

APPROVED: *Paul Kovacs* CHIEF ENGINEER DATE 5-20-2014

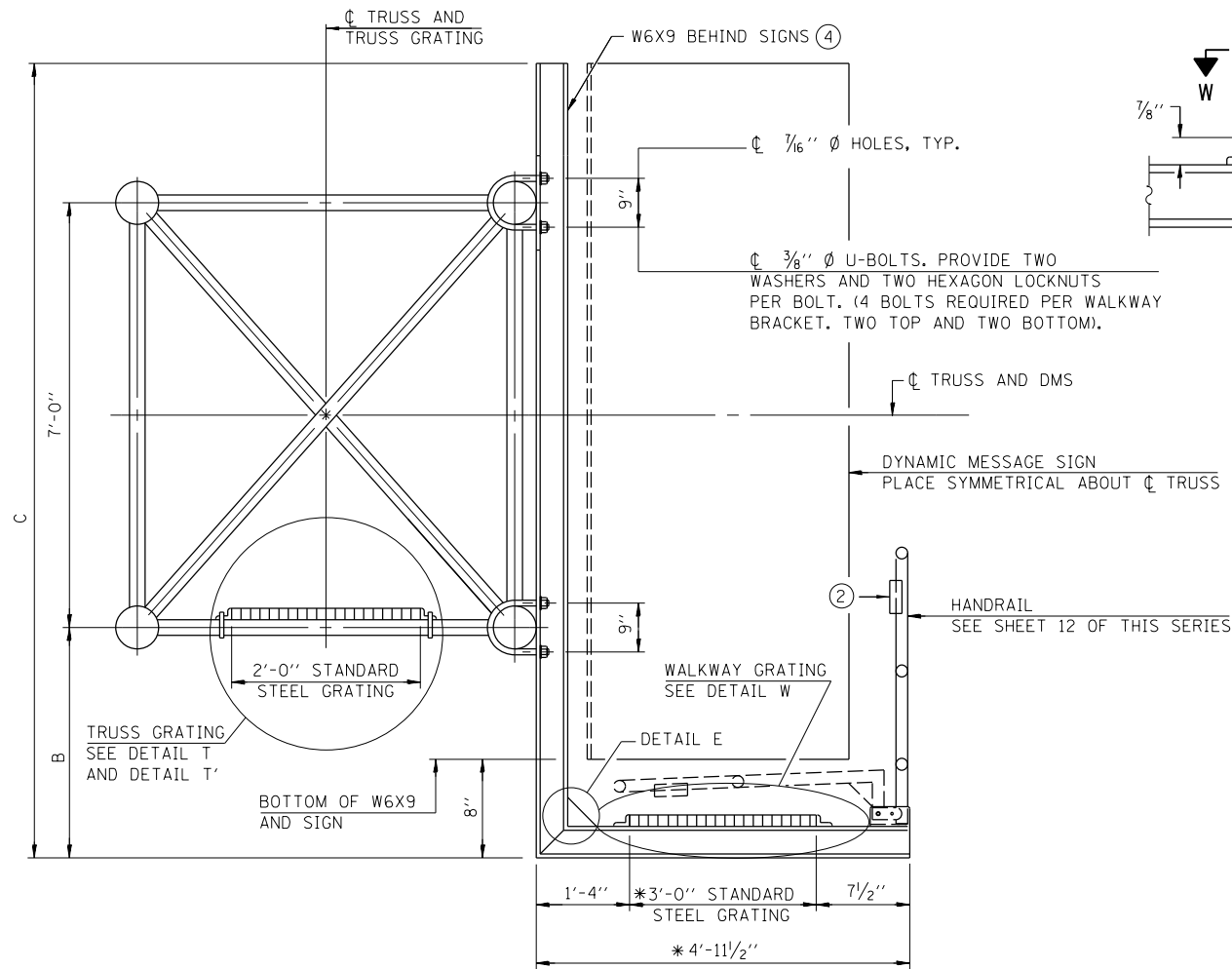

SECTION G-G

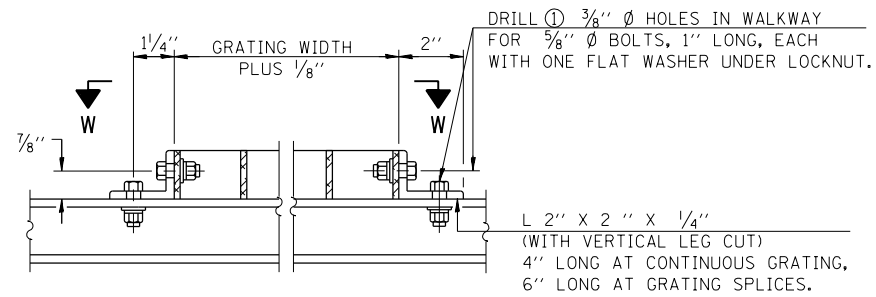

DETAIL W
(WALKWAY GRATING)

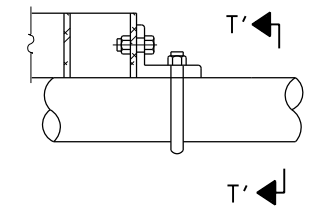

DETAIL T'

(TRUSS GRATING SPLICE)
DETAILS NOT SHOWN SAME AS DETAIL T.
ALTERNATE MATERIALS MAY BE USED
SUBJECT TO THE ENGINEER'S REVIEW
AND APPROVAL.

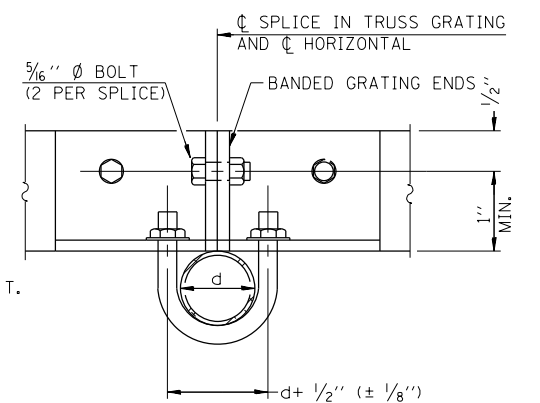

SECTION T'-T'

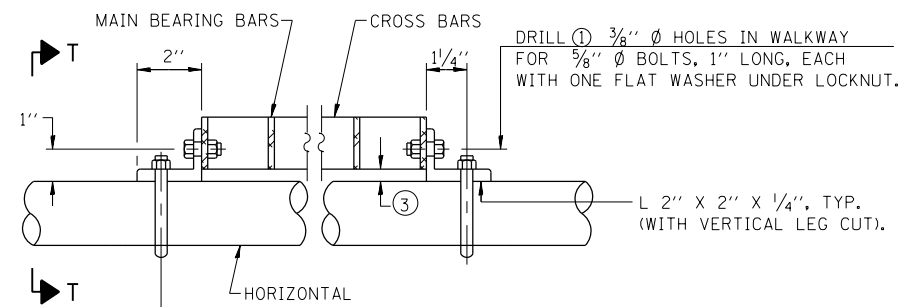

DETAIL T
(CONTINUOUS TRUSS GRATING)

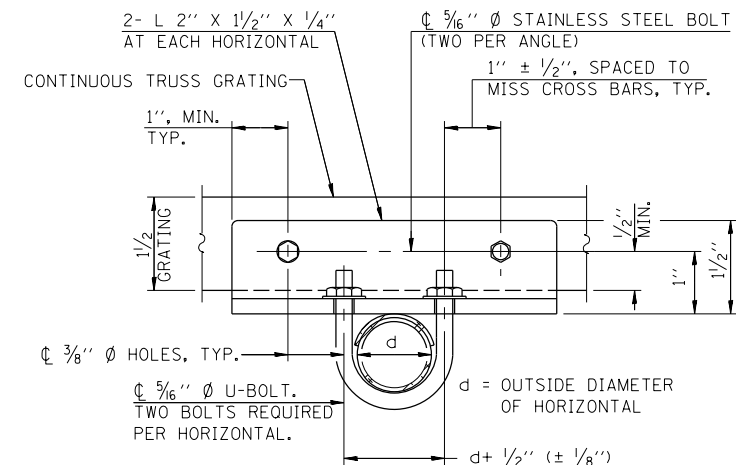

SECTION T-T

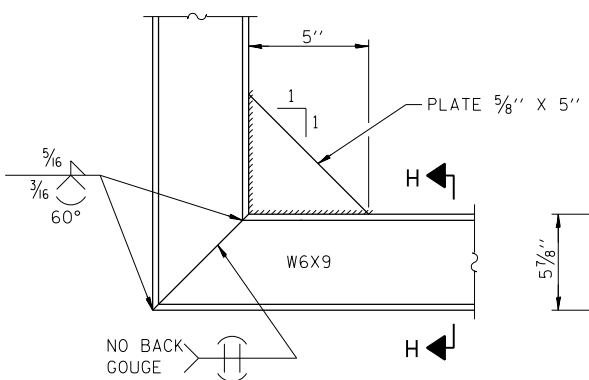

DETAIL E

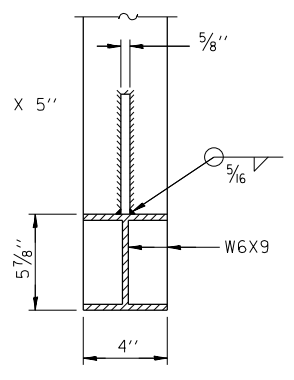

SECTION H-H

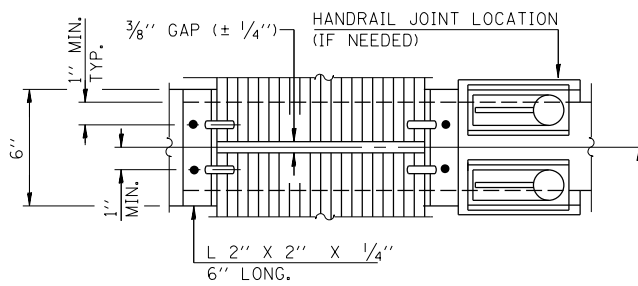

SECTION W-W
(CONTINUOUS WALKWAY GRATING)

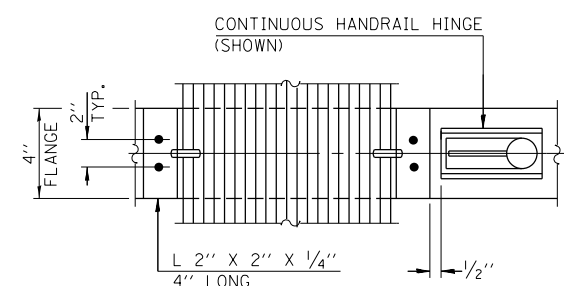

SECTION W-W
(CONTINUOUS WALKWAY GRATING)

NOTES:

- ① DRILLING HOLES IN GRATING MAY BE DONE IN SHOP OR FIELD, BASED ON CONTRACTOR'S PREFERENCE AND SUBJECT TO ACCURATE ALIGNMENT.
- ② PL 1/8" X 1/2" X 2" WELDED TO HANDRAIL POSTS TO PROTECT LOCATIONS THAT CONTACT GRATING.
- ③ TUBE TO GRATING GAP MAY VARY FROM 0 TO 1/2", MAX. TO ALIGN WALKWAY, ALLOW FOR CAMBER, ETC.
- ④ DMS MANUFACTURER MUST DESIGN AND SUPPLY HARDWARE FOR CONNECTION OF DMS TO W6x9. BOLTS MUST BE STAINLESS STEEL OR HOT DIP GALVANIZED HIGH STRENGTH PER ILLINOIS TOLLWAY SPECIFICATIONS.

* BRACKET AND GRATING DIMENSIONS ARE NOMINAL AND WILL VARY BASED ON ACTUAL DMS DIMENSIONS PLUS MANUFACTURER'S MOUNTING DEVICES.

BARS SIZES FOR STANDARD STEEL GRATING

TRUSS GRATING:	MAIN BEARING BARS 3/16" X 1 1/2" ON 1 3/16" CENTERS.
	CROSS BARS 3/16" X 1 1/2" ON 4" CENTERS.
WALKWAY GRATING:	MAIN BEARING BARS 3/16" X 1 1/2" ON 1 3/16" CENTERS.
	CROSS BARS 3/16" X 1 1/2" ON 4" CENTERS.

APPROVED: *Paul Kovacs* CHIEF ENGINEER DATE 5-20-2014



OVERHEAD SIGN STRUCTURE
SPAN TYPE (STEEL)
STRUCTURE DETAILS

STANDARD F17-01

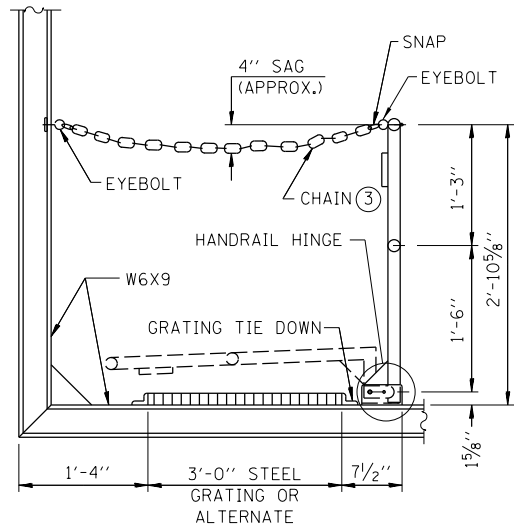

SIDE ELEVATION
(SHOWING SAFETY CHAIN W/O SIGN)

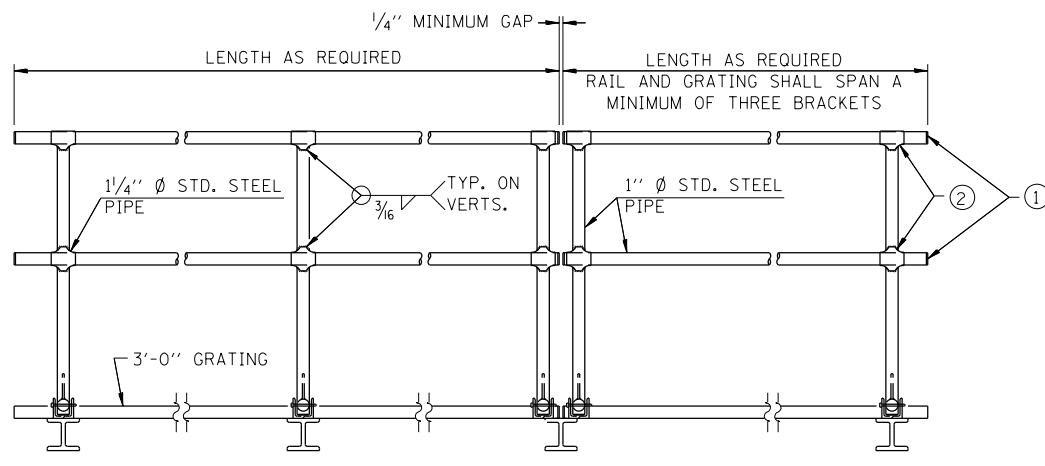

FRONT ELEVATION

HANDRAIL DETAILS

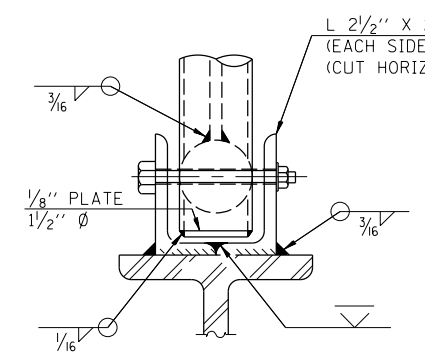

FRONT ELEVATION
SEE "ELEVATION" AT RIGHT FOR DIMENSIONS.

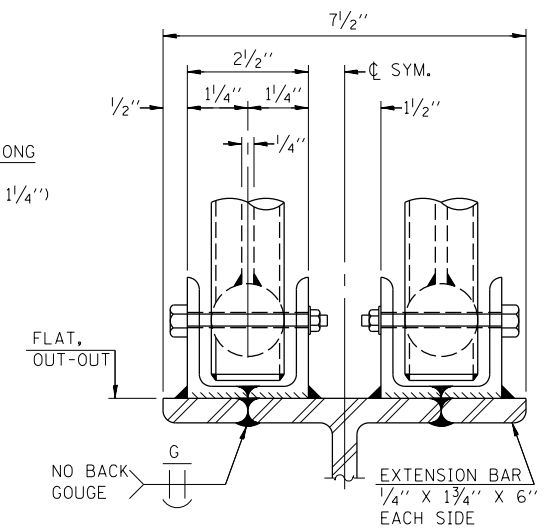

ELEVATION AT HANDRAIL JOINT

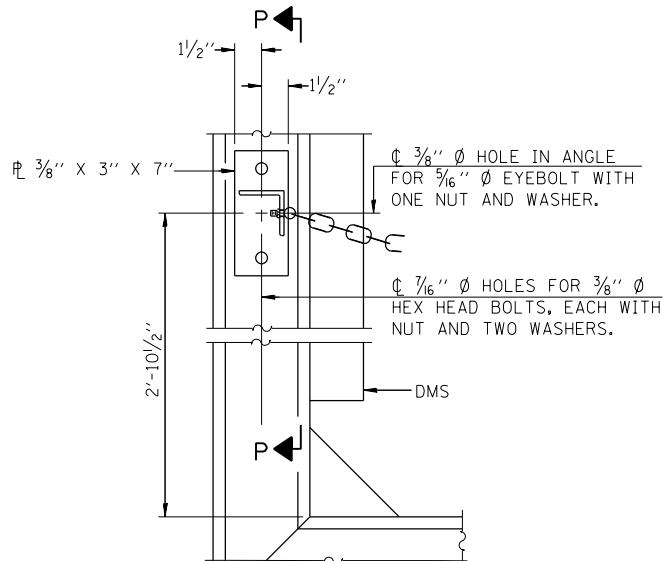

ALTERNATE SAFETY CHAIN ATTACHMENT
(WITH SIGN PRESENT)
ITEMS NOT SHOWN SAME AS "SIDE ELEVATION" OF "HANDRAIL DETAILS"

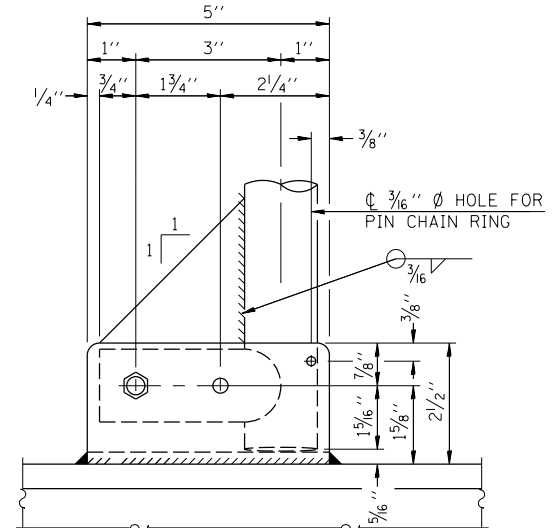

SIDE ELEVATION

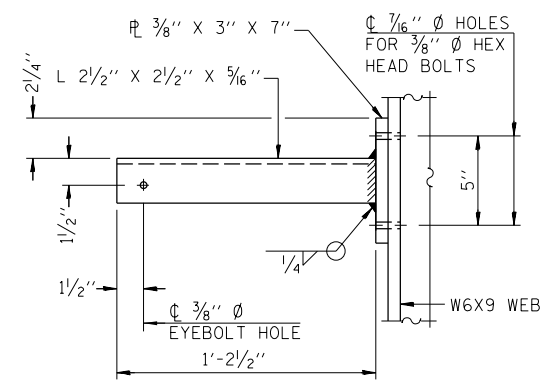

SECTION P-P

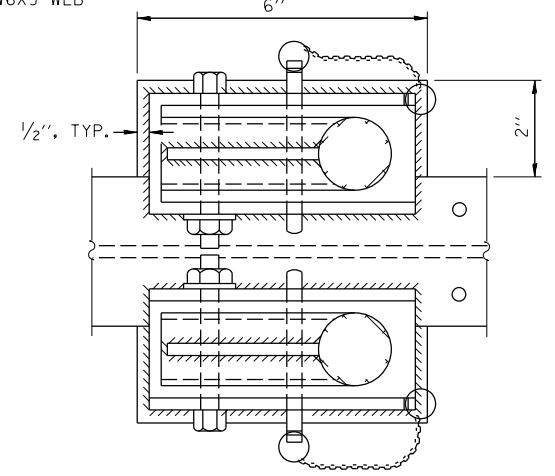

PLAN AT HANDRAIL JOINT
DETAILS NOT SHOWN SAME AS "PLAN"

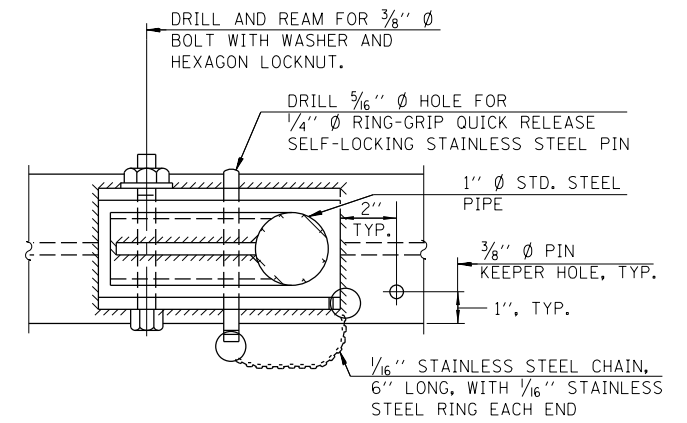

PLAN AT HANDRAIL HINGE

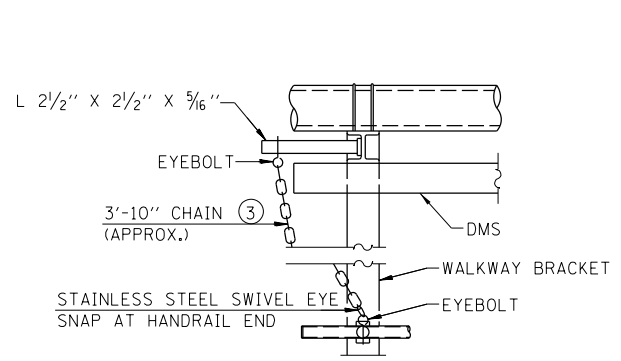

ALTERNATE SAFETY CHAIN ATTACHMENT
DETAILS NOT SHOWN SIMILAR TO "SAFETY CHAIN" DETAILS
(WALKWAY OMITTED FOR CLARITY)

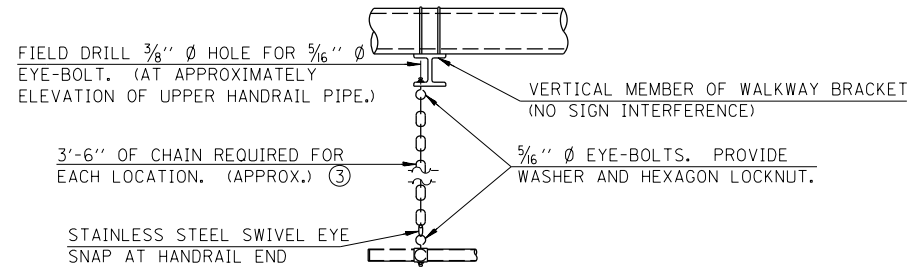

SAFETY CHAIN
ONE REQUIRED FOR EACH END OF EACH WALKWAY.

NOTES:

- INSTALL STANDARD FORCE-FIT END CAPS OR WELD 1/8" END PLATES WITH 1/8" C.F.W. AND GRIND SMOOTH. (ALL RAIL ENDS)
- HORIZONTAL HANDRAIL MEMBER SHALL BE CONTINUOUS THRU 1 1/4" DIAMETER PIPE. PROVIDE 7/16" DIAMETER HOLE IN 1 1/4" DIAMETER PIPE FOR 3/8" DIAMETER BOLT. FIELD DRILL 7/16" DIAMETER HOLE IN HORIZONTAL RAIL MEMBER. PROVIDE WASHER AND LOCKNUT FOR BOLT. (USE 3/16" EYEBOLTS IN 7/16" DIAMETER HOLES ON TOP RAIL AT ENDS ONLY.)
- 3/16" TYPE 304L STAINLESS STEEL CHAIN, APPROXIMATELY 12 LINKS PER FOOT.

