

Illinois Tollway Base Sheet Revisions

Section M	Base Sheet Drawings	
	Drawing	Modification Summary Effective: 03-01-2024
	Pole Assembly (ITS)-Series 1000	
	M-ITS-1000	Elevation Views Pole Mounted ITS Element Assembly
	Sheet 1	Added details for grounding busbar with dimensions
		In pole assembly top view: added identification of 1-1/2" CNC conduit
		In enclosure side view" changed to one 1 1/2" stainless steel power conduit
		In pole mounted assembly details: change CCTV-2 to CCTV-1
		Replace word "round" by word "ground"
		Removed notation to 8 strand
		Added detail for locate/tracer wire connected to ground busbar
		Removed reference to Note 1 in CCTV camera monotube mounting detail
	Sheet 2	Changed designation of Detail A by Detail B
		In side view of ITS Disconnect switch cast in place: changed reference to Detail A by reference to Detail B
	M-ITS-1001	General Notes Pole Mounted ITS Element Assembly
		Added Note 24: The door for ITS enclosure shall be installed vertically and on the left side of the cabinet when facing the cabinet
		Added Note to Designer: if a CCTV needs to be replaced and the distance to the Cisco switch in the Plaza communication room is greater than 300 feet but less than 500 feet, use Extended Range Ethernet Cat 6 cable. If the distance is greater than 500 feet then install a Video Power Junction Box Model B NEMA 4 near the trust structure or monotube and connect fiber link to the communication switch in communication room.
	M-ITS-1002	ITS Standard Foundation
		Changed the name for Helix Foundation Mounting Plate
	M-ITS-1003	ITS Concrete Service Pad
	Sheet 1	Changed the orientation of the traffic arrow rotated 180 degrees
		In plan view for concrete service pad: show Section B-B arrows upward
		Delete dimension 1'-8" concrete service pad detail plan view
		Delete dimension 1.2192 in Section B-B (Type A)
	Sheet 2	Section B-B (Type A) and Section B-B (Type B): service pad 1" above grade
		Align Section B-B with Plan view on top
		In plan view for concrete service pad type C: moved arrow for Section B-B upward
		Concrete service pad Type C: service pad 1" above grade
	M-ITS-1004	Spacer - Duct Package in a Trench
		New details of duct spacer for duct bank in a trench showing the conduit arrangement for fiber and power

New Sheet

Retired Standard

	SITE				SUPPORT TYPE		
	MILEPOST	STATION	OFFSET	ORIENTATION	POLE	FOUNDATION	MOUNTING HEIGHT
CCTV-1							
CCTV-2							
MVDS-1							
MVDS-2							
MVDS-3							
WIRELESS MODEM							
DC POWER (QTY OF SOLAR PANEL ON POLE)							
SOLAR GENERATOR							

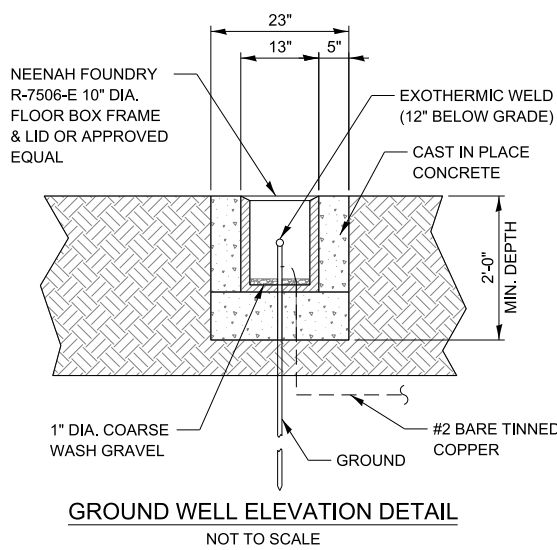
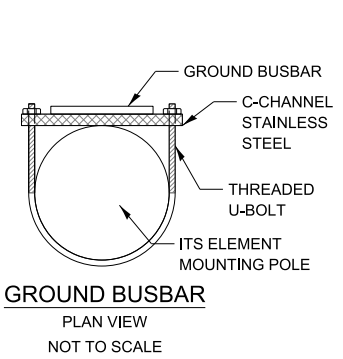
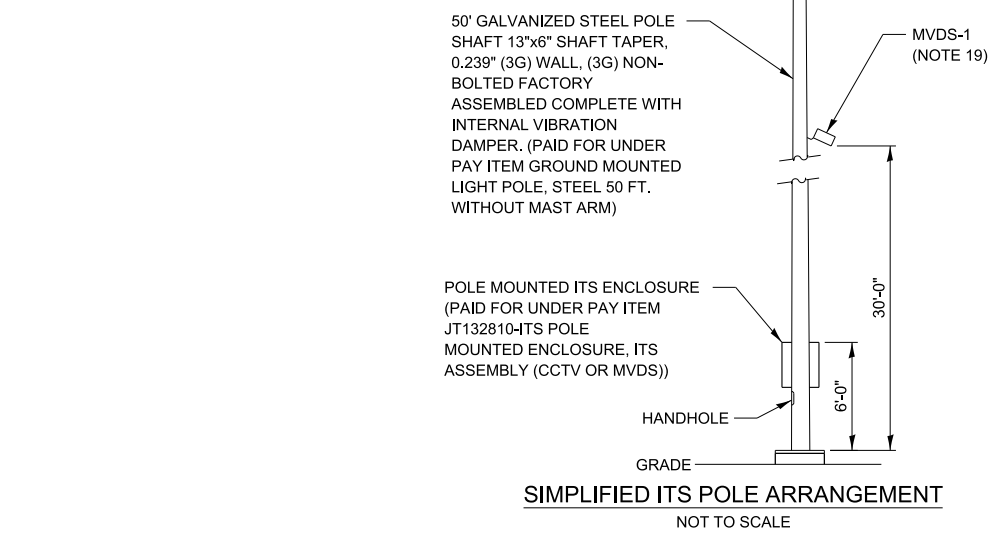
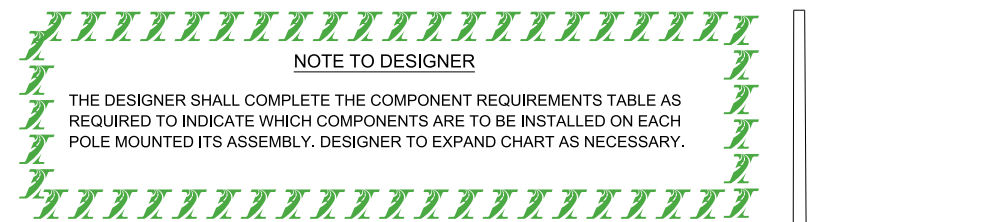

NOTE:
1. SEE M-ITS-1001 FOR NOTES.

NOTE TO DESIGNER
THIS BASE SHEET SHOWS TYPICAL CONSTRUCTION BUT IT IS NOT A STANDARD DRAWING. IT REQUIRES COMPLETION BY THE DESIGNER PRIOR TO INSERTION INTO A CONTRACT. MICROSTATION FILES AND THE "CADD STANDARDS MANUAL" ARE AVAILABLE ON THE ILLINOIS TOLLWAY WEBSITE. THE DESIGNER SHALL ACCEPT THE RESPONSIBILITY OF THE DESIGN OF THIS SHEET UPON ITS COMPLETION AND INSERTION INTO A CONTRACT. ALL "NOTE TO DESIGNER" BOXES SHALL BE REMOVED BY THE DESIGNER PRIOR TO INSERTION OF THE SHEET INTO THE PLAN SET.

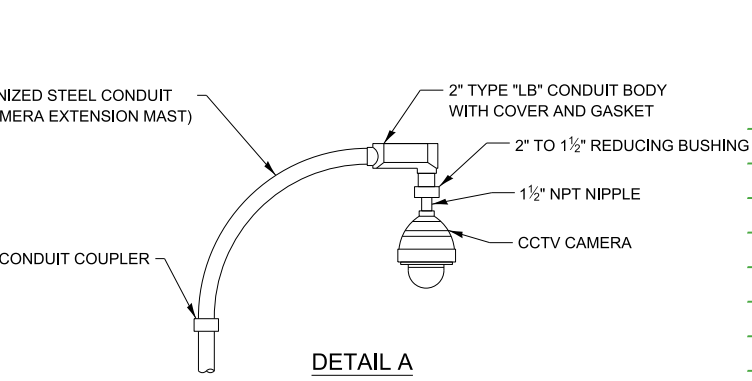
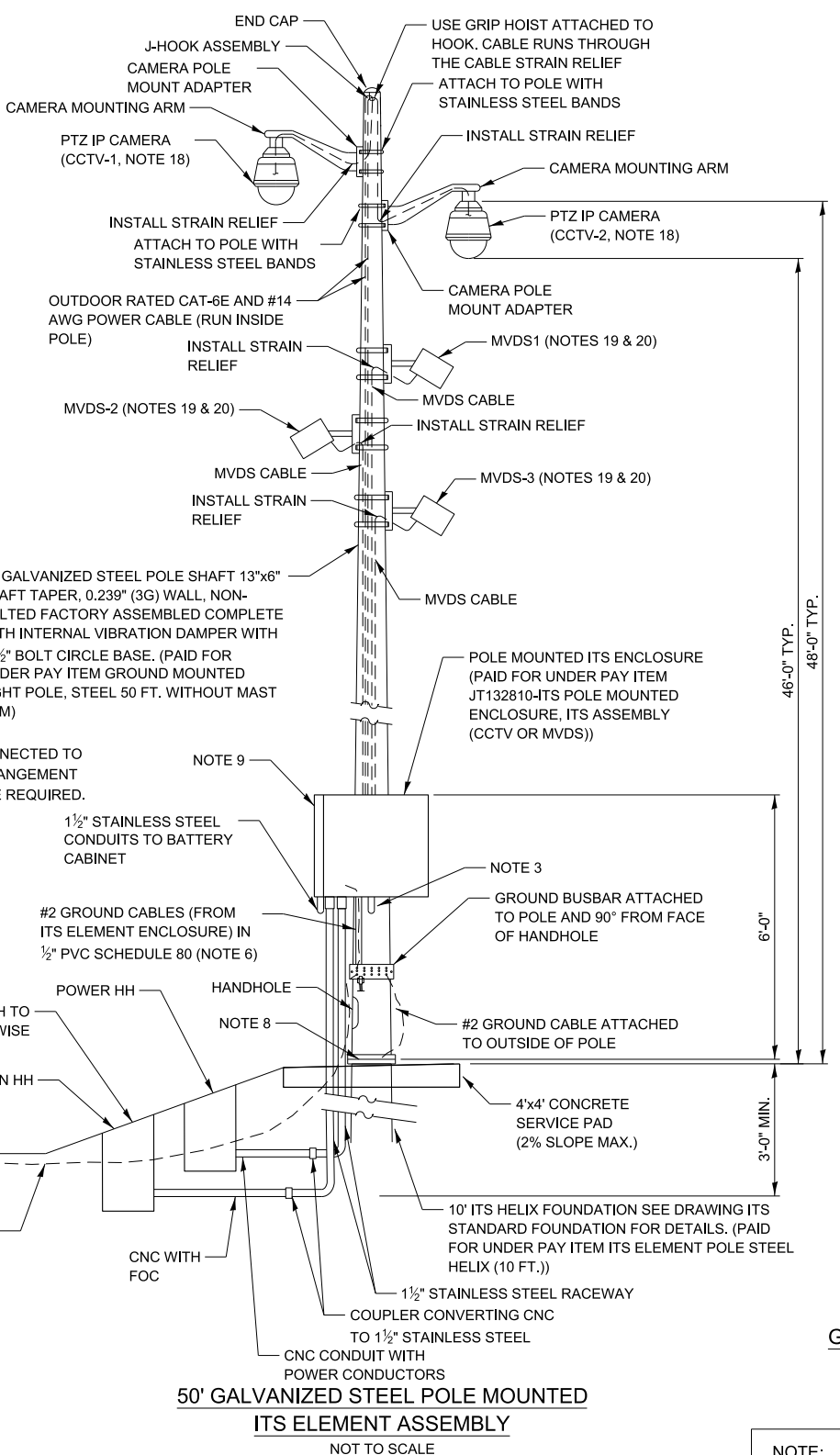
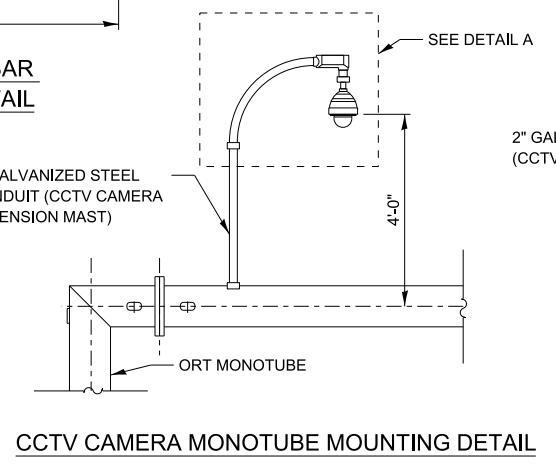
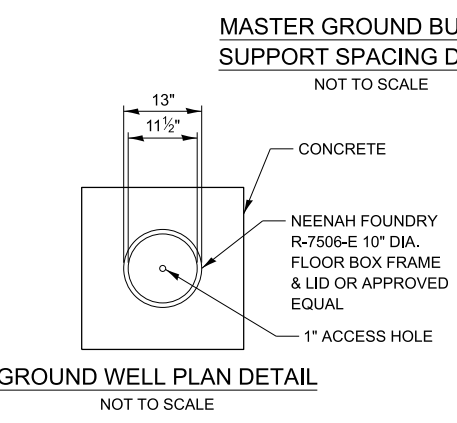
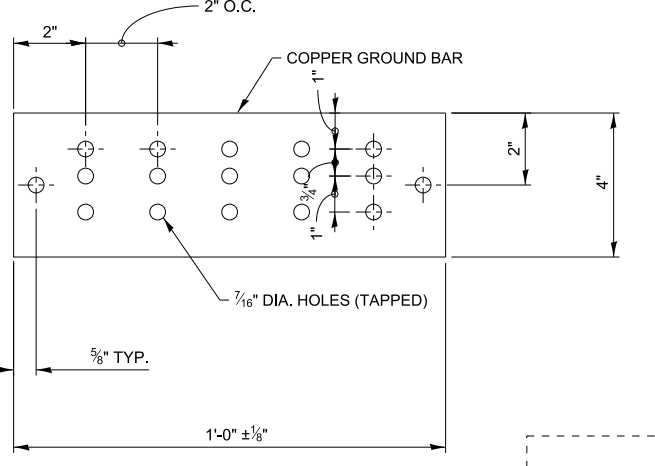
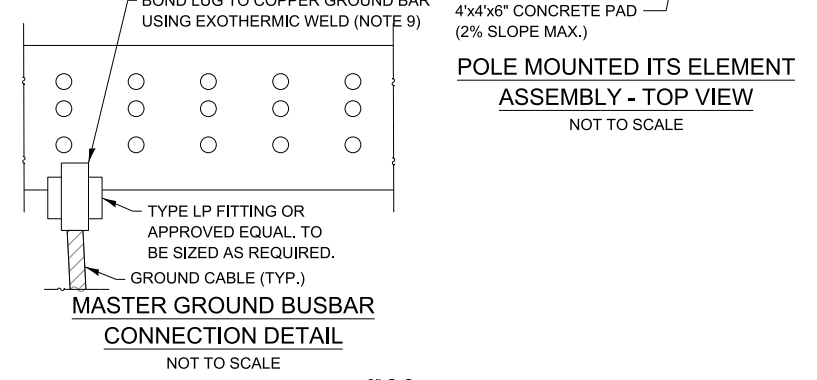
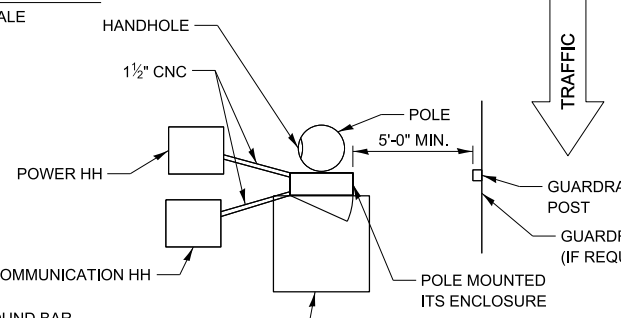
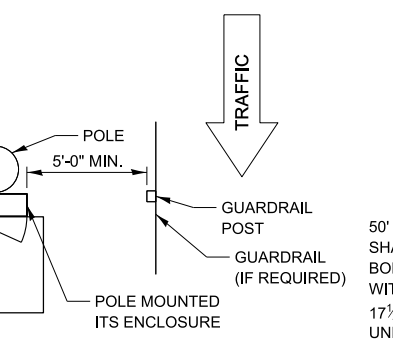
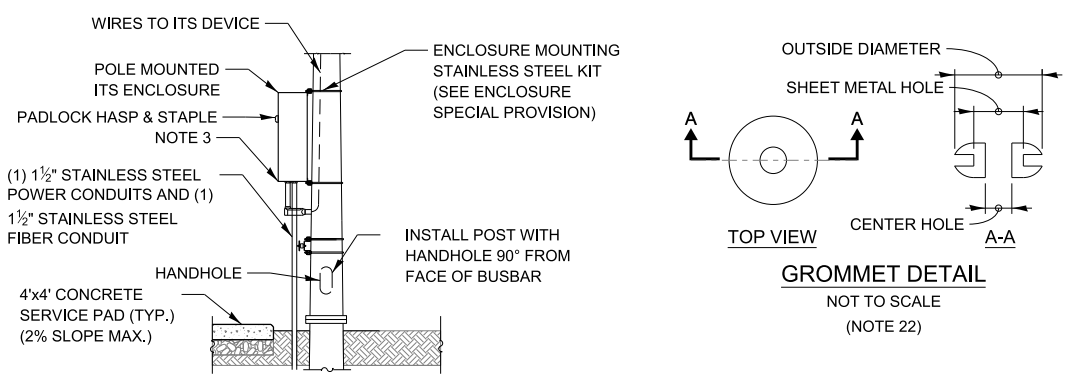

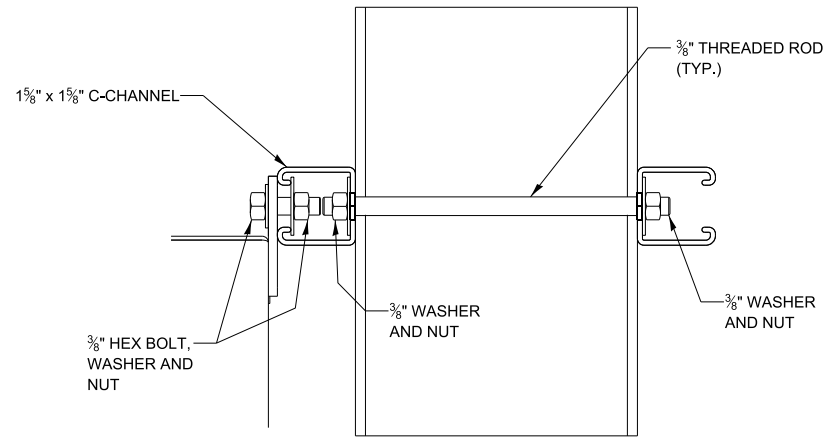

DETAIL A - TYPICAL MOUNTING ATTACHMENT CONNECTION

NOTES:

1. ALL CONCRETE SHALL BE IDOT CLASS SI.
2. DISCONNECT SWITCH, POSTS, FOUNDATION, AND MOUNTING HARDWARE ARE INCLUDED IN PAY ITEM "ITS DISCONNECT SWITCH ASSEMBLY" (JT132814).
3. DETAILS SHOWN IN THIS DRAWING APPLY ONLY TO LOCATIONS WHERE A STANDALONE DISCONNECT SWITCH IS REQUIRED AT AN ITS POLE.
4. THIS PRECAST ITS DISCONNECT SWITCH IS THE PREFERRED OPTION FOR WINTER INSTALLATION.

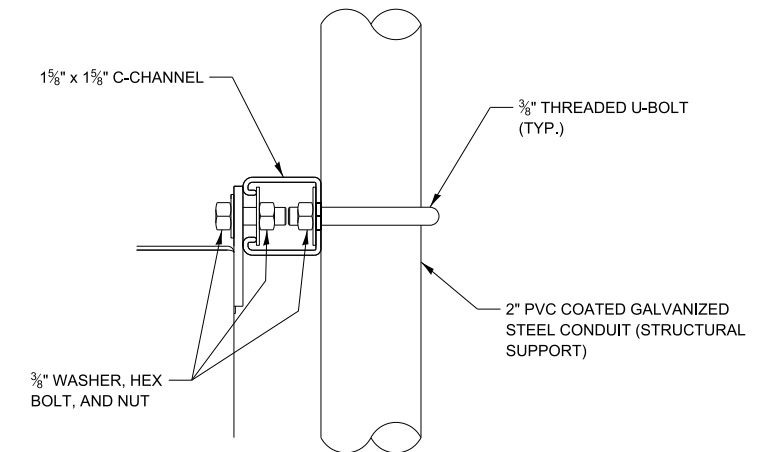

DETAIL B - TYPICAL MOUNTING ATTACHMENT CONNECTION

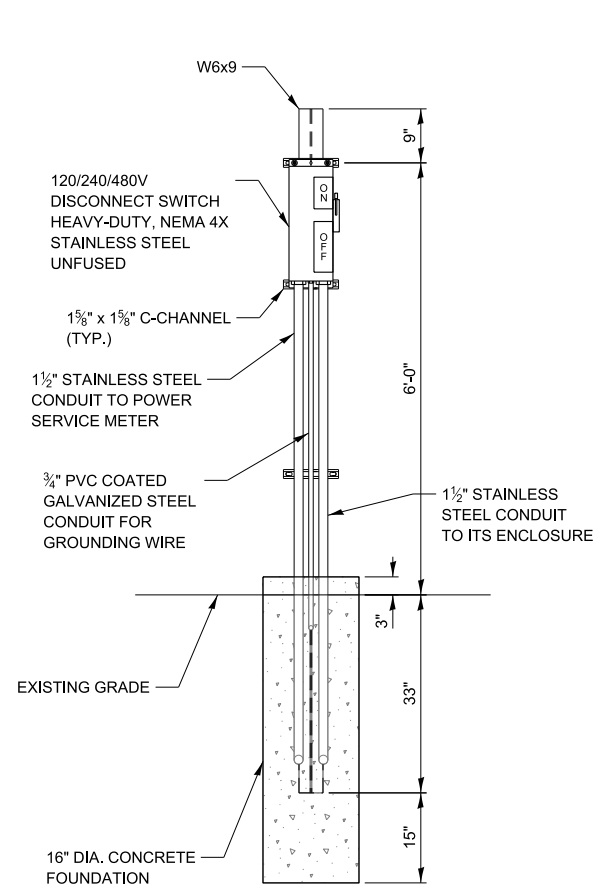

ITS DISCONNECT SWITCH PRECAST ASSEMBLY FRONT VIEW

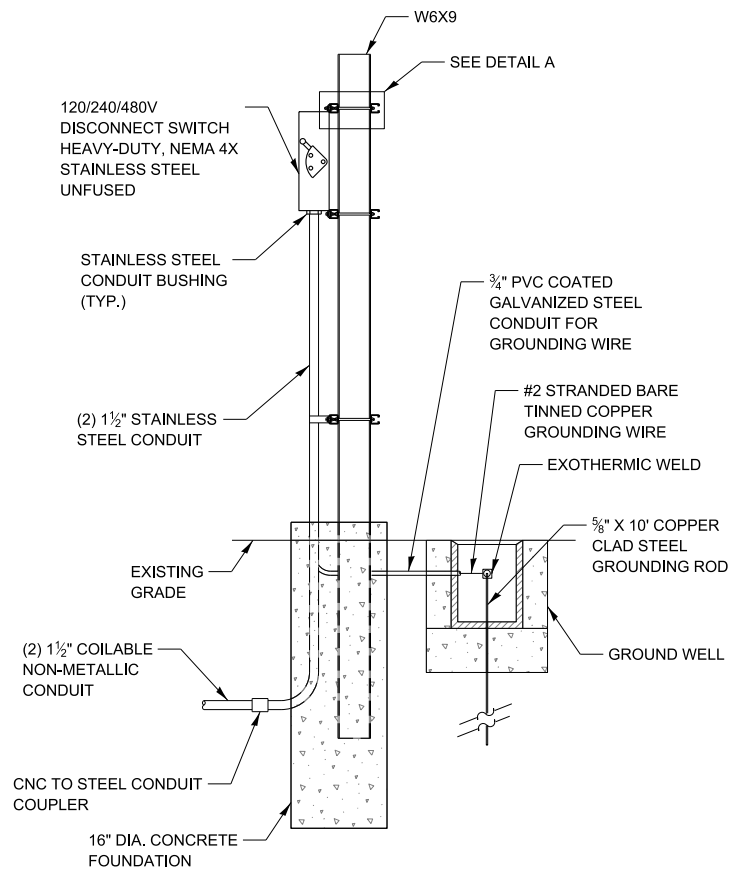

ITS DISCONNECT SWITCH PRECAST ASSEMBLY SIDE VIEW

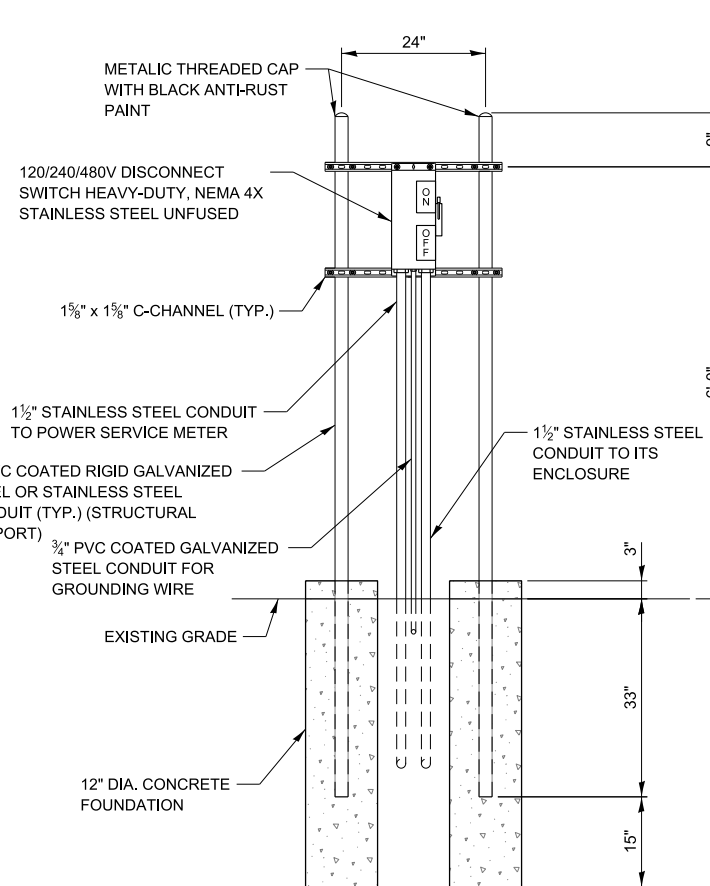

ITS DISCONNECT SWITCH CAST-IN-PLACE ASSEMBLY FRONT VIEW

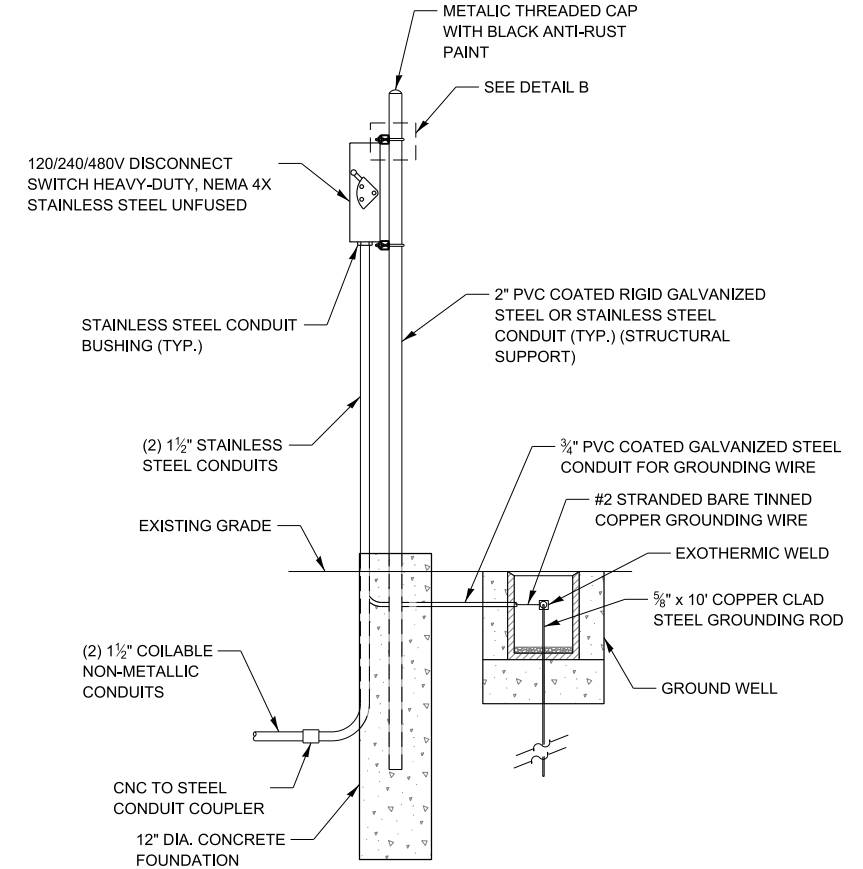

ITS DISCONNECT SWITCH CAST-IN-PLACE ASSEMBLY SIDE VIEW

NOTE TO DESIGNER

THIS BASE SHEET SHOWS TYPICAL CONSTRUCTION BUT IT IS NOT A STANDARD DRAWING. IT REQUIRES COMPLETION BY THE DESIGNER PRIOR TO INSERTION INTO A CONTRACT. MICROSTATION FILES AND THE "CADD STANDARDS MANUAL" ARE AVAILABLE ON THE ILLINOIS TOLLWAY WEBSITE. THE DESIGNER SHALL ACCEPT THE RESPONSIBILITY OF THE DESIGN OF THIS SHEET UPON ITS COMPLETION AND INSERTION INTO A CONTRACT. ALL "NOTE TO DESIGNER" BOXES SHALL BE REMOVED BY THE DESIGNER PRIOR TO INSERTION OF THE SHEET INTO THE PLAN SET.

GENERAL NOTES:

1. ITS ELEMENT POLES SHIELDED BY GUARDRAIL SHALL BE LOCATED A MINIMUM OF 5' TO A MAXIMUM OF 20' BEHIND THE GUARDRAIL POST. SEE ILLINOIS TOLLWAY GUARDRAIL STANDARD (SECTION C OF STANDARDS) FOR MORE INFORMATION. ALL OTHER POLES SHALL BE LOCATED OUTSIDE THE CLEAR ZONE. FINAL LOCATION TO BE APPROVED BY THE ENGINEER.
2. ANY GROUND CABLES ROUTED INSIDE THE ENCLOSURE SHALL BE GREEN INSULATED TYPE RHW CONDUCTORS. ANY GROUND CONDUCTORS THAT ARE BURIED SHALL BE BARE COPPER TINNED. ANY GROUND CONNECTED TO THE EXTERNAL GROUND BUSBAR SHALL BE CADWELDED TO THE BUSBAR. PVC SCH 80 CONDUIT SHOULD BE GROMMETTED ON END GOING TO BUSBAR TO PREVENT RODENTS AND INSECTS FROM ENTERING.
3. PROVIDE A 1½" ALUMINUM CONDUIT NIPPLE WITH LB FITTING FOR ROUTING ITS ELEMENT CABLES INSIDE THE POLE TO THE EQUIPMENT ENCLOSURE. DRILL AND TAP POLE FOR THE CONDUIT NIPPLE. CABLE SLACK SHALL BE PULLED AND FASTENED WITHIN THE TOP OF THE POLE. PROPER CABLE STRAIN RELIEF SHALL BE INSTALLED AND APPROVED BY THE ENGINEER. ALL CABLE RUN INSIDE THE POLE SHALL NOT HANG BELOW THE TOP OF THE HANDHOLE COVER ON THE POLE.
4. ALL CONDUITS ENTERING THE ENCLOSURE SHALL BE SEALED. SEE "ITS POLE MOUNTED ENCLOSURE, ITS ASSEMBLY (CCTV OR MVDS)" SPECIAL PROVISION FOR MORE DETAIL FOR RODENT PROTECTION.
5. CONTRACTOR TO PROVIDE ALL POWER, COMMUNICATIONS AND GROUND WIRING REQUIRED FOR SYSTEM OPERATION.
6. ATTACH PVC SCH 80 CONDUIT TO POLE FOR SUPPORT. USE METAL BUSHING WHEN CONNECTING PVC TO CABINET. USE GROMMETS AT BOTH ENDS OF CONDUIT TO SEAL CONDUIT BUT ALLOW GROUND CABLE TO RUN THROUGH BOTH ENDS.
7. GROUND ROD SHALL BE PLACED A MINIMUM OF 10' FROM THE FOUNDATION. A GROUND WELL SHALL BE INCLUDED TO PERMIT ACCESS TO THE GROUND ROD CONNECTION. CONNECTION TO THE GROUND BUSBAR AND THE GROUND ROD SHALL BE CADWELD.
8. A FLAT STEEL MESH PANEL ALONG WITH A COMMERCIALY AVAILABLE HYDROPHOBIC LOW DENSITY COMPOSITE BACKFILL MATERIAL (KNOWN AS Q-SET 250) SHALL BE INSTALLED BETWEEN THE ANCHOR BASE AND THE POLE TO PREVENT THE ENTRY OF RODENTS INTO THE POLE. SEE SPECIAL PROVISIONS FOR MORE DETAILS.
9. THIS ITS ELEMENT ENCLOSURE DETAIL WILL BE UTILIZED FOR POLE MOUNTED APPLICATIONS ONLY, IT CANNOT BE UTILIZED FOR TOWER MOUNTED APPLICATION.
10. BACKFILL PER ILLINOIS TOLLWAY STANDARD H1. BACKFILL SHALL BE TO THE TOP OF THE POLE BASE ON ALL SIDES.
11. ALL CABLING (INCLUDING CABLING INSIDE THE ENCLOSURE) IS OUTDOOR RATED. CAMERA CABLE PART NUMBERS ARE: CAT-6E CABLE (BELDEN CATALOG NO. 7953A) AND #14 AWG 3/C CCTV POWER CABLE (BELDEN CATALOG NO. 9367). THE GROUND WIRE (WHITE) IN THE 3/C #14 AWG POWER CABLE SHALL BE TAPED GREEN. ANY OTHER ITS ELEMENT WILL USE SPECIFIC CABLE ASSOCIATED TO THAT ELEMENT.
12. THE J-HOOK SHALL BE WELDED IN PLACE TO THE SIDE OF THE POLE, NEAR THE TOP OF THE POLE. THE CONTRACTOR SHALL PROVIDE A CUSTOM FLAT TOP POLE CAP THAT WILL FIT THE POLE TOP WITH THE J-HOOK WELDED TO THE SIDE. THE POLE CAP SHALL BE SECURED TO THE POLE BY DRILLING AND INSERTING SET SCREWS.
13. THIS DRAWING IS A MULTI-PURPOSE DRAWING THAT INCLUDES TWO TYPES OF CONNECTIONS TO A SOLAR POWERED BATTERY ENCLOSURE. IF SOLAR POWER IS UTILIZED, THEN THE SPECIAL PROVISIONS WILL CALL OUT THE MATERIAL AND NECESSARY CONNECTIONS TO THE ITS ELEMENT ENCLOSURE.
14. CONSTRUCT A 4 FT. X 4 FT. CONCRETE SERVICE PAD 6-INCHES FROM THE POLE BASE ON THE SAME SIDE AS THE ITS ENCLOSURE, CENTERED WITH THE ITS ENCLOSURE.
15. THIRTY DAYS PRIOR TO INSTALLING ANY NEW CCTV CAMERA, MVDS, SWITCH, WIRELESS OR FIBER OPTIC, THE CONTRACTOR SHALL COORDINATE DEVICE CONFIGURATION WITH THE ENGINEER.
16. THE DISCONNECT SWITCH, SUPPORT, AND ASSOCIATED CONDUIT SHALL BE INSTALLED FOR ITS SITES WHERE THE UTILITY SERVICE INSTALLATION IS GREATER THAN 500 FEET FROM THE ITS SITE OR LOCATED ON THE OPPOSITE SIDE OF THE ROADWAY FROM THE ITS SITE.
17. ALL SLOPE RATIOS ARE EXPRESSED AS UNITS OF VERTICAL DISPLACEMENT TO UNITS OF HORIZONTAL DISPLACEMENT (V:H).
22. CABLES SHALL ENTER POLES THROUGH A GROMMET. GROMMET SIZE SHALL BE CHOSEN SO THAT THE CENTER HOLE FORMS A WATER TIGHT SEAL AROUND THE CABLES.
23. IF HANDHOLE IS INSTALLED NEAR THE BOTTOM OF A DITCH, THEN IT SHALL NOT BE INSTALLED BELOW THE FIFTY YEAR FLOOD ELEVATION.
24. THE DOOR FOR THE ITS ENCLOSURE SHALL HAVE ITS HINGE INSTALLED VERTICALLY AND ON THE LEFT SIDE OF THE CABINET WHEN FACING THE CABINET.

CCTV NOTES:

18. FINAL PLACEMENT HEIGHTS OF THE CCTV CAMERAS SHALL BE BASED ON SITE CONDITIONS, ILLINOIS TOLLWAY OPERATIONAL NEEDS, AND AS PER MANUFACTURER'S MOUNTING RECOMMENDATIONS. THE HEIGHT SHALL BE APPROVED BY THE ENGINEER ONLY AFTER REVIEW BY ILLINOIS TOLLWAY ITS OPERATIONS. FOR SITE WHERE 2 CCTV TO BE INSTALLED ON SAME ITS POLE: KEEP A MINIMUM 24 INCHES HEIGHT DIFFERENCE BETWEEN THE 2 CCTVS.

MVDS NOTES:

19. FINAL PLACEMENT HEIGHT OF THE MVDS SHALL BE BASED ON SITE CONDITIONS. REFER TO THE MVDS MANUFACTURER'S INSTALLATION GUIDE FOR RECOMMENDATIONS. THE HEIGHT SHALL BE APPROVED BY THE ENGINEER. THE MVDS SHALL BE PERPENDICULARLY ALIGNED TO THE ROADWAY IT IS INTENDING TO BE SENSING.
20. TWO MVDS UNITS ARE REQUIRED FOR THE FOLLOWING APPLICATIONS:
 A) GATHER DATA FROM A MAINLINE ROADWAY SENSOR APPLICATION THAT REQUIRES TWO SENSORS.
 B) ONE MVDS MAY BE UTILIZED FOR MAINLINE ROADWAY SENSING, WHILE THE SECOND IS UTILIZED FOR RAMP COUNTING OR RQD. THE CONTRACTOR SHALL ORIENT THE MVDS UNITS PERPENDICULAR TO THE ROADWAY BEING DETECTED.
21. BATTERY ENCLOSURE TO BE ATTACHED ON THE SIDE OF THE POLE UPSTREAM TO TRAFFIC.

NOTE TO DESIGNER

WHEN A CCTV NEEDS TO BE INSTALLED AT A DISTANCE GREATER THAN 300 FEET BUT LESS THAN 500 FEET FROM THE COMMUNICATION SWITCH IN THE PLAZA COMMUNICATION ROOM THEN THE CONTRACTOR CAN USE THE ILLINOIS TOLLWAY APPROVED EXTENDED RANGE ETHERNET CAT 6 CABLE. BETWEEN 300 FEET TO 500 FEET THIS CABLE WILL AVOID THE NEED TO INSTALL AN ITS VIDEO JUNCTION BOX NEXT TO THE CCTV. WHEN THE DISTANCE IS GREATER THAN 500 FEET THEN INSTALL A VIDEO JUNCTION BOX MODEL B NEMA 4X (WITH COMMUNICATION SWITCH) AND FIBER OPTIC CABLE FROM THE VIDEO POWER JUNCTION BOX TO THE PLAZA COMMUNICATION ROOM.

NOTE TO DESIGNER

THIS BASE SHEET SHOWS TYPICAL CONSTRUCTION BUT IT IS NOT A STANDARD DRAWING. IT REQUIRES COMPLETION BY THE DESIGNER PRIOR TO INSERTION INTO A CONTRACT. MICROSTATION FILES AND THE "CADD STANDARDS MANUAL" ARE AVAILABLE ON THE ILLINOIS TOLLWAY WEBSITE. THE DESIGNER SHALL ACCEPT THE RESPONSIBILITY OF THE DESIGN OF THIS SHEET UPON ITS COMPLETION AND INSERTION INTO A CONTRACT. ALL "NOTE TO DESIGNER" BOXES SHALL BE REMOVED BY THE DESIGNER PRIOR TO INSERTION OF THE SHEET INTO THE PLAN SET.



GENERAL NOTES POLE MOUNTED ITS ELEMENT ASSEMBLY

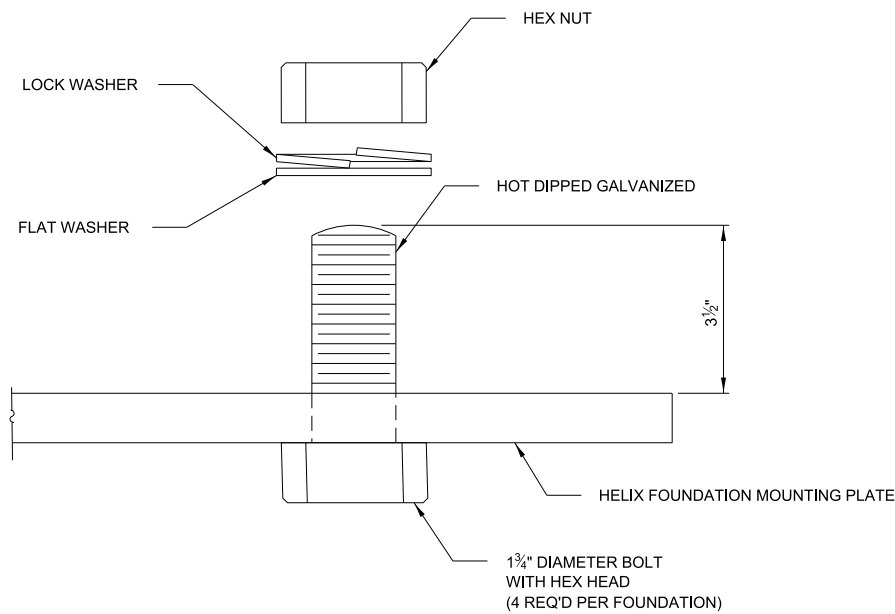

BASE ATTACHMENT DETAIL

17 1/2" BASE DIA.

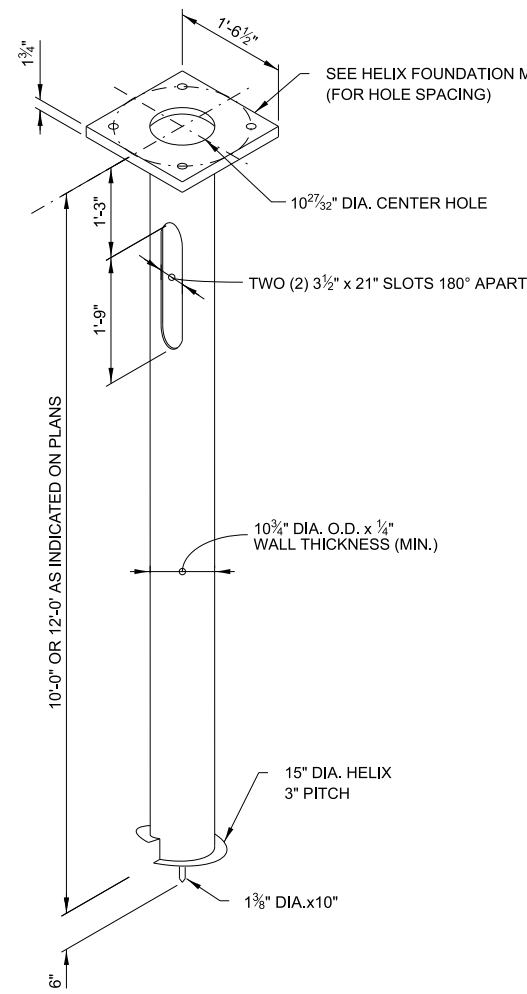

ISOMETRIC

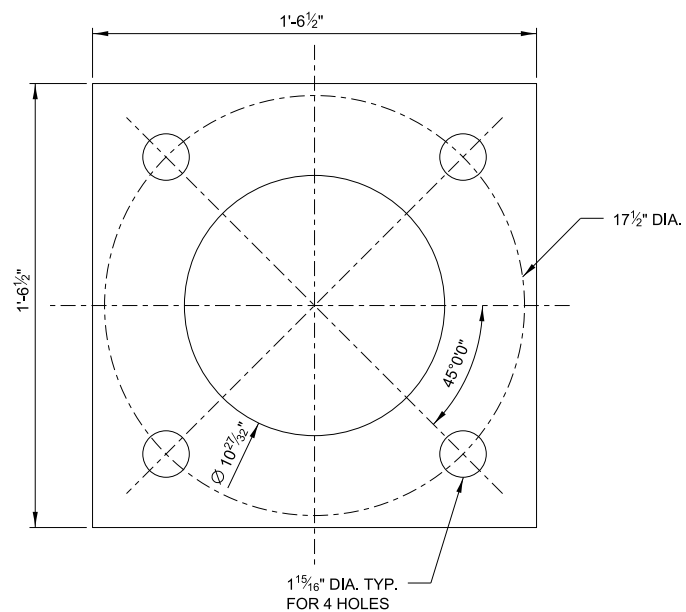

HELIX FOUNDATION MOUNTING PLATE

HELIX - GROUND MOUNTED ASSEMBLY

NOTE TO DESIGNER
 12 FT. STEEL HELIX FOUNDATIONS TO BE USED FOR SLOPES GREATER THAN 1:6. DESIGNER SHALL PROVIDE A TABLE TO BE INCLUDED ON THE PLANS WHICH INDICATES LOCATION, DEPTH OF FOUNDATION, AND ANY OTHER INFORMATION DEEMED NECESSARY FOR CONTRACTOR TO INSTALL PROPER FOUNDATION.

NOTE TO DESIGNER
 ALL NEW 50 FT. STEEL ITS POLES REQUIRE A 17 1/2" DIA. BOLT CIRCLE. SHOULD A 15" DIA. BOLT CIRCLE BE REQUIRED, THE DSE SHALL REFERENCE ILLINOIS TOLLWAY STANDARD DRAWING H1 (LIGHT STANDARD FOUNDATION).

NOTE TO DESIGNER
 THIS BASE SHEET SHOWS TYPICAL CONSTRUCTION BUT IT IS NOT A STANDARD DRAWING. IT REQUIRES COMPLETION BY THE DESIGNER PRIOR TO INSERTION INTO A CONTRACT. MICROSTATION FILES AND THE "CADD STANDARDS MANUAL" ARE AVAILABLE ON THE ILLINOIS TOLLWAY WEBSITE. THE DESIGNER SHALL ACCEPT THE RESPONSIBILITY OF THE DESIGN OF THIS SHEET UPON ITS COMPLETION AND INSERTION INTO A CONTRACT. ALL "NOTE TO DESIGNER" BOXES SHALL BE REMOVED BY THE DESIGNER PRIOR TO INSERTION OF THE SHEET INTO THE PLAN SET.



ITS STANDARD FOUNDATION

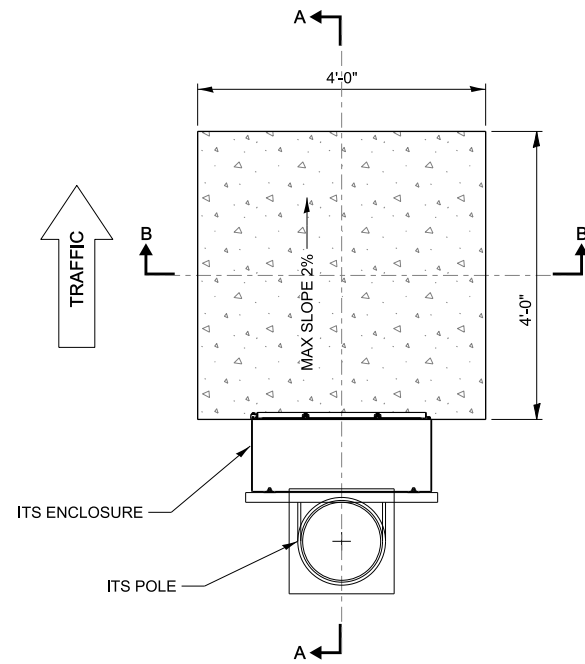

CONCRETE SERVICE PAD FOR ITS POLE

PLAN VIEW

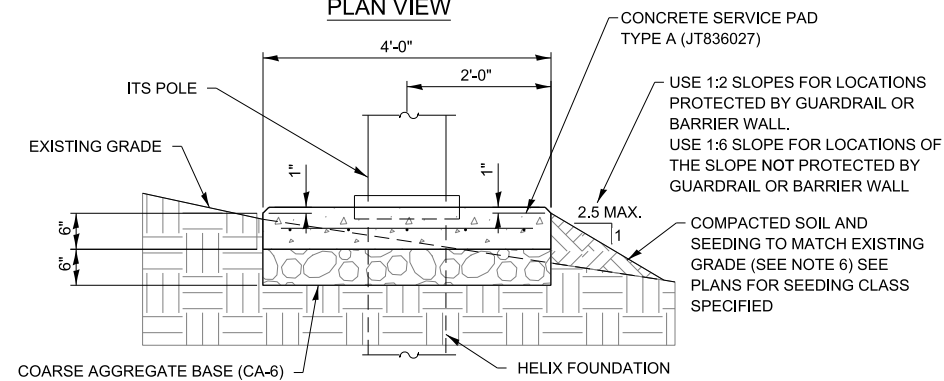

SECTION B-B (TYPE A)

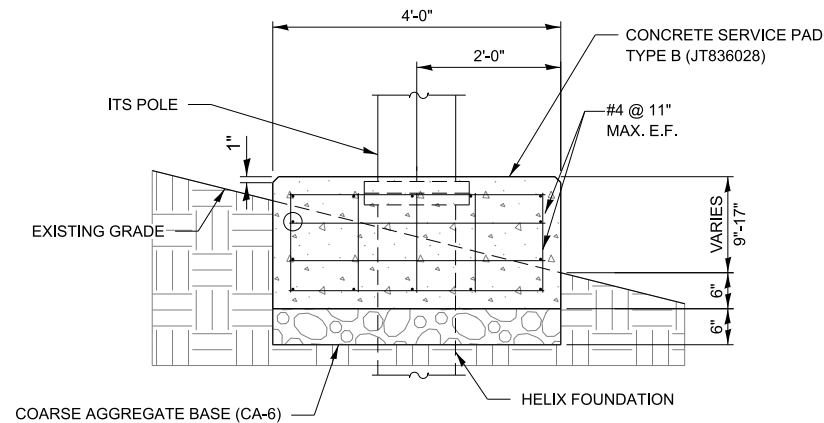

SECTION B-B (TYPE B)

DESIGN STRESSES

CONCRETE

CAST-IN-PLACE: $f_c = 3,500$ PSI AT 14 DAYS (CLASS SI)
 PRE-CAST: $f_c = 3,500$ PSI AT 5 DAYS, $f_c = 5,000$ PSI AT 28 DAYS (CLASS PC)

STEEL

ASTM A615, GRADE 60 DEFORMED: $F_y = 60,000$ PSI (EPOXY COATED)
 OR
 WELDED WIRE MESH: $F_y = 60,000$ PSI - 6x6 D10

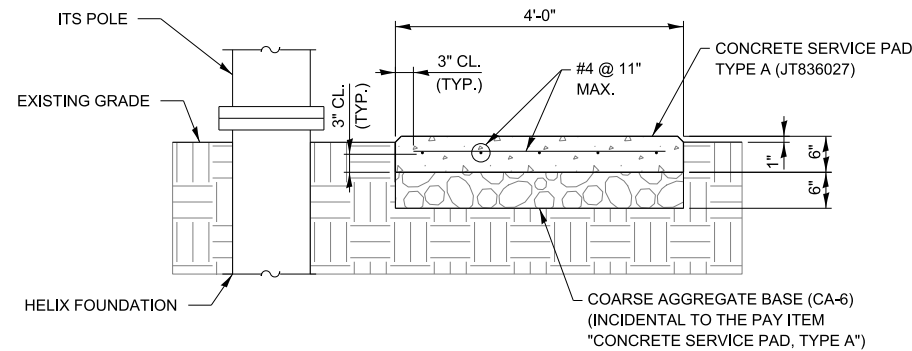

SECTION A-A (TYPE A)

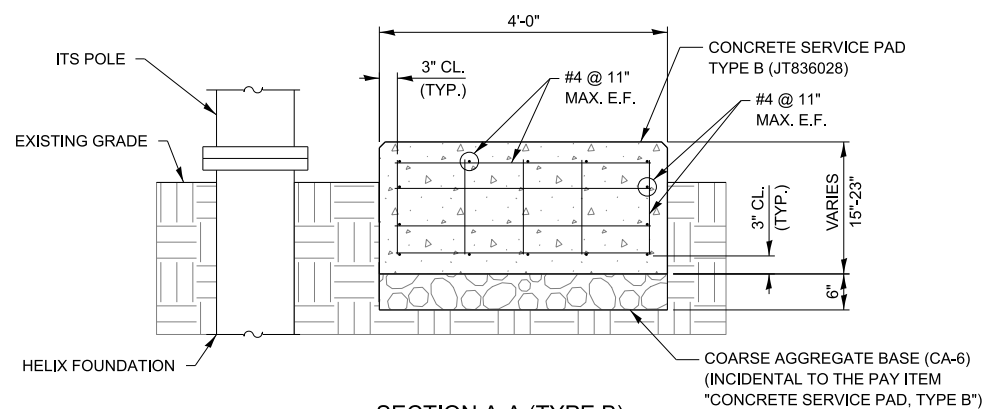

SECTION A-A (TYPE B)

NOTES:

- TYPE A SERVICE PADS SHALL BE INSTALLED ON SLOPES UP TO AND INCLUDING 1:6 (V:H).
- TYPE B SERVICE PADS SHALL BE INSTALLED ON SLOPES GREATER THAN 1:6 AND LESS THAN OR EQUAL TO 1:3.
- TYPE C SERVICE PADS SHALL BE INSTALLED ON SLOPES GREATER THAN 1:3 AS SHOWN ON SHEET M-ITS-1003 SHEET 2 OF 2.
- ALL EXPOSED CONCRETE EDGES SHALL HAVE A 1" MINIMUM CHAMFER.
- CONTRACTOR SHALL TAKE PRECAUTIONS TO STABILIZE EXISTING ITS POLES AND HELIX FOUNDATIONS WHILE EXCAVATING SOIL FOR INSTALLATION OF CONCRETE SERVICE PADS.
- COMPACTED SOIL SHALL BE PLACED TO BE LEVEL WITH THE SERVICE PAD. CONTRACTOR MAY USE EXCAVATED SOIL FROM PLACING THE PAD'S AGGREGATE BASE FOR GRADING PURPOSES WITH APPROVAL OF THE ENGINEER. SEEDING AND EROSION CONTROL SHALL BE PER THE GENERAL NOTES ON SHEET GN-08.
- SOIL EXCAVATED FOR THE PURPOSE OF MAINTAINING A STABLE WORKING SLOPE WHILE INSTALLING THE SERVICE PAD SHALL BE REPLACED. BACKFILL SHALL BE EARTH WHICH IS FREE FROM DEBRIS, CINDERS, AND ROCKS MEASURING 2" OR GREATER IN DIAMETER. IN THE EVENT THAT EXCAVATED MATERIAL IS UNSUITABLE FOR USE AS BACKFILL, THE CONTRACTOR SHALL USE A CLEAN, NATURAL SAND. THIS SUBSTITUTE BACKFILL SHALL BE INCIDENTAL TO THE SERVICE PAD INSTALLATION AND WILL NOT BE PAID FOR SEPARATELY. ALL BACKFILL MATERIALS SHALL BE COMPACTED TO THE SATISFACTION OF THE ENGINEER.
- THE TOP SURFACE OF SOIL DISTURBED BY EXCAVATION FOR PLACING THE SERVICE PADS SHALL BE SEEDED AND PROTECTED WITH EROSION CONTROL MEASURES PER THE GENERAL NOTES ON SHEET GN-08.
- SURFACE OF SERVICE PADS SHALL BE BROOM FINISHED.
- SERVICE PAD MAY BE PRECAST TO MATCH TYPE A (JT836027) OR TYPE B (JT836028) PAD ACCORDINGLY.
- ALL EMBEDDED LIFTING HARDWARE USED SHALL BE GALVANIZED.
- FOR LIFTING INSERT, INSTALLATION SHALL BE IN ACCORDANCE WITH THE MANUFACTURER'S SPECIFICATION INCLUDING MINIMUM EDGE DISTANCE AND SPACING REQUIREMENTS AND HAVE A 4:1 SAFETY FACTOR.
- FOR LIFTING PLATES, INSTALLATION SHALL BE IN ACCORDANCE WITH MANUFACTURER'S SPECIFICATIONS AND HAVE A STANDARD 5:1 SAFETY FACTOR FOR THE LIFTING HARDWARE.
- PRECAST SERVICE PADS SHALL BE TRANSPORTED IN SUCH A MANNER THAT THE PAD WILL NOT BE DAMAGED DURING TRANSPORTATION. PLASTIC CORNER PIECES OR SHOCK-ABSORBING CUSHIONING MATERIAL SHALL BE USED AT ALL BEARING POINTS AND ALL EXPOSED CORNERS DURING TRANSPORTATION OF THE PRECAST ELEMENTS. PADS SHALL BE PROPERLY SUPPORTED DURING TRANSPORTATION SUCH THAT CRACKING OR DEFORMATION DOES NOT OCCUR. IF MORE THAN ONE PAD IS TRANSPORTED PER VEHICLE, PROPER SUPPORT AND SEPARATION MUST BE PROVIDED BETWEEN INDIVIDUAL PADS. PADS MUST BE LYING HORIZONTALLY DURING TRANSPORTATION, UNLESS OTHERWISE APPROVED.
- PRECAST ELEMENT DAMAGED DURING HANDLING AND STORAGE SHALL BE REPAIRED OR REPLACED AT NO COST TO THE ILLINOIS TOLLWAY.
- A PRECAST PAD SHALL NOT BE TRANSPORTED FROM THE CASTING YARD UNTIL A MINIMUM 5 DAY COMPRESSIVE STRENGTH SPECIFIED HAS BEEN ATTAINED.
- MATERIAL QUALITY AND CONDITION AFTER SHIPMENT WILL BE INSPECTED AFTER DELIVERY TO THE CONSTRUCTION SITE, WITH THIS AND ANY PREVIOUS INSPECTIONS CONSTITUTING ON PARTIAL ACCEPTANCE.
- REPAIR OF DAMAGE CAUSE TO THE PADS DURING FABRICATION, LIFTING AND HANDLING, OR TRANSPORTATION SHALL BE ADDRESSED ON A CASE-BY-CASE BASIS. DAMAGE WITHIN ACCEPTABLE LIMITS CAUSED TO THE TOP OF THE SURFACES OR TO KEYED EDGES OF THE PADS SHALL BE REPAIRED USING AN APPROVED REPAIR METHOD AT THE FABRICATION PLANT AT THE EXPENSE OF THE CONTRACTOR. REPETITIVE DAMAGE TO THE PADS SHALL BE CAUSE FOR STOPPAGE OF FABRICATION OPERATION UNTIL CAUSE OF DAMAGE CAN BE REMEDIED.
- THE CONTRACTOR SHALL RETAIN THE SOLE RESPONSIBILITY FOR THE MEANS, METHODS, AND TECHNIQUES OF CONSTRUCTION OF THE PADS AND FOR COMPLIANCE WITH LAWS, REGULATIONS, AND CODES, AND FOR THE SAFETY OF CONSTRUCTION APPLICABLE TO THIS WORK.

NOTE TO DESIGNER

THIS BASE SHEET SHOWS TYPICAL CONSTRUCTION BUT IT IS NOT A STANDARD DRAWING. IT REQUIRES COMPLETION BY THE DESIGNER PRIOR TO INSERTION INTO A CONTRACT. MICROSTATION FILES AND THE "CADD STANDARDS MANUAL" ARE AVAILABLE ON THE ILLINOIS TOLLWAY WEBSITE. THE DESIGNER SHALL ACCEPT THE RESPONSIBILITY OF THE DESIGN OF THIS SHEET UPON ITS COMPLETION AND INSERTION INTO A CONTRACT. ALL "NOTE TO DESIGNER" BOXES SHALL BE REMOVED BY THE DESIGNER PRIOR TO INSERTION OF THE SHEET INTO THE PLAN SET.

CONCRETE SERVICE PAD DETAILS



ITS CONCRETE SERVICE PAD

NOTES:

- TYPE A SERVICE PADS SHALL BE INSTALLED ON SLOPES UP TO AND INCLUDING 1:6 (V:H).
- TYPE B SERVICE PADS SHALL BE INSTALLED ON SLOPES GREATER THAN 1:6 AND LESS THAN OR EQUAL TO 1:3 WHEN WELL BEYOND THE CLEAR ZONE.
- TYPE C SERVICE PADS SHALL BE INSTALLED ON SLOPES GREATER THAN 1:3 AS SHOWN ON SHEET M-ITS-1003 SHEET 2 OF 2.
- ALL EXPOSED CONCRETE EDGES SHALL HAVE A 1" MINIMUM CHAMFER.
- CONTRACTOR SHALL TAKE PRECAUTIONS TO STABILIZE EXISTING ITS POLES AND HELIX FOUNDATIONS WHILE EXCAVATING SOIL FOR INSTALLATION OF CONCRETE SERVICE PADS.
- COMPACTED SOIL SHALL BE PLACED TO BE LEVEL WITH THE SERVICE PAD. CONTRACTOR MAY USE EXCAVATED SOIL FROM PLACING THE PAD'S AGGREGATE BASE FOR GRADING PURPOSES WITH APPROVAL OF THE ENGINEER. SEEDING AND EROSION CONTROL SHALL BE PER THE GENERAL NOTES ON SHEET GN-08.
- SOIL EXCAVATED FOR THE PURPOSE OF MAINTAINING A STABLE WORKING SLOPE WHILE INSTALLING THE SERVICE PAD SHALL BE REPLACED. BACKFILL SHALL BE EARTH WHICH IS FREE FROM DEBRIS, CINDERS, AND ROCKS MEASURING 2" OR GREATER IN DIAMETER. IN THE EVENT THAT EXCAVATED MATERIAL IS UNSUITABLE FOR USE AS BACKFILL, THE CONTRACTOR SHALL USE A CLEAN, NATURAL SAND. THIS SUBSTITUTE BACKFILL SHALL BE INCIDENTAL TO THE SERVICE PAD INSTALLATION AND WILL NOT BE PAID FOR SEPARATELY. ALL BACKFILL MATERIALS SHALL BE COMPACTED TO THE SATISFACTION OF THE ENGINEER.
- THE TOP SURFACE OF SOIL DISTURBED BY EXCAVATION FOR PLACING THE SERVICE PADS SHALL BE SEEDED AND PROTECTED WITH EROSION CONTROL MEASURES PER THE GENERAL NOTES ON SHEET GN-08.
- SURFACE OF SERVICE PADS SHALL BE BROOM FINISHED.
- ALL EMBEDDED LIFTING HARDWARE USED SHALL BE GALVANIZED.
- FOR LIFTING INSERT, INSTALLATION SHALL BE IN ACCORDANCE WITH THE MANUFACTURER'S SPECIFICATION INCLUDING MINIMUM EDGE DISTANCE AND SPACING REQUIREMENTS AND HAVE A 4:1 SAFETY FACTOR.
- FOR LIFTING PLATES, INSTALLATION SHALL BE IN ACCORDANCE WITH MANUFACTURER'S SPECIFICATIONS AND HAVE A STANDARD 5:1 SAFETY FACTOR FOR THE LIFTING HARDWARE.
- PRECAST SERVICE PADS SHALL BE TRANSPORTED IN SUCH A MANNER THAT THE PAD WILL NOT BE DAMAGED DURING TRANSPORTATION. PLASTIC CORNER PIECES OR SHOCK-ABSORBING CUSHIONING MATERIAL SHALL BE USED AT ALL BEARING POINTS AND ALL EXPOSED CORNERS DURING TRANSPORTATION OF THE PRECAST ELEMENTS. PADS SHALL BE PROPERLY SUPPORTED DURING TRANSPORTATION SUCH THAT CRACKING OR DEFORMATION DOES NOT OCCUR. IF MORE THAN ONE PAD IS TRANSPORTED PER VEHICLE, PROPER SUPPORT AND SEPARATION MUST BE PROVIDED BETWEEN INDIVIDUAL PADS. PADS MUST BE LYING HORIZONTALLY DURING TRANSPORTATION, UNLESS OTHERWISE APPROVED.
- PRECAST ELEMENT DAMAGED DURING HANDLING AND STORAGE SHALL BE REPAIRED OR REPLACED AT NO COST TO THE ILLINOIS TOLLWAY.
- A PRECAST PAD SHALL NOT BE TRANSPORTED FROM THE CASTING YARD UNTIL A MINIMUM 5 DAY COMPRESSIVE STRENGTH SPECIFIED HAS BEEN ATTAINED.
- MATERIAL QUALITY AND CONDITION AFTER SHIPMENT WILL BE INSPECTED AFTER DELIVERY TO THE CONSTRUCTION SITE, WITH THIS AND ANY PREVIOUS INSPECTIONS CONSTITUTING ON PARTIAL ACCEPTANCE.
- REPAIR OF DAMAGE CAUSE TO THE PADS DURING FABRICATION, LIFTING AND HANDLING, OR TRANSPORTATION SHALL BE ADDRESSED ON A CASE-BY-CASE BASIS. DAMAGE WITHIN ACCEPTABLE LIMITS CAUSED TO THE TOP OF THE SURFACES OR TO KEYED EDGES OF THE PADS SHALL BE REPAIRED USING AN APPROVED REPAIR METHOD AT THE FABRICATION PLANT AT THE EXPENSE OF THE CONTRACTOR. REPETITIVE DAMAGE TO THE PADS SHALL BE CAUSE FOR STOPPAGE OF FABRICATION OPERATION UNTIL CAUSE OF DAMAGE CAN BE REMEDIED.
- THE CONTRACTOR SHALL RETAIN THE SOLE RESPONSIBILITY FOR THE MEANS, METHODS, AND TECHNIQUES OF CONSTRUCTION OF THE PADS AND FOR COMPLIANCE WITH LAWS, REGULATIONS, AND CODES, AND FOR THE SAFETY OF CONSTRUCTION APPLICABLE TO THIS WORK.

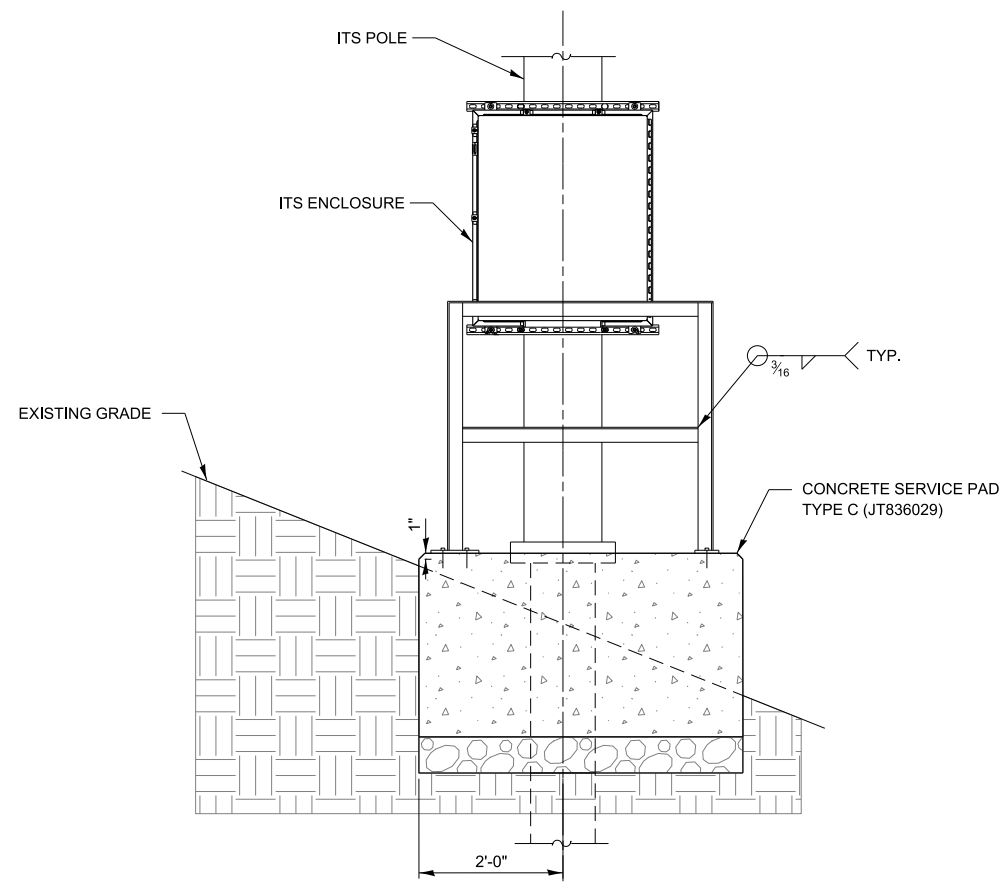

**CONCRETE SERVICE PAD, TYPE C
ELEVATION VIEW**

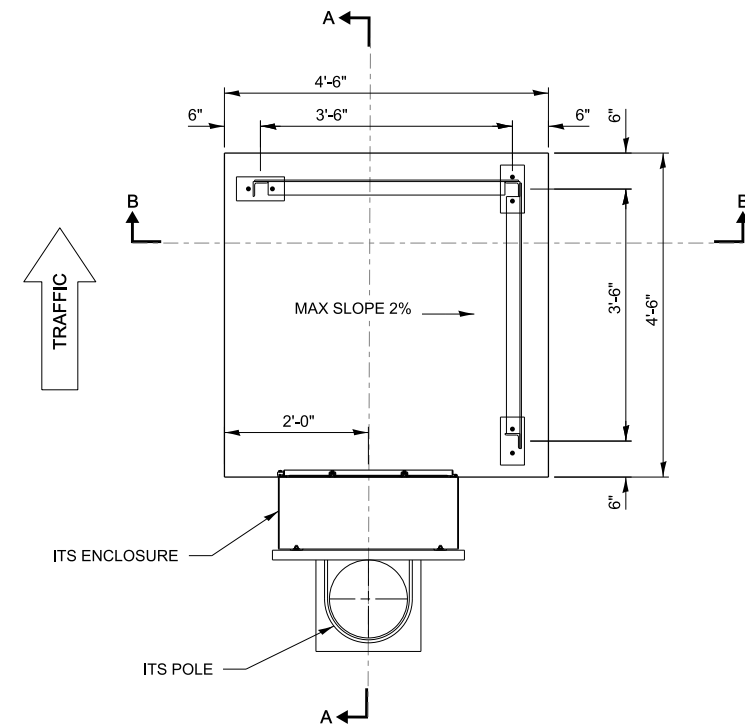

**CONCRETE SERVICE PAD, TYPE C
PLAN VIEW**

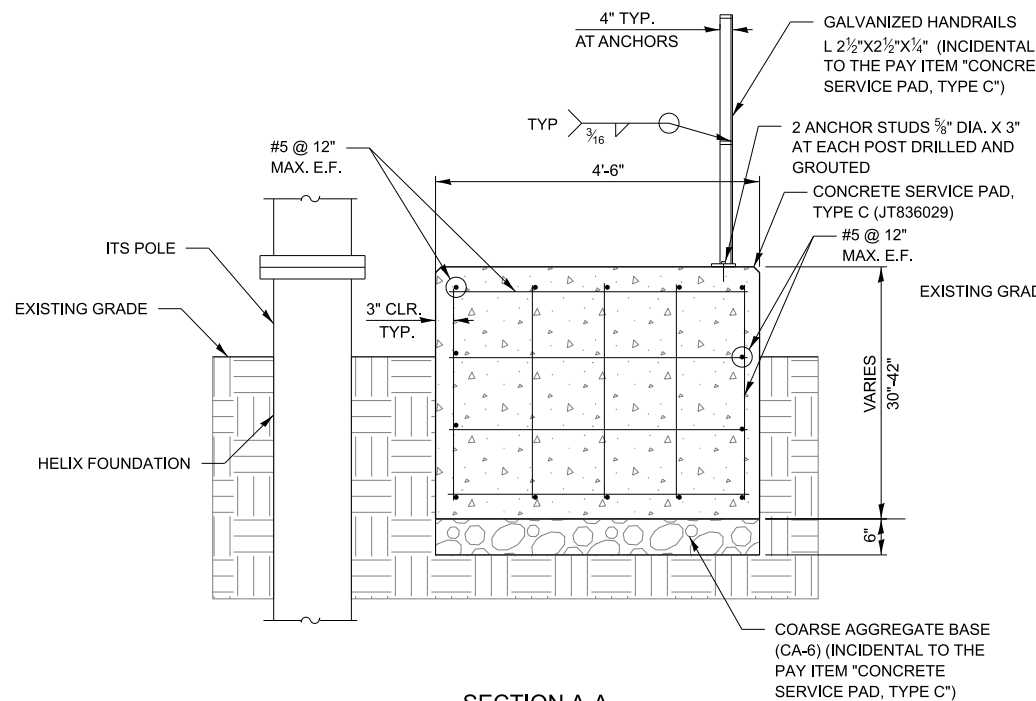

SECTION A-A

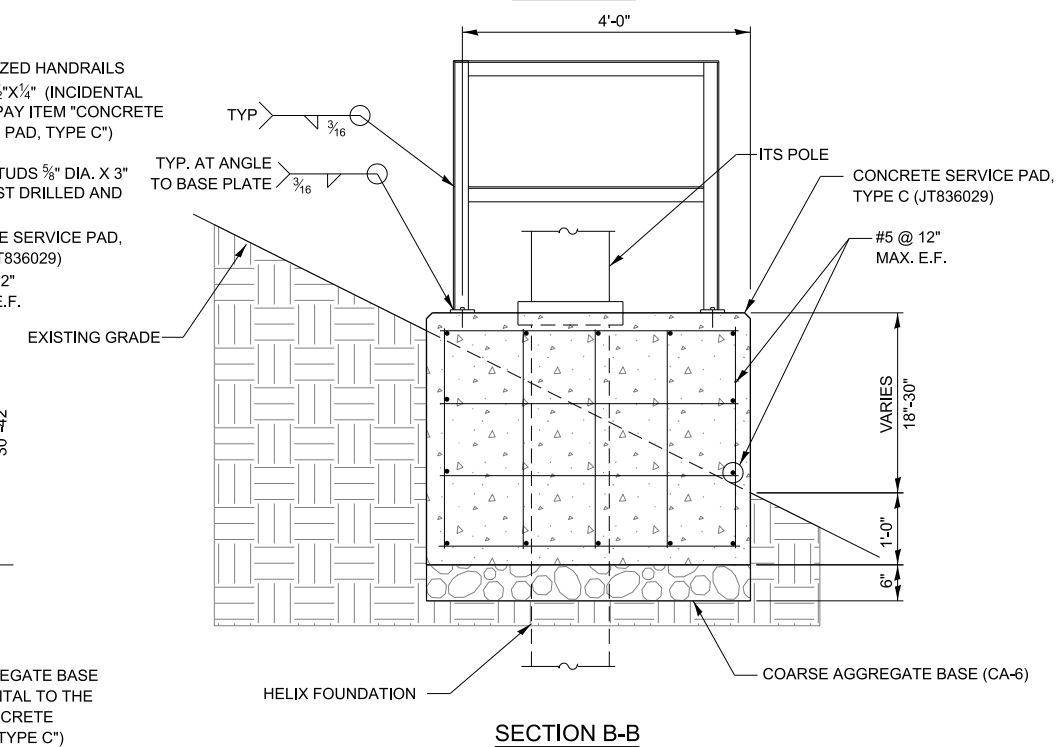

SECTION B-B

DESIGN STRESSES

CONCRETE

CAST-IN-PLACE: $f_c = 3,500$ PSI AT 14 DAYS (CLASS SI)
 PRE-CAST: $f_c = 3,500$ PSI AT 5 DAYS, $f_c = 5,000$ PSI AT 28 DAYS (CLASS PC)

STEEL

ASTM A615, GRADE 60 DEFORMED: $F_y = 60,000$ PSI (EPOXY COATED)
 OR
 WELDED WIRE MESH: $F_y = 60,000$ PSI 6x6 D14

NOTE TO DESIGNER

THIS BASE SHEET SHOWS TYPICAL CONSTRUCTION BUT IT IS NOT A STANDARD DRAWING. IT REQUIRES COMPLETION BY THE DESIGNER PRIOR TO INSERTION INTO A CONTRACT. MICROSTATION FILES AND THE "CADD STANDARDS MANUAL" ARE AVAILABLE ON THE ILLINOIS TOLLWAY WEBSITE. THE DESIGNER SHALL ACCEPT THE RESPONSIBILITY OF THE DESIGN OF THIS SHEET UPON ITS COMPLETION AND INSERTION INTO A CONTRACT. ALL "NOTE TO DESIGNER" BOXES SHALL BE REMOVED BY THE DESIGNER PRIOR TO INSERTION OF THE SHEET INTO THE PLAN SET.



ITS CONCRETE SERVICE PAD

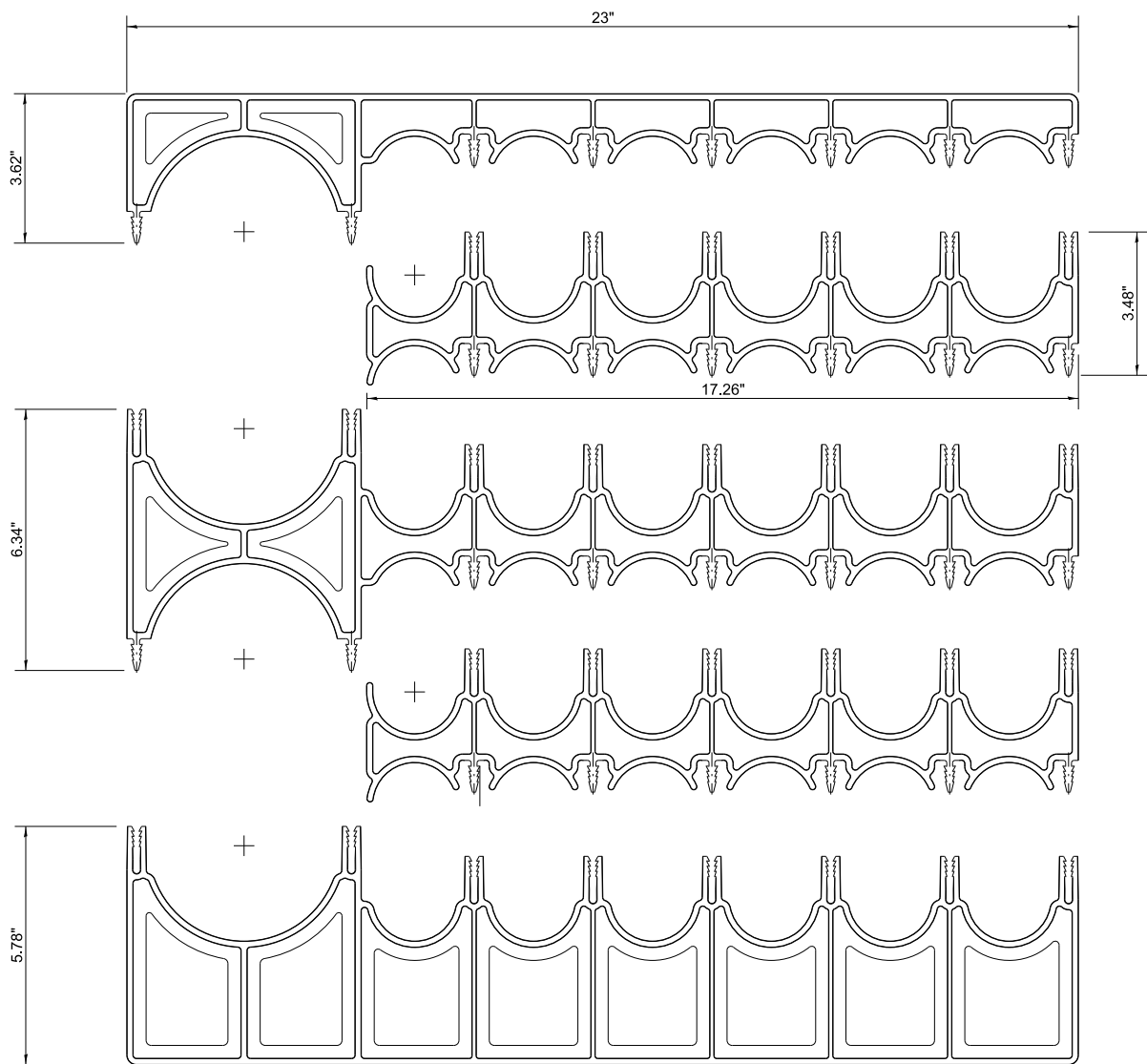
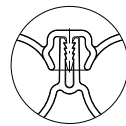

INTERLOCKING CONDUIT SPACER SYSTEM

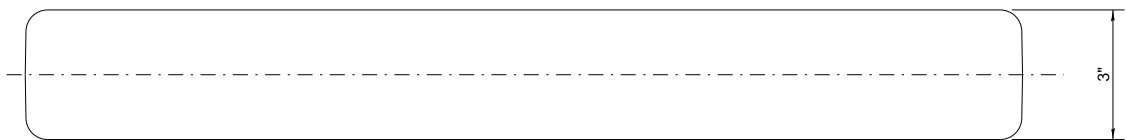

BOTTOM VIEW

NOTES:

1. THIS IS A REPRESENTATION ONLY. THE DSE HAS TO ADAPT THE NUMBER OF CONDUIT PER THE DESIGN.
2. CONTROLLED LOW STRENGTH MATERIAL (CLSM) SHALL BE PLACED A MINIMUM OF 3-INCHES TO THE SIDE OF AND ABOVE THE INTERLOCKING CONDUIT SPACER SYSTEM.

DUCT BANK SPACER DETAILS

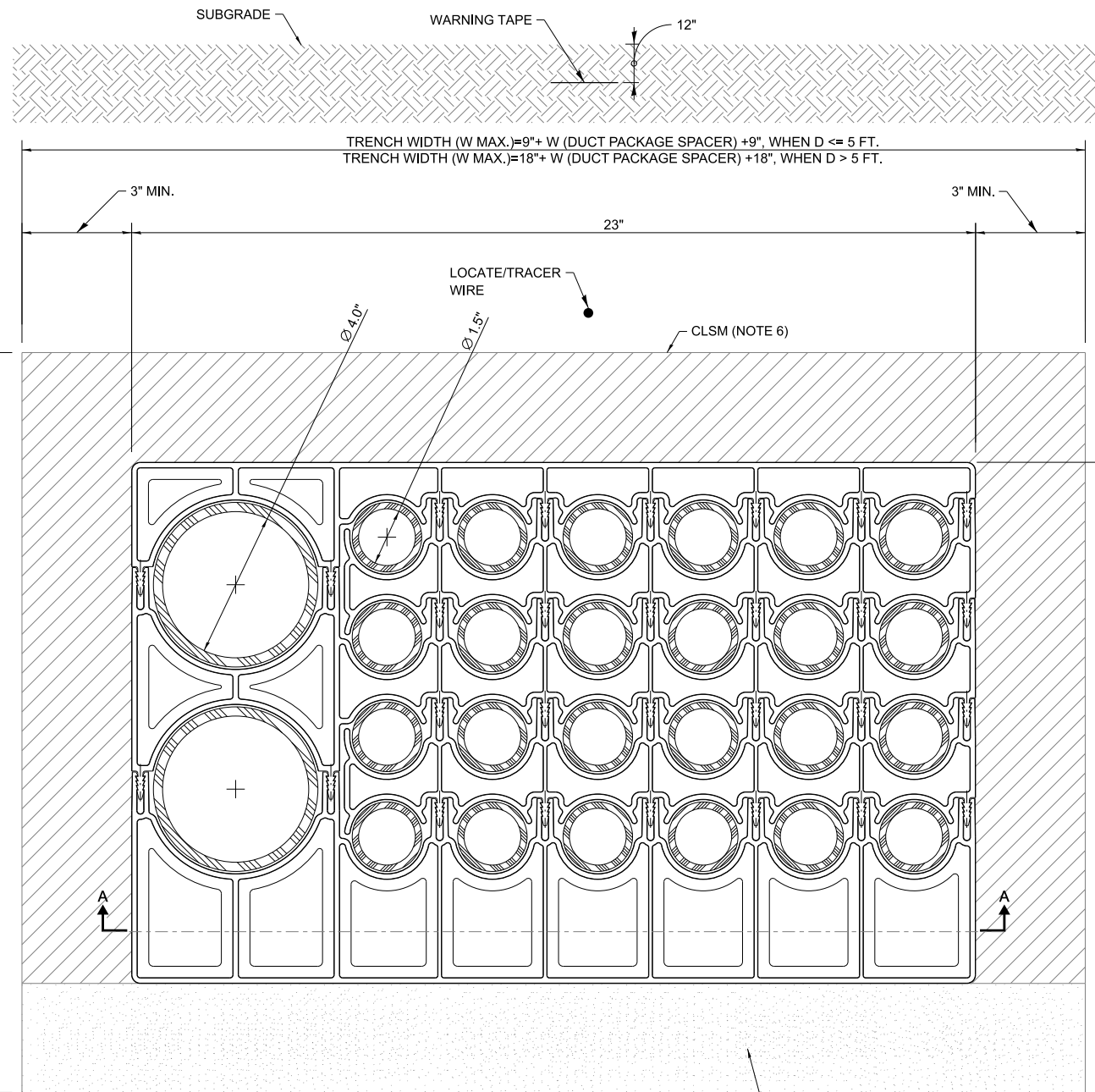

FRONT VIEW

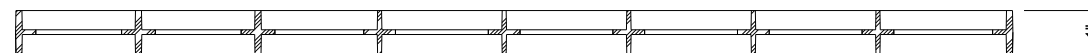

SECTION A-A

NOTES:

1. USE ONE SOLID PIECE SPACER (UNDERGROUND DEVICES BS13666SS OR APPROVED EQUAL) AT 5 FOOT INTERVALS FOR 30 FEET ON EACH SIDE OF EACH CONDUIT JOINT (MEANING 6 SOLID PIECE SPACERS ON EACH SIDE OF EACH JOINT).
2. USE ONE CRAB CLAW SPACER (UNDERGROUND DEVICES B51086355 OR APPROVED EQUAL) AT 5 FOOT INTERVALS ALONG THE FULL LENGTH OF THE DUCT BANK (BETWEEN CONDUIT JOINTS).
3. EACH CRAB CLAW SPACER INCLUDES:
1 EA. LEVEL 1 BASE SPACER
2 EA. LEVEL 2 AND 4 SPACER
1 EA. LEVEL 3 SPACER
4. WHEN PLACING CONCRETE AROUND CONDUITS, ADJUST THE DELIVERY CHUTE SO THE FALL OF THE CONCRETE IS MINIMAL. POUR THE CONCRETE SLOWLY AND DISTRIBUTE IT EVENLY SO AS NOT TO DISLodge THE SPACERS.
5. THE DUCT BANK MUST BE HELD DOWN DURING AND IMMEDIATELY AFTER THE CONCRETE POUR. THIS IS NECESSARY DUE TO THE FLOATATION CAUSED BY DUCT BANK BUOYANCY AND CONCRETE CHURNING.
6. CONTROLLED LOW STRENGTH MATERIAL (CLSM) SHALL BE PLACED A MINIMUM OF 3 INCHES ON EACH SIDE OF, AND ABOVE THE INTERLOCKING CONDUIT SPACER SYSTEM.

NOTE TO DESIGNER
 THIS BASE SHEET SHOWS TYPICAL CONSTRUCTION BUT IT IS NOT A STANDARD DRAWING. IT REQUIRES COMPLETION BY THE DESIGNER PRIOR TO INSERTION INTO A CONTRACT. MICROSTATION FILES AND THE "CADD STANDARDS MANUAL" ARE AVAILABLE ON THE ILLINOIS TOLLWAY WEBSITE. THE DESIGNER SHALL ACCEPT THE RESPONSIBILITY OF THE DESIGN OF THIS SHEET UPON ITS COMPLETION AND INSERTION INTO A CONTRACT. ALL "NOTE TO DESIGNER" BOXES SHALL BE REMOVED BY THE DESIGNER PRIOR TO INSERTION OF THE SHEET INTO THE PLAN SET.

NOTE TO DESIGNER
 WHEN THE PROJECT REQUIRES TO BURY THE FIBER AND POWER CONDUITS INTO A DUCT BANK THEN SPECIFY HOW MANY FIBER CONDUIT AND HOW MANY POWER CONDUITS THE PROJECT WILL REQUIRE AND MODIFY THIS ARRANGEMENT TO FIT THE NUMBER OF CONDUITS IN THE TRENCH. REFER TO ILLINOIS TOLLWAY DUCT PACKAGE SPECIAL PROVISION FOR DETAILS



SPACER - DUCT PACKAGE IN A TRENCH