

Illinois Tollway Base Sheet Revisions
--

Section M		Base Sheet Drawings	
Drawing	Modification Summary	Effective: 03-01-2024	
Bridge (BRG)-Series 500			
M-BRG-525	SLOPE WALL DETAILS		
	Moved the shoulder line to the end of the slope wall		
M-BRG-529	STRUCTURE MOUNTED NOISE ABATEMENT WALL SCHEDULE		
Sheet 2	Added "FOR EACH WIDTH" to specialty panel naming convention. Publication dates of applicable design standards and construction specifications are changed to 'xxxxxxx'. Designers are required to update the applicable publication dates of design standards and construction specifications.		
M-BRG-531	CENTRAL TRI-STATE STRUCTURE MOUNTED NOISE ABATEMENT WALL SCHEDULE		
Sheet 3	Added "FOR EACH WIDTH" to specialty panel naming convention. Publication dates of applicable design standards and construction specifications are changed to 'xxxxxxx'. Designers are required to update the applicable publication dates of design standards and construction specifications.		
M-BRG-532	GROUND MOUNTED NOISE ABATEMENT WALL SCHEDULE		
Sheet 2	Added "FOR EACH WIDTH" to specialty panel naming convention. Publication dates of applicable design standards and construction specifications are changed to 'xxxxxxx'. Designers are required to update the applicable publication dates of design standards and construction specifications.		

 New Sheet

 Retired Standard

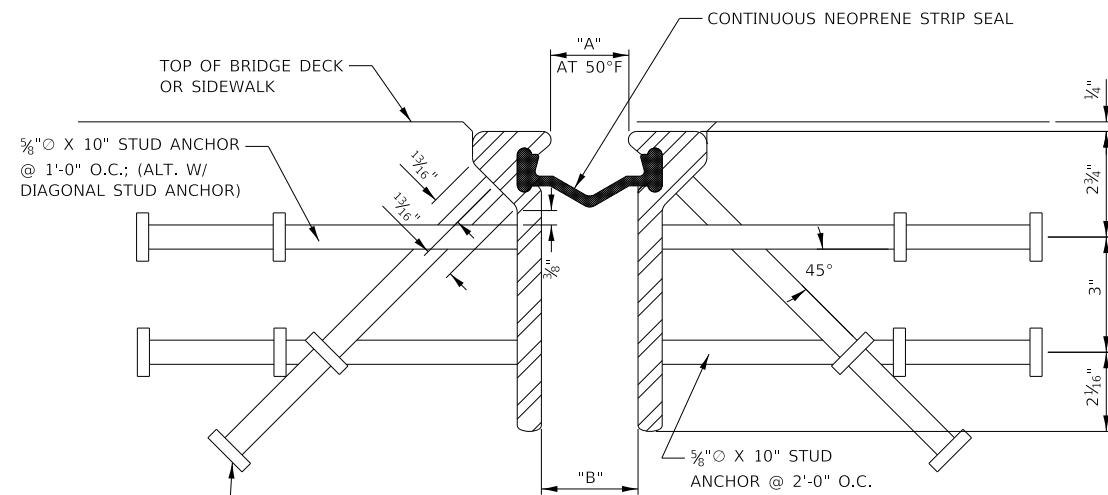

5/8" X 10" STUD ANCHOR @ 1'-0" O.C.; (ALT. W/ TOP HORIZ. STUD ANCHOR)

NOTE:
DIMENSIONS "A" AND "B" ARE PERPENDICULAR TO THE EXPANSION JOINT

NOTE:
10" STUDS SHALL BE MADE OF (1)-6 3/16" & (1)-4 1/8" (LENGTH BEFORE WELDING) PIGGY-BACKED.

SECTION THRU EXPANSION JOINT

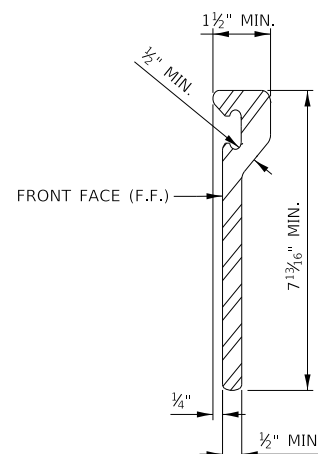

TYPICAL SECTION THRU FRAME RAIL

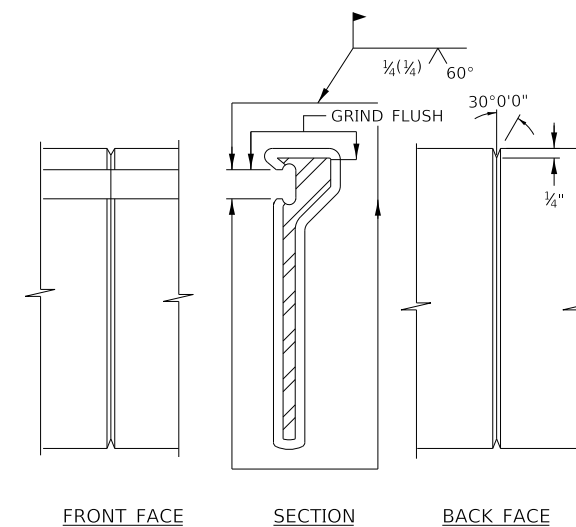

NOTE:
WELD ON FRONT SIDE OF FRAME MAY BE OMITTED AT STAGE CONSTRUCTION LINES.

FRAME RAIL SPlice DETAIL

NOTES:

- EXPANSION JOINT SHALL FOLLOW ROADWAY GRADE & CROSS SLOPE. EXPANSION JOINT TO BE SET TO GRADE BY ATTACHING FRAME RAILS TO BACKWALL AND BEAMS.
- FRAME RAILS AND OTHER STEEL SHALL BE AASHTO M270 GRADE 36, (ASTM A36).
- STUD ANCHORS SHALL BE AASHTO M169 (ASTM A108).
- EXPANSION ANCHORS SHALL BE IN ACCORDANCE WITH THE ILLINOIS TOLLWAY SUPPLEMENTAL SPECIFICATIONS, SECTION 1211.
- FRAME RAIL ASSEMBLY SHALL BE FABRICATED IN 20 FT. MAXIMUM LENGTHS. SHOP AND FIELD SPLICES SHALL BE PLACED AT CROWN BREAKS, CONSTRUCTION STAGE LINES, AND TRANSVERSE BREAKS IN DECK.
- AT SPLICES, A CONTINUOUS GROUND SMOOTH WELD SHALL BE PROVIDED EXCEPT ON SURFACES IN LOCKING CONTACT WITH SEAL WHICH SHALL HAVE NO BURRS.
- ALL STUD ANCHORS TO BE ELECTRIC ARC END WELDED WITH COMPLETE FUSION.
- AFTER FABRICATION IS COMPLETE FRAME RAILS SHALL BE HOT DIPPED GALVANIZED IN ACCORDANCE WITH AASHTO M232 (ASTM A153).
- CORRESPONDING SECTIONS SHALL BE TEMPORARILY SHOP ASSEMBLED, CHECKED FOR FIT, AND MATCH MARKED WITH STENCIL AND BLACK PAINT FOR SHIPMENT.
- NEOPRENE SEAL SHALL BE CONTINUOUS. FACTORY VULCANIZED HORIZONTAL MITERS SHALL BE REQUIRED FOR ALL SKEWS.
- NEOPRENE SEAL SHALL BE INSTALLED CONTINUOUS, SPLICING OF SEAL IN THE FIELD IS NOT PERMITTED.
- NEOPRENE SEAL SHALL BE BONDED TO THE FRAME RAILS WITH AN ADHESIVE MEETING THE REQUIREMENTS OF ASTM D4070.
- SUPPORT PLATES, NUTS AND WASHERS CONNECTED TO FRAME RAILS SHALL BE HOT DIPPED GALVANIZED IN ACCORDANCE WITH AASHTO M111 AND M232 (ASTM A123 AND A153).
- SUPPORT PLATES ON STEEL GIRDERS SHALL BE WELDED IN ACCORDANCE WITH ARTICLES 505.04 (q) & 505.08 (n) OF THE IDOT STANDARD SPECIFICATIONS.
- FURNISHING AND INSTALLING EXPANSION JOINT FRAME RAIL SUPPORT SYSTEM SHALL BE INCLUDED IN THE COST OF BRIDGE EXPANSION JOINT SYSTEM.
- JOINT OPENINGS SHALL BE ADJUSTED IN ACCORDANCE WITH THE FIELD ENGINEER'S INSTRUCTIONS.
- UPON COMPLETION OF FIELD WELDING, THE CONTRACTOR SHALL CLEAN THE WELD AREA AND APPLY A COATING OF ORGANIC ZINC-RICH PAINT IN ACCORDANCE WITH SSPC-PS12.01.

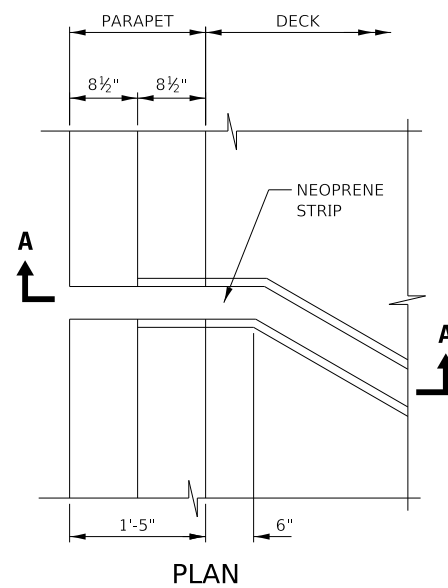

PLAN

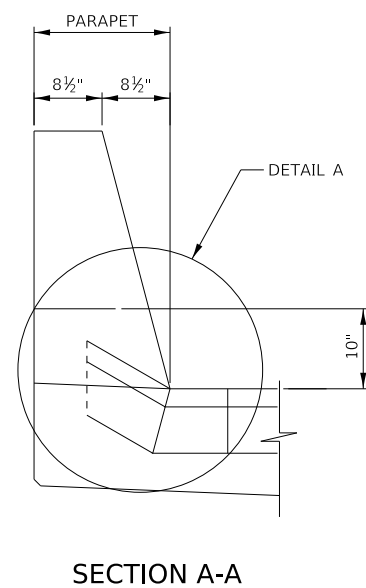

SECTION A-A

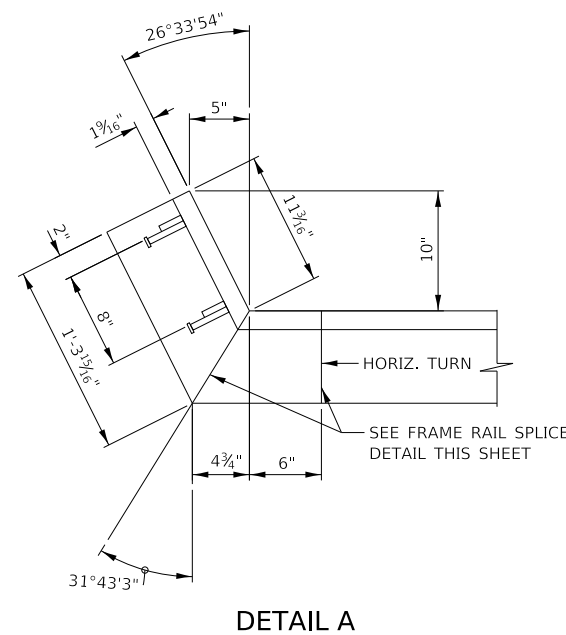

DETAIL A

NOTE TO DESIGNER
FOR SKEWS > 30° DESIGNER SHALL REPLACE PARAPET DETAILS SHOWN WITH SLIDING PLATE DETAILS ON THE LATEST IDOT BASE SHEET EJ-SS

NOTE TO DESIGNER
WORK THIS DRAWING WITH THE BASE SHEET FOR EXPANSION JOINT FRAME RAIL SUPPORT SYSTEM.

NOTE TO DESIGNER
THIS BASE SHEET SHOWS TYPICAL CONSTRUCTION BUT IT IS NOT A STANDARD DRAWING. IT REQUIRES COMPLETION BY THE DESIGNER PRIOR TO INSERTION INTO A CONTRACT. MICROSTATION FILES AND THE "CADD STANDARDS MANUAL" ARE AVAILABLE ON THE ILLINOIS TOLLWAY WEBSITE. THE DESIGNER SHALL ACCEPT THE RESPONSIBILITY OF THE DESIGN OF THIS SHEET UPON ITS COMPLETION AND INSERTION INTO A CONTRACT. ALL "NOTE TO DESIGNER" BOXES SHALL BE REMOVED BY THE DESIGNER PRIOR TO INSERTION OF THE SHEET INTO THE PLAN SET.



EXPANSION JOINT FRAME RAIL AND SEAL ALTERNATE A

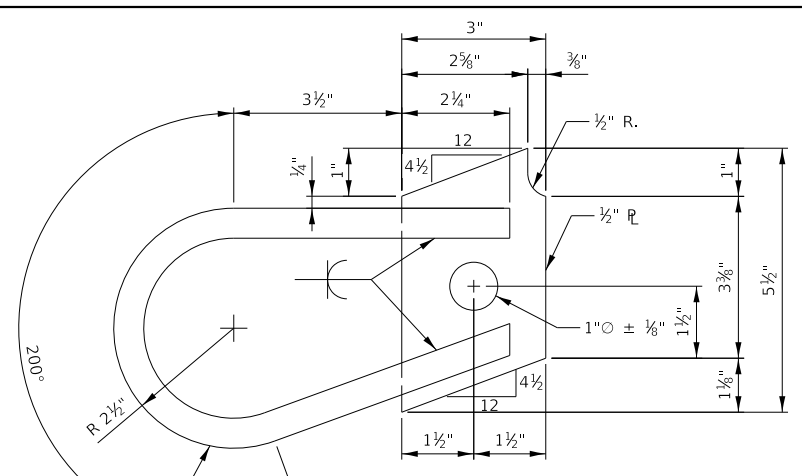

ANCHOR LUG DETAIL

#5 BAR
A615
GR. 60

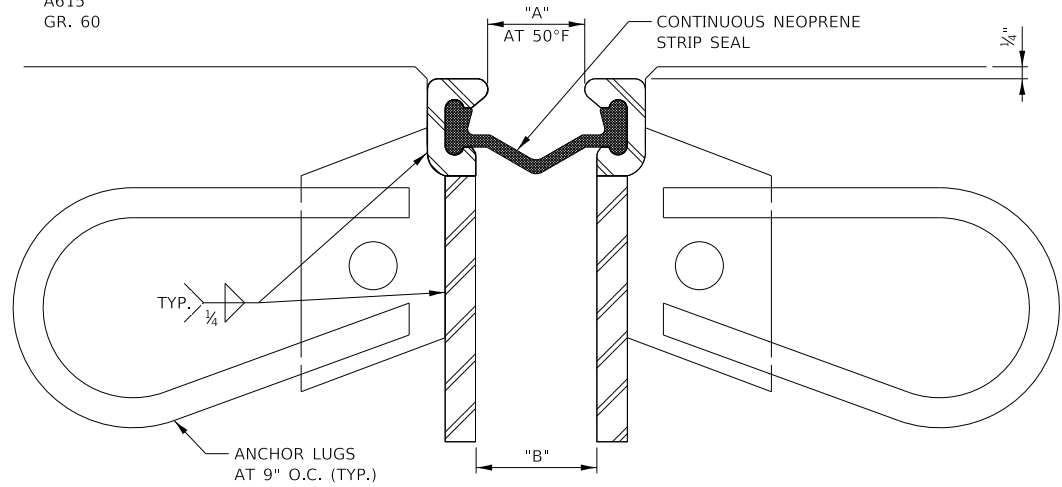

SECTION THRU EXPANSION JOINT

NOTE:
DIMENSIONS "A" AND "B" ARE PERPENDICULAR
TO THE EXPANSION JOINT

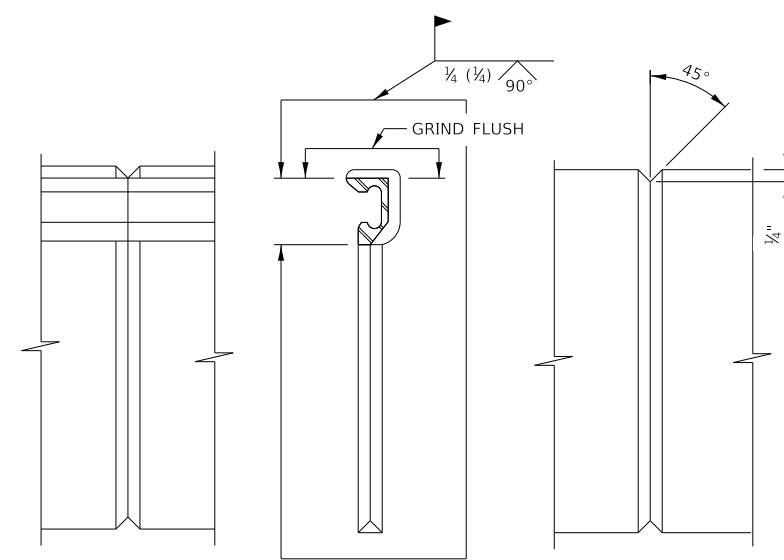

FRAME RAIL SPLICE DETAIL

NOTE:
WELD ON FRONT SIDE OF FRAME
MAY BE OMITTED AT STAGE
CONSTRUCTION LINES.

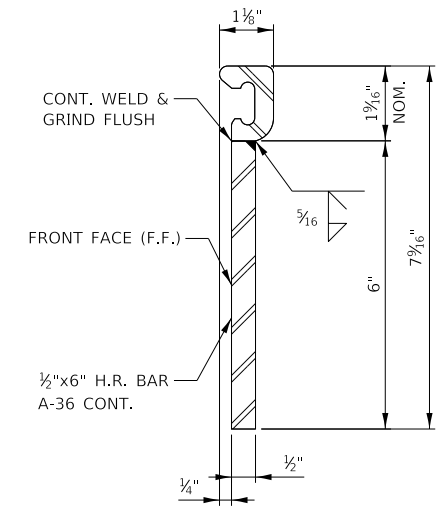

**TYPICAL SECTION
THRU FRAME RAIL**

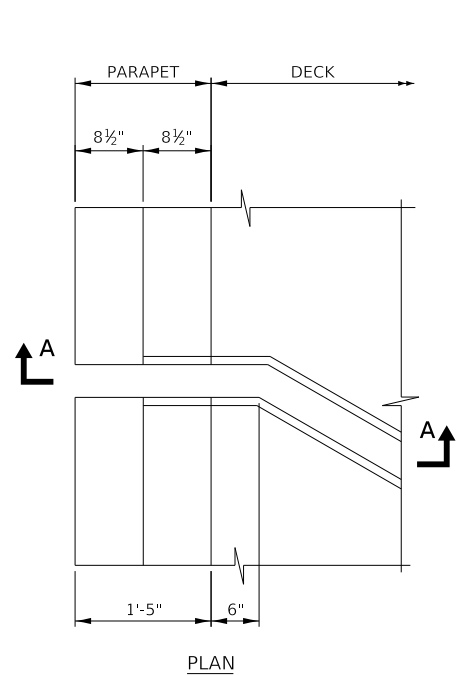

PLAN

UPTURN AT PARAPET

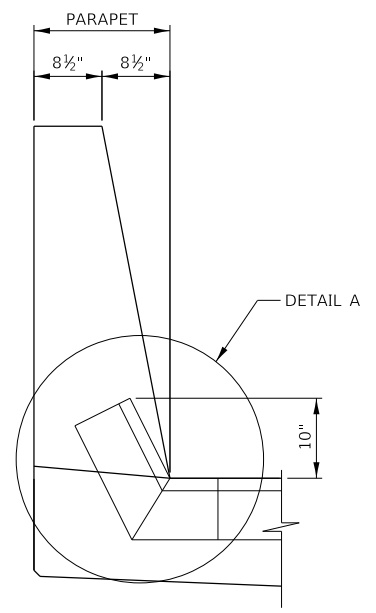

SECTION A-A

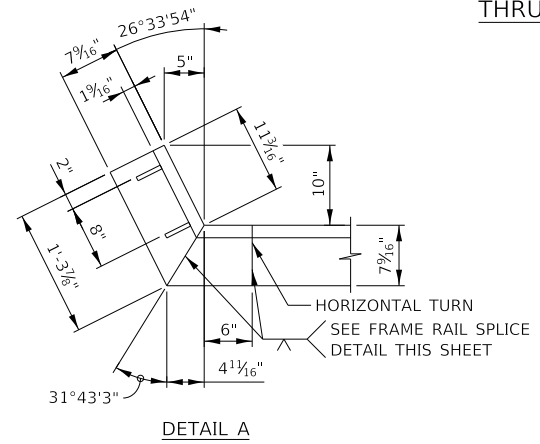

DETAIL A

NOTES:

1. EXPANSION JOINT SHALL FOLLOW ROADWAY GRADE & CROSS SLOPE. EXPANSION JOINT TO BE SET TO GRADE BY ATTACHING FRAME RAILS TO BACK WALL AND BEAMS.
2. AT SPLICES, A CONTINUOUS GROUND SMOOTH WELD SHALL BE PROVIDED EXCEPT ON SURFACES IN LOCKING CONTACT WITH SEAL WHICH SHALL HAVE NO BURRS.
3. FRAME RAILS AND OTHER STEEL SHALL BE AASHTO M270 GRADE 36, (ASTM A36).
4. ANCHOR LUGS SHALL BE AASHTO M31 (ASTM A615).
5. EXPANSION ANCHORS SHALL BE IN ACCORDANCE WITH THE ILLINOIS TOLLWAY SUPPLEMENTAL SPECIFICATIONS SECTION, 1211.
6. FRAME RAIL ASSEMBLY SHALL BE FABRICATED IN 20 FT. MAXIMUM LENGTHS. SHOP AND FIELD SPLICES SHALL BE PLACED AT CROWN BREAKS, CONSTRUCTION STAGE LINES, AND TRANSVERSE BREAKS IN DECK.
7. AFTER FABRICATION IS COMPLETE FRAME RAILS SHALL BE HOT DIPPED GALVANIZED IN ACCORDANCE WITH AASHTO M111 (ASTM A123).
8. CORRESPONDING SECTIONS SHALL BE TEMPORARILY SHOP ASSEMBLED, CHECKED FOR FIT, AND MATCH MARKED WITH STENCIL AND BLACK PAINT FOR SHIPMENT.
9. NEOPRENE SEAL SHALL BE CONTINUOUS. FACTORY VULCANIZED HORIZONTAL MITERS SHALL BE REQUIRED FOR ALL SKEWS.
10. NEOPRENE SEAL SHALL BE INSTALLED CONTINUOUS, SPlicing OF SEAL IN THE FIELD IS NOT PERMITTED.
11. NEOPRENE SEAL SHALL BE BONDED TO THE FRAME RAILS WITH AN ADHESIVE MEETING THE REQUIREMENTS OF ASTM D4070.
12. SUPPORT PLATES ON STEEL GIRDERS SHALL BE WELDED IN ACCORDANCE WITH ARTICLES 505.04 (q) & 505.08(n) OF THE IDOT STANDARD SPECIFICATIONS.
13. FURNISHING AND INSTALLING EXPANSION JOINT FRAME RAIL SUPPORT SYSTEM SHALL BE INCLUDED IN THE COST OF BRIDGE EXPANSION JOINT SYSTEM.
14. JOINT OPENINGS SHALL BE ADJUSTED IN ACCORDANCE WITH THE FIELD ENGINEER'S INSTRUCTIONS.
15. SUPPORT PLATES, NUTS, AND WASHERS CONNECTED TO FRAME RAILS SHALL BE HOT DIPPED GALVANIZED IN ACCORDANCE WITH AASHTO M111 AND M232 (ASTM A123 AND A153).
16. UPON COMPLETION OF FIELD WELDING, THE CONTRACTOR SHALL CLEAN THE WELD AREA AND APPLY A COATING OF ORGANIC ZINC-RICH PAINT IN ACCORDANCE WITH SSPC-P512.01.

NOTE TO DESIGNER

THIS BASE SHEET SHOWS TYPICAL CONSTRUCTION BUT IT IS NOT A STANDARD DRAWING. IT REQUIRES COMPLETION BY THE DESIGNER PRIOR TO INSERTION INTO A CONTRACT. MICROSTATION FILES AND THE "CADD STANDARDS MANUAL" ARE AVAILABLE ON THE ILLINOIS TOLLWAY WEBSITE. THE DESIGNER SHALL ACCEPT THE RESPONSIBILITY OF THE DESIGN OF THIS SHEET UPON ITS COMPLETION AND INSERTION INTO A CONTRACT. ALL "NOTE TO DESIGNER" BOXES SHALL BE REMOVED BY THE DESIGNER PRIOR TO INSERTION OF THE SHEET INTO THE PLAN SET.

NOTE TO DESIGNER

FOR SKEWS > 30°, DESIGNER SHALL REPLACE PARAPET DETAILS SHOWN WITH SLIDING PLATE DETAILS ON THE LATEST IDOT BASE SHEET EJ-55

WORK THIS DRAWING WITH THE BASE SHEET FOR EXPANSION JOINT FRAME RAIL SUPPORT SYSTEM.



EXPANSION JOINT FRAME RAIL AND SEAL ALTERNATE B

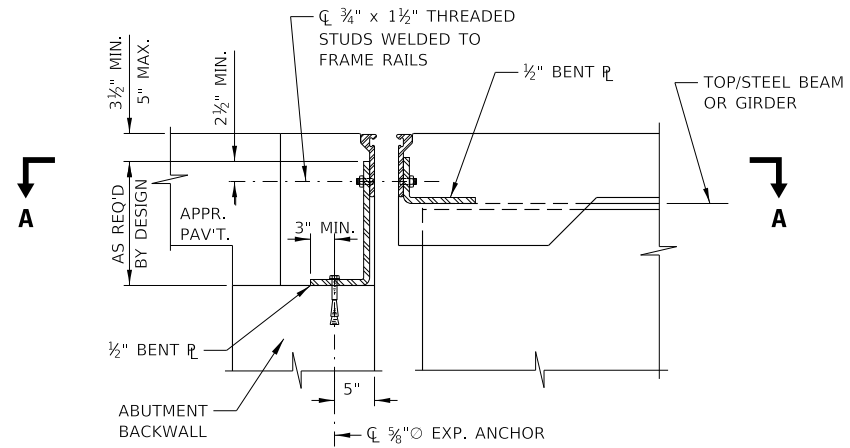

TYPICAL SECTION THRU EXP. JOINT AND SUPPORT SYSTEM AT STEEL GIRDERS

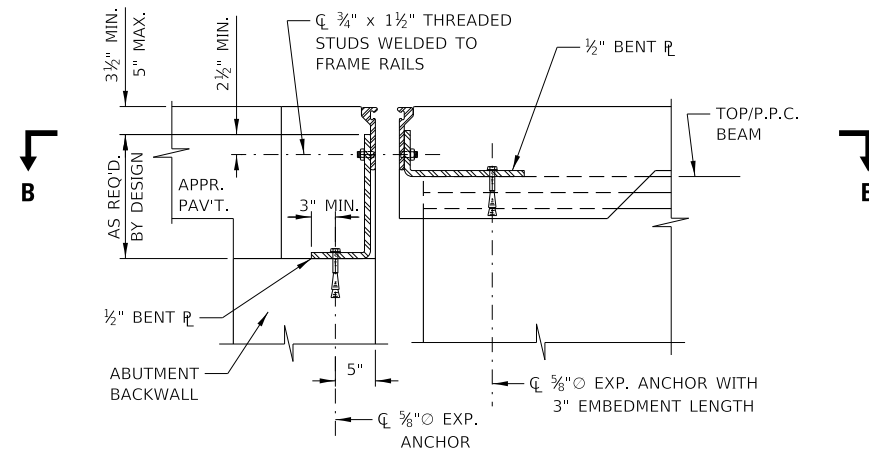

TYPICAL SECTION THRU EXP. JOINT AND SUPPORT SYSTEM AT P.P.C. BEAMS

NOTE:
DETAILS SHOWN ARE OPTIONAL. CONTRACTOR MAY SUBMIT AN ALTERNATIVE SUPPORT SYSTEM FOR APPROVAL.

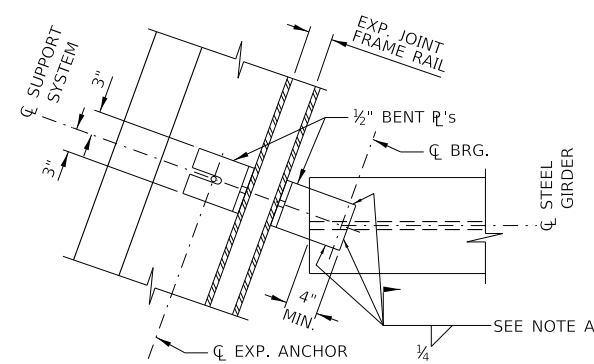

SECTION A-A

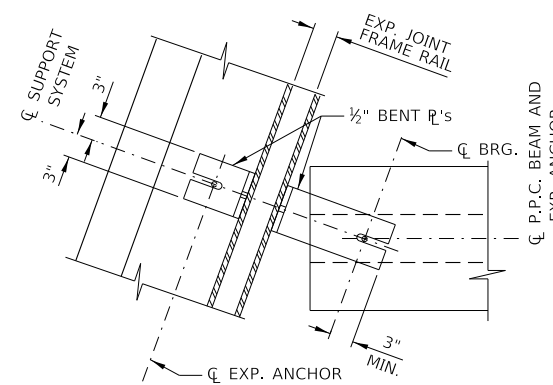

SECTION B-B

NOTE A:
FIELD WELD AFTER SUPPORT SYSTEM IS ADJUSTED FOR THE OPENING AND HEIGHT REQUIREMENTS AND THE BENT PLATE ON THE OPPOSITE SIDE IS SECURED IN PLACE WITH EXPANSION ANCHOR INTO THE CONCRETE.

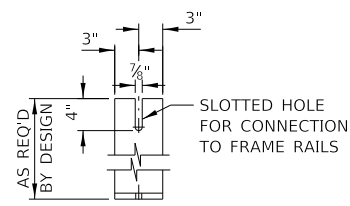

ELEVATION

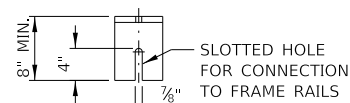

PLAN

BENT SUPPORT PLATE AT ABUTMENT

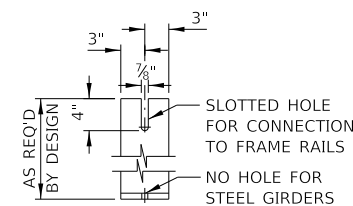

ELEVATION

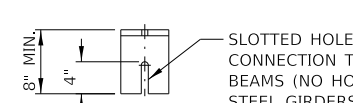

PLAN

BENT SUPPORT PLATE AT BRIDGE DECK

NOTE TO DESIGNER
THIS BASE SHEET SHOWS TYPICAL CONSTRUCTION BUT IT IS NOT A STANDARD DRAWING. IT REQUIRES COMPLETION BY THE DESIGNER PRIOR TO INSERTION INTO A CONTRACT. MICROSTATION FILES AND THE "CADD STANDARDS MANUAL" ARE AVAILABLE ON THE ILLINOIS TOLLWAY WEBSITE. THE DESIGNER SHALL ACCEPT THE RESPONSIBILITY OF THE DESIGN OF THIS SHEET UPON ITS COMPLETION AND INSERTION INTO A CONTRACT. ALL "NOTE TO DESIGNER" BOXES SHALL BE REMOVED BY THE DESIGNER PRIOR TO INSERTION OF THE SHEET INTO THE PLAN SET.

NOTE TO DESIGNER
WORK THIS DRAWING WITH THE BASE SHEETS M-BRG-500 AND M-BRG-501 FOR EITHER EXPANSION JOINT FRAME RAIL AND SEAL ALTERNATIVE A OR ALTERNATIVE B



EXPANSION JOINT FRAME RAIL SUPPORT SYSTEM

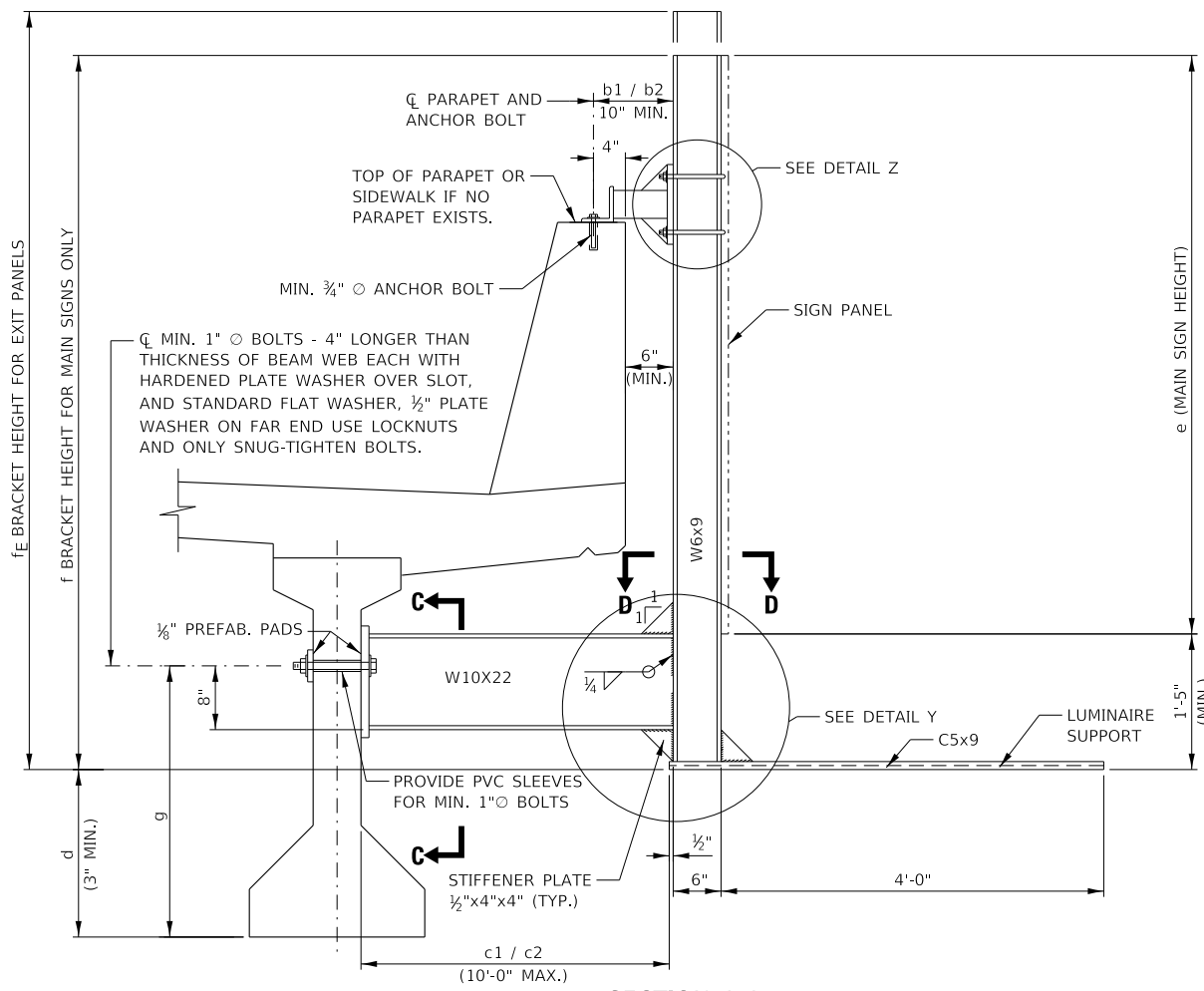

SECTION A-A

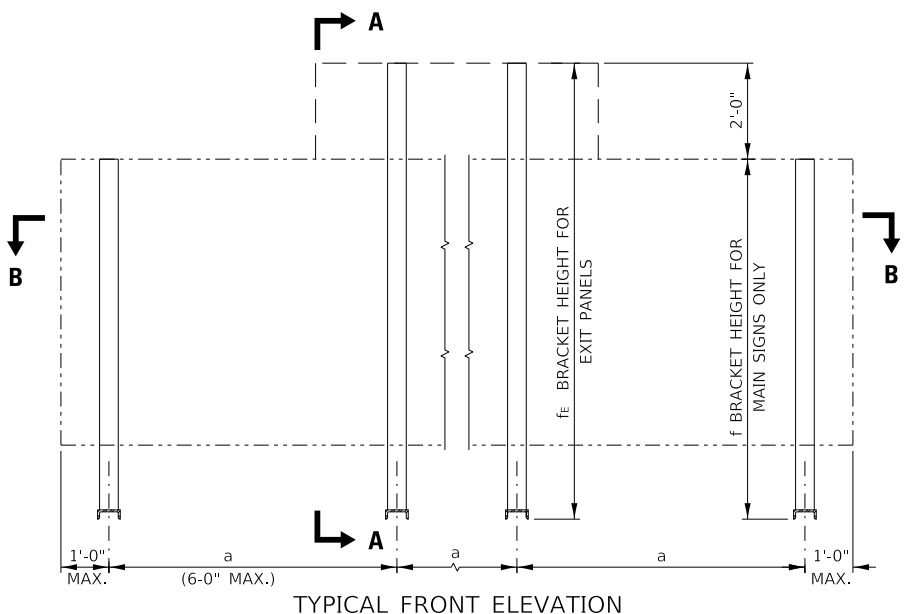

TYPICAL FRONT ELEVATION

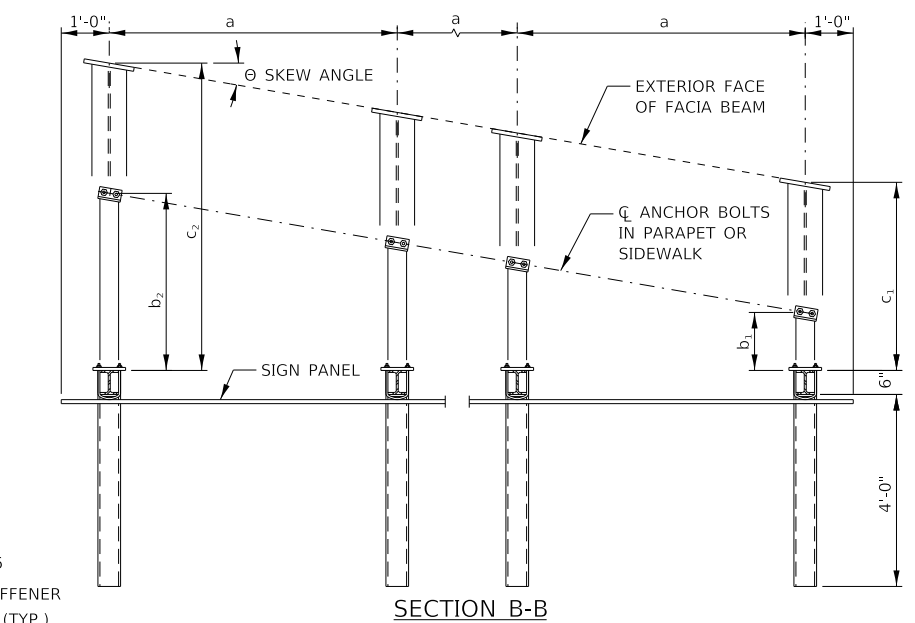

SECTION B-B

NOTES:

1. ALL STRUCTURE STEEL SHAPES AND PLATES SHALL CONFORM TO THE REQUIREMENTS OF ASTM A36 (AASHTO M-270).
2. ALL STRUCTURAL STEEL PIPE SHALL BE ASTM A53 TYPE E OR S GRADE B WITH A MINIMUM YIELD OF 35,000 PSI. IF ASTM A500 GRADE B PIPE IS SUBSTITUTED FOR A53 THEN THE OUTSIDE DIAMETER SHALL BE AS DETAILED AND THE WALL THICKNESS GREATER THAN OR EQUAL TO ASTM A53.
3. ALL CAP SCREWS, BOLTS, U-BOLTS, WASHERS AND LOCKNUTS SHALL BE IN ACCORDANCE WITH ARTICLE 733.02 OF THE IDOT STANDARD SPECIFICATIONS AND SHALL BE GALVANIZED IN ACCORDANCE WITH ASTM A153 AASHTO M-232.
4. ALL-THREADED RODS SHALL CONFIRM TO ASTM F1554 GRADE 105, EACH WITH ONE PLATE WASHER AND LOCKNUT AND BE HOT DIP GALVANIZED PER ASTM A153 (AASHTO M232). THEY SHALL BE INSTALLED IN ACCORDANCE WITH SECTION 1211 OF ILLINOIS TOLLWAY SUPPLEMENTAL SPECIFICATION TO THE IDOT STANDARD SPECIFICATION.
5. ALL WELDS TO BE CONTINUOUS UNLESS OTHERWISE SHOWN. ALL WELDING TO BE DONE IN ACCORDANCE WITH THE CURRENT AWS D1.1 STRUCTURAL WELDING CODE (STEEL) AND THE ILLINOIS TOLLWAY SUPPLEMENTAL SPECIFICATIONS.
6. ALL FABRICATION SHALL BE COMPLETE AND READY FOR ASSEMBLY BEFORE GALVANIZING. NO PUNCHING, DRILLING, CUTTING, NOR WELDING SHALL BE PERMITTED AFTER GALVANIZING.
7. ALL STRUCTURAL STEEL PLATES, SHAPES AND PIPE SHALL BE HOT-DIPPED GALVANIZED IN ACCORDANCE WITH ASTM A123 AND ASTM A123 AND ASTM A325 AASHTO M111. PAINTING IS NOT PERMITTED.
8. CONTRACTOR SHALL FIELD CHECK ALL BRIDGE DIMENSIONS SHOWN ON PLANS BEFORE SUBMITTING SHOP DRAWINGS. DRAWINGS SHALL BE PREPARED IN ACCORDANCE TO ARTICLE 505.03 OF STANDARD SPECIFICATIONS.
9. THE COST OF FURNISHING AND INSTALLING THE BEARING PADS AS HEREIN SPECIFIED SHALL BE INCLUDED WITH THE COST OF BRIDGE (CONCRETE) MOUNTED SIGN SUPPORT.
10. PRE-FAB BEARING PADS: NEOPRENE BEARING PADS SHALL HAVE A SHORE DUROMETER SURFACE HARDNESS OF 65.
11. METHOD OF MEASUREMENT SHALL BE IN ACCORDANCE WITH ARTICLE 733.10 OF THE ILLINOIS TOLLWAY SUPPLEMENTAL SPECIFICATIONS. THIS WORK SHALL BE PAID FOR AT THE CONTRACT UNIT PRICE PER LINEAR FOOT IN ACCORDANCE WITH ARTICLE 733.11 FOR BRIDGE (CONCRETE) MOUNTED SIGN SUPPORT.
12. SIGN STRUCTURE WIRING SHALL BE IN ACCORDANCE WITH THE ILLINOIS TOLLWAY SUPPLEMENTAL SPECIFICATIONS, SECTION 823.
13. CENTER LINE OF EXPANSION ANCHOR INTO PARAPET SHALL BE AT LEAST 12" TO CENTERLINE OF OPEN JOINT IN PARAPET. ENGINEER SHALL VERIFY THE MINIMUM DISTANCES BETWEEN EXPANSION ANCHORS AND PARAPET PRIOR TO ERECTION OF SIGN SUPPORT.

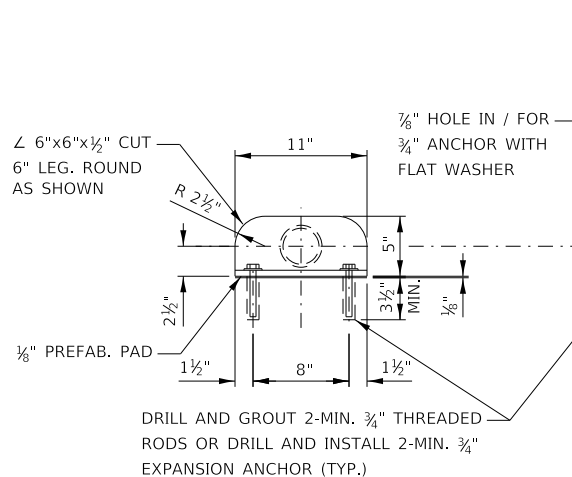

SECTION F-F

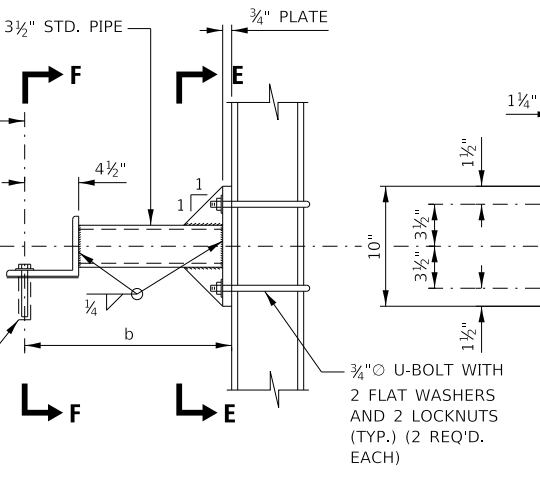

DETAIL Z

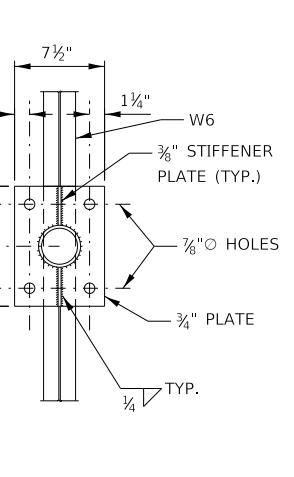

SECTION E-E

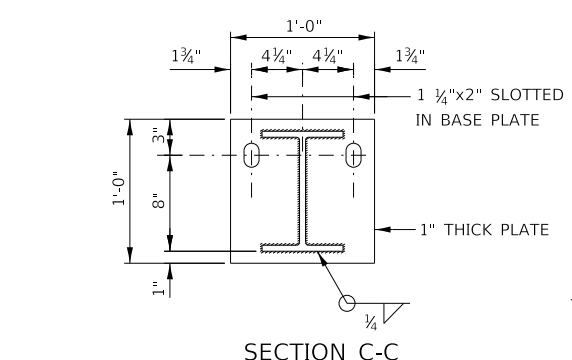

SECTION C-C

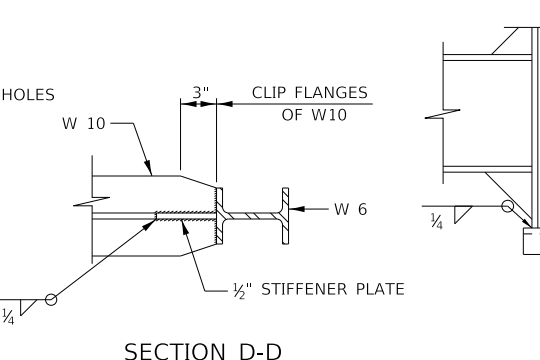

SECTION D-D

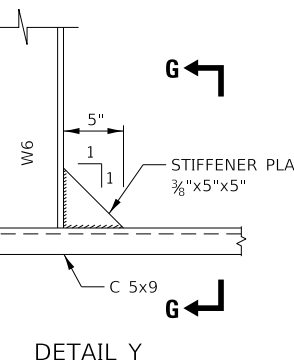

DETAIL Y

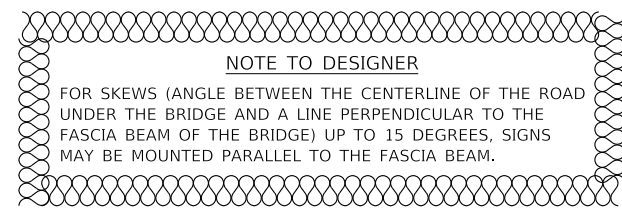

NOTE TO DESIGNER
FOR SKEWS (ANGLE BETWEEN THE CENTERLINE OF THE ROAD UNDER THE BRIDGE AND A LINE PERPENDICULAR TO THE FACIA BEAM OF THE BRIDGE) UP TO 15 DEGREES, SIGNS MAY BE MOUNTED PARALLEL TO THE FACIA BEAM.

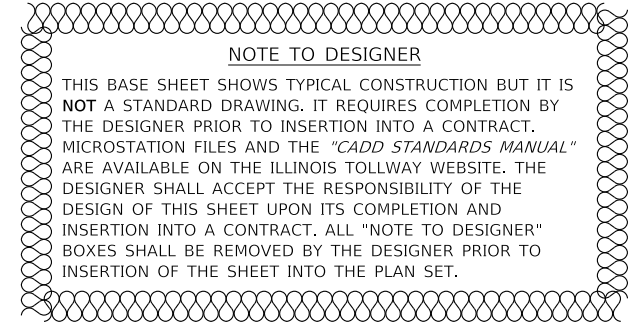

NOTE TO DESIGNER
THIS BASE SHEET SHOWS TYPICAL CONSTRUCTION BUT IT IS NOT A STANDARD DRAWING. IT REQUIRES COMPLETION BY THE DESIGNER PRIOR TO INSERTION INTO A CONTRACT. MICROSTATION FILES AND THE "CADD STANDARDS MANUAL" ARE AVAILABLE ON THE ILLINOIS TOLLWAY WEBSITE. THE DESIGNER SHALL ACCEPT THE RESPONSIBILITY OF THE DESIGN OF THIS SHEET UPON ITS COMPLETION AND INSERTION INTO A CONTRACT. ALL "NOTE TO DESIGNER" BOXES SHALL BE REMOVED BY THE DESIGNER PRIOR TO INSERTION OF THE SHEET INTO THE PLAN SET.

SIGN NO.	ROUTE	STATION	BRIDGE NAME	SIGN SKEW ANGLE (θ)	NO. BR'K'TS f	NO. BR'K'TS f	a	b ₁	b ₂	c ₁	c ₂	d	e	f	f _e	g	MAIN SIGN SIZE	EXIT PANEL WIDTH

TOTAL BILL OF MATERIAL			
PAY ITEM	DESCRIPTION	UNIT	TOTAL



BRIDGE (CONCRETE) MOUNTED SIGN SUPPORT

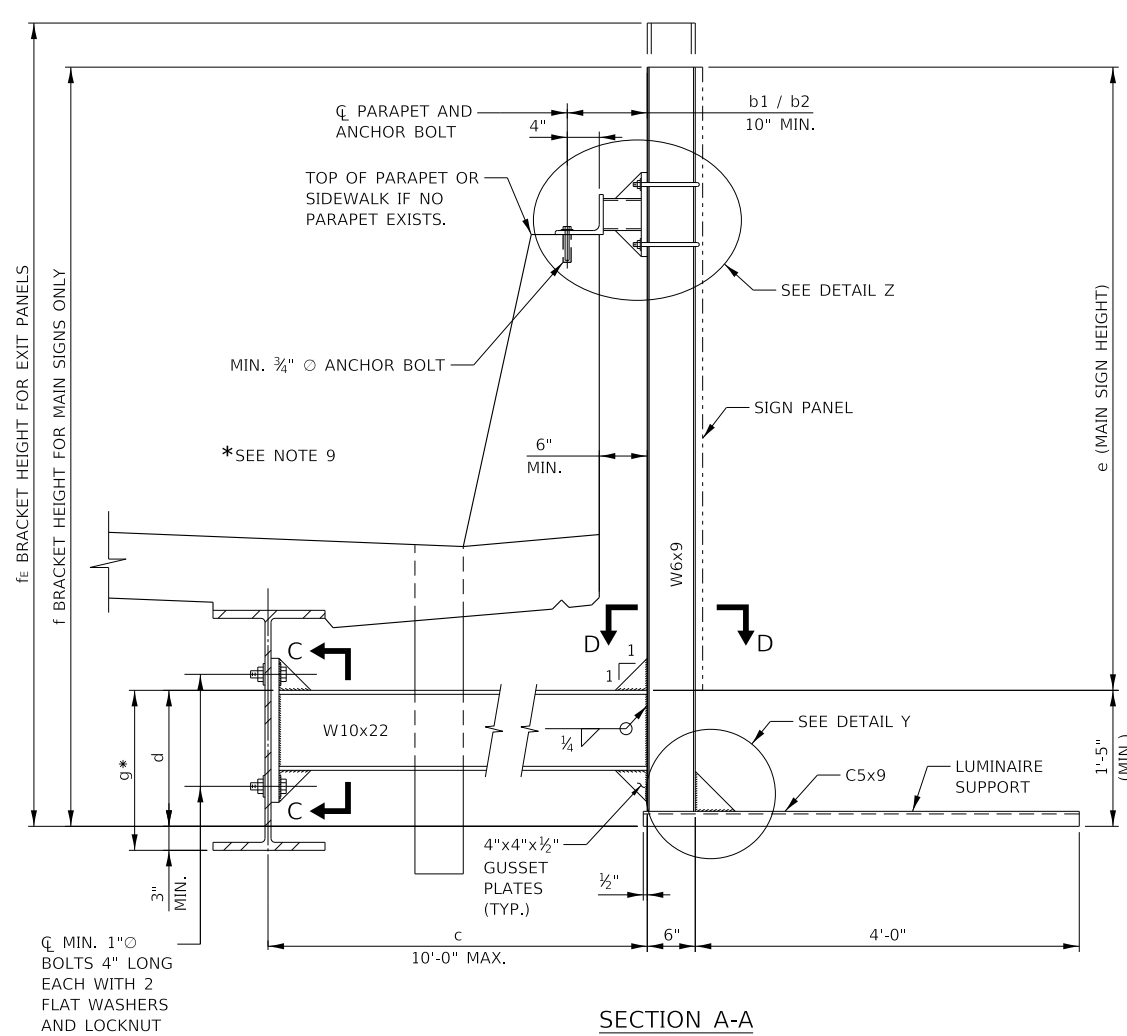

SECTION A-A

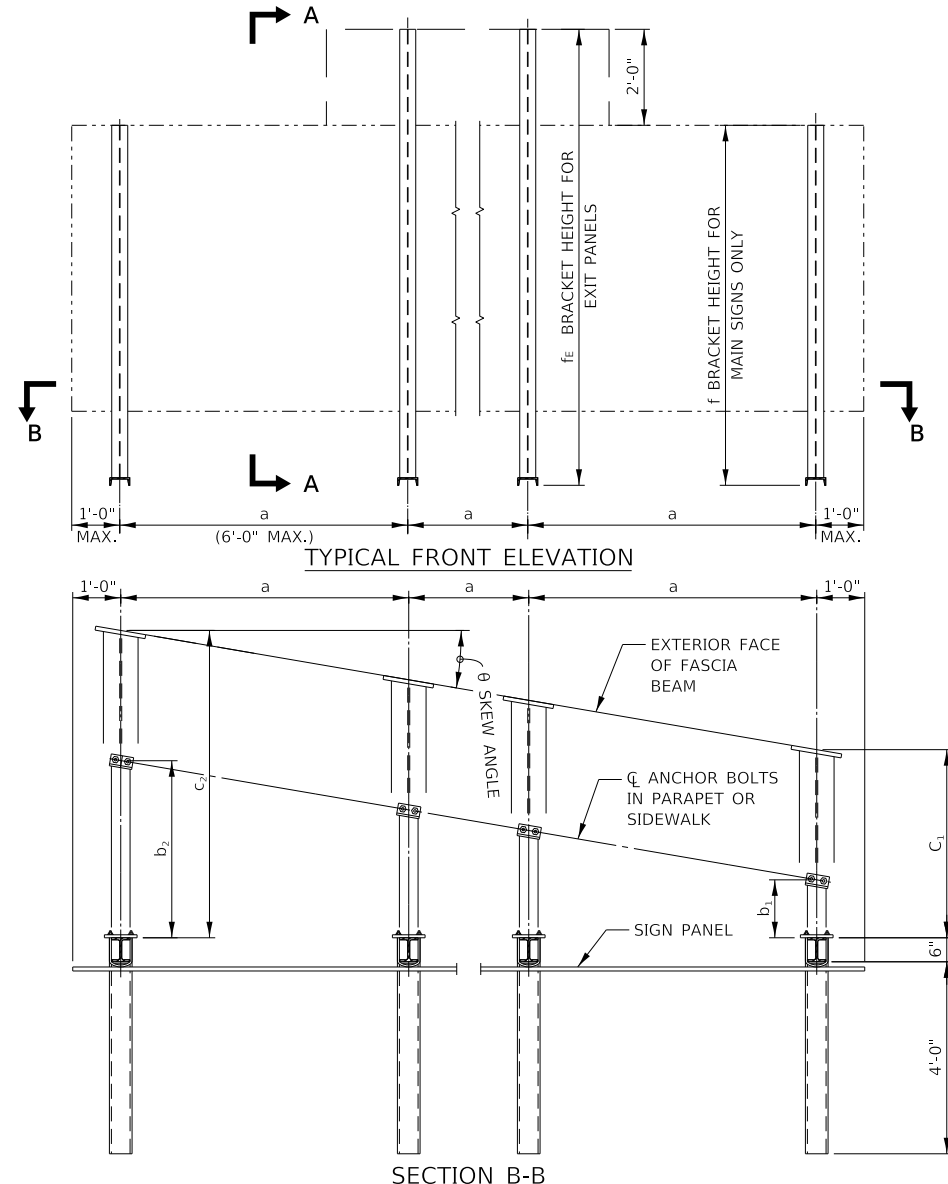

TYPICAL FRONT ELEVATION

SECTION B-B

NOTES:

1. ALL STRUCTURE STEEL SHAPES AND PLATES SHALL CONFORM TO THE REQUIREMENTS OF ASTM A36 (AASHTO M-270).
2. ALL STRUCTURAL STEEL PIPE SHALL BE ASTM A53 TYPE E OR S GRADE B WITH A MINIMUM YIELD OF 35,000 PSI. IF ASTM A500 GRADE B PIPE IS SUBSTITUTED FOR A53 THEN THE OUTSIDE DIAMETER SHALL BE AS DETAILED AND THE WALL THICKNESS GREATER THAN OR EQUAL TO ASTM A53.
3. ALL CAP SCREWS, BOLTS, U-BOLTS, WASHERS AND LOCKNUTS SHALL BE IN ACCORDANCE WITH ARTICLE 733.02 OF THE IDOT STANDARD SPECIFICATIONS AND SHALL BE GALVANIZED IN ACCORDANCE WITH ASTM A153 AASHTO M-232.
4. ALL-THREADED RODS SHALL CONFIRM TO ASTM F1554 GRADE 105, EACH WITH ONE PLATE WASHER AND LOCKNUT AND BE HOT DIP GALVANIZED PER ASTM A153 (AASHTO M232). THEY SHALL BE INSTALLED IN ACCORDANCE WITH SECTION 1211 OF ILLINOIS TOLLWAY SUPPLEMENTAL SPECIFICATION TO THE IDOT STANDARD SPECIFICATION.
5. ALL WELDS TO BE CONTINUOUS UNLESS OTHERWISE SHOWN. ALL WELDING TO BE DONE IN ACCORDANCE WITH THE CURRENT AWS D1.1 STRUCTURAL WELDING CODE (STEEL) AND THE ILLINOIS TOLLWAY SUPPLEMENTAL SPECIFICATIONS.
6. ALL FABRICATION SHALL BE COMPLETE AND READY FOR ASSEMBLY BEFORE GALVANIZING. NO PUNCHING, DRILLING, CUTTING, NOR WELDING SHALL BE PERMITTED AFTER GALVANIZING.
7. ALL STRUCTURAL STEEL PLATES, SHAPES AND PIPE SHALL BE HOT-DIPPED GALVANIZED IN ACCORDANCE WITH ASTM A123 AND ASTM A123 AND ASTM A325 AASHTO M111. PAINTING IS NOT PERMITTED.
8. CONTRACTOR SHALL FIELD CHECK ALL BRIDGE DIMENSIONS SHOWN ON PLANS BEFORE SUBMITTING SHOP DRAWINGS. DRAWINGS SHALL BE PREPARED IN ACCORDANCE TO ARTICLE 505.03 OF STANDARD SPECIFICATIONS.
9. ALL HOLES DRILLED IN BRIDGE BEAM OR PLATE GIRDER SHALL BE LOCATED IN THE MIDDLE HALF OF THE WEB. THERE SHALL NOT BE ANY HOLES DRILLED IN THE WEB OF BEAM OR PLATE GIRDER CLOSER TO THE FLANGE THAN THE DEPTH OF BEAM DIVIDED BY FOUR (4) OR ONE-FOURTH (1/4) THE DEPTH OF THE BEAM. THE ENGINEER MAY ADJUST DIMENSION "g" TO MEET THE ABOVE CONDITION AND TO KEEP THE SIGN LEVEL.
10. THE COST OF FURNISHING AND INSTALLING THE BEARING PADS AS HEREIN SPECIFIED SHALL BE INCLUDED WITH THE COST OF BRIDGE (STEEL) MOUNTED SIGN SUPPORT.
11. PRE-FAB BEARING PADS: NEOPRENE BEARING PADS SHALL HAVE A SHORE DUROMETER SURFACE HARDNESS OF 65.
12. METHOD OF MEASUREMENT SHALL BE IN ACCORDANCE WITH ARTICLE 733.10 OF THE ILLINOIS TOLLWAY SUPPLEMENTAL SPECIFICATIONS. THIS WORK SHALL BE PAID FOR AT THE CONTRACT UNIT PRICE PER LINEAR FOOT IN ACCORDANCE WITH ARTICLE 733.11 FOR BRIDGE (CONCRETE) MOUNTED SIGN SUPPORT.
13. SIGN STRUCTURE WIRING SHALL BE IN ACCORDANCE WITH THE ILLINOIS TOLLWAY SUPPLEMENTAL SPECIFICATIONS, SECTION 823.
14. CENTER LINE OF EXPANSION ANCHOR INTO PARAPET SHALL BE AT LEAST 12" TO CENTER LINE OF OPEN JOINT IN PARAPET. ENGINEER SHALL VERIFY THE MINIMUM DISTANCES BETWEEN EXPANSION ANCHORS & PARAPET PRIOR TO ERECTION OF SIGN SUPPORT.

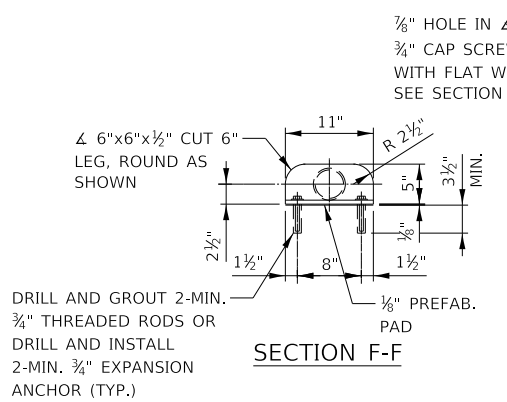

SECTION F-F

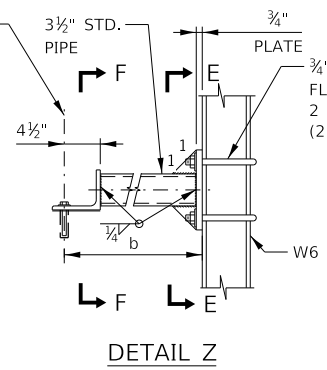

DETAIL Z

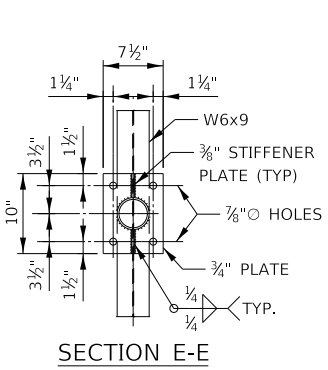

SECTION E-E

NOTE TO DESIGNER
FOR SKEWS (ANGLE BETWEEN THE CENTERLINE OF THE ROAD UNDER THE BRIDGE AND A LINE PERPENDICULAR TO THE FASCIA BEAM OF THE BRIDGE) UP TO 15 DEGREES, SIGNS MAY BE MOUNTED PARALLEL TO THE FASCIA BEAM.

SIGN NO.	ROUTE	STATION	BRIDGE NAME	SIGN SKEW ANGLE (θ)	NO. BR'K'TS f	NO. BR'K'TS fe	a	b ₁	b ₂	c ₁	c ₂	d	e	f	fe	g	MAIN SIGN SIZE	EXIT PANEL WIDTH

NOTE TO DESIGNER
DIMENSION "a" TO TAKE INTO ACCOUNT LOCATION OF SPLICE PLATES ALONG FASCIA BEAM TO AVOID CONFLICTS WITH HORIZONTAL SIGN BRACE.

NOTE TO DESIGNER
THIS BASE SHEET SHOWS TYPICAL CONSTRUCTION BUT IT IS NOT A STANDARD DRAWING. IT REQUIRES COMPLETION BY THE DESIGNER PRIOR TO INSERTION INTO A CONTRACT. MICROSTATION FILES AND THE "CADD STANDARDS MANUAL" ARE AVAILABLE ON THE ILLINOIS TOLLWAY WEBSITE. THE DESIGNER SHALL ACCEPT THE RESPONSIBILITY OF THE DESIGN OF THIS SHEET UPON ITS COMPLETION AND INSERTION INTO A CONTRACT. ALL "NOTE TO DESIGNER" BOXES SHALL BE REMOVED BY THE DESIGNER PRIOR TO INSERTION OF THE SHEET INTO THE PLAN SET.

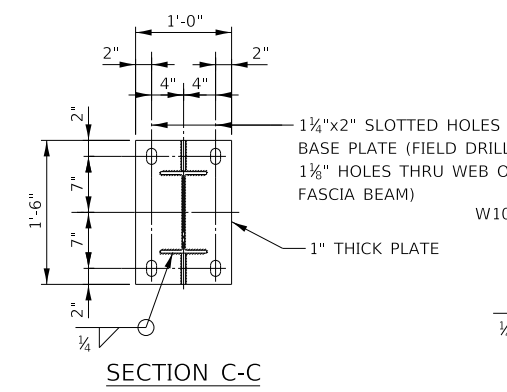

SECTION C-C

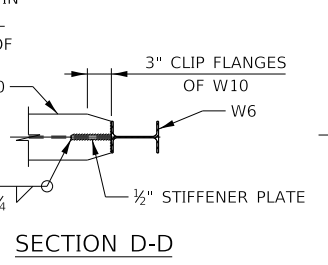

SECTION D-D

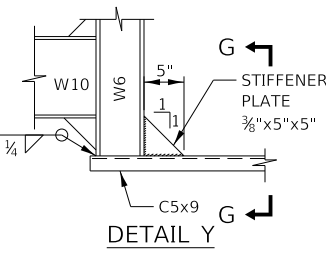

DETAIL Y

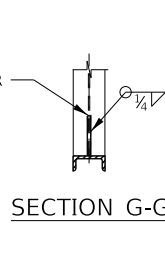

SECTION G-G

TOTAL BILL OF MATERIAL

PAY ITEM	DESCRIPTION	UNIT	TOTAL
XXX-XXXX			

BRIDGE (STEEL) MOUNTED SIGN SUPPORT

VERSION: 2022-03 STANDARD: M-BRG-504 SHEET: 1 OF 1

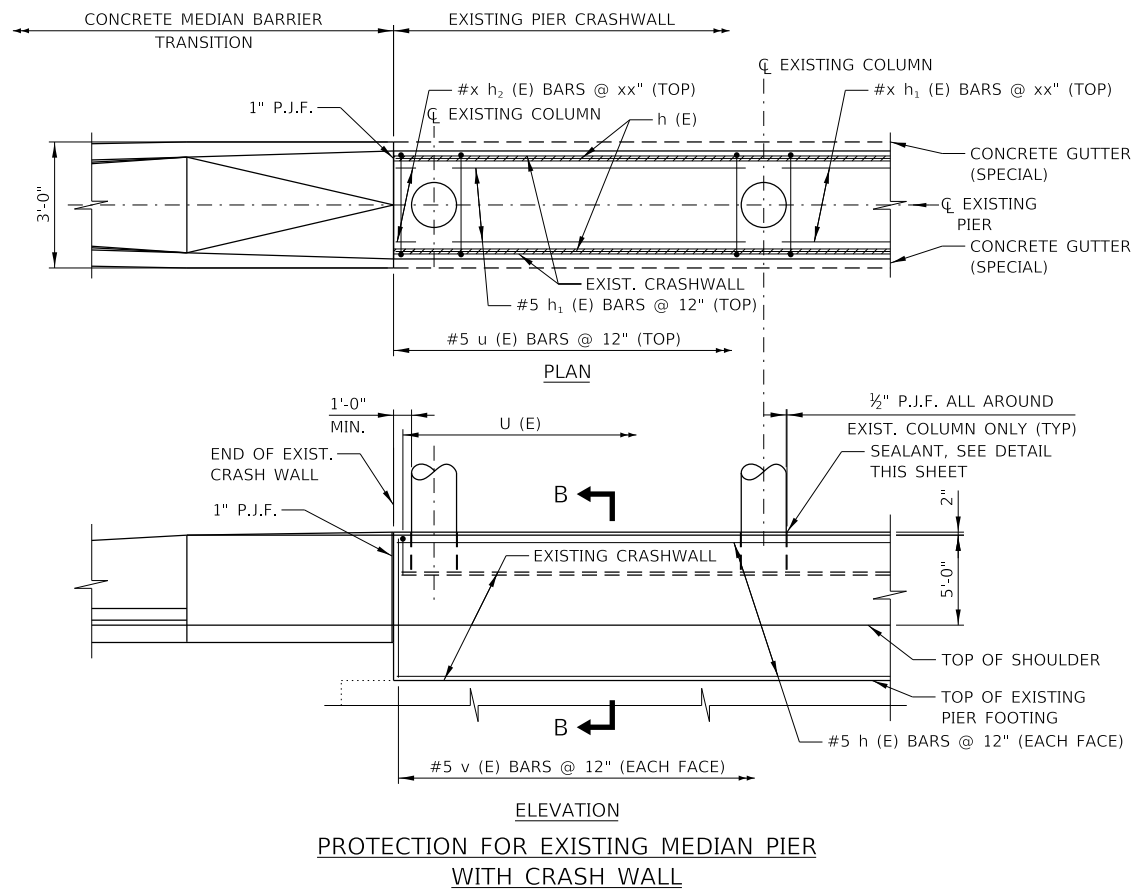

PROTECTION FOR EXISTING MEDIAN PIER WITH CRASH WALL

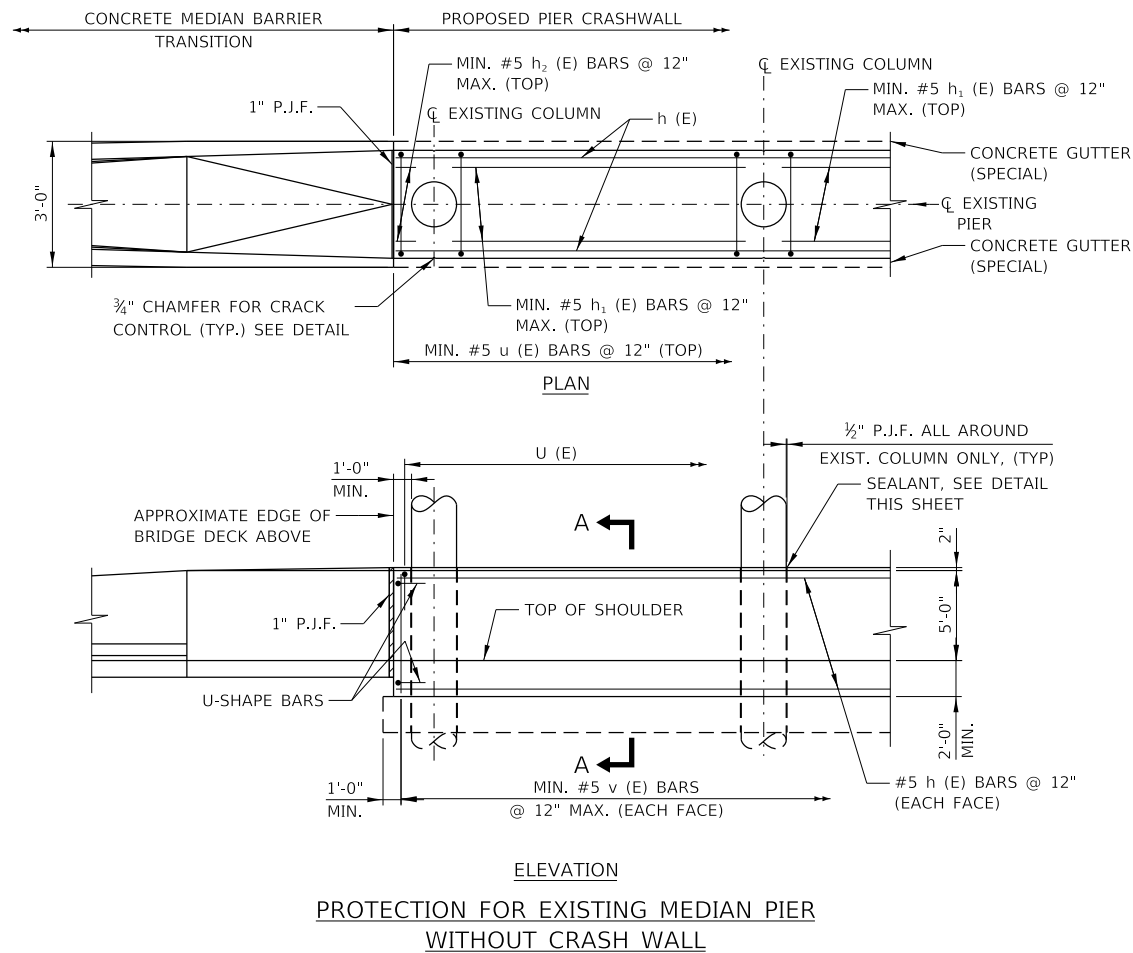

PROTECTION FOR EXISTING MEDIAN PIER WITHOUT CRASH WALL

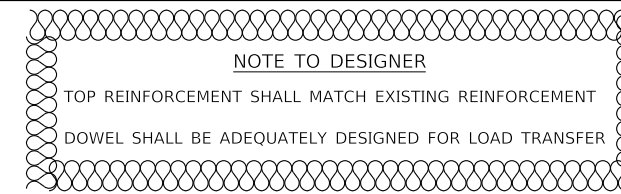

NOTE TO DESIGNER

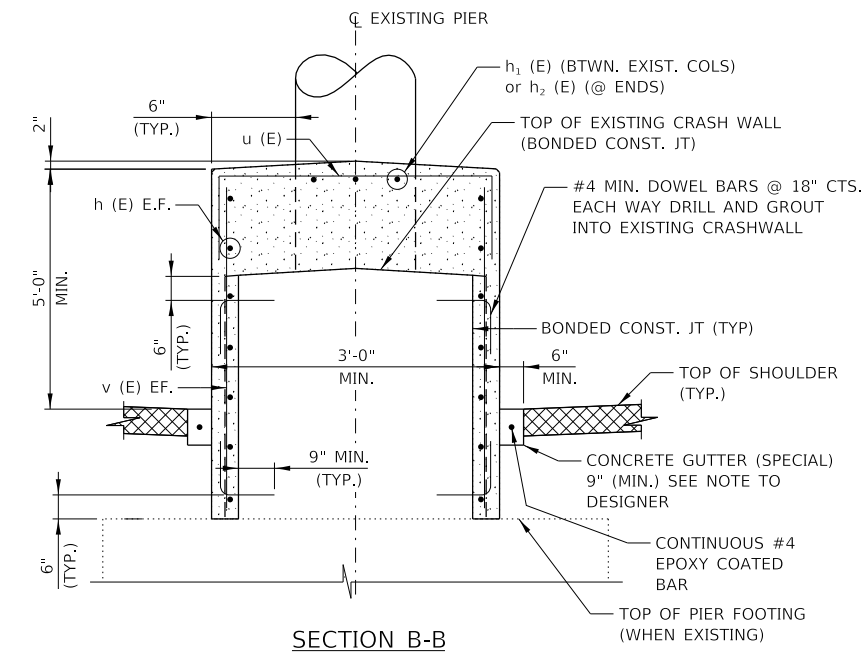

SECTION B-B

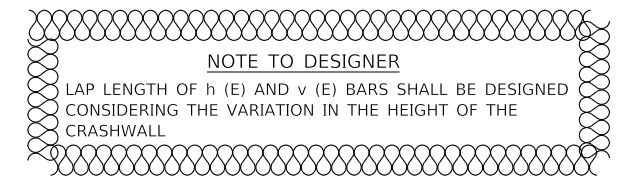

NOTE TO DESIGNER

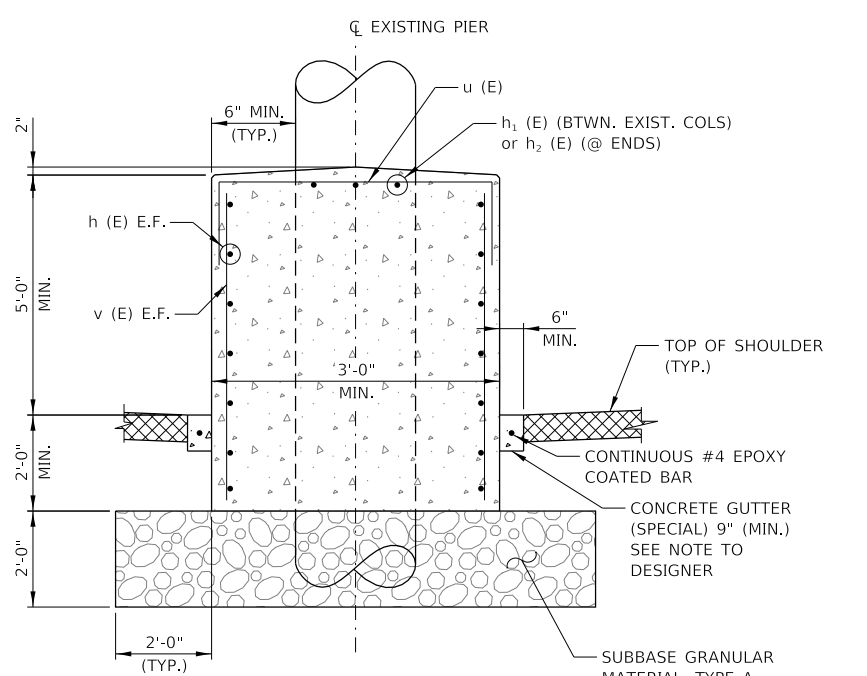

SECTION A-A

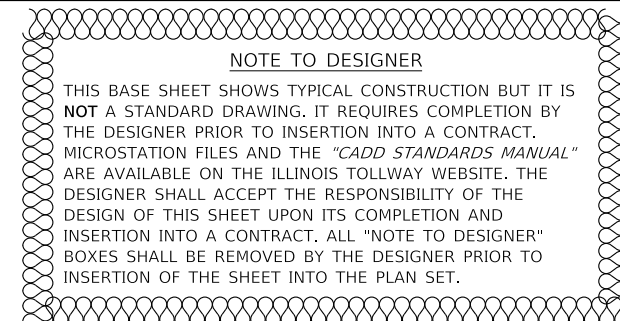

NOTE TO DESIGNER

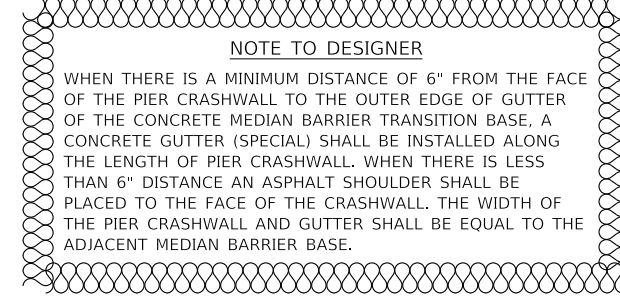

NOTE TO DESIGNER

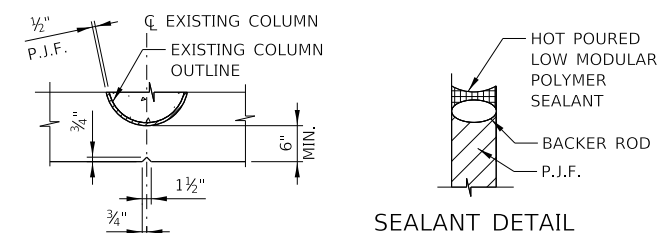

CRACK CONTROL DETAIL
REINFORCEMENT BARS OMITTED FOR CLARITY

SEALANT DETAIL

NOTES:

1. REMOVE EXISTING CONCRETE CRASHWALL BACK TO FACE OF COLUMNS PRIOR TO PLACING CONCRETE AROUND EXISTING CRASHWALL AND COLUMNS. SURFACES TO RECEIVE NEW CONCRETE SHALL BE BLAST CLEANED. COST OF CLEANING SHALL BE INCLUDED IN THE COST OF CONCRETE REMOVAL.
2. CONCRETE MEDIAN BARRIER TRANSITION TAPER LENGTHS, PAY LIMITS AND MEASUREMENT, AND BASIS OF PAYMENT ALL IN ACCORDANCE WITH THE ILLINOIS TOLLWAY STANDARD DRAWING C13, C14 AND THE SPECIAL PROVISIONS.
3. THE CLEAR COVER FOR REINFORCEMENT BARS TO THE SURFACE OF CONCRETE SHALL BE 2" UNLESS OTHERWISE SHOWN.
4. REINFORCEMENT BARS DESIGNATED "(E)" SHALL BE EPOXY COATED.
5. EXPOSED CONCRETE EDGES SHALL HAVE 3/4"x45° CHAMFERS. CHAMFERS ON VERTICAL EDGES SHALL BE CONTINUED A MINIMUM OF ONE FOOT BELOW FINISHED GROUND LEVEL.
6. CONCRETE SEALANT SHALL BE APPLIED TO THE EXPOSED SURFACES OF ALL NEW AND/OR MODIFIED PIER CRASH WALLS.
7. E.F. DENOTES EACH FACE.

LEGEND:

- P.J.F.
- NEW CONCRETE
- BITUMINOUS SHOULDER

**CRASH WALL MODIFICATIONS
MEDIAN PIERS**

VERSION: 2022-03 STANDARD: M-BRG-507 SHEET: 1 OF 1

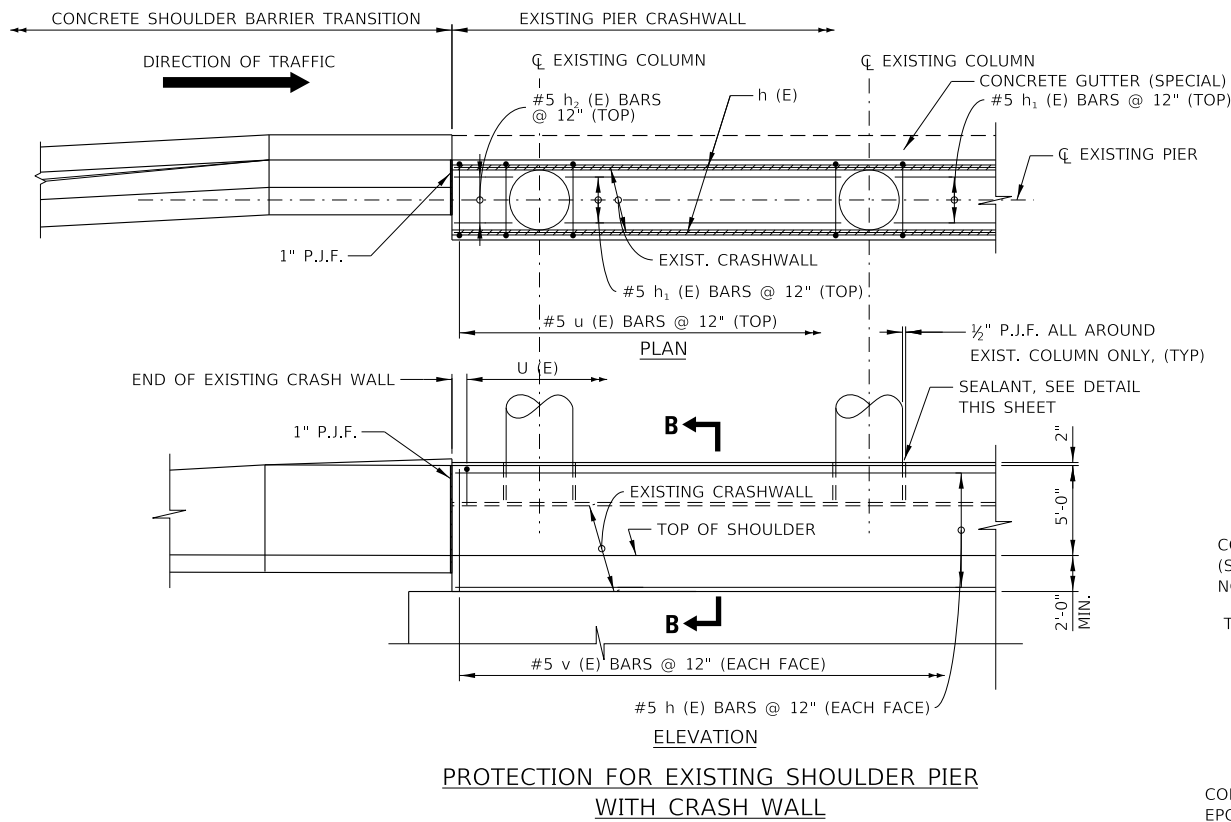

PROTECTION FOR EXISTING SHOULDER PIER WITH CRASH WALL

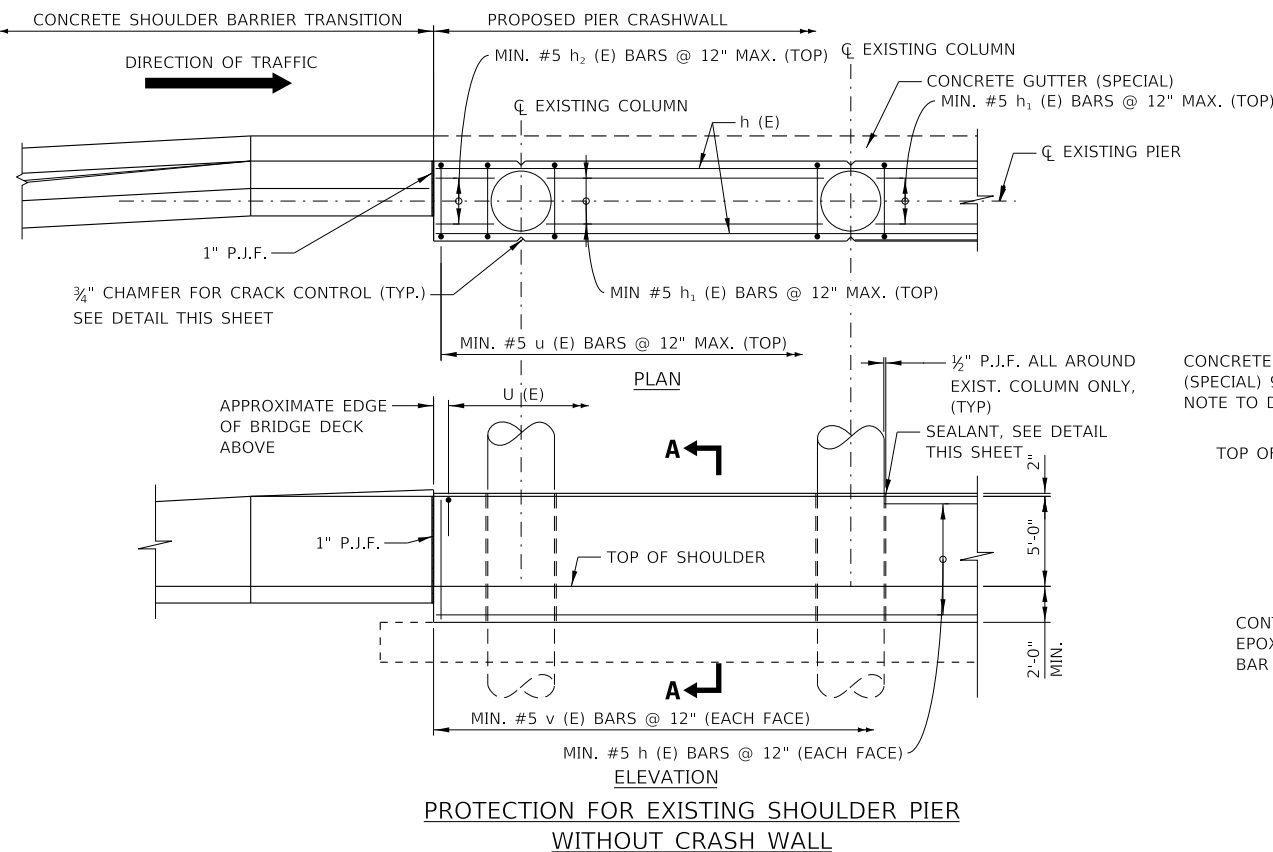

PROTECTION FOR EXISTING SHOULDER PIER WITHOUT CRASH WALL

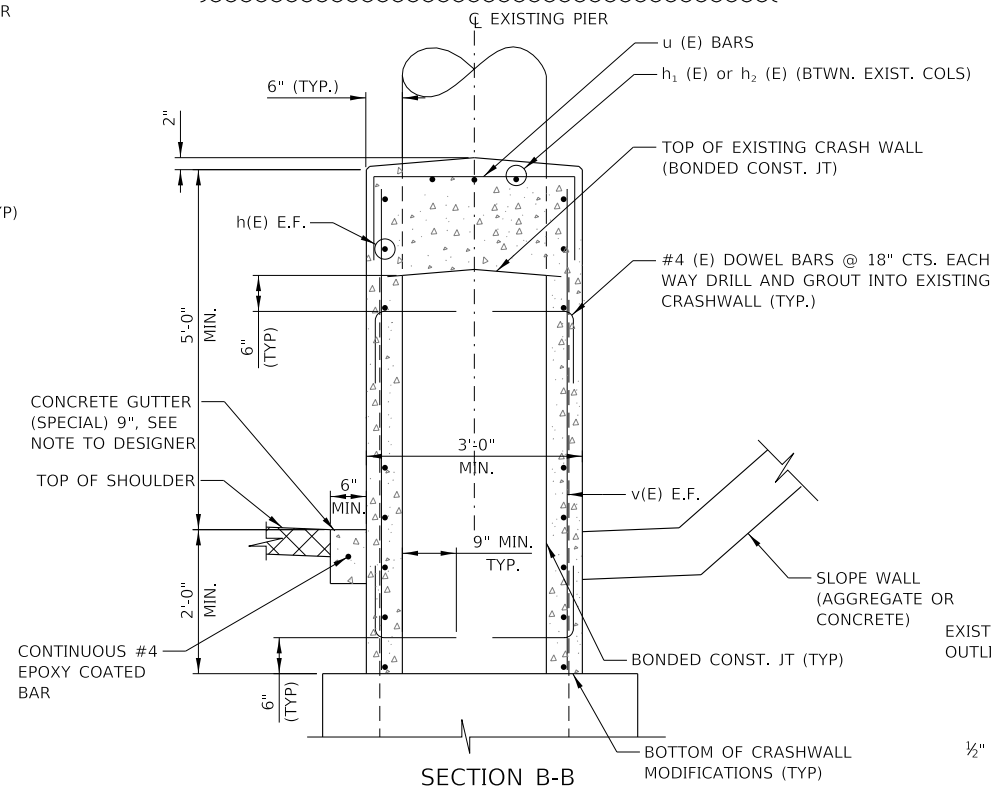
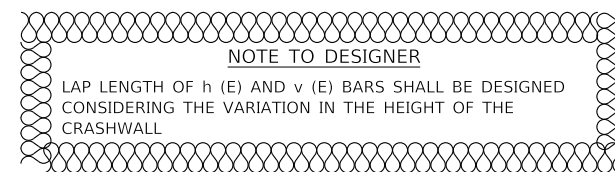

SECTION B-B

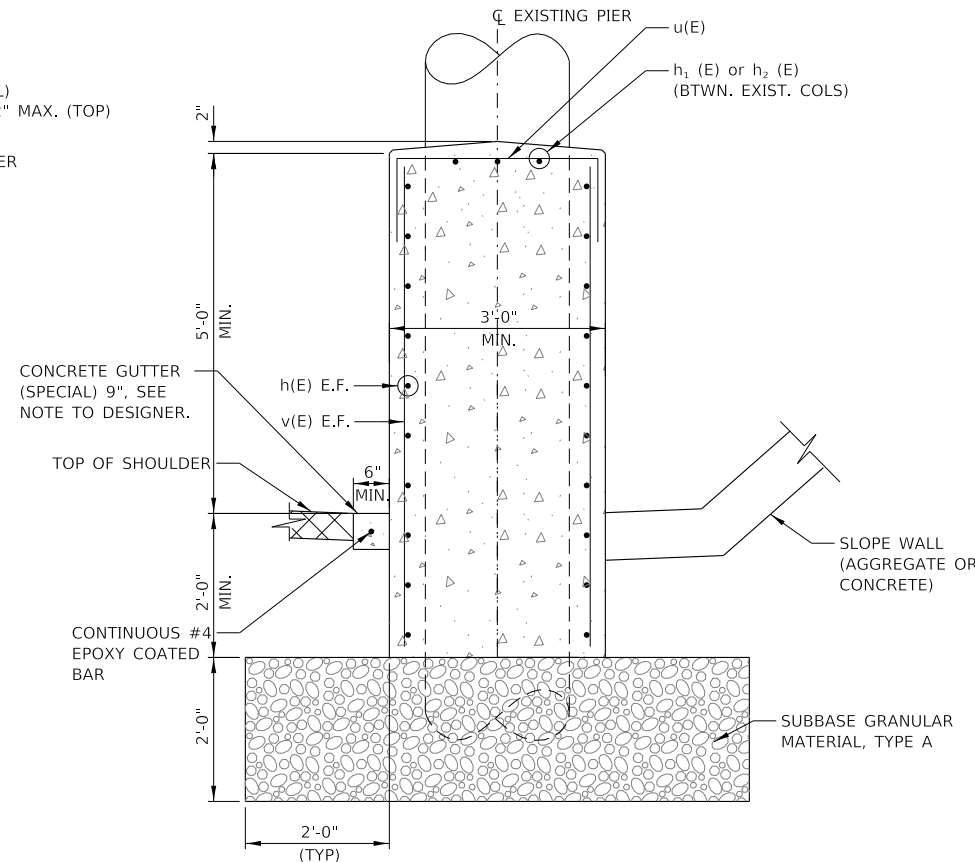

SECTION A-A

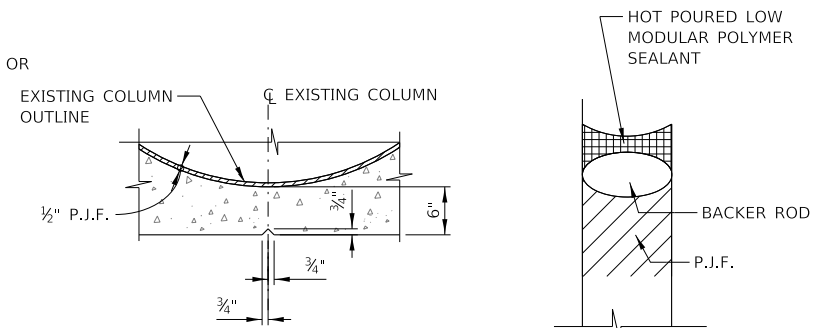
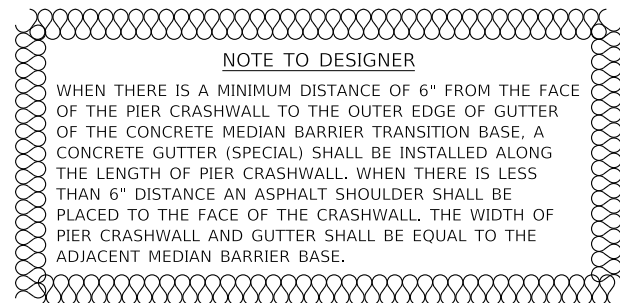
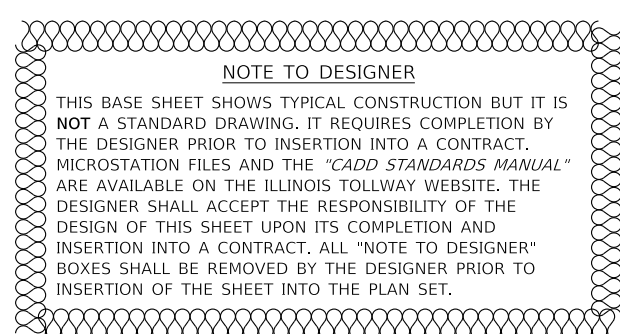

CRACK CONTROL DETAIL

SEALANT DETAIL

NOTES

1. REMOVE EXISTING CONCRETE CRASHWALL BACK TO FACE OF COLUMNS PRIOR TO PLACING CONCRETE AROUND EXISTING CRASHWALL AND COLUMNS. SURFACES TO RECEIVE NEW CONCRETE SHALL BE BLAST CLEANED. COST OF CLEANING SHALL BE INCLUDED IN THE COST OF CONCRETE REMOVAL.
2. CONCRETE SHOULDER BARRIER TRANSITION TAPER LENGTHS, PAY LIMITS AND MEASUREMENT, AND BASIS OF PAYMENT ALL IN ACCORDANCE WITH THE ILLINOIS TOLLWAY STANDARD DRAWING C7, C13, C14 AND THE SPECIAL PROVISIONS.
3. THE CLEAR COVER FOR REINFORCEMENT BARS TO THE SURFACE OF CONCRETE SHALL BE 2" UNLESS OTHERWISE SHOWN.
4. REINFORCEMENT BARS DESIGNATED "(E)" SHALL BE EPOXY COATED.
5. EXPOSED CONCRETE EDGES SHALL HAVE 3/4"x45° CHAMFERS. CHAMFERS ON VERTICAL EDGES SHALL BE CONTINUED A MINIMUM OF ONE FOOT BELOW FINISHED GROUND LEVEL.
6. CONCRETE SEALANT SHALL BE APPLIED TO THE EXPOSED SURFACES OF ALL NEW AND/OR MODIFIED PIER CRASH WALLS.
7. E.F. DENOTES EACH FACE

LEGEND:

- P.J.F.
- NEW CONCRETE
- BITUMINOUS SHOULDER

CRASH WALL MODIFICATIONS SHOULDER PIERS

VERSION: 2021-03 STANDARD: M-BRG-508 SHEET: 1 OF 1

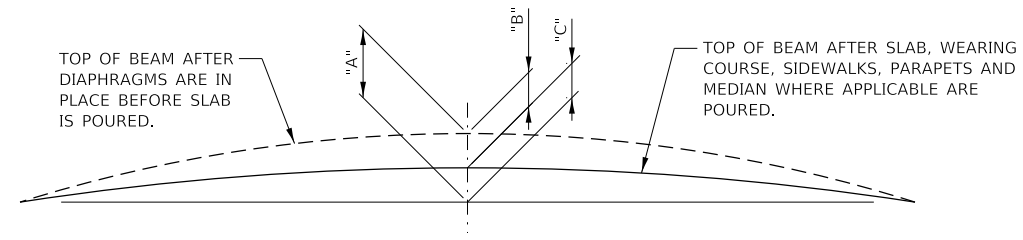
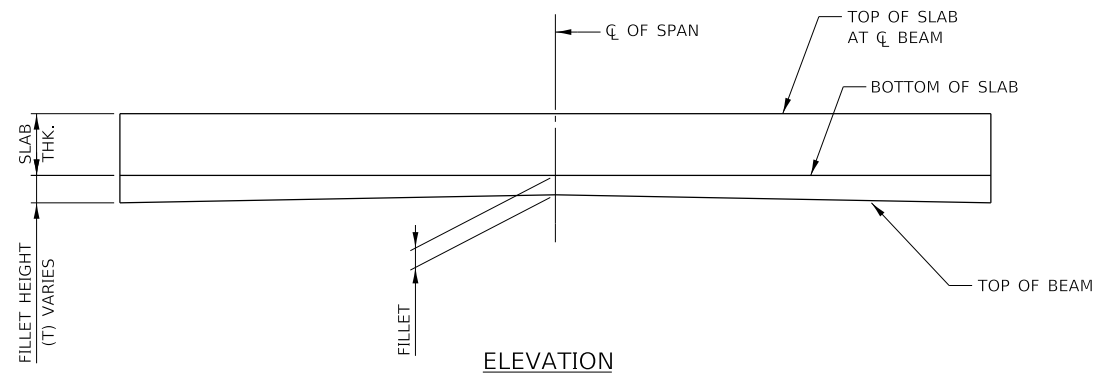

CAMBER & DEFLECTION DIAGRAM

- * "A" = PRESTRESS CAMBER
- * "B" = DEAD LOAD DEFLECTION
- * "C" = RESIDUAL CAMBER
- * ROUND OFF TO NEAREST 1/8"

CONTRACTOR SHALL TAKE ELEVATIONS AT TOP OF BEAMS AFTER ERECTION AND SHALL ALLOW FOR DEFLECTION SHOWN TO ENABLE BUILDING FORMS TO CORRECT GRADE AND SPECIFIED SLAB THICKNESS. PROVIDE COPY OF ELEVATIONS TO THE ENGINEER.

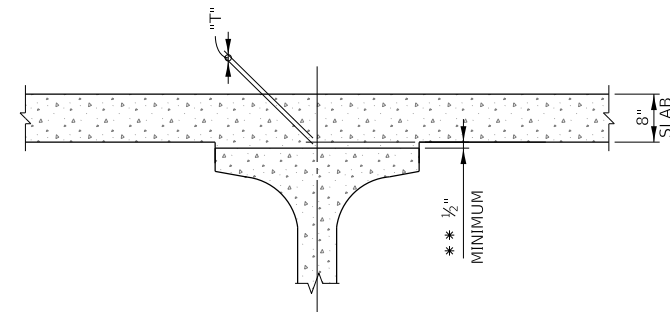

**ALL GIRDER SIZES
INTERIOR GIRDER DETAIL**

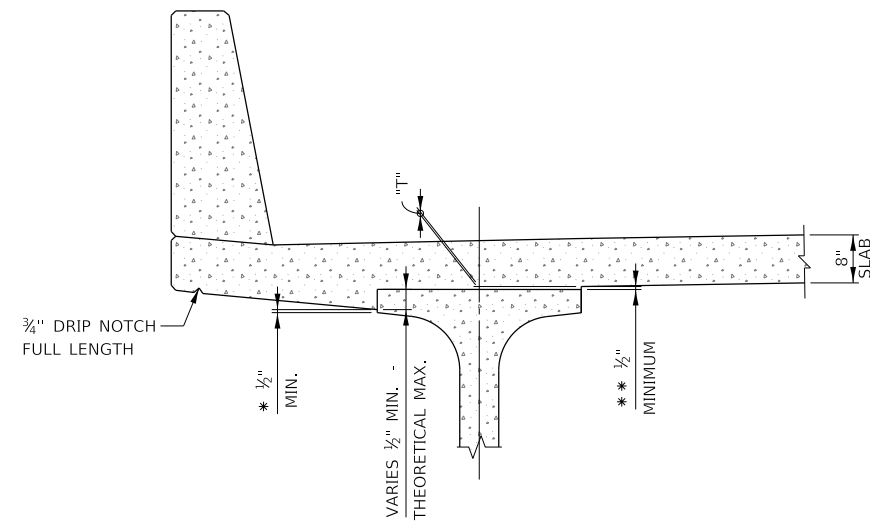

**45" OR LESS PPC BULB-T EXTERIOR BEAMS
DECK HAUNCH DETAIL**
* VARIABLE, NOT LESS THAN 1/2"

IF 1/2" MINIMUM FILLET HEIGHT AT THE EDGE OF BEAM CANNOT BE MAINTAINED, NOTIFY THE ENGINEER OF RECORD.

TO DETERMINE "T", ELEV. OF TOP OF BEAMS AT CL OF STRUCTURE UNITS & AT 1/10 POINTS OF EACH SPAN SHALL BE TAKEN. THEN FOLLOW THIS PROCESS:
 - TOP OF DECK ELEV. AT FINAL GRADE
 - TOP OF BEAM ELEVATION
 + DEAD LOAD DEFLECTION
 - SLAB THICKNESS
 = FILLET HEIGHT "T"

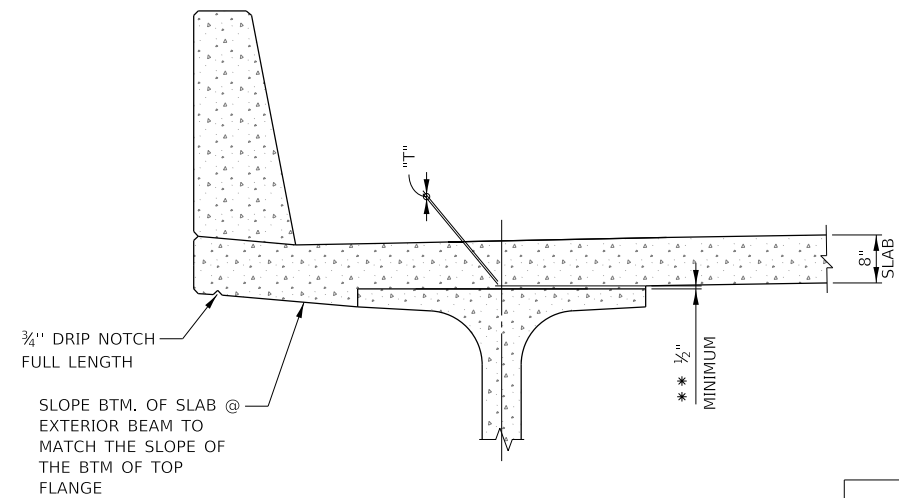

**54" OR GREATER PPC BULB-T BEAMS
SLAB HAUNCH DETAIL**

NOTE TO DESIGNER

THIS BASE SHEET SHOWS TYPICAL CONSTRUCTION BUT IT IS NOT A STANDARD DRAWING. IT REQUIRES COMPLETION BY THE DESIGNER PRIOR TO INSERTION INTO A CONTRACT. MICROSTATION FILES AND THE "CADD STANDARDS MANUAL" ARE AVAILABLE ON THE ILLINOIS TOLLWAY WEBSITE. THE DESIGNER SHALL ACCEPT THE RESPONSIBILITY OF THE DESIGN OF THIS SHEET UPON ITS COMPLETION AND INSERTION INTO A CONTRACT. ALL "NOTE TO DESIGNER" BOXES SHALL BE REMOVED BY THE DESIGNER PRIOR TO INSERTION OF THE SHEET INTO THE PLAN SET.

NOTE TO DESIGNER

1. PRESENT PRACTICE IS TO USE A MINIMUM "FILLET" (AT EDGE OF BEAM FLANGE) OF 1/2" FOR DESIGN CALCULATIONS. THE MINIMUM FILLET (AT EDGE OF BEAM FLANGE) ALLOWED IN CONSTRUCTION IS 1/2" AT MID-SPAN AND 2" AT CENTERLINE OF BEARING.
- ** 2. IF 1/2" MINIMUM FILLET HEIGHT AT EDGE OF BEAM AT MID-SPAN CANNOT BE MAINTAINED DURING CONSTRUCTION, THE GRADE LINE MAY BE RAISED BY UP TO 1/2" FROM THE PLAN PROFILE AT THE DISCRETION OF THE DESIGNER. 3" MINIMUM DECK EMBEDMENT OF THE TIE BAR SHALL BE MAINTAINED. THE PLAN SLAB THICKNESS SHALL BE HELD.
3. USE THE CALCULATED THEORETICAL AVERAGE "FILLET" AT CENTERLINE OF FLANGE FOR COMPUTING THE FILLET CONCRETE QUANTITY.
4. USE TOP OF DECK ELEVATIONS AND CALCULATED "FILLET" AT CENTERLINE OF BEAM FOR COMPUTING BEAM SEAT ELEVATIONS AT SUBSTRUCTURES.
5. FOR SKEWS < 10°, PLACE INTERMEDIATE DIAPHRAGMS IN A STRAIGHT LINE. REFER TO SHEETS M-BRG-518 PROVIDE OFFSET FOR SKEWS > 10°.
6. DIAPHRAGM SPACING: FOR SPANS < 80'-0", PLACE ONE DIAPHRAGM AT MID-LENGTH OF BEAM. FOR SPANS OVER 80'-0", PLACE AT 1/3 AND 2/3 POINTS.



PPC BEAM DETAILS

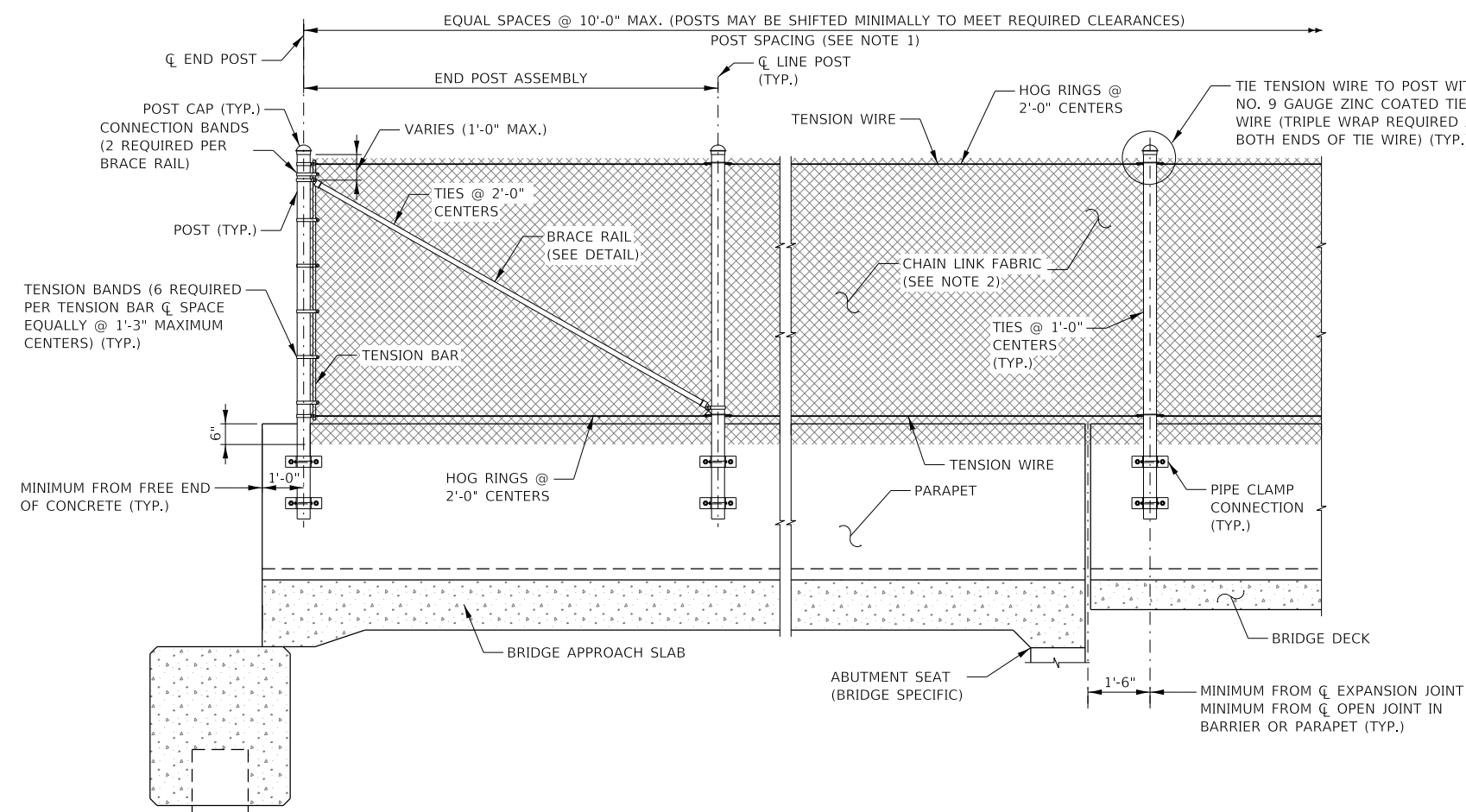

ELEVATION OF OUTSIDE FACE OF BARRIER PARAPET AND FENCE
 *FENCING SHALL NOT ANCHOR TO THE TOP OF PARAPETS

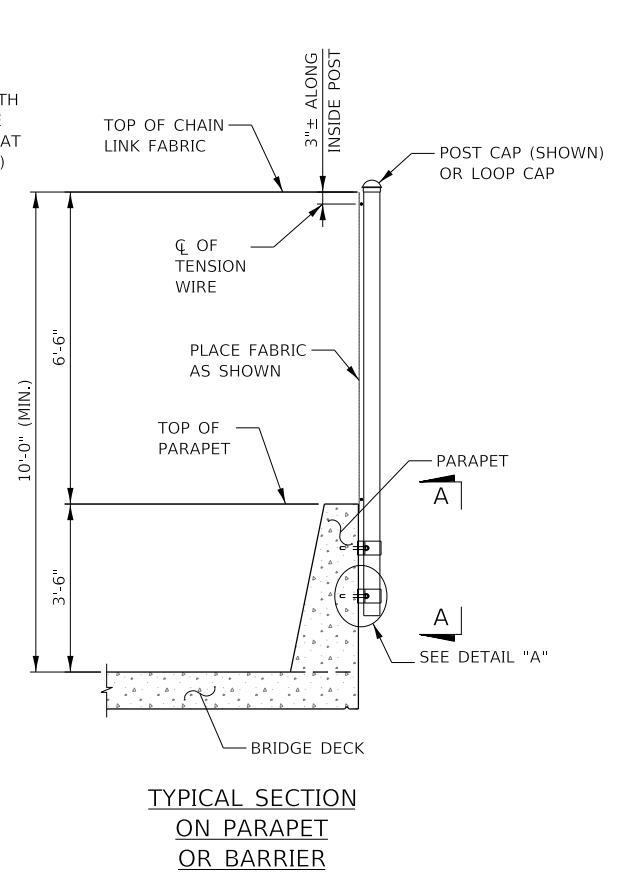

TYPICAL SECTION ON PARAPET OR BARRIER

NOTE TO DESIGNER
 THIS BASE SHEET SHOWS TYPICAL CONSTRUCTION BUT IT IS NOT A STANDARD DRAWING. IT REQUIRES COMPLETION BY THE DESIGNER PRIOR TO INSERTION INTO A CONTRACT. MICROSTATION FILES AND THE "CADD STANDARDS MANUAL" ARE AVAILABLE ON THE ILLINOIS TOLLWAY WEBSITE. THE DESIGNER SHALL ACCEPT THE RESPONSIBILITY OF THE DESIGN OF THIS SHEET UPON ITS COMPLETION AND INSERTION INTO A CONTRACT. ALL "NOTE TO DESIGNER" BOXES SHALL BE REMOVED BY THE DESIGNER PRIOR TO INSERTION OF THE SHEET INTO THE PLAN SET.

- DESIGNER NOTES:**
- PULL POST ASSEMBLY IS REQUIRED AT MAXIMUM INTERVALS OF 200'. SEE SHEET 2 OF THIS SERIES.
 - INSTALL POSTS PLUMB (WITHIN A TOLERANCE OF $\pm 1\frac{1}{2}$ ". USE SHIM PLATES AS REQUIRED TO ACHIEVE PLUMB. INSTALL CHAIN LINK FENCE IN ACCORDANCE WITH ASTM F5678 AS APPLICABLE.
 - FABRIC SHALL NOT BE SPLICED BY PICKETS. FABRIC SPLICES IF REQUIRED SHALL ONLY OCCUR AT POSTS AT A MINIMUM OF 100 FT. BETWEEN SPLICES. (ADD THIS NOTE TO PLANS.)
 - RAILROAD BRIDGE FENCE SHALL BE DETAILED ON SUPERSTRUCTURE DRAWING.
 - COORDINATE LIMITS OF RAILROAD BRIDGE FENCE WITH SPECIFIC RAILROAD REQUIREMENTS.
 - VERIFY LIMITS OF THE FENCING REQUIREMENTS ON THE BRIDGE APPROACH PER THE ILLINOIS TOLLWAY STRUCTURAL DESIGN MANUAL ARTICLE 23.5.2.

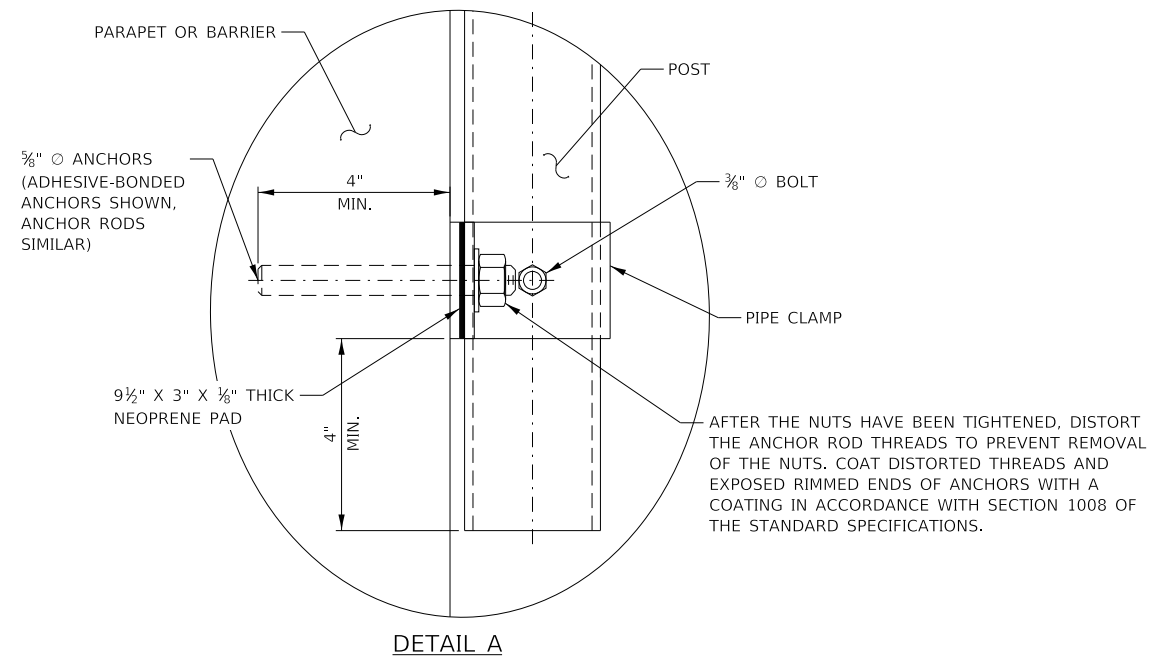
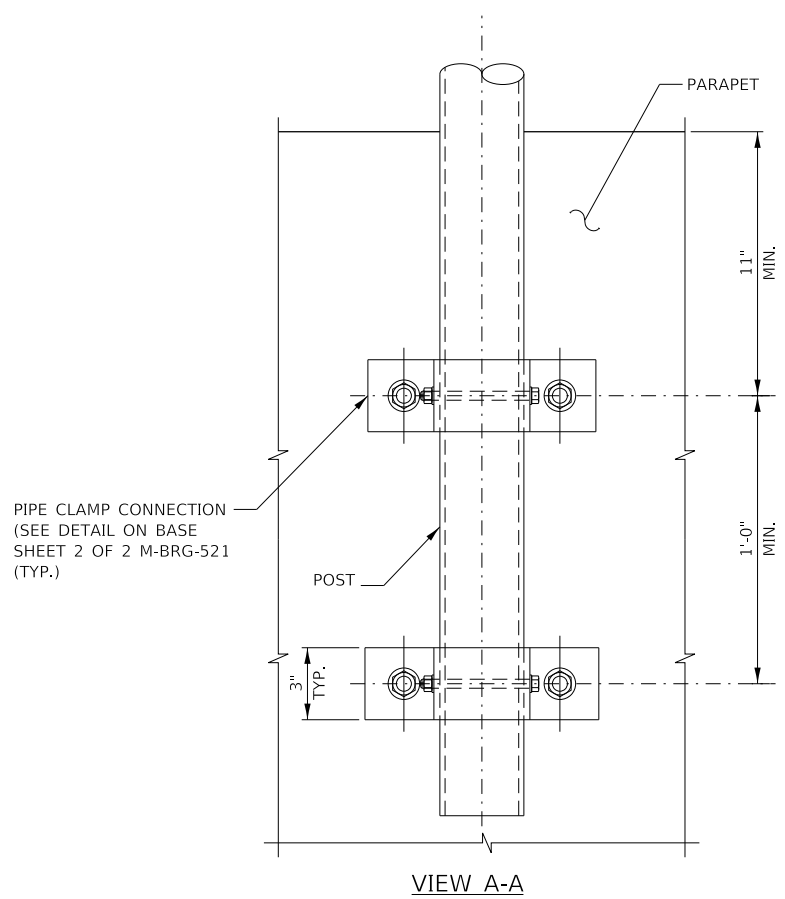
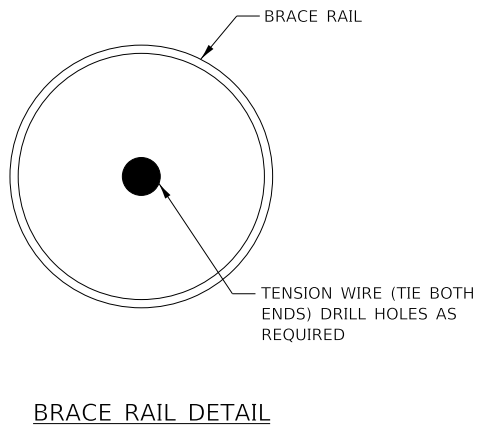

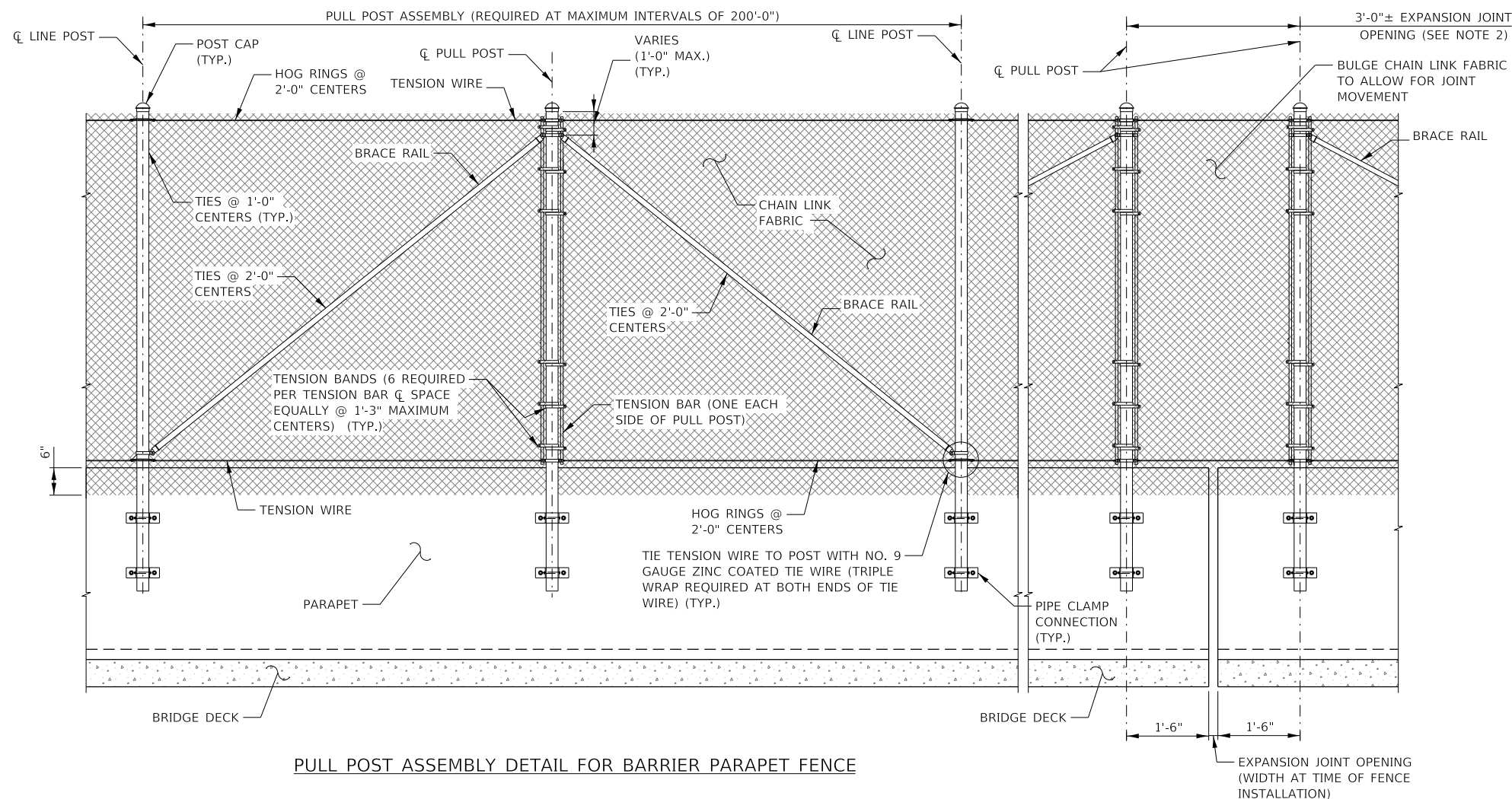

PULL POST ASSEMBLY DETAIL FOR BARRIER PARAPET FENCE

EXPANSION ASSEMBLY DETAIL
(REQUIRED ONLY AT EXPANSION JOINT LOCATIONS WHERE TOTAL MOVEMENT EXCEEDS 6")

NOTE TO DESIGNER

THIS BASE SHEET SHOWS TYPICAL CONSTRUCTION BUT IT IS NOT A STANDARD DRAWING. IT REQUIRES COMPLETION BY THE DESIGNER PRIOR TO INSERTION INTO A CONTRACT. MICROSTATION FILES AND THE "CADD STANDARDS MANUAL" ARE AVAILABLE ON THE ILLINOIS TOLLWAY WEBSITE. THE DESIGNER SHALL ACCEPT THE RESPONSIBILITY OF THE DESIGN OF THIS SHEET UPON ITS COMPLETION AND INSERTION INTO A CONTRACT. ALL "NOTE TO DESIGNER" BOXES SHALL BE REMOVED BY THE DESIGNER PRIOR TO INSERTION OF THE SHEET INTO THE PLAN SET.

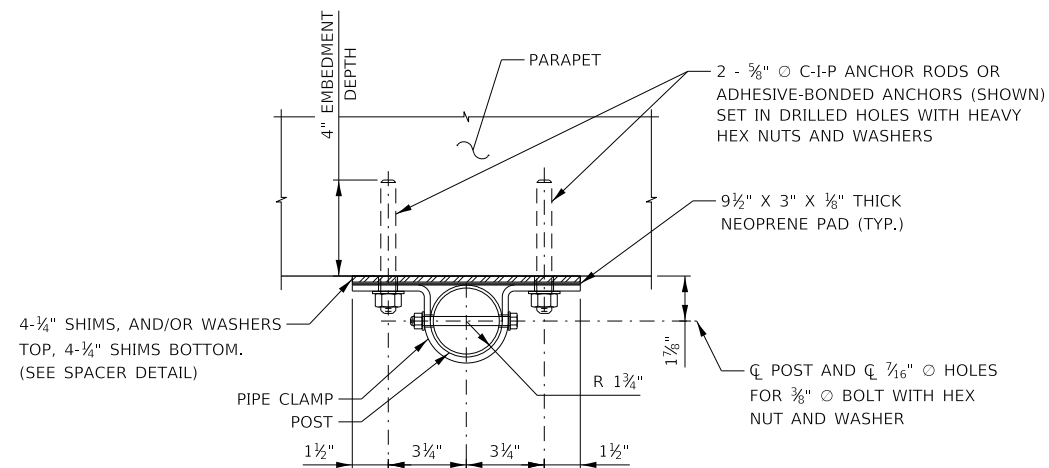

PIPE CLAMP CONNECTION DETAIL

- NOTES:**
1. FOR TREATMENT AT BRIDGE ENDS, SEE BASE SHEET 1 OF 2 M-BRG-521.
 2. THE 3'-0" DIMENSION SHOWN IS FOR EXPANSION JOINT OPENINGS 9" OR LESS. IF THE EXPANSION JOINT OPENING EXCEEDS 9", INCREASE THIS DIMENSION BY THE DIFFERENCE BETWEEN THE EXPANSION JOINT OPENING AND 9".

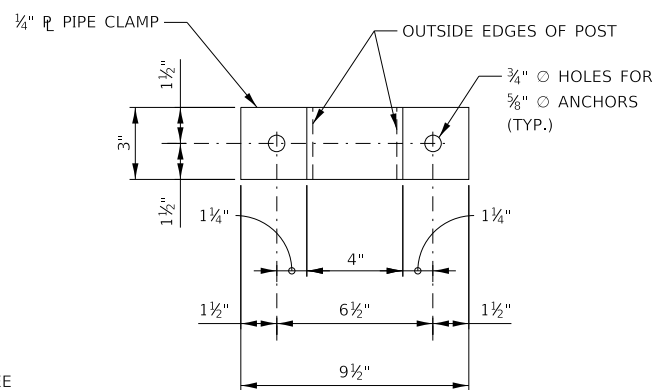

PIPE CLAMP DETAIL

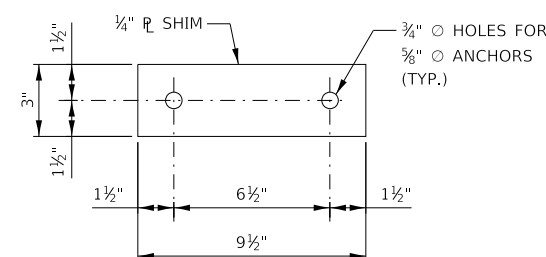

SPACER DETAIL
(MUST BE MANUFACTURED FROM AN INCOMPRESSIBLE MATERIAL (I.E., STEEL OR ALUMINUM))



RAILROAD BRIDGE FENCE

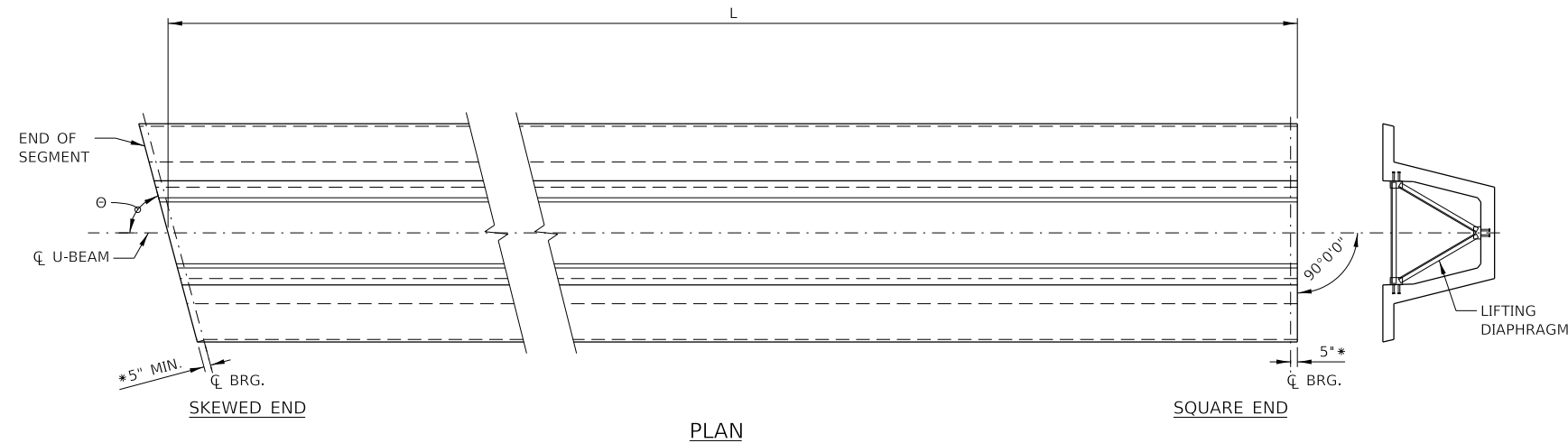

PLAN

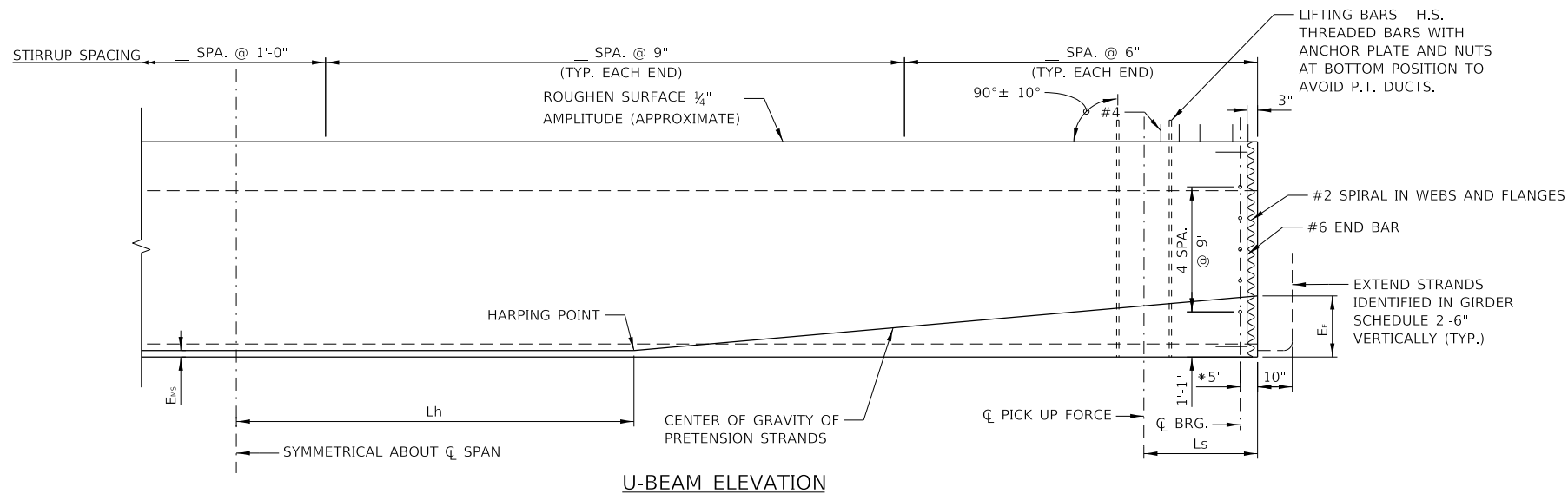

U-BEAM ELEVATION

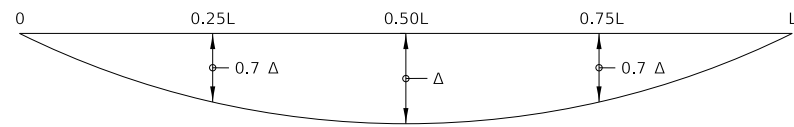

DEAD LOAD DEFLECTION DIAGRAM

SHIPPING & HANDLING DETAILS		
Ls	kg MIN. SHIPPING SUPPORT ROTATIONAL SPRING CONSTANT	wcc MIN. SHIPPING SUPPORT CL TO CL WHEEL SPACING

U-BEAM SCHEDULE																							
SPAN NO.	GIRDER NO.	L (Ft)	Fw (In.)	D (In.)	theta (Deg.)	Tw (In.)	Tb (In.)	Lh (Ft)	As* (In. ²)	DEBOND STRANDS (PERCENT)	Ee (In.)	Ems (In.)	Fj (kips)	Fi (kips)	CONCRETE STRENGTH		Delta (In.) @ 40 DAYS & @ 120 DAYS	PREDICTED CAMBER (in.)	STRANDS TO EXTEND				
															fc (psi) @ RELEASE	fc (psi) @ 28 DAYS			END 1	END 2			

NOTES:

TOP OF BEAM TO BE ROUGH FLOATED AND BROOMED TRANSVERSELY, EXCEPT THE OUTSIDE 8" OF BEAM, WHICH SHALL RECEIVE A SMOOTH FINISH. AN APPROVED CONCRETE SEALER SHALL BE APPLIED TO ALL SMOOTH SURFACES INCLUDING THE OUTSIDE 8" OF THE TOP FLANGE.

DO NOT APPLY CONCRETE SEALER TO SURFACES RECEIVING APPLICATION OF CONCRETE STAINING.

THE BEAM SHALL BE PROVIDED WITH A SUITABLE LIFTING DEVICE FOR HANDLING AND ERECTING THE BEAMS.

LIFTING EMBEDMENTS SHALL BE INSTALLED IN ACCORDANCE WITH SECTION 504 OF STANDARD SPECIFICATION FOR ROAD AND BRIDGE CONSTRUCTION. CONTRACTOR TO DESIGN OTHER LIFTING MECHANISM IF THE GIRDER SECTION WEIGHT EXCEEDS 200 KIPS.

STRANDS SHALL BE FLUSH WITH END OF BEAM. FOR BEAM ENDS EMBEDDED COMPLETELY IN CONCRETE, END OF STRANDS SHALL BE COATED WITH NON-BITUMINOUS JOINT SEALER. FOR BEAM ENDS THAT ARE FINALLY EXPOSED, COAT THE BEAM ENDS, EXPOSED STRAND ENDS AND ALL NON-BONDING SURFACES WITHIN 2 FEET OF THE BEAM ENDS WITH A NON-PIGMENTED EPOXY CONFORMING TO AASHTO M-235 TYPE III, GRADE 2, CLASS B OR C. THE EPOXY SHALL BE APPLIED AT LEAST 3 DAYS AFTER MOIST CURING HAS CEASED AND PRIOR TO THE APPLICATION OF THE SEALER.

ALL U-BEAMS SHALL BE CAST FULL LENGTH AS SHOWN.

SPACING SHOWN FOR #4 STIRRUPS IS FOR GRADE 60 REINFORCEMENT. IF THE FABRICATOR CHOOSES TO BUILD A BAR STEEL CAGE BY WELDING LONGITUDINAL REINFORCEMENT TO THE #4 STIRRUPS, ONE OPTION IS AVAILABLE:

USE ASTM A706, GRADE 60 REINFORCEMENT AND THE STIRRUP SPACING AS SHOWN ON THE PLANS.

PRESTRESSING STRANDS SHALL BE 0.6" DIA., 7-WIRE LOW, RELAXATION FOR ALL PATTERNS WITH AN ULTIMATE STRENGTH OF 270,000 psi. THE MAX NUMBER OF DRAPED 0.6" DIA STRANDS IS 8.

- A_s* = MINIMUM AREA OF THE PRESTRESSING STEEL.
- d_s = NOMINAL STRAND DIAMETER.
- f_s = ULTIMATE STRENGTH OF THE PRESTRESSING STEEL.
- F_j = JACKING FORCE PER U-BEAM.
- F_i = FINAL FORCE PER U-BEAM AFTER ALL LOSSES.
- f_{ci} = REQUIRED CONCRETE STRENGTH AT RELEASE OF PRESTRESS FORCE.
- f_c = REQUIRED CONCRETE STRENGTH AT 28 DAYS OF AGE.
- L = LENGTH OF U-BEAM ALONG THE GRADE OF THE U-BEAM.
- Delta = DEFLECTION AT CENTERLINE OF SPAN DUE TO CAST-IN-PLACE SLAB, SIDEWALK AND PARAPETS.
- P = PROJECTION. 6" IN THE MIDDLE 1/3 OF THE MEMBER VARYING TO THE SPECIFIED HAUNCH AT THE BEARING PLUS 4".
- theta = BRIDGE SKEW ANGLE

PREDICTED CAMBER IS THE CAMBER FOR THE GIRDER ALONE AT ___ DAYS.

CAUTION SHALL BE EXERCISED IN HANDLING AND PLACING GIRDERS. ALL GIRDERS SHALL BE CHECKED BY CONTRACTOR TO INSURE THEY ARE BRACED ADEQUATELY TO PREVENT TIPPING AND TO CONTROL LATERAL BENDING DURING SHIPPING ONCE ERECTED. ALL GIRDERS SHALL BE BRACED LATERALLY TO PREVENT TIPPING UNTIL ALL DIAPHRAGMS ARE CAST AND CURED.

NOTE TO DESIGNER

SPECIFY CONCRETE STRENGTH AS REQUIRED BY DESIGN FROM A MINIMUM OF 6,000 PSI TO A MAX. OF 8,500 PSI.

REINFORCEMENT IN STANDARD END SECTION OF THE BEAM IS BASED ON THE STRAND PATTERNS LISTED ON SHEET 2 OF 2 M-BRG-522. USING DIFFERENT STRAND PATTERNS WILL REQUIRE A COMPLETE DESIGN OF THIS REINFORCEMENT. PRIOR APPROVAL FROM THE ILLINOIS TOLLWAY IS REQUIRED IF DESIGN OF THE END REINFORCEMENT IS REQUIRED.

THE DESIGN ENGINEER DETERMINES THE PROJECTION OF BAR G1 BASED ON 2" MIN. HAUNCH AT EDGE OF BEAM, X-SLOPE, PROFILE GRADE LINE AND CALCULATED RESIDUAL BEAM CAMBER, INCLUDING THE CAMBER MULTIPLIER OF 1.8 FOR I-BEAMS, 1.4 FOR TUB GIRDERS. THIS VALUE CAN VARY AND SHOULD BE GIVEN FOR EACH OF THE BEAM LENGTH. PROVIDE VALUES THAT MAINTAIN 3" MIN. DECK EMBEDMENT AND 2" CLEAR FROM TOP OF DECK WHILE ACCOUNTING FOR +/- 3/4" VARIANCE IN ACTUAL CAMBER VERSUS THE CALCULATED RESIDUAL CAMBER.

DIMENSIONS NOTED WITH (*) ARE A FUNCTION OF THE DESIGN REQUIREMENTS AND MAY VARY. DIMENSION IN THE GIRDER SCHEDULE SHALL BE SHOWN TO THE NEAREST 1/8".

NOTE TO DESIGNER

THIS BASE SHEET SHOWS TYPICAL CONSTRUCTION BUT IT IS NOT A STANDARD DRAWING. IT REQUIRES COMPLETION BY THE DESIGNER PRIOR TO INSERTION INTO A CONTRACT. MICROSTATION FILES AND THE "CADD STANDARDS MANUAL" ARE AVAILABLE ON THE ILLINOIS TOLLWAY WEBSITE. THE DESIGNER SHALL ACCEPT THE RESPONSIBILITY OF THE DESIGN OF THIS SHEET UPON ITS COMPLETION AND INSERTION INTO A CONTRACT. ALL "NOTE TO DESIGNER" BOXES SHALL BE REMOVED BY THE DESIGNER PRIOR TO INSERTION OF THE SHEET INTO THE PLAN SET.



PPC U-BEAM PRETENSIONED

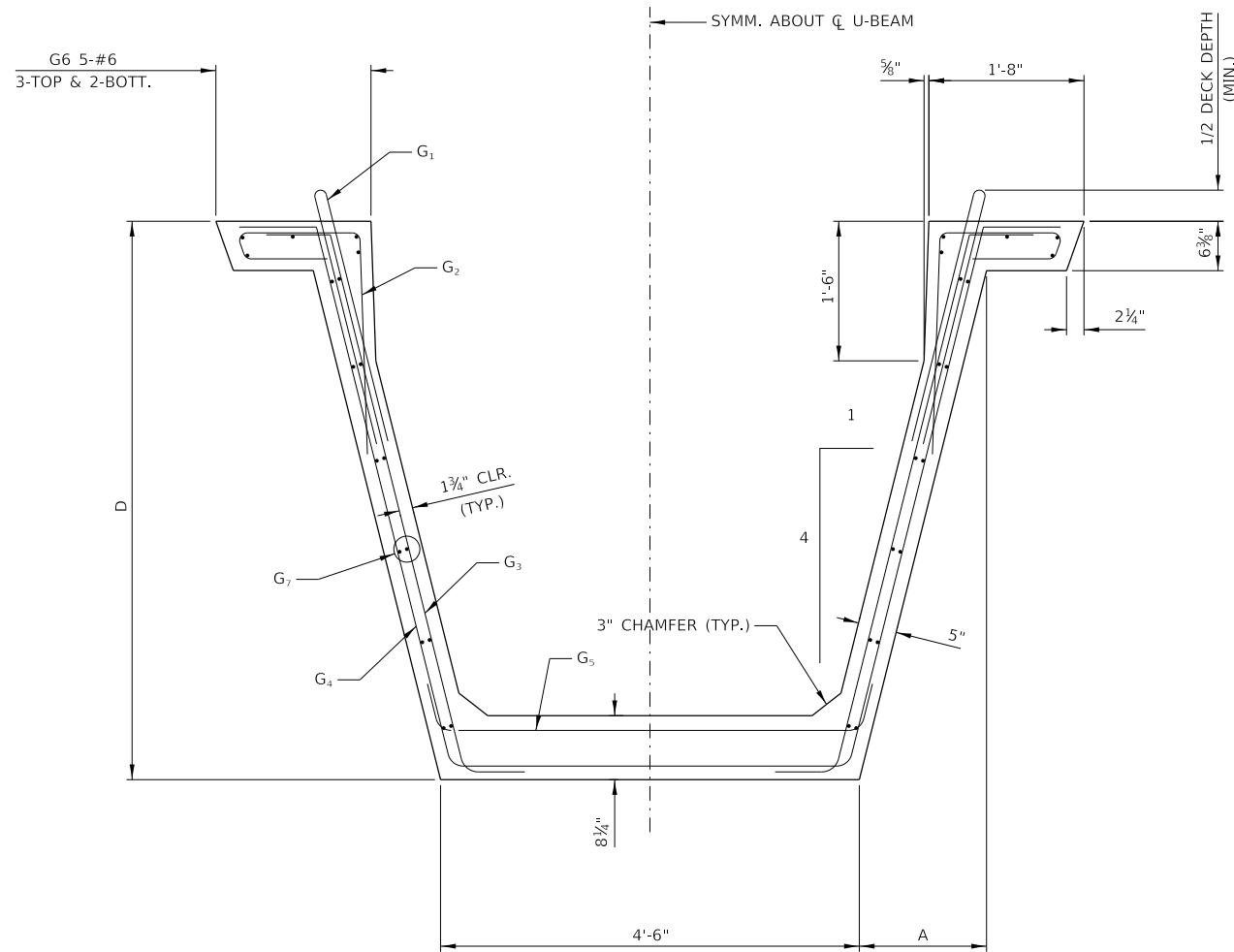

TYPICAL U-BEAM SECTION
(REINFORCEMENT SHOWN AT SPAN)

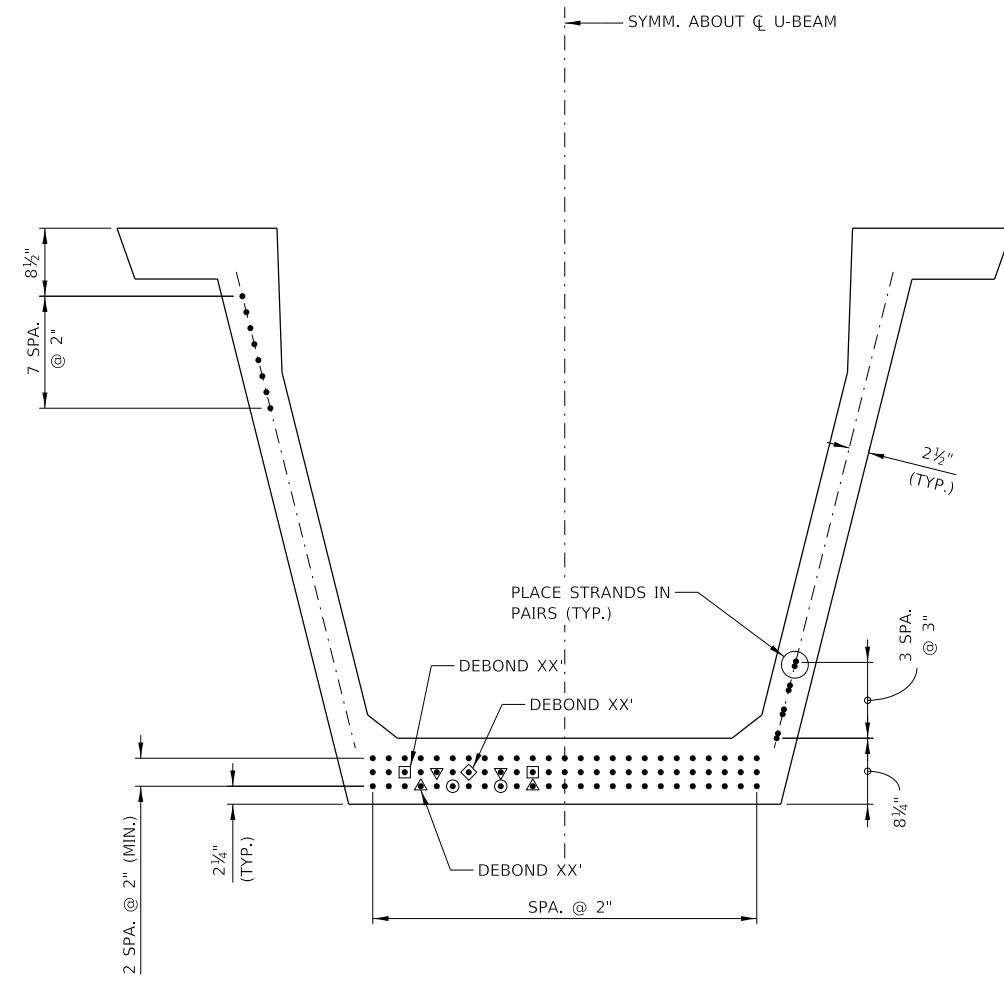

TYPICAL U-BEAM PRESTRESSING
(PRETENSIONING)

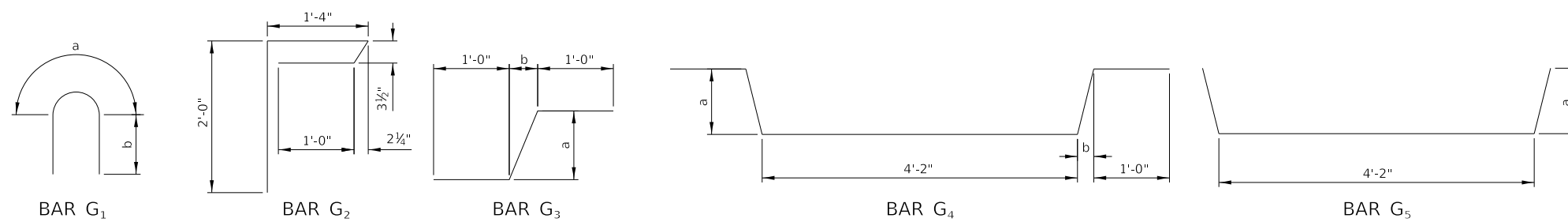

BAR G₁

BAR G₂

BAR G₃

BAR G₄

BAR G₅

BAR LIST

BAR	NO.	SIZE	LENGTH	SHAPE
G ₁	0	#4	X'-X"	
G ₂				
G ₃				
G ₄				
G ₅				
G ₆	10	#6		
G ₇				
G ₈		#6		

VARIABLE DIMENSIONS

BAR	a	b
G ₁		
G ₂		
G ₃		
G ₄		
G ₅		

BEAM TABLE

D	A
48"	10 3/8"
60"	1'-1 3/8"
72"	1'-4 3/8"

NOTE TO DESIGNER

THIS BASE SHEET SHOWS TYPICAL CONSTRUCTION BUT IT IS NOT A STANDARD DRAWING. IT REQUIRES COMPLETION BY THE DESIGNER PRIOR TO INSERTION INTO A CONTRACT. MICROSTATION FILES AND THE "CADD STANDARDS MANUAL" ARE AVAILABLE ON THE ILLINOIS TOLLWAY WEBSITE. THE DESIGNER SHALL ACCEPT THE RESPONSIBILITY OF THE DESIGN OF THIS SHEET UPON ITS COMPLETION AND INSERTION INTO A CONTRACT. ALL "NOTE TO DESIGNER" BOXES SHALL BE REMOVED BY THE DESIGNER PRIOR TO INSERTION OF THE SHEET INTO THE PLAN SET.



PPC U-BEAM PRETENSIONED

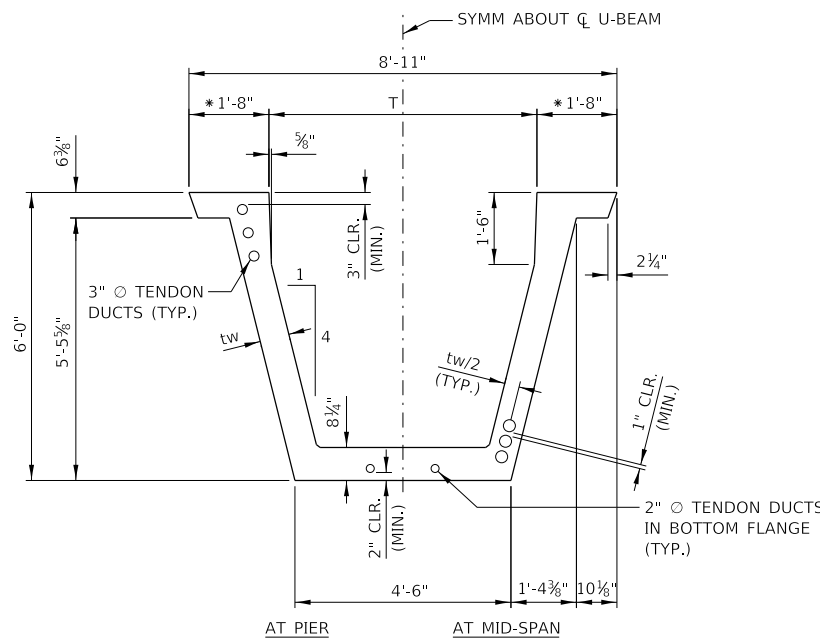

72" U-BEAM (DIMENSIONS)

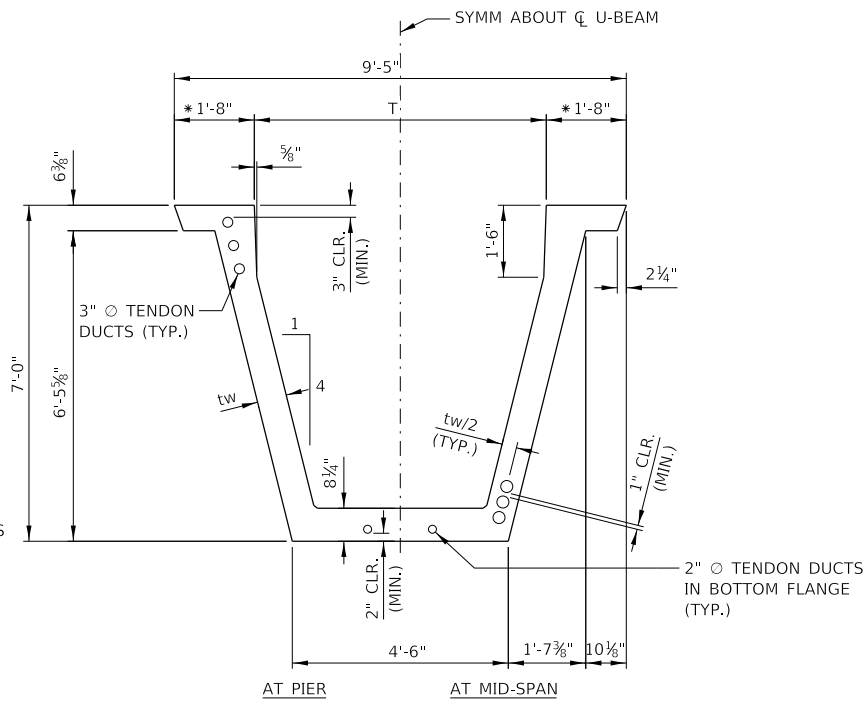

84" U-BEAM (DIMENSIONS)

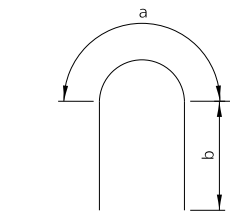

BAR G₁

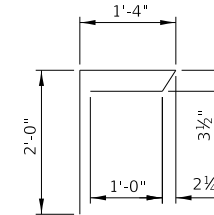

BAR G₂

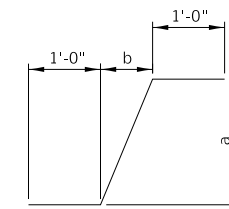

BAR G₃

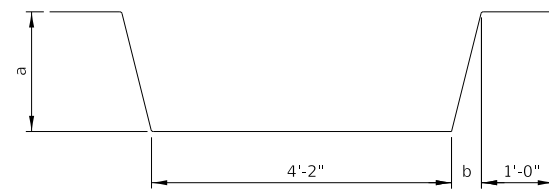

BAR G₄

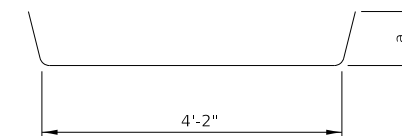

BAR G₅

VARIABLE DIMENSIONS

BAR	NO.	SIZE	LENGTH	SHAPE
G ₁	0	#4	X'-X"	
G ₂				
G ₃				
G ₄				
G ₅				
G ₆		#6		
G ₇				

BAR	a	b
G ₁		
G ₂		
G ₃		
G ₄		
G ₅		
G ₆		
G ₇		

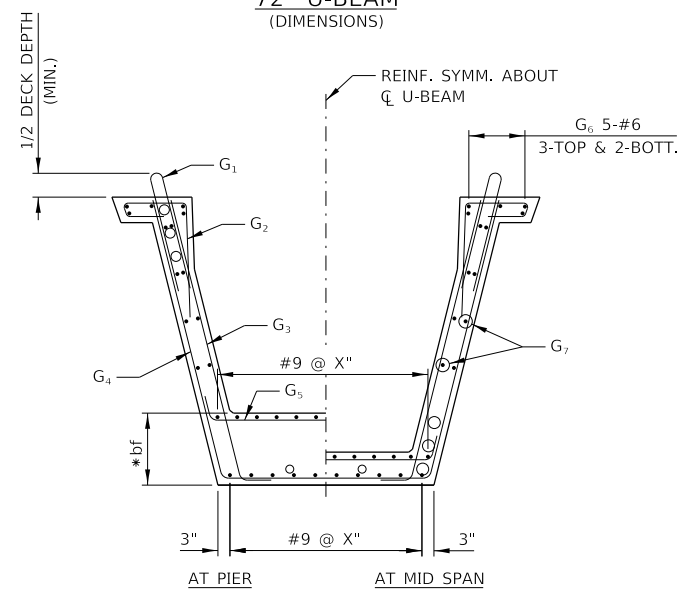

72" U-BEAM (REINFORCEMENT)

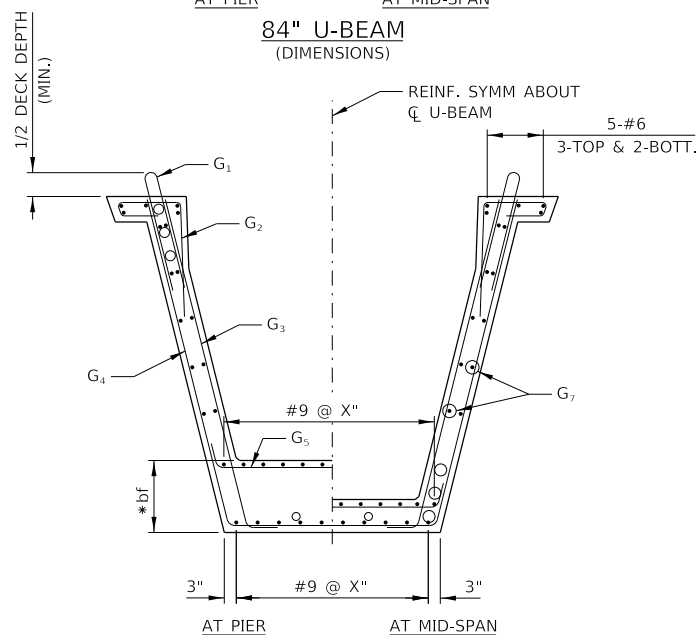

84" U-BEAM (REINFORCEMENT)

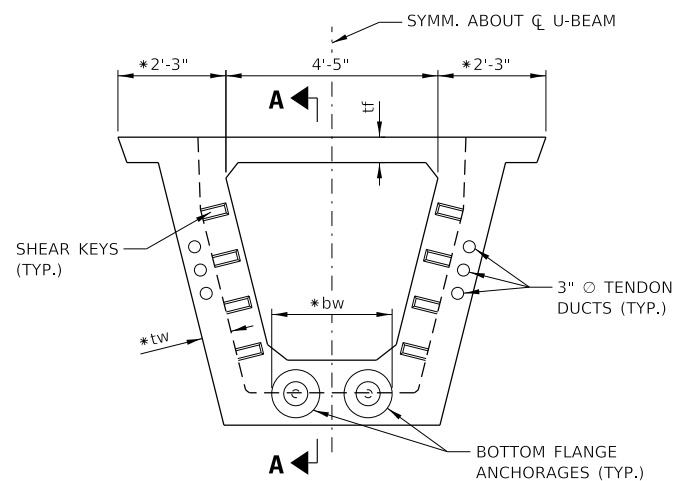

72" U-BEAM (END SECTION)

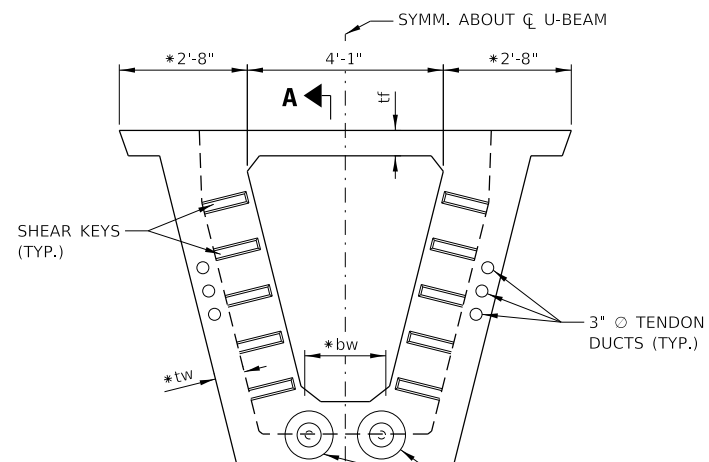

84" U-BEAM (END SECTION)

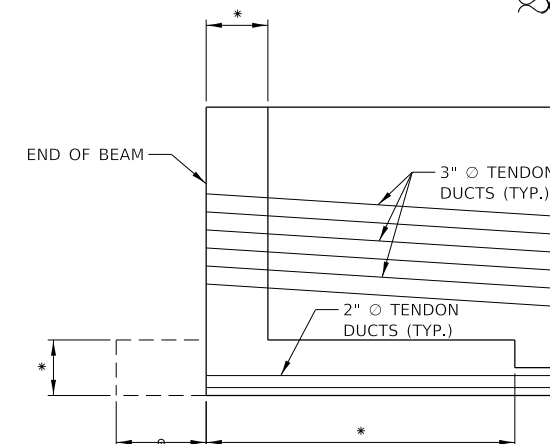

SECTION A-A (END SECTION)

NOTE TO DESIGNER

THIS BASE SHEET SHOWS TYPICAL CONSTRUCTION BUT IT IS NOT A STANDARD DRAWING. IT REQUIRES COMPLETION BY THE DESIGNER PRIOR TO INSERTION INTO A CONTRACT. MICROSTATION FILES AND THE "CADD STANDARDS MANUAL" ARE AVAILABLE ON THE ILLINOIS TOLLWAY WEBSITE. THE DESIGNER SHALL ACCEPT THE RESPONSIBILITY OF THE DESIGN OF THIS SHEET UPON ITS COMPLETION AND INSERTION INTO A CONTRACT. ALL "NOTE TO DESIGNER" BOXES SHALL BE REMOVED BY THE DESIGNER PRIOR TO INSERTION OF THE SHEET INTO THE PLAN SET.

NOTE TO DESIGNER

DIMENSIONS NOTED WITH (*) ARE A FUNCTION OF THE DESIGN REQUIREMENTS AND MAY VARY.



72IN. AND 84IN. PPC U-BEAM POST-TENSIONED

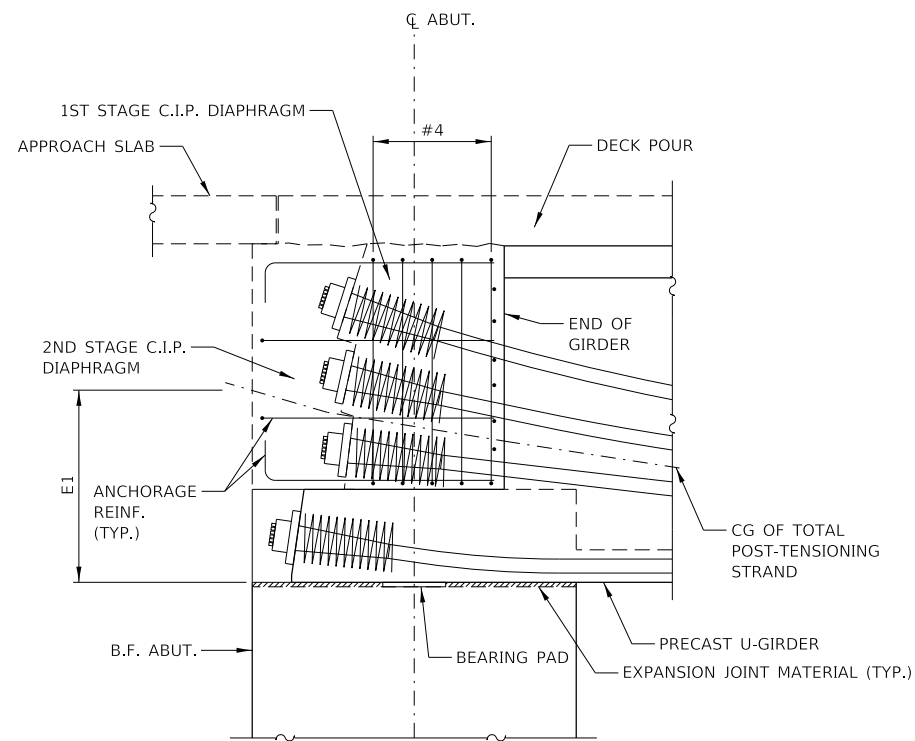

INTEGRAL ABUTMENT

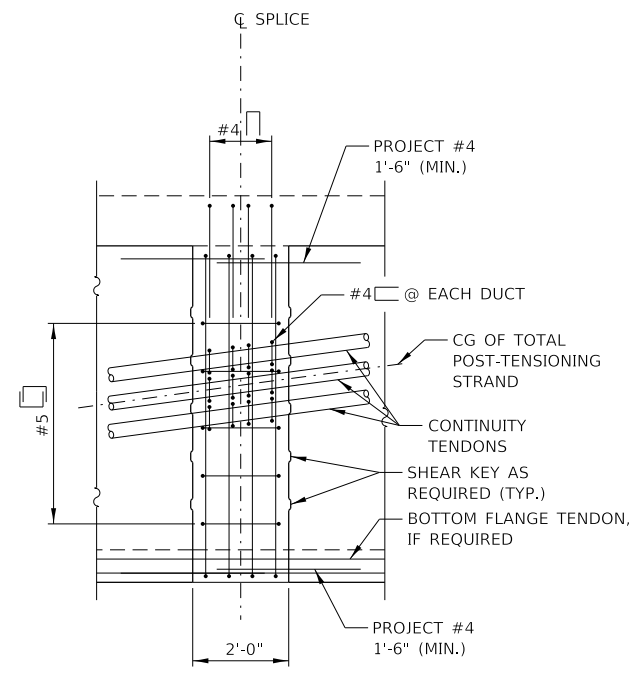

SPLICE DETAIL

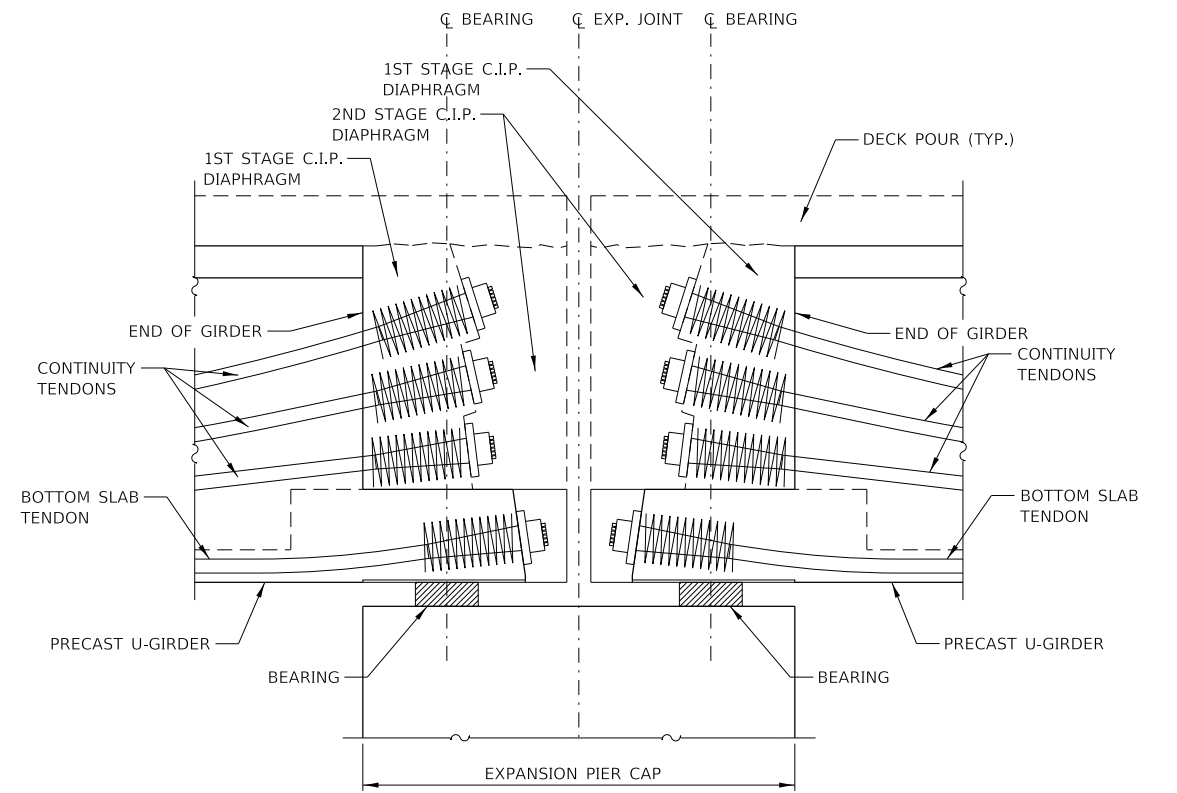

EXPANSION PIER

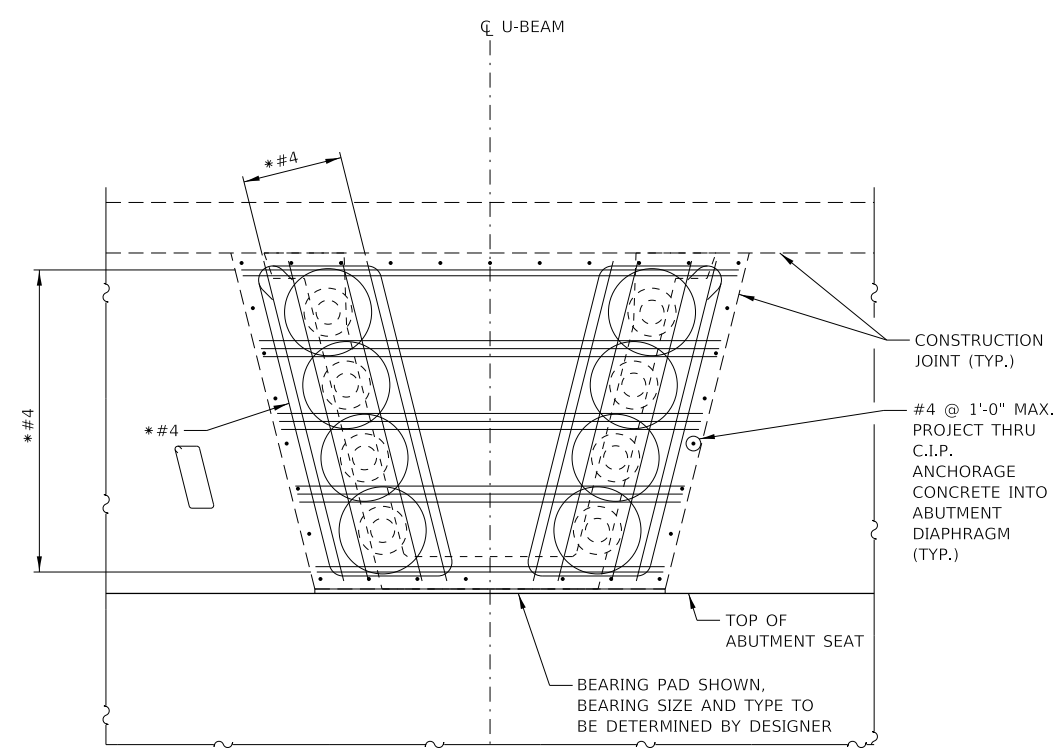

END VIEW
(INTEGRAL ABUTMENT)

NOTE TO DESIGNER

THIS BASE SHEET SHOWS TYPICAL CONSTRUCTION BUT IT IS NOT A STANDARD DRAWING. IT REQUIRES COMPLETION BY THE DESIGNER PRIOR TO INSERTION INTO A CONTRACT. MICROSTATION FILES AND THE "CADD STANDARDS MANUAL" ARE AVAILABLE ON THE ILLINOIS TOLLWAY WEBSITE. THE DESIGNER SHALL ACCEPT THE RESPONSIBILITY OF THE DESIGN OF THIS SHEET UPON ITS COMPLETION AND INSERTION INTO A CONTRACT. ALL "NOTE TO DESIGNER" BOXES SHALL BE REMOVED BY THE DESIGNER PRIOR TO INSERTION OF THE SHEET INTO THE PLAN SET.

NOTE TO DESIGNER

BAR SIZES NOTED WITH (*) ARE A FUNCTION OF THE DESIGN REQUIREMENTS AND MAY VARY.



72IN. AND 84IN. PPC U-BEAM POST-TENSIONED

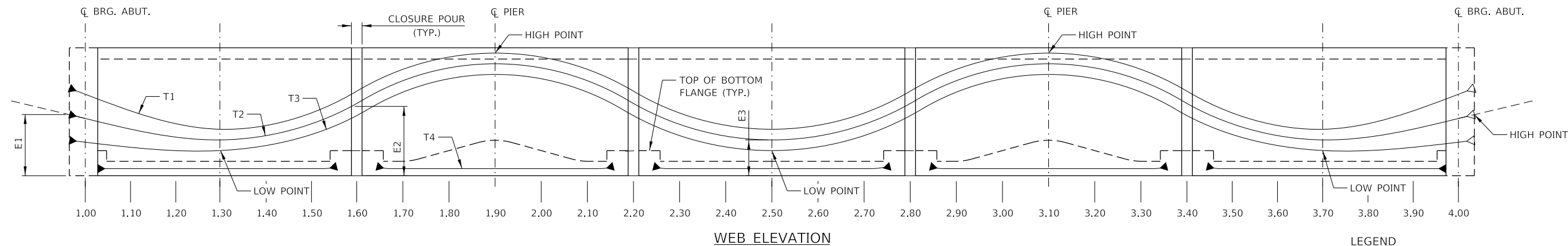

LEGEND
 ———— - DENOTES LIVE END
 - - - - - - - DENOTES DEAD END

		LOCATION																															
TENDON		1.00	1.10	1.20	1.30	1.40	1.50	1.60	1.70	1.80	1.90	2.00	2.10	2.20	2.30	2.40	2.50	2.60	2.70	2.80	2.90	3.00	3.10	3.20	3.30	3.40	3.50	3.60	3.70	3.80	3.90	4.00	
T1	X.XX'																																
T2	X.XX'																																
T3	X.XX'																																
T4	X.XX'																																

TENDON PROFILE

POST-TENSIONING TABLE										
SPAN NO.	GIRDER NO.	MIN. COMPRESSIVE STRENGTH (KSI)		NUMBER OF STRANDS	PRESTRESSING LOAD (KSI)		TOTAL PRESTRESSING LOSS (KSI)	E1 (in)	E2 (in)	E3 (in)
		f'c	f'ci		JACKING	AFTER SEATING				

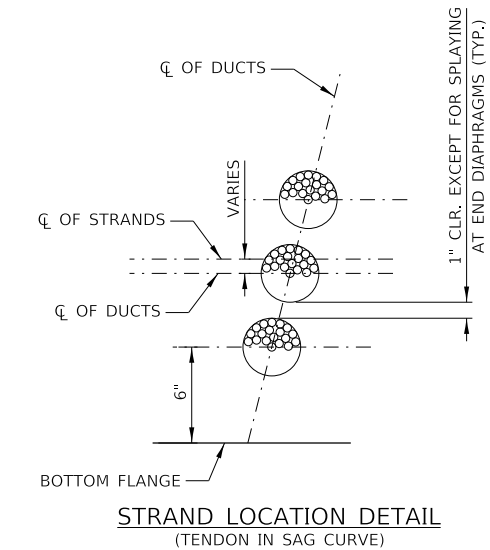

NOTES:

REINFORCING THAT INTERFERES WITH THE PRESTRESSING TENDON ALIGNMENT SHALL BE ADJUSTED AS APPROVED BY THE ENGINEER.

WHERE DEAD END ANCHORAGE AND TENDONS ARE ACCESSIBLE, THE ANCHORAGE SYSTEM AND LENGTH OF PROJECTING PRESTRESSING STEEL SHALL PERMIT JACKING WITH THE SAME JACKING EQUIPMENT THAT WAS USED ON THE LIVE END.

DEVIATIONS FROM THE DUCT PATTERN, DUCT SIZE, AND STRAND SIZE ASSUMED IN THE DESIGN MUST BE APPROVED BY THE ENGINEER.

THE DEFLECTION SHOWN IS POSITIVE DOWNWARD. IT INCLUDES THE INSTANTANEOUS EFFECTS OF DEAD LOAD AND PRESTRESSING, AND A FACTOR OF THREE (3) MULTIPLIER TO ACCOUNT FOR LONG TERM CREEP. FORMED WEB ELEVATIONS MUST BE ADJUSTED UPWARD FOR AN INDICATED POSITIVE DEFLECTION.

STRESSING SEQUENCE:

CONTRACTOR SHALL SUBMIT THE STRESSING AND ELONGATION CALCULATIONS TO THE ENGINEER FOR APPROVAL. ALL LOSSES DUE TO TENDON VERTICAL AND HORIZONTAL CURVATURES MUST BE INCLUDED IN ELONGATION CALCULATIONS. THE STRESSING SEQUENCE SHALL MEET THE FOLLOWING CRITERIA.

- TENDONS MAY BE JACKED FROM BOTH ENDS, EITHER SIMULTANEOUSLY OR SEQUENTIALLY, OR 1/2 THE TENDONS MAY BE JACKED FROM EACH END. IF THE TENDONS ARE JACKED FROM EACH END THE JACKING FORCE SHALL BE INCREASED ___ KIPS. IF JACKING FORCE OR STEEL AREA IS GREATER THAN ASSUMED IN THE DESIGN, PRESTRESSING QUANTITIES SHALL NOT BE ADJUSTED.
- NO MORE THAN 1/2 OF THE PRESTRESSING FORCE IN ANY WEB MAY BE STRESSED BEFORE AN EQUAL FORCE IS STRESSED IN THE ADJACENT WEBS. AT NO TIME DURING THE STRESSING OPERATIONS WILL MORE THAN 10% OF THE TOTAL PRESTRESSING FORCE BE APPLIED ECCENTRICALLY ABOUT THE CENTERLINE OF THE STRUCTURE.
- AT THE CONTRACTORS OPTION, THE PRESTRESSING FORCE MAY VARY ±5% FROM THE THEORETICAL FORCE PER WEB PROVIDED THE TOTAL P(JACK) FORCE IS OBTAINED AND IS DISTRIBUTED SYMMETRICALLY ABOUT THE CENTERLINE OF THE TYPICAL SECTION. P(JACK) IS THE SUM OF THE PEAK FORCES REACHED DURING JACKING IN EACH TENDON.
- BOTTOM FLANGE TENDONS TO BE STRESSED AT CASTING YARD OR ON SITE BEFORE CLOSURE POURS ARE FORMED AND CAST.

POST-TENSIONING NOTES:

THE MINIMUM COMPRESSIVE STRENGTH OF THE CAST-IN-PLACE CONCRETE AT THE CLOSURE AT THE TIME OF POST-TENSIONING SHALL BE AS SHOWN IN POST-TENSIONING TABLE.

THE MAXIMUM OUTSIDE DIAMETER OF THE DUCT SHALL BE ----- INCHES. THE AREA OF THE DUCT SHALL BE AT LEAST 2.5 TIMES THE NET AREA OF THE PRESTRESSING STEEL IN THE DUCT.

THE DESIGN IS BASED ON 0.6" DIA. LOW RELAXATION STRANDS MEETING THE REQUIREMENT OF ASTM A416 GRADE 270 WITH AN ANCHOR SET OF 3/8", A CURVATURE FRICTION COEFFICIENT, K=0.0002/FT. THE ACTUAL ANCHOR SET AND JACKING FORCE USED BY THE CONTRACTOR SHALL BE SPECIFIED IN THE SHOP PLANS AND INCLUDED IN THE TRANSFER FORCE CALCULATIONS.

THE DESIGN IS BASED ON THE ESTIMATED PRESTRESS LOSS OF POST-TENSIONING STRANDS SHOWN IN THE POST-TENSIONING TABLE DUE TO STEEL RELAXATION, ELASTIC SHORTENING CREEP AND SHRINKAGE OF CONCRETE.

STRAND LOCATION DETAIL
(TENDON IN SAG CURVE)

NOTE TO DESIGNER

THIS BASE SHEET SHOWS TYPICAL CONSTRUCTION BUT IT IS NOT A STANDARD DRAWING. IT REQUIRES COMPLETION BY THE DESIGNER PRIOR TO INSERTION INTO A CONTRACT. MICROSTATION FILES AND THE "CADD STANDARDS MANUAL" ARE AVAILABLE ON THE ILLINOIS TOLLWAY WEBSITE. THE DESIGNER SHALL ACCEPT THE RESPONSIBILITY OF THE DESIGN OF THIS SHEET UPON ITS COMPLETION AND INSERTION INTO A CONTRACT. ALL "NOTE TO DESIGNER" BOXES SHALL BE REMOVED BY THE DESIGNER PRIOR TO INSERTION OF THE SHEET INTO THE PLAN SET.

72IN. AND 84IN. PPC U-BEAM POST-TENSIONED

VERSION: 2019-03 STANDARD: M-BRG-523 SHEET: 3 OF 3

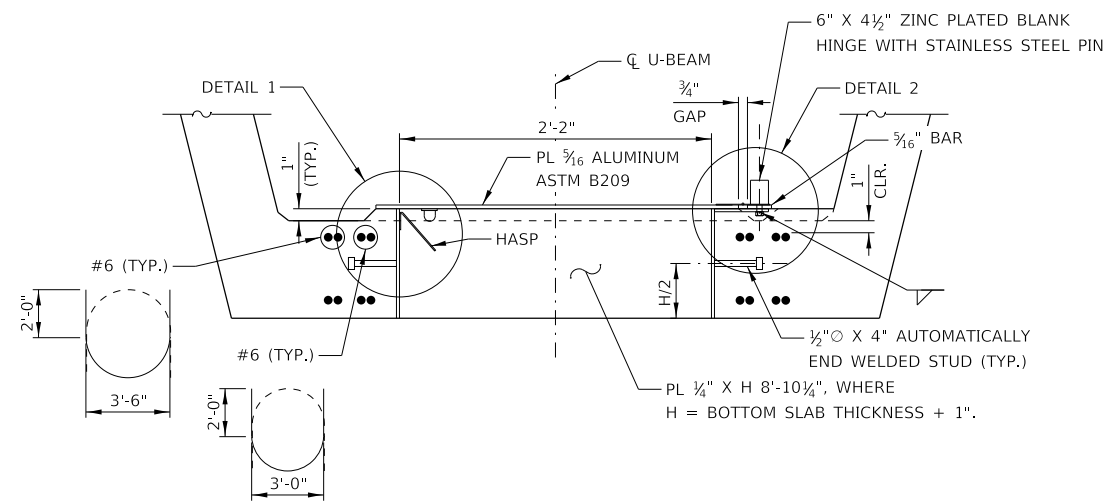

SECTION THROUGH ACCESS DOOR

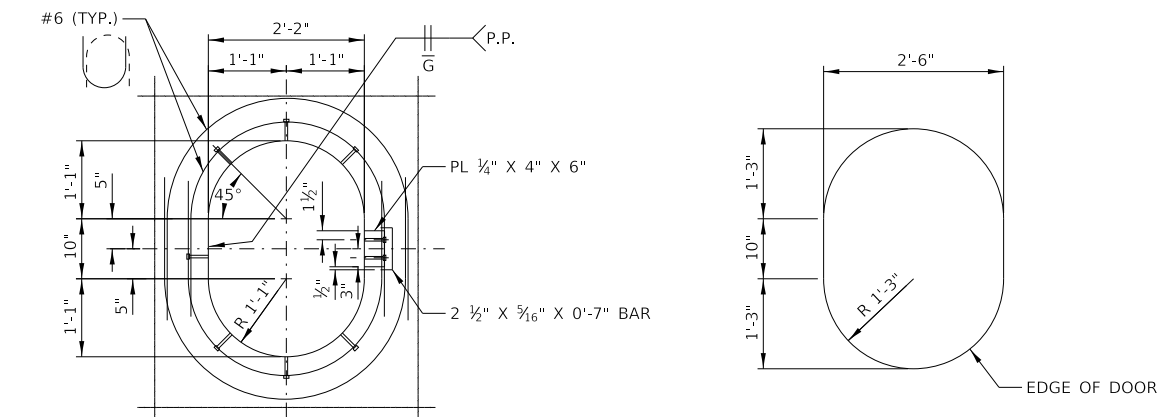

ACCESS DOOR DETAILS

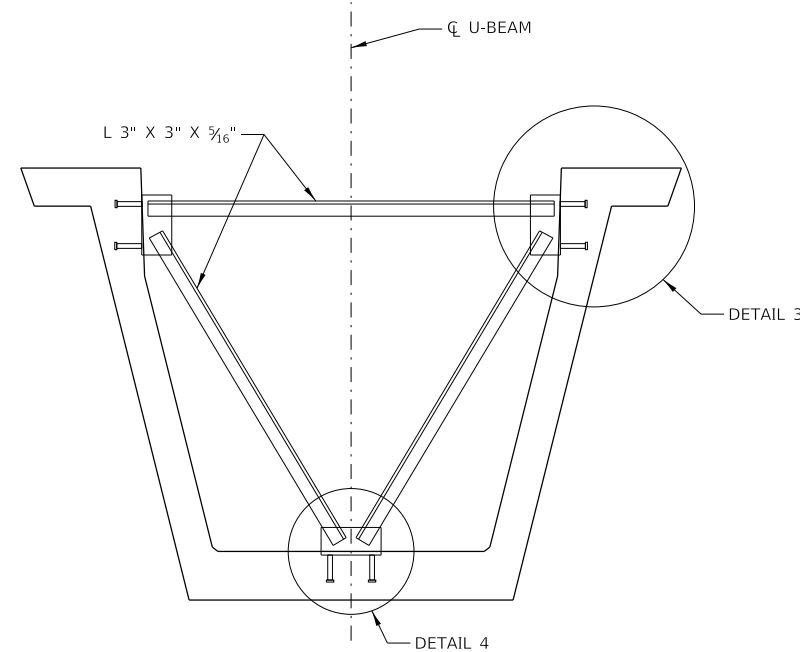

LIFTING DIAPHRAGM

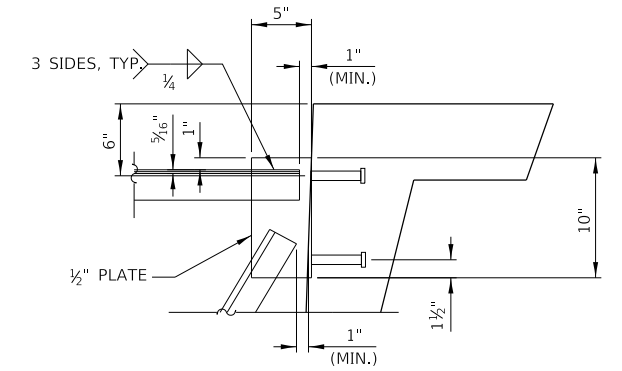

DETAIL 3

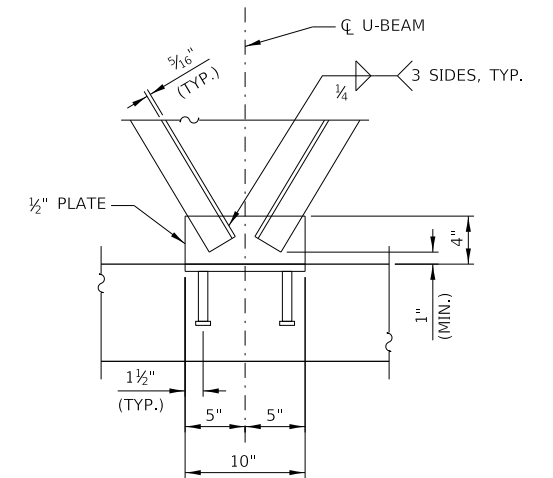

DETAIL 4

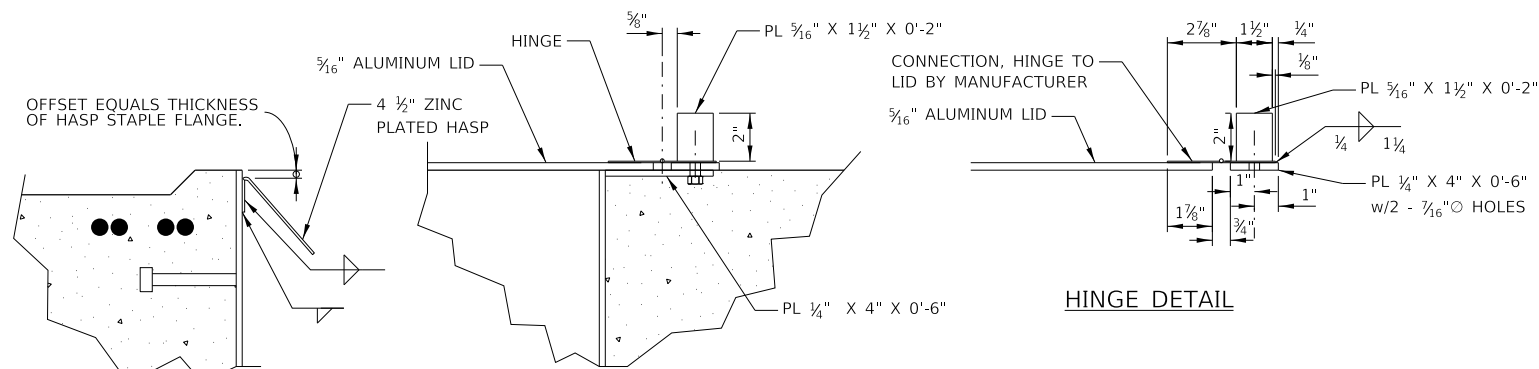

HINGE DETAIL

DETAIL 1

DETAIL 2

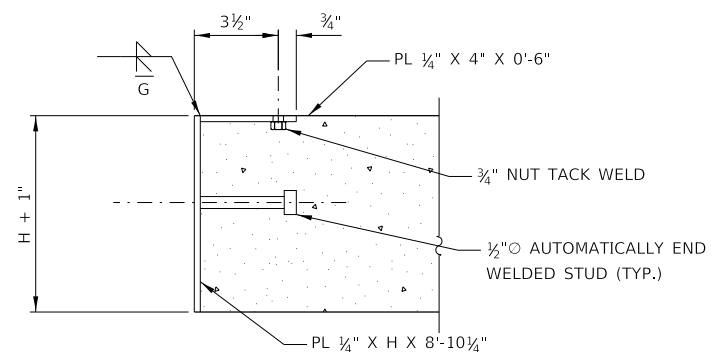

SECTION

NOTE TO DESIGNER

THIS BASE SHEET SHOWS TYPICAL CONSTRUCTION BUT IT IS **NOT** A STANDARD DRAWING. IT REQUIRES COMPLETION BY THE DESIGNER PRIOR TO INSERTION INTO A CONTRACT. MICROSTATION FILES AND THE "CADD STANDARDS MANUAL" ARE AVAILABLE ON THE ILLINOIS TOLLWAY WEBSITE. THE DESIGNER SHALL ACCEPT THE RESPONSIBILITY OF THE DESIGN OF THIS SHEET UPON ITS COMPLETION AND INSERTION INTO A CONTRACT. ALL "NOTE TO DESIGNER" BOXES SHALL BE REMOVED BY THE DESIGNER PRIOR TO INSERTION OF THE SHEET INTO THE PLAN SET.



PPC U-BEAM MISCELLANEOUS DETAILS

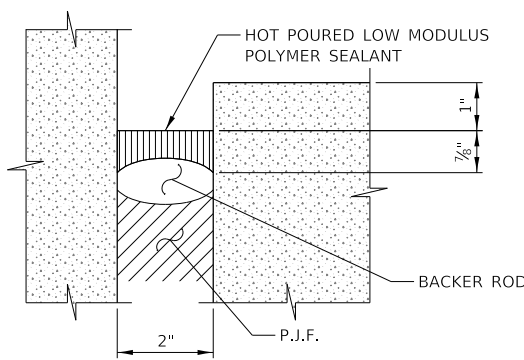
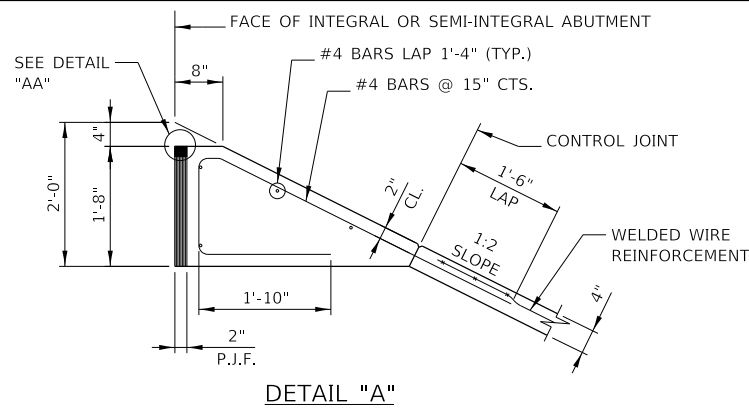

NOTE:
SEALANT, BACKER ROD AND P.J.F. SHALL MEET THE REQUIREMENTS OF SECTIONS 1050 AND 1051 OF THE STANDARD SPECIFICATIONS.

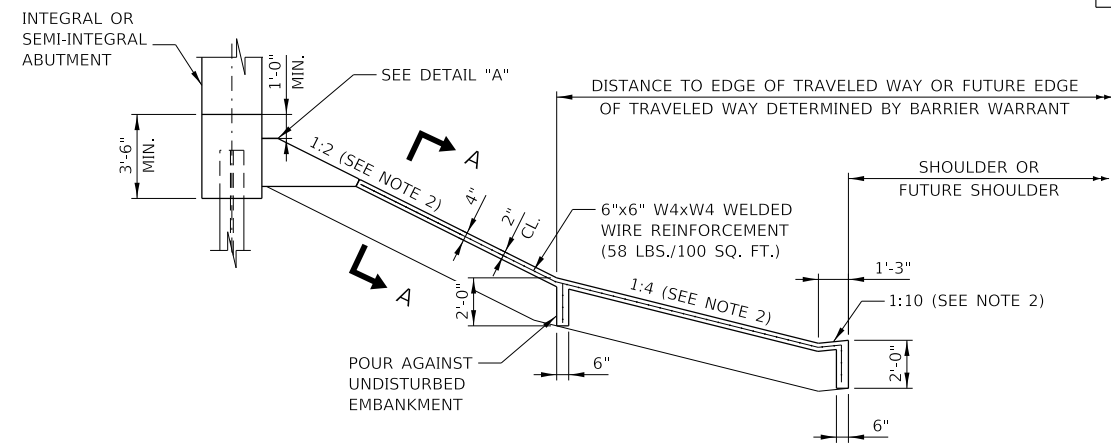
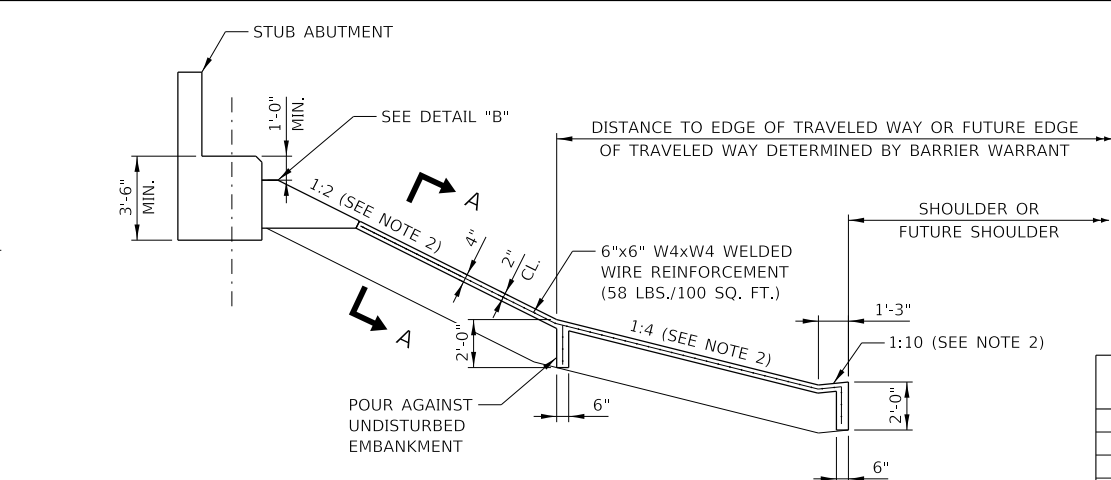

SLOPE WALLS FOR BRIDGES OVER ILLINOIS TOLLWAY

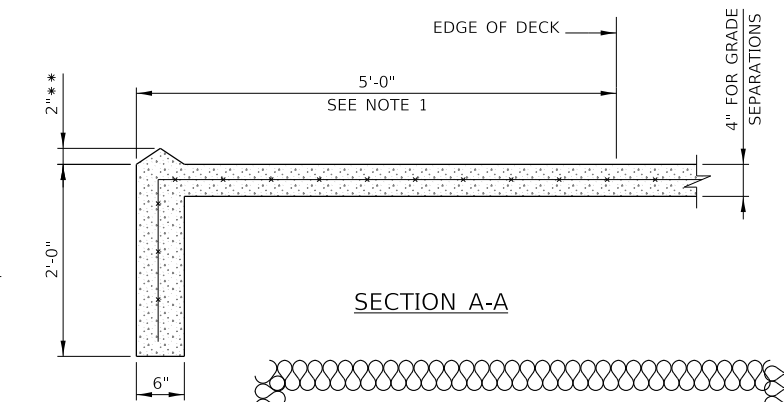
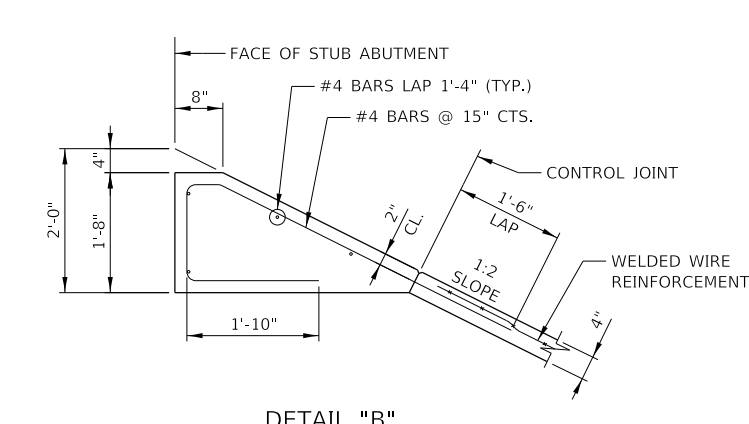

NOTE TO DESIGNER
**THIS DIMENSION SHALL BE INCREASED TO 4" FOR STRUCTURES WITH SKEWS OF 10° OR GREATER AND DRAINAGE ELEMENTS THAT OUTLET ONTO SLOPEWALL.

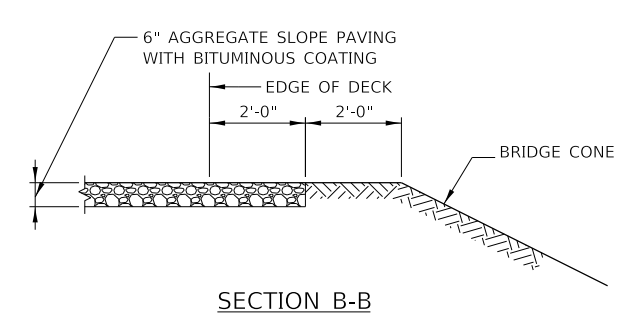

SECTION B-B

NOTE TO DESIGNER
THIS BASE SHEET SHOWS TYPICAL CONSTRUCTION BUT IT IS NOT A STANDARD DRAWING. IT REQUIRES COMPLETION BY THE DESIGNER PRIOR TO INSERTION INTO A CONTRACT. MICROSTATION FILES AND THE "CADD STANDARDS MANUAL" ARE AVAILABLE ON THE ILLINOIS TOLLWAY WEBSITE. THE DESIGNER SHALL ACCEPT THE RESPONSIBILITY OF THE DESIGN OF THIS SHEET UPON ITS COMPLETION AND INSERTION INTO A CONTRACT. ALL "NOTE TO DESIGNER" BOXES SHALL BE REMOVED BY THE DESIGNER PRIOR TO INSERTION OF THE SHEET INTO THE PLAN SET.

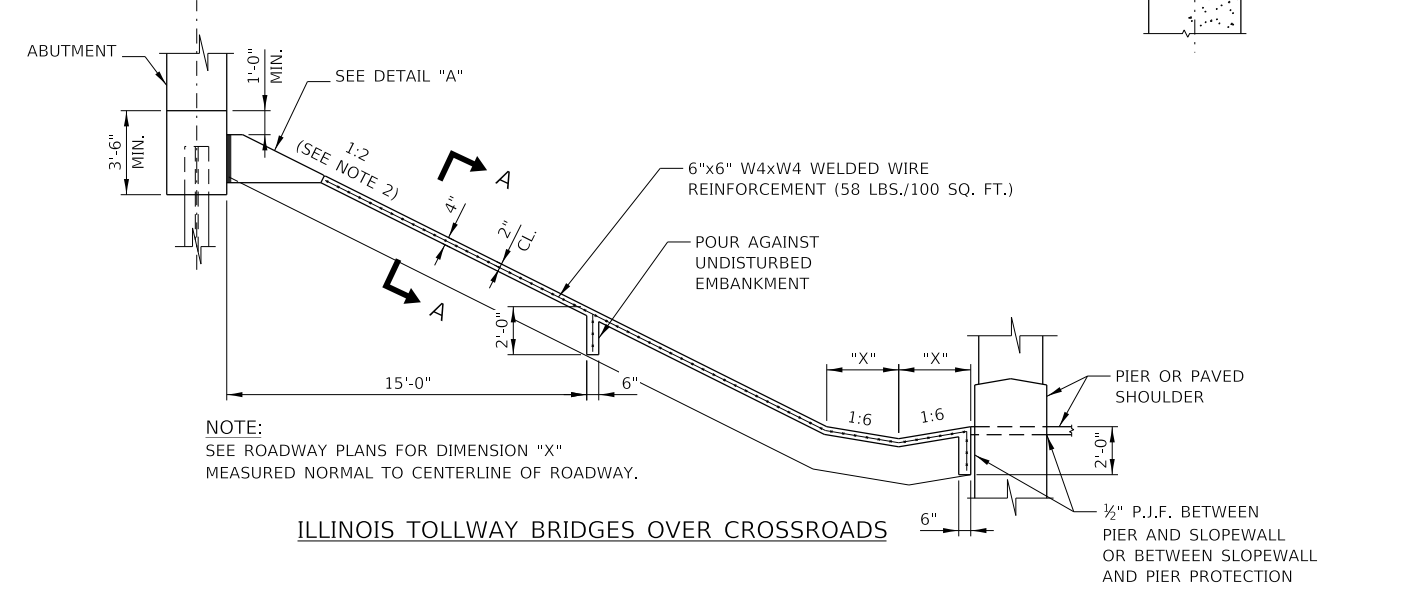

NOTE:
SEE ROADWAY PLANS FOR DIMENSION "X" MEASURED NORMAL TO CENTERLINE OF ROADWAY.

ILLINOIS TOLLWAY BRIDGES OVER CROSSROADS

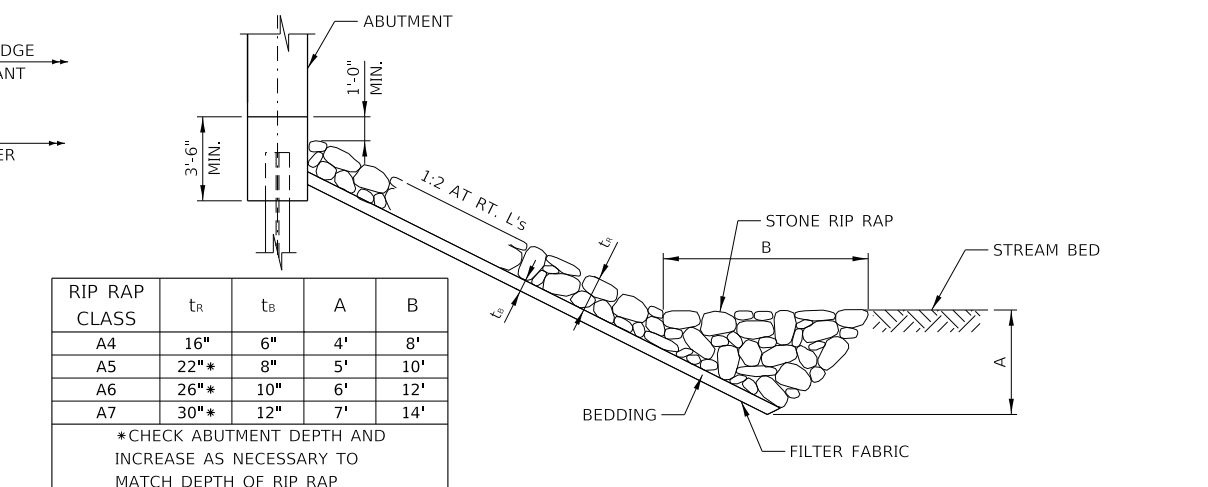

RIP RAP CLASS	t _r	t _b	A	B
A4	16"	6"	4'	8'
A5	22"*	8"	5'	10'
A6	26"*	10"	6'	12'
A7	30"*	12"	7'	14'

*CHECK ABUTMENT DEPTH AND INCREASE AS NECESSARY TO MATCH DEPTH OF RIP RAP

ILLINOIS TOLLWAY BRIDGES OVER WATERWAYS

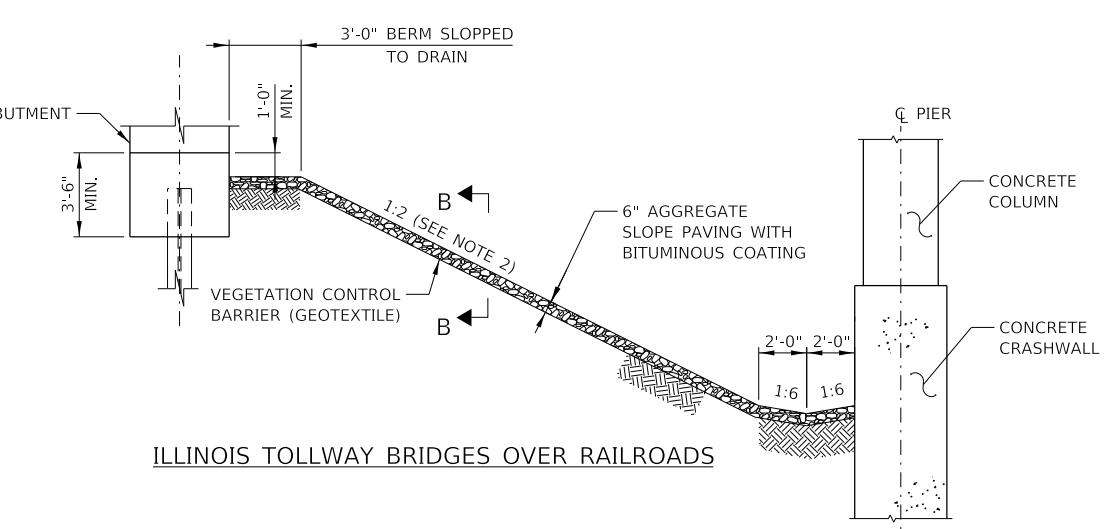

ILLINOIS TOLLWAY BRIDGES OVER RAILROADS

- NOTES:
1. DIMENSIONS SHALL BE 2'-0" IF DECK DRAINS ARE NOT PROVIDED.
 2. DIMENSIONS MARKED THUS ARE MEASURED NORMAL TO CENTERLINE OF ROADWAY OR TRACK.
 3. ALL SLOPES ARE EXPRESSED AS UNITS OF VERTICAL DISPLACEMENT TO UNITS OF HORIZONTAL DISPLACEMENT (V:H).

SLOPEWALL DETAILS

VERSION: 2024-03 STANDARD: M-BRG-525 SHEET: 1 OF 1

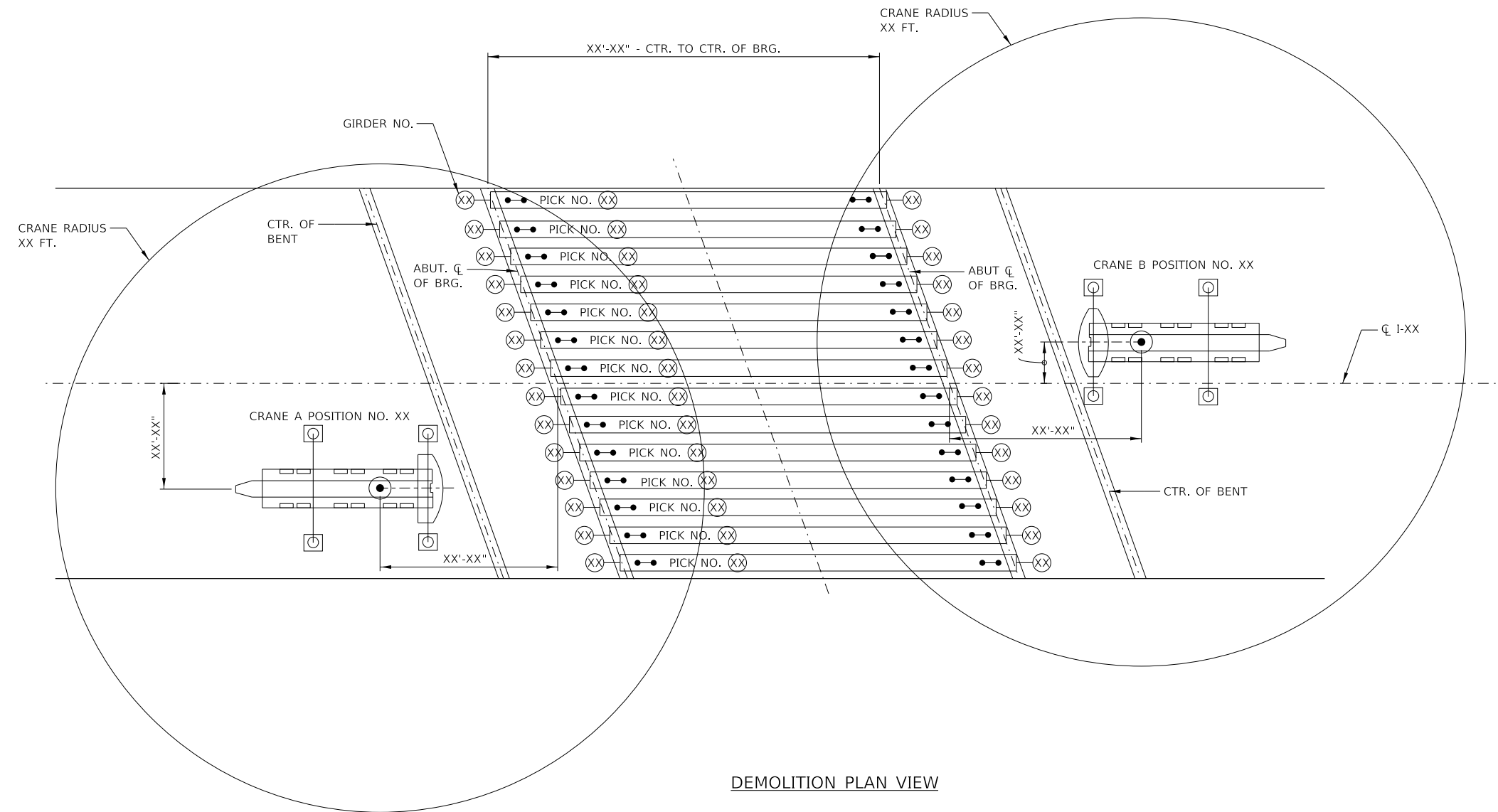

DEMOLITION PLAN VIEW



NOTE TO DESIGNER

THIS BASE SHEET SHOWS TYPICAL CONSTRUCTION BUT IT IS NOT A STANDARD DRAWING. IT REQUIRES COMPLETION BY THE DESIGNER PRIOR TO INSERTION INTO A CONTRACT. MICROSTATION FILES AND THE "CADD STANDARDS MANUAL" ARE AVAILABLE ON THE ILLINOIS TOLLWAY WEBSITE. THE DESIGNER SHALL ACCEPT THE RESPONSIBILITY OF THE DESIGN OF THIS SHEET UPON ITS COMPLETION AND INSERTION INTO A CONTRACT. ALL "NOTE TO DESIGNER" BOXES SHALL BE REMOVED BY THE DESIGNER PRIOR TO INSERTION OF THE SHEET INTO THE PLAN SET.

NOTE TO DESIGNER

THIS BASE SHEET DEPICTS DEMOLITION OF CONCRETE GIRDERS, STEEL GIRDERS WOULD BE SIMILAR.

SUGGEST IDENTIFY BEAM WEIGHTS OR PICK WEIGHTS AND IDENTIFY CROSS FRAMES TO BE REMOVED DURING DEMOLITION.

"XX" DESIGNATES DIMENSION VALUES OR INPUT DATA TO BE PROVIDED ON SUBMITTED DRAWING.

SEQUENCE SHALL ADDRESS TEMPORARY BLOCKING, BRACING OR OTHER TEMPORARY SUPPORTS.

SEQUENCE OF LOAD PLACEMENT SHALL CONFIRM STRUCTURE CAN WITHSTAND THE NEW LOADS WITHOUT DAMAGE.

SCOPE OF WORK

1. LOCATION OF WORK ACTIVITIES.
2. LOAD TO BE LIFTED DESCRIPTION DETAIL (LIFTING POINTS, DIMENSIONS OF LOAD, CENTER OF GRAVITY, ETC.)
3. LOAD CALCULATION: LOAD WEIGHT, LIFTING GEAR WEIGHT, HOOK BLOCK WEIGHT, TOTAL WEIGHT, SAFETY FACTOR, CRANE CAPACITY USAGE (LOAD/SAFE WORKING LOAD (SWL)) (%).
4. MAXIMUM CRANE LOAD TO BE USED FOR CRANE PAD SIZE.
5. LIST GROUND ALLOWABLE BEARING PRESSURE AT CRANE LOADING LOCATIONS.
6. SCHEDULE WITH SPECIFIC WORKING HOUR LIMITATIONS.
7. LIST OF OPERATOR/LIFT SUPERVISOR QUALIFICATION.

CRANE INFORMATION:

CRANE "A"-XXX TON HYDRO (OR EQUIVALENT)
 COUNTERWEIGHT XXX,XXX LBS.
 MAIN BOOM = XXX'
 ANTICIPATED MAX WEIGHT XX,XXX LBS.
 CAPACITY AT RADIUS= XX,XXX LBS.
 MAX RADIUS=XX'-X"
 SWING SPEED= XX MPH

CRANE "B"-XXX TON HYDRO (OR EQUIVALENT)
 COUNTERWEIGHT XXX,XXX LBS.
 MAIN BOOM = XXX'
 ANTICIPATED MAX WEIGHT XX,XXX LBS.
 CAPACITY AT RADIUS= XX,XXX LBS.
 MAX RADIUS=XX'-X"
 SWING SPEED=XX MPH.

LIMITATIONS:

1. ACCESS AND EGRESS FOR THE ASSEMBLY AND DISASSEMBLY OF THE CRANE AND THE MATERIALS TO BE LIFTED WILL BE _____.
2. FEDERAL AVIATION ADMINISTRATION (FAA) RESTRICTIONS _____.
3. CRANE REACTIONS___ SITE GROUND IS SUITABLE / NON SUITABLE FOR CRANE OPERATION. PAD SIZE _____.
4. CRANE'S SUPERSTRUCTURE ROTATES 360° WITHOUT COMING INTO CONTACT WITH ANY OBJECT.
5. BOOM DEFLECTION TO BE CONSIDERED ARE _____.
6. ENVIRONMENTAL CONSIDERATIONS (MAXIMUM PERMISSIBLE WIND _____,WEATHER _____, LIGHTNING _____) IN WHICH LIFT OPERATIONS ARE TO BE STOPPED.
7. ELECTRICAL HAZARD (OVERHEAD/UNDERGROUND). CLEARANCE DISTANCES _____. SPOTTER IS REQUIRED/NOT REQUIRED. PUBLIC UTILITY CONTACT REQUIRED (LIST CONTACT INFORMATION).
8. _____
9. _____

DEMOLITION SEQUENCE:

1. "XX"
2. "XX"
3. "XX"
4. "XX"



DEMOLITION PLAN

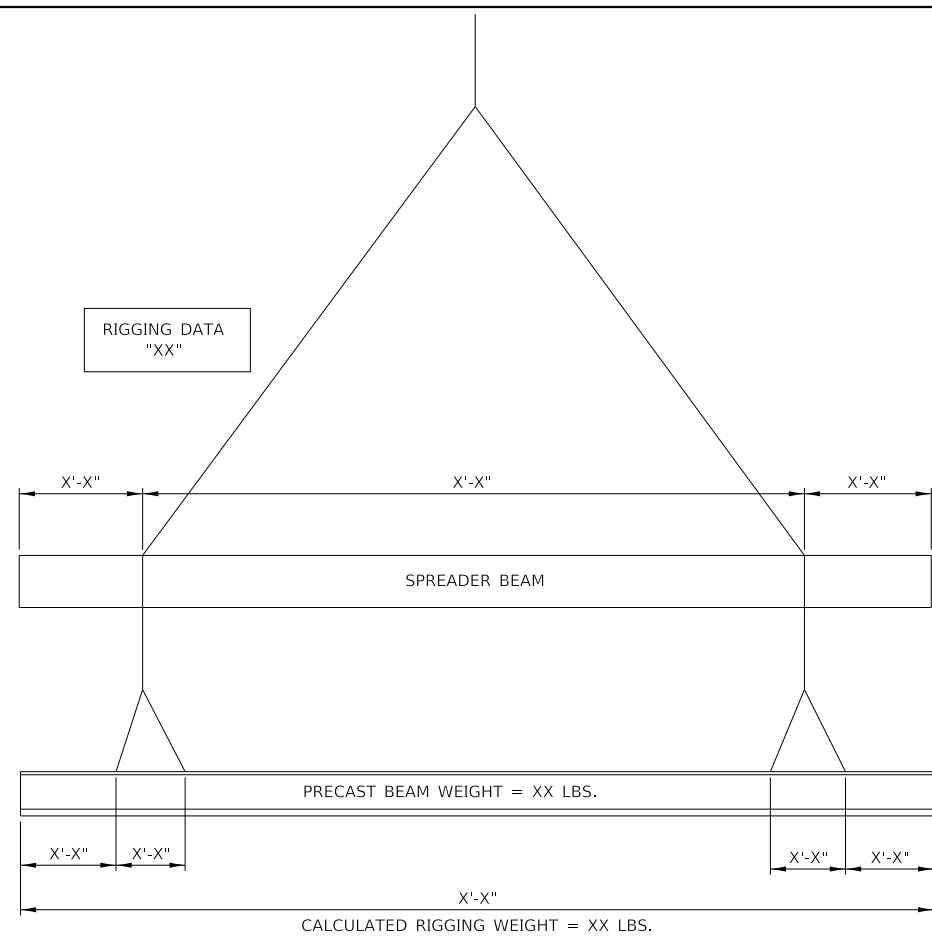

ELEVATION VIEW
 RIGGING DETAILS
 SINGLE CRANE WITH SPREADER BEAM

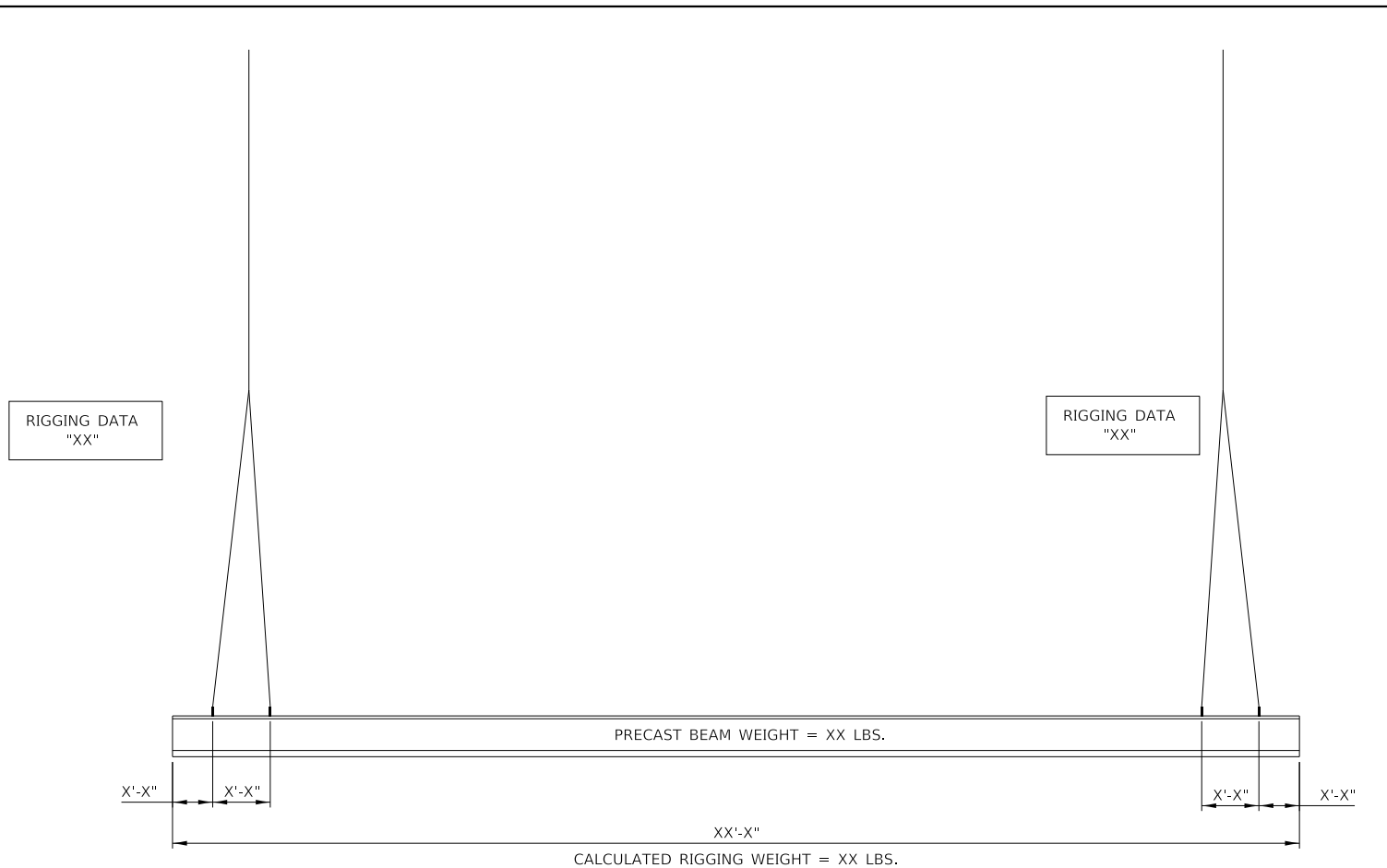

ELEVATION VIEW
 RIGGING DETAILS
 TWO CRANE

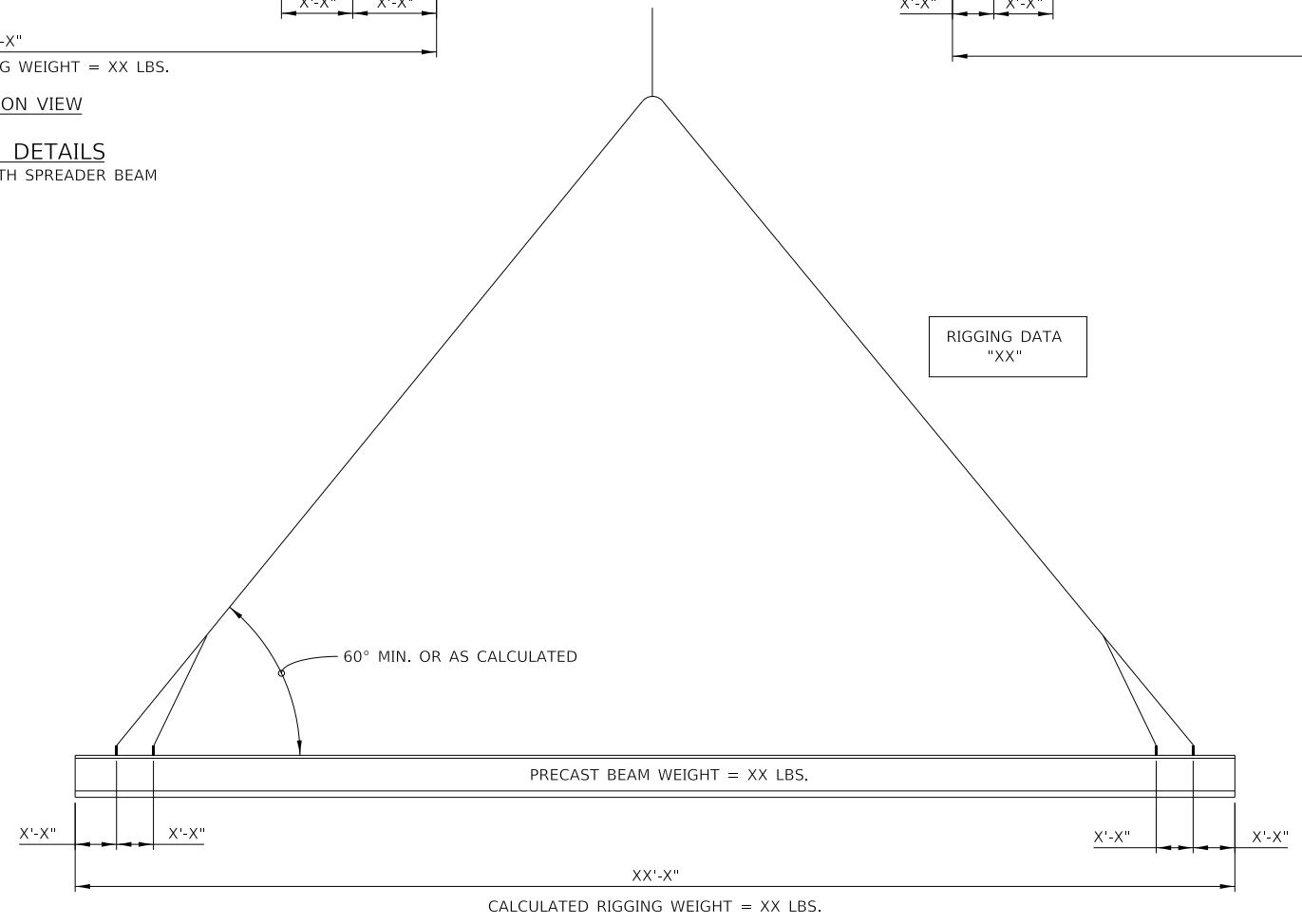

ELEVATION VIEW
 RIGGING DETAILS
 SINGLE CRANE

NOTE TO DESIGNER
 THIS BASE SHEET SHOWS TYPICAL CONSTRUCTION BUT IT IS NOT A STANDARD DRAWING. IT REQUIRES COMPLETION BY THE DESIGNER PRIOR TO INSERTION INTO A CONTRACT. MICROSTATION FILES AND THE "CADD STANDARDS MANUAL" ARE AVAILABLE ON THE ILLINOIS TOLLWAY WEBSITE. THE DESIGNER SHALL ACCEPT THE RESPONSIBILITY OF THE DESIGN OF THIS SHEET UPON ITS COMPLETION AND INSERTION INTO A CONTRACT. ALL "NOTE TO DESIGNER" BOXES SHALL BE REMOVED BY THE DESIGNER PRIOR TO INSERTION OF THE SHEET INTO THE PLAN SET.

NOTE TO DESIGNER
 THIS BASE SHEET DEPICTS DEMOLITION OF CONCRETE GIRDERS, STEEL GIRDERS WOULD BE SIMILAR.
 "XX" DESIGNATES DIMENSION VALUES OR INPUT DATA TO BE PROVIDED ON SUBMITTED DRAWING.
 SPECIFY CENTER OF GRAVITY OF LOAD.



DEMOLITION PLAN

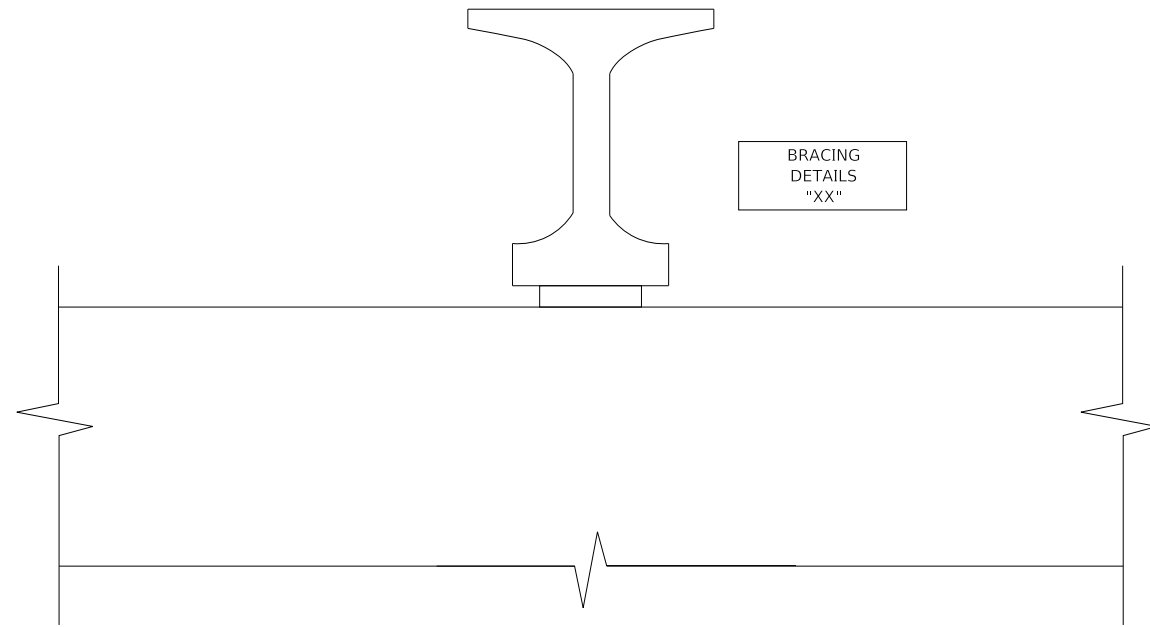

TEMPORARY DEMOLITION
BRACING DETAIL

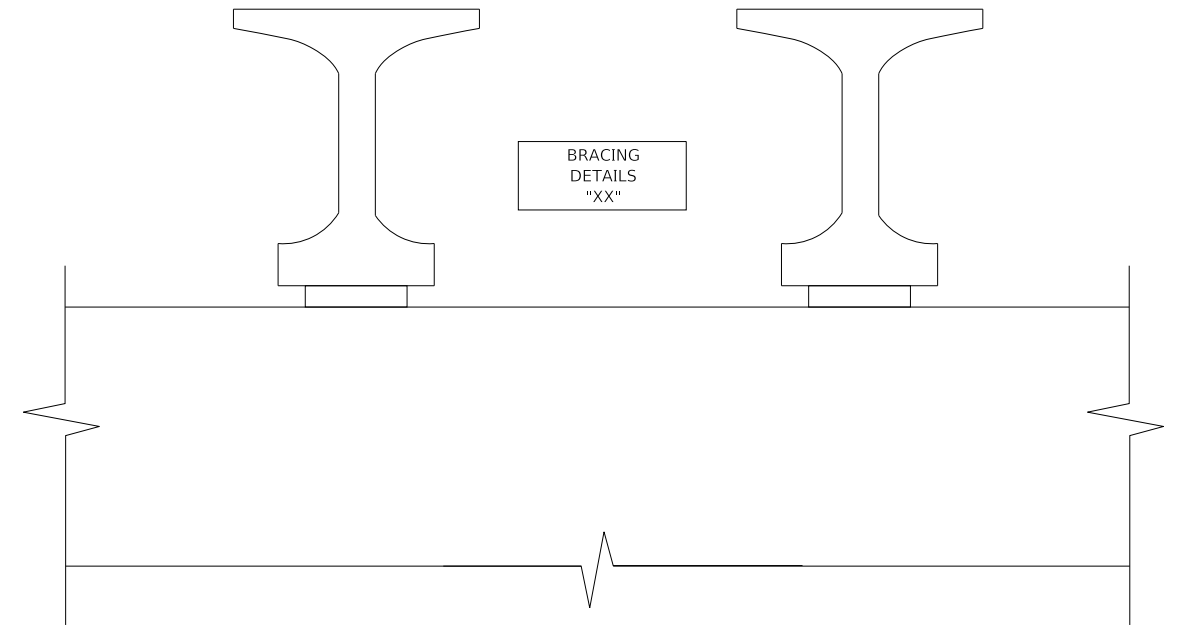

TEMPORARY DEMOLITION
BRACING DETAIL

NOTE TO DESIGNER

THIS BASE SHEET SHOWS TYPICAL CONSTRUCTION BUT IT IS **NOT** A STANDARD DRAWING. IT REQUIRES COMPLETION BY THE DESIGNER PRIOR TO INSERTION INTO A CONTRACT. MICROSTATION FILES AND THE "CADD STANDARDS MANUAL" ARE AVAILABLE ON THE ILLINOIS TOLLWAY WEBSITE. THE DESIGNER SHALL ACCEPT THE RESPONSIBILITY OF THE DESIGN OF THIS SHEET UPON ITS COMPLETION AND INSERTION INTO A CONTRACT. ALL "NOTE TO DESIGNER" BOXES SHALL BE REMOVED BY THE DESIGNER PRIOR TO INSERTION OF THE SHEET INTO THE PLAN SET.

NOTE TO DESIGNER

THIS BASE SHEET DEPICTS DEMOLITION OF CONCRETE GIRDERS. STEEL GIRDERS WOULD BE SIMILAR.
"XX" DESIGNATES DIMENSION VALUES OR INPUT DATA TO BE PROVIDED ON SUBMITTED DRAWING.



DEMOLITION PLAN

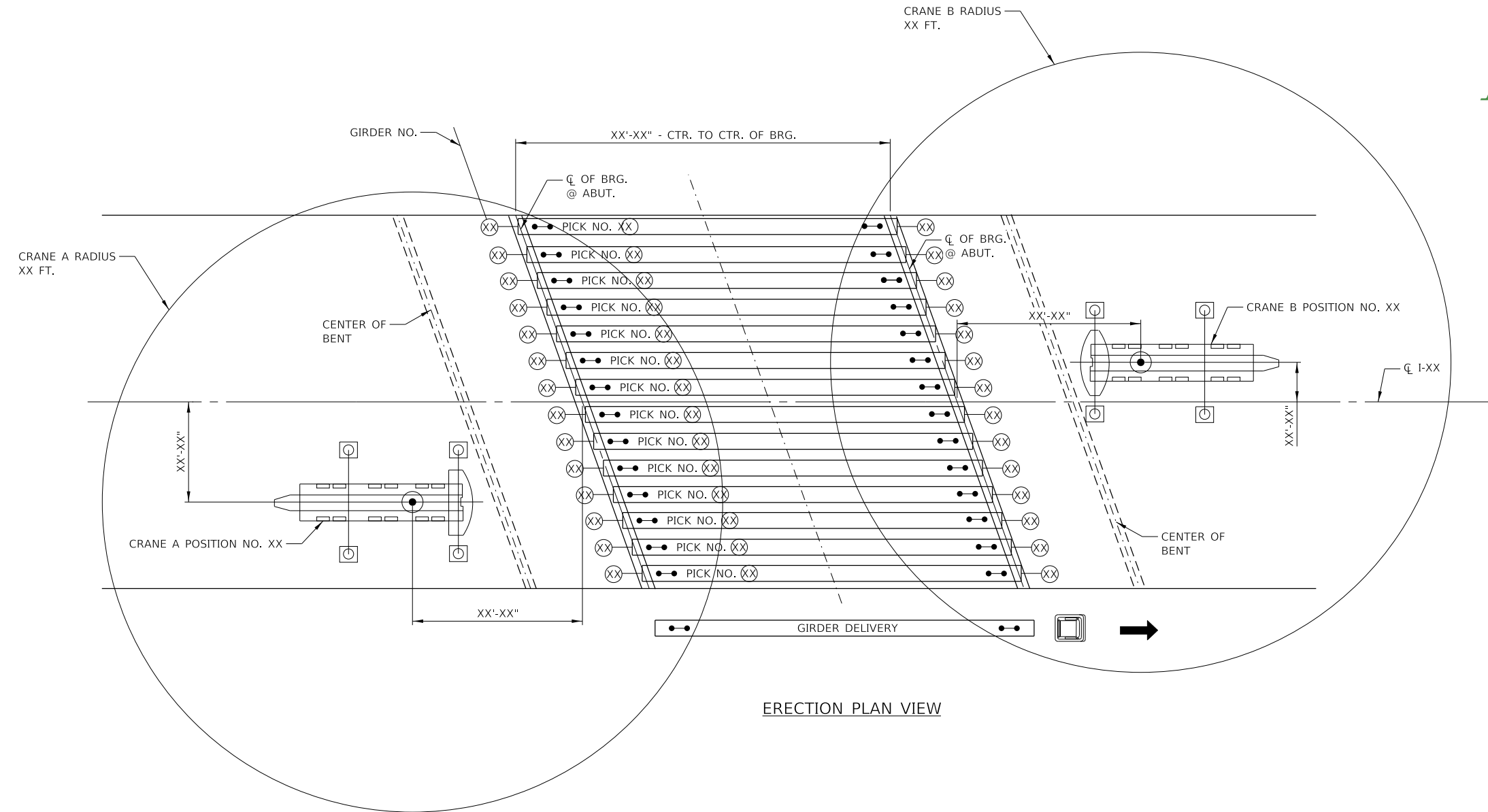

ERECTOR PLAN VIEW

NOTE TO DESIGNER / CONTRACTOR

THIS BASE SHEET SHOWS TYPICAL CONSTRUCTION BUT IT IS NOT A STANDARD DRAWING. THIS SHEET IS TO BE USED AS A GUIDE BY THE CONTRACTOR FOR PREPARATION OF A ERECTION SUBMITTAL PER THE CONTRACT REQUIREMENTS. MICROSTATION FILES ARE AVAILABLE ON THE ILLINOIS TOLLWAY WEBSITE.

- IDENTIFY TEMPORARY SHORING, IDENTIFY TEMPORARY, CROSS FRAMES DURING ERECTION.
- "XX" DESIGNATES DIMENSION VALUES OR PROVIDED DATA TO BE PROVIDED ON SUBMITTED DRAWING.
- SEQUENCE SHALL ADDRESS TEMPORARY BLOCKING, BRACING OR OTHER TEMPORARY SUPPORTS.
- SEQUENCE OF LOAD PLACEMENT SHALL CONFIRM STRUCTURE CAN WITHSTAND THE NEW LOADS WITHOUT DAMAGE.

SCOPE OF WORK:

1. LOCATION OF WORK ACTIVITIES.
2. LOAD TO BE LIFTED DESCRIPTION DETAIL (LIFTING POINTS, DIMENSIONS OF LOAD, CENTER OF GRAVITY, ETC.)
3. LOAD CALCULATION: LOAD WEIGHT, LIFTING GEAR WEIGHT, HOOK BLOCK WEIGHT, TOTAL WEIGHT, SAFETY FACTOR, CRANE CAPACITY USAGE (LOAD/SAFE WORKING LOAD (SWL)) (%).
4. MAXIMUM CRANE LOAD TO BE USED FOR CRANE PAD SIZE.
5. LIST GROUND ALLOWABLE BEARING PRESSURE AT CRANE LOADING LOCATIONS.
6. SCHEDULE WITH SPECIFIC WORKING HOUR LIMITATIONS.
7. LIST OF OPERATOR/LIFT SUPERVISOR QUALIFICATION.

CRANE INFORMATION:

CRANE "A"-XXX TON HYDRO
(OR EQUIVALENT)
COUNTERWEIGHT XXX,XXX LBS.
MAIN BOOM = XXX'
ANTICIPATED MAX WEIGHT XX,XXX LBS.
CAPACITY AT RADIUS= XX,XXX LBS.
MAX RADIUS=XX'-X"
SWING SPEED= XX MPH

CRANE "B"-XXX TON HYDRO
(OR EQUIVALENT)
COUNTERWEIGHT XXX,XXX LBS.
MAIN BOOM = XXX'
ANTICIPATED MAX WEIGHT XX,XXX LBS.
CAPACITY AT RADIUS= XX,XXX LBS.
MAX RADIUS=XX'-X"
SWING SPEED=XX MPH.

LIMITATIONS:

1. ACCESS AND EGRESS FOR THE ASSEMBLY AND DISASSEMBLY OF THE CRANE AND THE MATERIALS TO BE LIFTED WILL BE _____.
2. FEDERAL AVIATION ADMINISTRATION (FAA) RESTRICTIONS _____.
3. CRANE REACTIONS ___ SITE GROUND IS SUITABLE / NON SUITABLE FOR CRANE OPERATION. PAD SIZE _____.
4. CRANE'S SUPERSTRUCTURE ROTATES 360° WITHOUT COMING INTO CONTACT WITH ANY OBJECT.
5. BOOM DEFLECTION TO BE CONSIDERED ARE _____.
6. ENVIRONMENTAL CONSIDERATIONS (MAXIMUM PERMISSIBLE WIND ____, WEATHER ____, LIGHTNING ____) IN WHICH LIFT OPERATIONS ARE TO BE STOPPED.
7. ELECTRICAL HAZARD (OVERHEAD / UNDERGROUND). CLEARANCE DISTANCES ____.
8. SPOTTER IS REQUIRED / NOT REQUIRED. PUBLIC UTILITY CONTACT REQUIRED (LIST CONTACT INFORMATION).
9. _____

ERECTOR SEQUENCE:

1. "XX"
2. "XX"
3. "XX"
4. "XX"



ERECTOR PLAN - CONCRETE

VERSION: 2021-03	STANDARD: M-BRG-527	SHEET: 1 OF 3
---------------------	------------------------	------------------

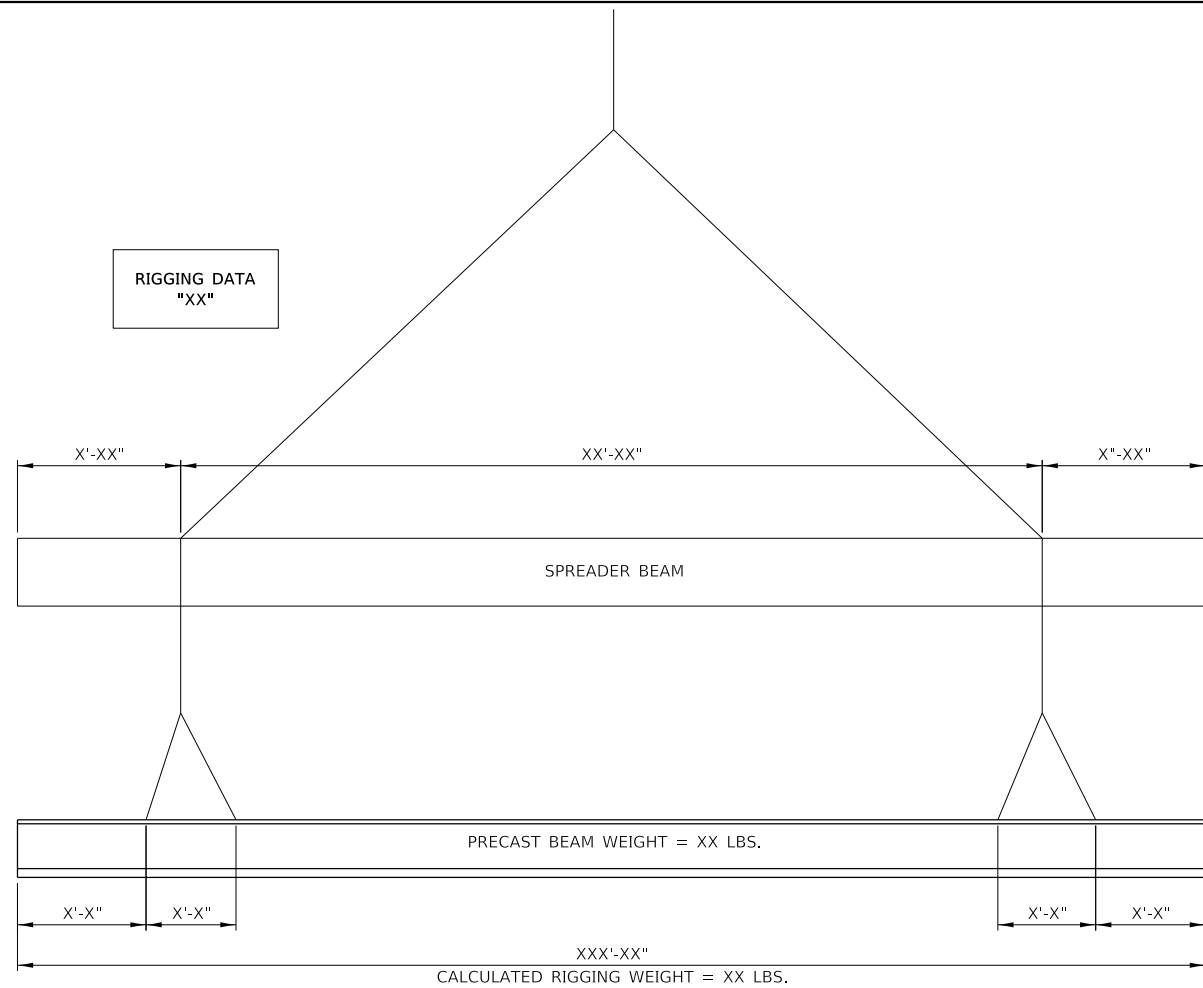

ELEVATION VIEW
RIGGING DETAILS
SINGLE CRANE WITH SPREADER BEAM

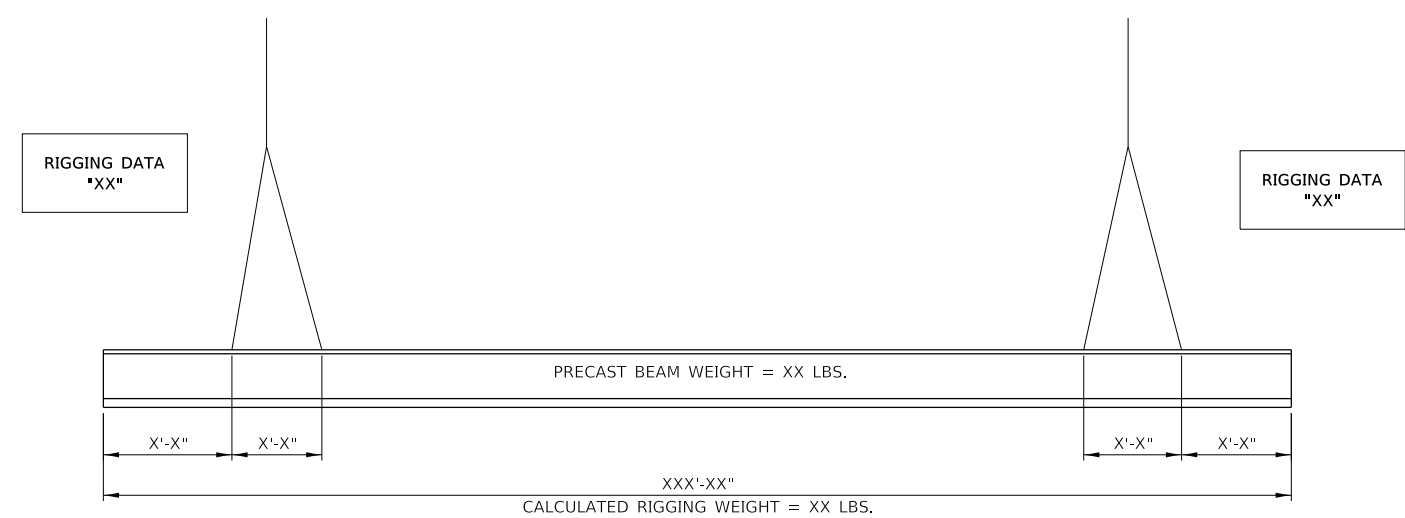

ELEVATION VIEW
RIGGING DETAILS
TWO CRANE

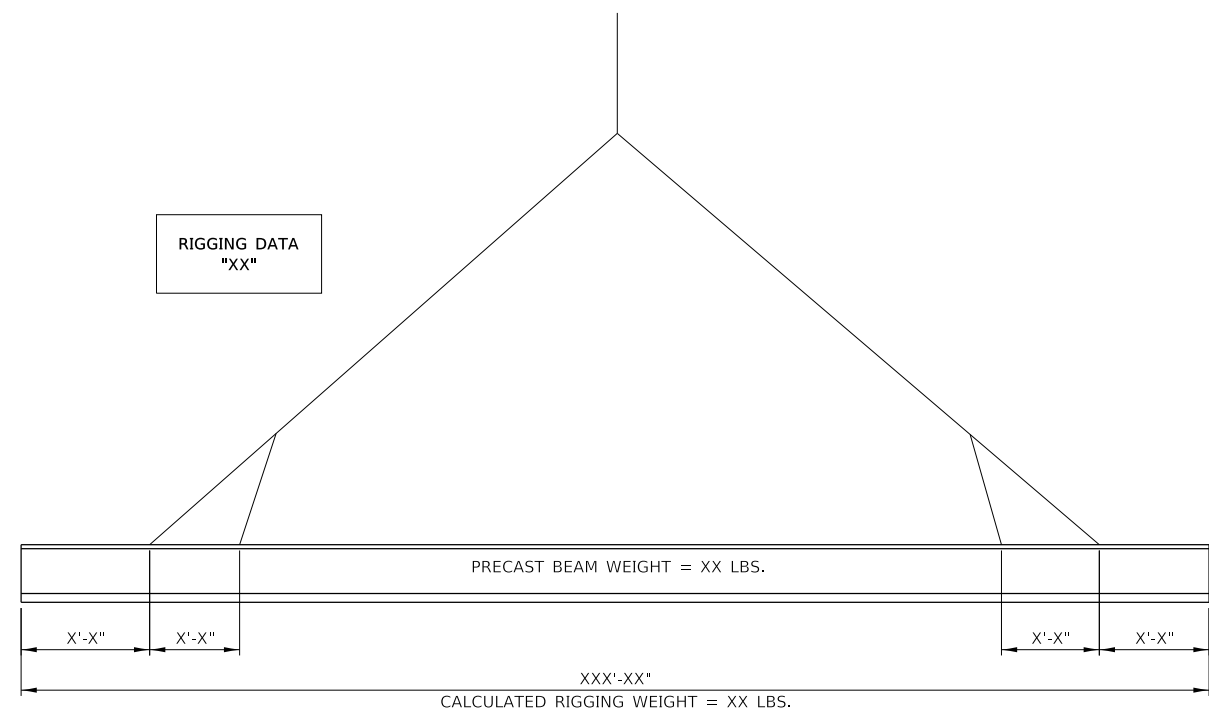

ELEVATION VIEW
RIGGING DETAILS
SINGLE CRANE

NOTE TO DESIGNER / CONTRACTOR

THIS BASE SHEET SHOWS TYPICAL CONSTRUCTION BUT IT IS NOT A STANDARD DRAWING. THIS SHEET IS TO BE USED AS A GUIDE BY THE CONTRACTOR FOR PREPARATION OF AN ERECTION SUBMITTAL PER THE CONTRACT REQUIREMENTS. MICROSTATION FILES ARE AVAILABLE ON THE ILLINOIS TOLLWAY WEBSITE.

- "XX" DESIGNATES DIMENSION VALUES OR PROVIDED DATA TO BE PROVIDED ON SUBMITTED DRAWING.
- SPECIFY CENTER OF GRAVITY OF LOAD.



ERECTION PLAN - CONCRETE

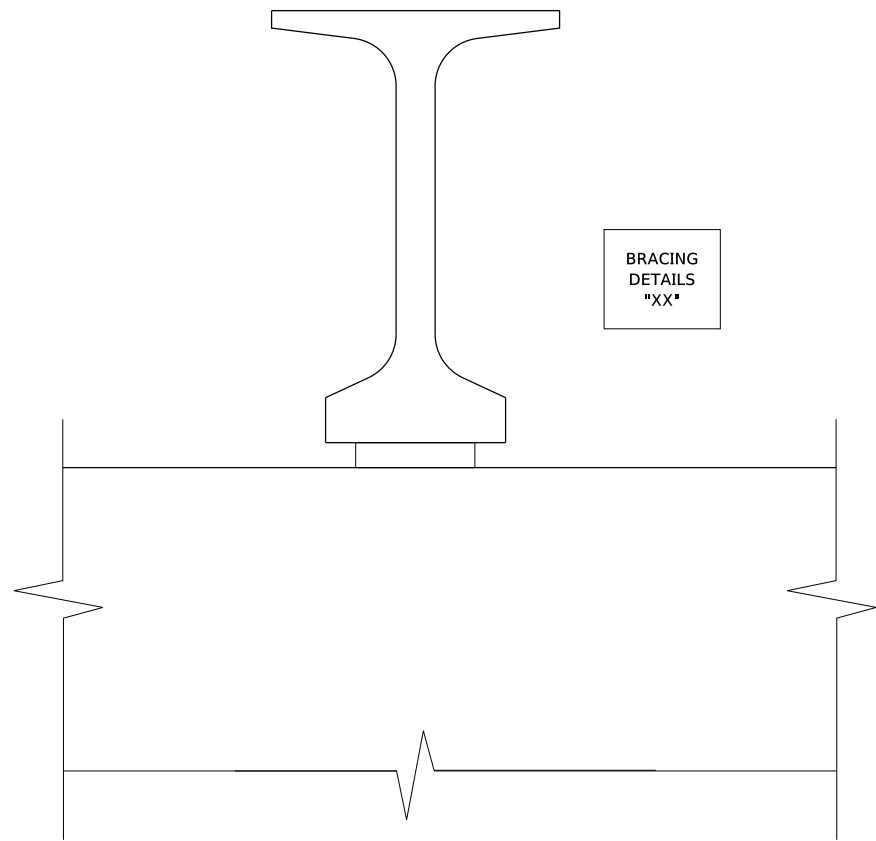

TEMPORARY ERECTION
BRACING DETAIL

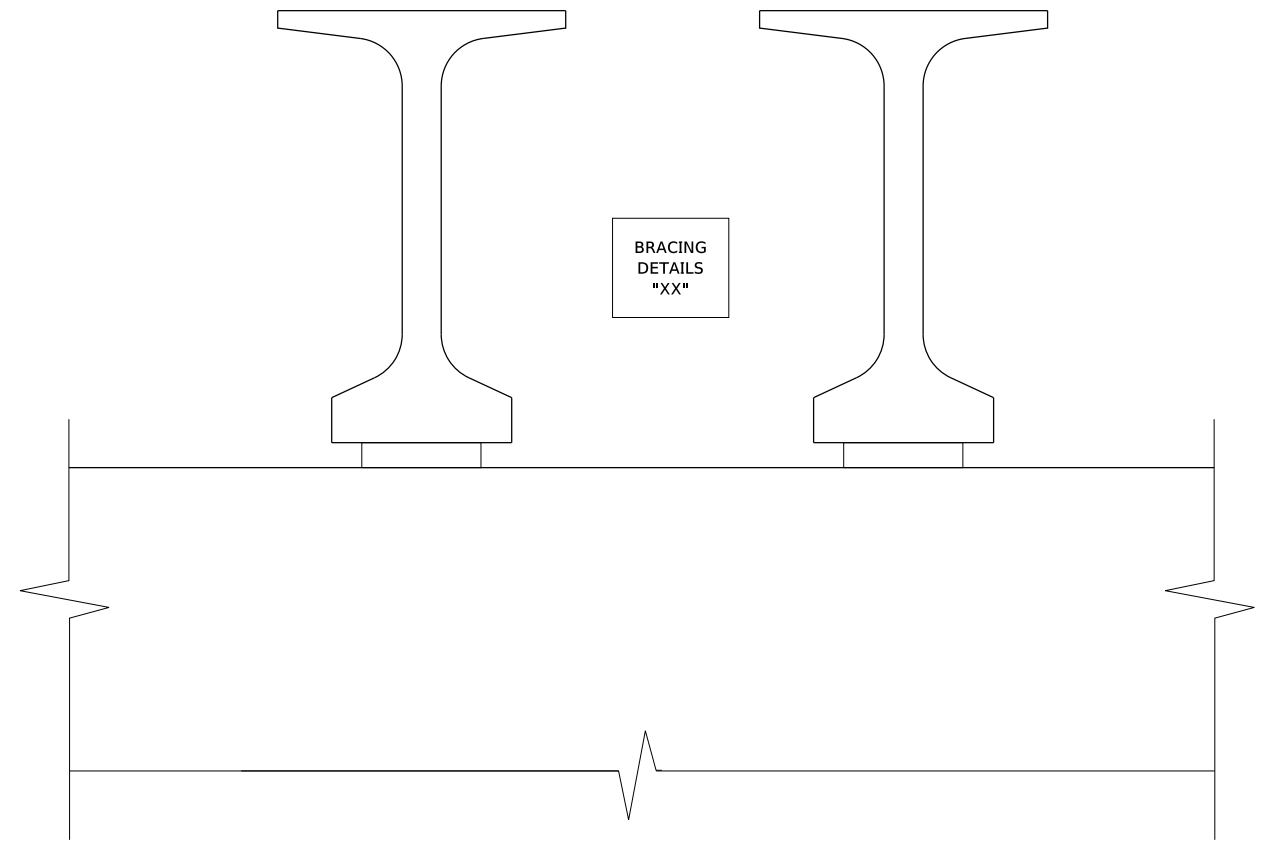

TEMPORARY ERECTION
BRACING DETAIL

NOTE TO DESIGNER / CONTRACTOR

THIS BASE SHEET SHOWS TYPICAL CONSTRUCTION BUT IT IS NOT A STANDARD DRAWING. THIS SHEET IS TO BE USED AS A GUIDE BY THE CONTRACTOR FOR PREPARATION OF AN ERECTION SUBMITTAL PER THE CONTRACT REQUIREMENTS. MICROSTATION FILES ARE AVAILABLE ON THE ILLINOIS TOLLWAY WEBSITE.

•"XX" DESIGNATES DIMENSION VALUES OR PROVIDED DATA TO BE PROVIDED ON SUBMITTED DRAWING.



ERECTION PLAN - CONCRETE

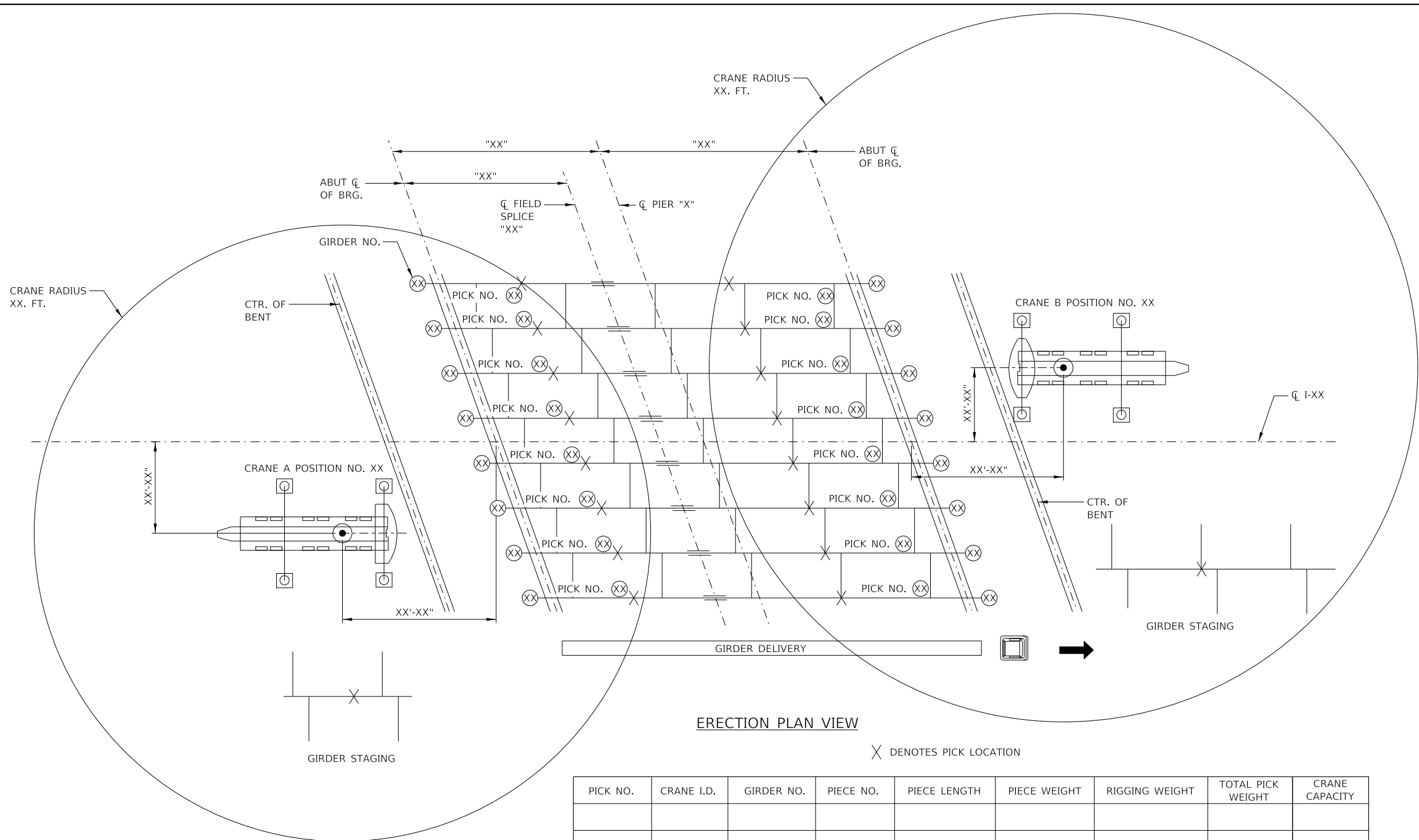

ERECTION PLAN VIEW

X DENOTES PICK LOCATION

PICK NO.	CRANE I.D.	GIRDER NO.	PIECE NO.	PIECE LENGTH	PIECE WEIGHT	RIGGING WEIGHT	TOTAL PICK WEIGHT	CRANE CAPACITY

NOTE TO DESIGNER

THIS BASE SHEET SHOWS TYPICAL CONSTRUCTION BUT IT IS NOT A STANDARD DRAWING. IT REQUIRES COMPLETION BY THE DESIGNER PRIOR TO INSERTION INTO A CONTRACT. MICROSTATION FILES AND THE "CADD STANDARDS MANUAL" ARE AVAILABLE ON THE ILLINOIS TOLLWAY WEBSITE. THE DESIGNER SHALL ACCEPT THE RESPONSIBILITY OF THE DESIGN OF THIS SHEET UPON ITS COMPLETION AND INSERTION INTO A CONTRACT. ALL "NOTE TO DESIGNER" BOXES SHALL BE REMOVED BY THE DESIGNER PRIOR TO INSERTION OF THE SHEET INTO THE PLAN SET.

NOTE TO DESIGNER

IDENTIFY TEMPORARY SHORING, TEMPORARY CROSS FRAMES DURING ERECTION.

"XX" DESIGNATES DIMENSION VALUES OR INPUT DATA TO BE PROVIDED ON SUBMITTED DRAWING.

SEQUENCE SHALL ADDRESS TEMPORARY BLOCKING, BRACING OR OTHER TEMPORARY BRACING SUPPORTS.

SEQUENCE OF LOAD PLACEMENT SHALL CONFIRM STRUCTURE CAN WITHSTAND THE NEW LOADS WITHOUT DAMAGE.

TABLE HEADING AND INFORMATION ARE SUGGESTED AND FOR USE AS A GUIDE FOR PREPARATION OF SUBMITTAL.

SCOPE OF WORK

1. LOCATION OF WORK ACTIVITIES.
2. LOAD TO BE LIFTED DESCRIPTION DETAIL (LIFTING POINTS, DIMENSIONS OF LOAD, CENTER OF GRAVITY, ETC.)
3. LOAD CALCULATION: LOAD WEIGHT, LIFTING GEAR WEIGHT, HOOK BLOCK WEIGHT, TOTAL WEIGHT, SAFETY FACTOR, CRANE CAPACITY USAGE (LOAD/SAFE WORKING LOAD (SWL)) (%).
4. MAXIMUM CRANE LOAD TO BE USED FOR CRANE PAD SIZE.
5. LIST GROUND ALLOWABLE BEARING PRESSURE AT CRANE LOADING LOCATIONS.
6. SCHEDULE WITH SPECIFIC WORKING HOUR LIMITATIONS.
7. LIST OF OPERATOR/LIFT SUPERVISOR QUALIFICATION.

CRANE INFORMATION:

CRANE "A"-XXX TON HYDRO (OR EQUIVALENT)
 COUNTERWEIGHT XXX,XXX LBS.
 MAIN BOOM = XXX'
 ANTICIPATED MAX WEIGHT XX,XXX LBS.
 CAPACITY AT RADIUS= XX,XXX LBS.
 MAX RADIUS=XX'-X"
 SWING SPEED= XX MPH

CRANE "B"-XXX TON HYDRO (OR EQUIVALENT)
 COUNTERWEIGHT XXX,XXX LBS.
 MAIN BOOM = XXX'
 ANTICIPATED MAX WEIGHT XX,XXX LBS.
 CAPACITY AT RADIUS= XX,XXX LBS.
 MAX RADIUS=XX'-X"
 SWING SPEED=XX MPH.

RISK ASSESSMENT & LIMITATIONS:

1. ACCESS AND EGRESS FOR THE ASSEMBLY AND DISASSEMBLY OF THE CRANE AND THE MATERIALS TO BE LIFTED WILL BE _____.
2. FEDERAL AVIATION ADMINISTRATION (FAA) RESTRICTIONS _____.
3. CRANE REACTIONS ___ SITE GROUND IS SUITABLE / NON SUITABLE FOR CRANE OPERATION. PAD SIZE _____.
4. CRANE'S SUPERSTRUCTURE ROTATES 360° WITHOUT COMING INTO CONTACT WITH ANY OBJECT.
5. BOOM DEFLECTION TO BE CONSIDERED ARE _____.
6. ENVIRONMENTAL CONSIDERATIONS (MAXIMUM PERMISSIBLE WIND _____, WEATHER _____, LIGHTNING _____) IN WHICH LIFT OPERATIONS ARE TO BE STOPPED.
7. ELECTRICAL HAZARD (OVERHEAD/UNDERGROUND). CLEARANCE DISTANCES _____. SPOTTER IS REQUIRED/NOT REQUIRED. PUBLIC UTILITY CONTACT REQUIRED (LIST CONTACT INFORMATION).
8. _____
9. _____

ERECTION SEQUENCE:

1. "XX"
2. "XX"
3. "XX"
4. "XX"



ERECTION PLAN - STEEL

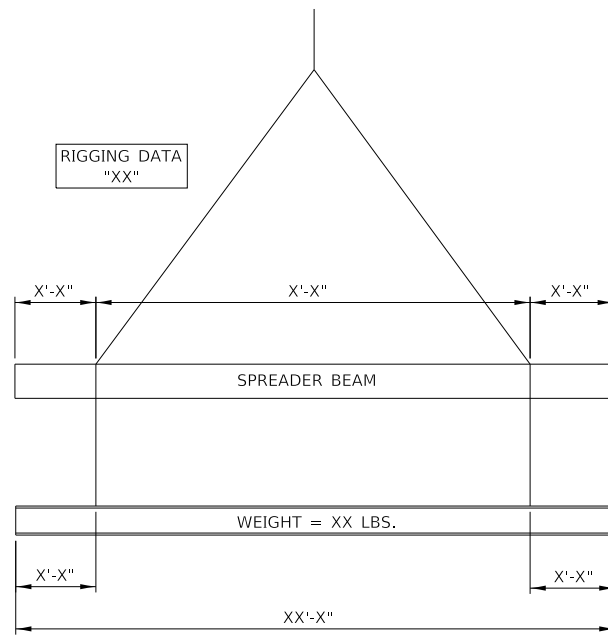

CALCULATED RIGGING WEIGHT = XX LBS.

ELEVATION VIEW

RIGGING DETAILS
SINGLE CRANE WITH SPREADER BEAM

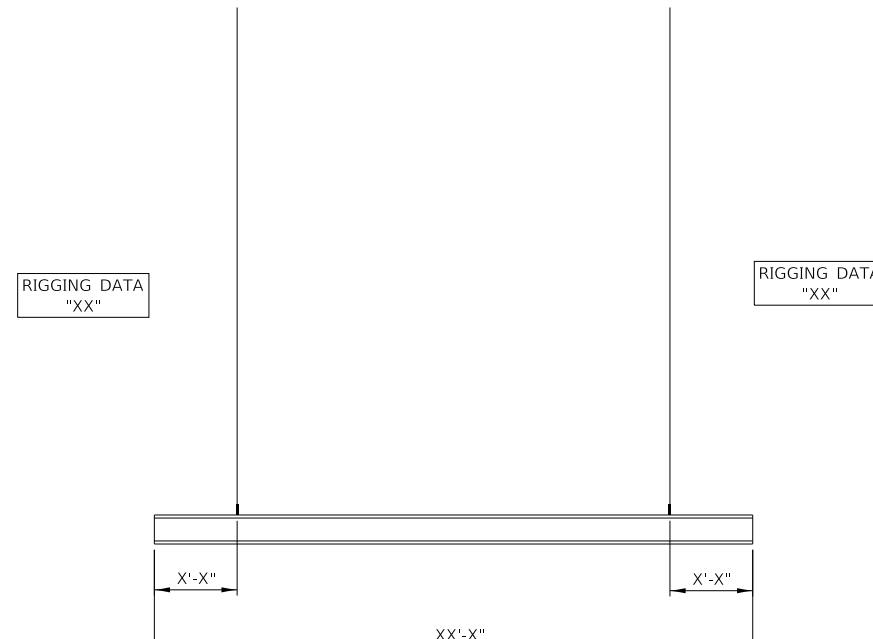

CALCULATED RIGGING WEIGHT = XX LBS.

ELEVATION VIEW

RIGGING DETAILS
TWO CRANE

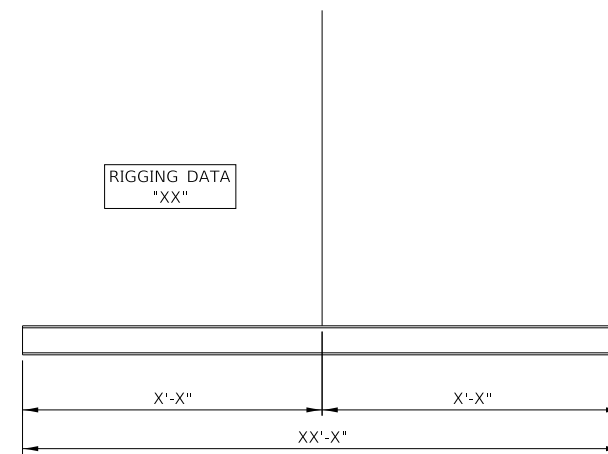

CALCULATED RIGGING WEIGHT = XX LBS.

ELEVATION VIEW

RIGGING DETAILS
SINGLE CRANE

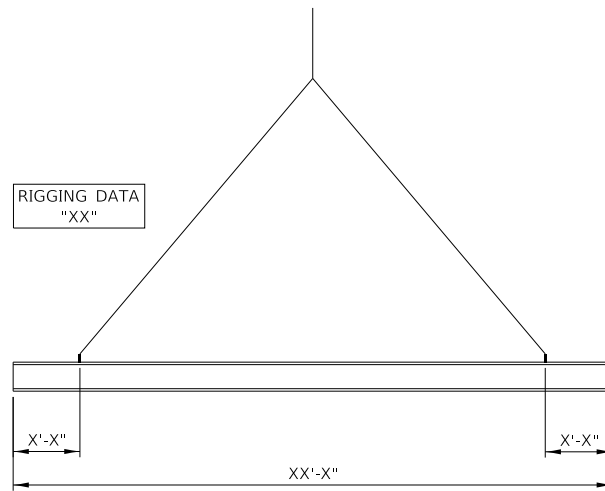

CALCULATED RIGGING WEIGHT = XX LBS.

ELEVATION VIEW

RIGGING DETAILS
SINGLE CRANE

NOTE TO DESIGNER

THIS BASE SHEET SHOWS TYPICAL CONSTRUCTION BUT IT IS **NOT** A STANDARD DRAWING. IT REQUIRES COMPLETION BY THE DESIGNER PRIOR TO INSERTION INTO A CONTRACT. MICROSTATION FILES AND THE "CADD STANDARDS MANUAL" ARE AVAILABLE ON THE ILLINOIS TOLLWAY WEBSITE. THE DESIGNER SHALL ACCEPT THE RESPONSIBILITY OF THE DESIGN OF THIS SHEET UPON ITS COMPLETION AND INSERTION INTO A CONTRACT. ALL "NOTE TO DESIGNER" BOXES SHALL BE REMOVED BY THE DESIGNER PRIOR TO INSERTION OF THE SHEET INTO THE PLAN SET.

NOTE TO DESIGNER

"XX" DESIGNATES DIMENSION VALUES OR INPUT DATA TO BE PROVIDED ON SUBMITTED DRAWING.

SPECIFY CENTER OF GRAVITY OF LOAD.



ERECTION PLAN - STEEL

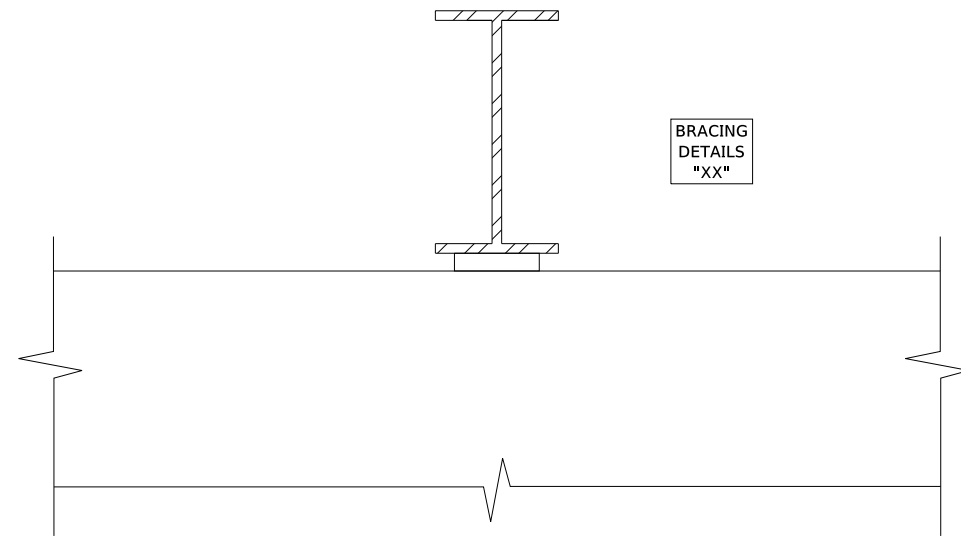

TEMPORARY ERECTION
BRACING DETAIL

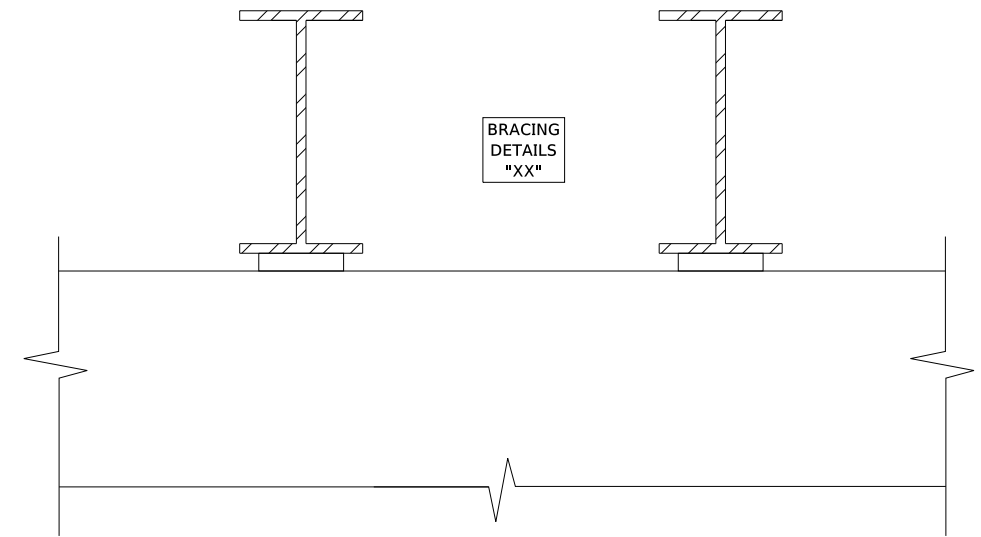

TEMPORARY ERECTION
BRACING DETAIL

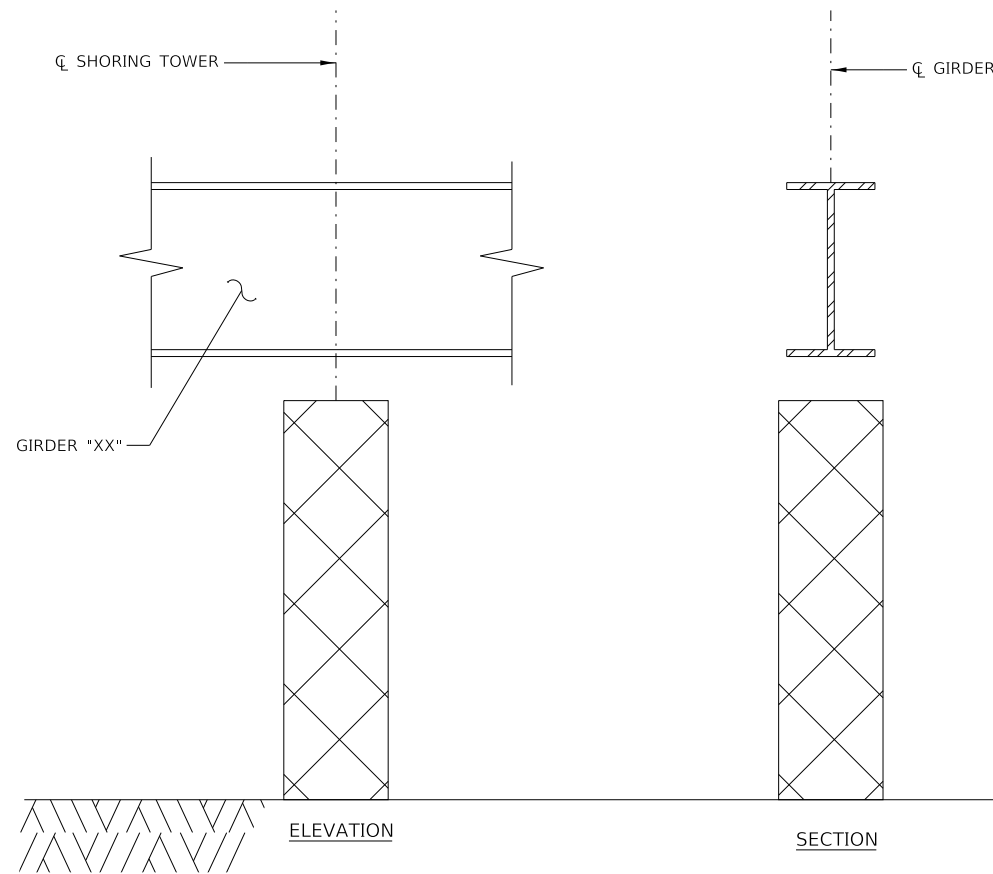

TEMPORARY SHORING DETAILS

NOTE TO DESIGNER

THIS BASE SHEET SHOWS TYPICAL CONSTRUCTION BUT IT IS **NOT** A STANDARD DRAWING. IT REQUIRES COMPLETION BY THE DESIGNER PRIOR TO INSERTION INTO A CONTRACT. MICROSTATION FILES AND THE "CADD STANDARDS MANUAL" ARE AVAILABLE ON THE ILLINOIS TOLLWAY WEBSITE. THE DESIGNER SHALL ACCEPT THE RESPONSIBILITY OF THE DESIGN OF THIS SHEET UPON ITS COMPLETION AND INSERTION INTO A CONTRACT. ALL "NOTE TO DESIGNER" BOXES SHALL BE REMOVED BY THE DESIGNER PRIOR TO INSERTION OF THE SHEET INTO THE PLAN SET.

NOTE TO DESIGNER

"XX" DESIGNATES DIMENSION VALUES OR INPUT DATA TO BE PROVIDED ON SUBMITTED DRAWING.

PROPOSED TEMPORARY SHORING AND DETAILS SHALL BE SHOWN.



ERECTION PLAN - STEEL

NOTE TO DESIGNER
 THIS SHEET IS NOT TO SCALE. DESIGNER TO DETERMINE APPROPRIATE SCALE ON GP&E SHEET TO ACCURATELY REPRESENT REQUIRED INFORMATION.

NOTE TO DESIGNER
 ALL SIGNS MOUNTED TO NAW SHALL BE SHOWN ON GP&E IN ACCORDANCE WITH LATEST ILLINOIS TOLLWAY DETAIL FOR NOISE ABATEMENT WALL MOUNTED SIGN SUPPORT.

NOTE TO DESIGNER
 THE BASE SHEET SHOWS TYPICAL CONSTRUCTION BUT IS NOT A STANDARD DRAWING. IT REQUIRES COMPLETION BY THE DSE PRIOR TO INSERTION INTO A CONTRACT. THE DSE SHALL ACCEPT RESPONSIBILITY OF THE DESIGN UPON ITS COMPLETION AND INSERTION INTO A CONTRACT.

THIS BASE SHEET REPRESENTS THE TYPICAL DETAILS FOR STRUCTURE MOUNTED, NOISE ABATEMENT WALLS. THE DSE IS RESPONSIBLE FOR COMPLETING THE TABLES AND INCLUDE IN THEIR CONTRACT PLANS. IF ANY OF THE DESIGN PARAMETERS IN THE ILLINOIS TOLLWAY STANDARD ARE EXCEEDED, THE DSE WILL BE RESPONSIBLE FOR DESIGN CALCULATIONS AND DETAILS FOR THOSE COMPONENTS.

THE PLAN AND ELEVATION ON THIS COVER SHEET REPRESENTS ADDITIONAL INFORMATION TO SHOW ON THE GP&E SHEET. THE GP&E SHEET AND REMAINING NAW PLANS SHALL BE IN ACCORDANCE WITH ILLINOIS TOLLWAY STRUCTURE DESIGN MANUAL ARTICLES 6.2.5 AND 23.3.

NOTE TO DESIGNER
 THE COVER SHEET IS FOR INFORMATION ONLY AND SHOULD NOT BE INCLUDED IN THE DSE'S SET OF PLANS.

NOTE TO DESIGNER
 INCLUDE ACOUSTICAL PROFILE FOR INFORMATION ONLY.

NOTE TO DESIGNER
 USE SPECIALTY PANEL AND POST SPACING AT ENDS OF WALL OR UNIQUE LOCATIONS SUCH AS INTERIOR OR EXPANSION JOINT CONFLICTS TO ACCOMMODATE TYPICAL 11'-8" POST SPACING ALONG THE MAJORITY OF THE LENGTH OF WALL. POST SPACING SHOULD NOT EXCEED LIMITS WITHIN THE ILLINOIS TOLLWAY STANDARD. IF LIMITS ARE EXCEEDED, DSE TO DESIGN AND DETAIL ALL COMPONENTS.

NOTE TO DESIGNER
 ELEVATIONS SHOULD ACCOUNT FOR 1/4" GAP BETWEEN PANELS.

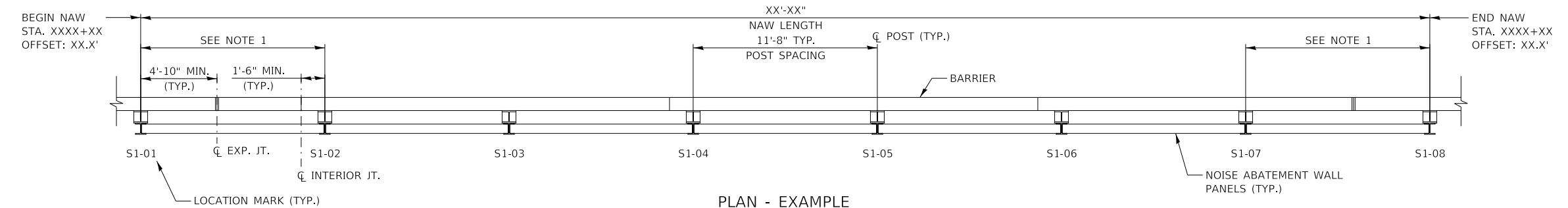

PLAN - EXAMPLE

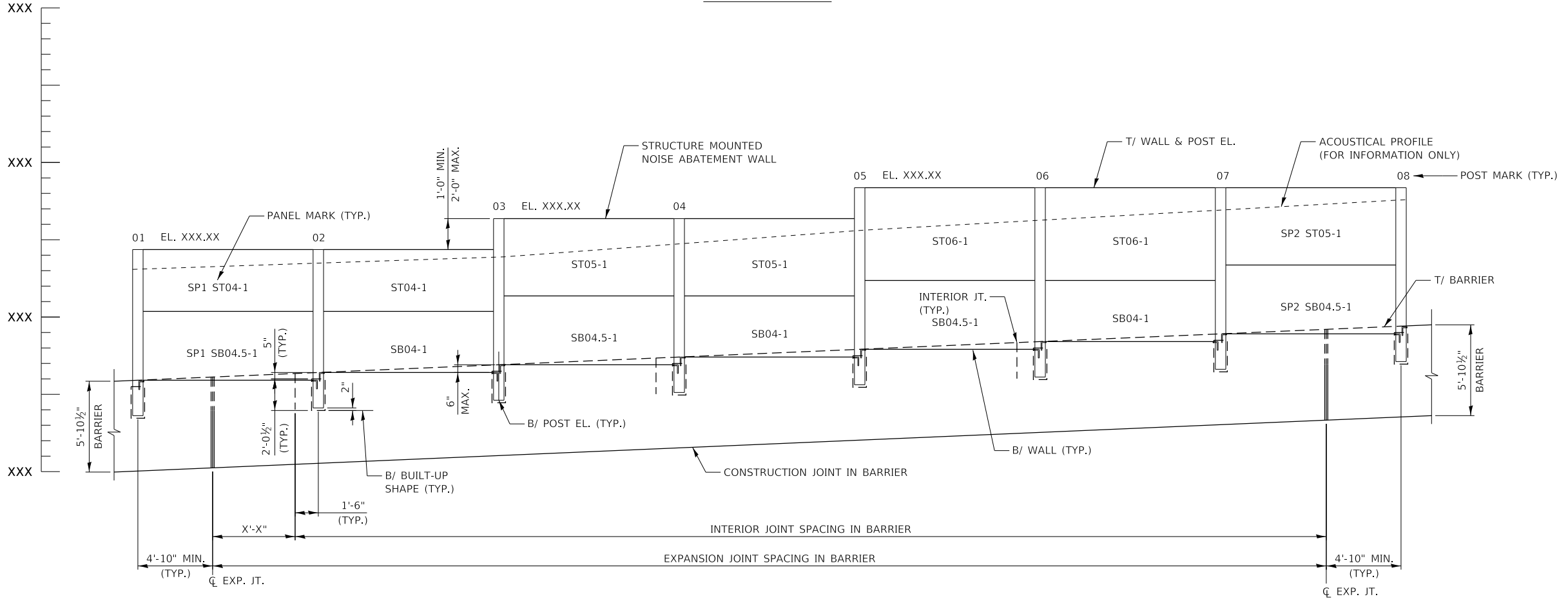

ELEVATION - EXAMPLE



STRUCTURE MOUNTED NOISE ABATEMENT WALL COVER SHEET

VERSION: 2024-03	STANDARD: M-BRG-529	SHEET: 1 OF 3
---------------------	------------------------	------------------

STRUCTURE MOUNTED PANEL SCHEDULE				
PANEL MARK	PANEL HEIGHT	PANEL WIDTH	TOTAL PANEL THICKNESS	NUMBER OF PANELS
*SB04-1	4'-0"	11'-6"	5½"	X
*SB04.5-1	4'-6"	11'-6"	5½"	X
SC04-1	4'-0"	11'-6"	5½"	X
ST04-1	4'-0"	11'-6"	5½"	X
ST05-1	5'-0"	11'-6"	5½"	X
ST06-1	6'-0"	11'-6"	5½"	X
ST07-1	7'-0"	11'-6"	5½"	X
ST08-1	8'-0"	11'-6"	5½"	X
STF04-1	4'-0"	11'-6"	5½"	X
STF04.5-1	4'-6"	11'-6"	5½"	X
STF05-1	5'-0"	11'-6"	5½"	X
STF05.5-1	5'-6"	11'-6"	5½"	X
STF06-1	6'-0"	11'-6"	5½"	X
STF06.5-1	6'-6"	11'-6"	5½"	X
STF07-1	7'-0"	11'-6"	5½"	X
STF07.5-1	7'-6"	11'-6"	5½"	X
STF08-1	8'-0"	11'-6"	5½"	X
*SPX SB04-1	4'-0"	XX'-X"	5½"	X
*SPX SB04.5-1	4'-6"	XX'-X"	5½"	X
SPX SC04-1	4'-0"	XX'-X"	5½"	X
SPX ST04-1	4'-0"	XX'-X"	5½"	X
SPX ST05-1	5'-0"	XX'-X"	5½"	X
SPX ST06-1	6'-0"	XX'-X"	5½"	X
SPX ST07-1	7'-0"	XX'-X"	5½"	X
SPX ST08-1	8'-0"	XX'-X"	5½"	X
SPX STF04-1	4'-0"	XX'-X"	5½"	X
SPX STF04.5-1	4'-6"	XX'-X"	5½"	X
SPX STF05-1	5'-0"	XX'-X"	5½"	X
SPX STF05.5-1	5'-6"	XX'-X"	5½"	X
SPX STF06-1	6'-0"	XX'-X"	5½"	X
SPX STF06.5-1	6'-6"	XX'-X"	5½"	X
SPX STF07-1	7'-0"	XX'-X"	5½"	X
SPX STF07.5-1	7'-6"	XX'-X"	5½"	X
SPX STF08-1	8'-0"	XX'-X"	5½"	X

NOTE:
1. WORK THIS SHEET WITH ILLINOIS TOLLWAY STANDARD G12.

*CONTRACTOR MAY INCREASE BOTTOM PANEL HEIGHTS AND USE UP TO AN 8 FT (NON-STANDARD) MAXIMUM HEIGHT PANEL. THE ADJACENT TOP PANEL MAY ALSO BE ADJUSTED, PROVIDED STANDARD PANEL HEIGHTS AS SHOWN IN STANDARD G12 ARE USED. CONTRACTOR SHALL SUBMIT SHOP DRAWINGS TO THE ENGINEER FOR REVIEW PRIOR TO INSTALLATION.

DESIGN SPECIFICATIONS

ILLINOIS TOLLWAY STRUCTURE DESIGN MANUAL,
DATED XXXXXXXXXXXXXXXX.

ILLINOIS TOLLWAY GEOTECHNICAL MANUAL,
DATED XXXXXXXXXXXXXXXX.

AASHTO LRFD BRIDGE DESIGN SPECIFICATIONS,
DATED XXXXXXXXXXXXXXXX.

CONSTRUCTION SPECIFICATIONS

ILLINOIS DEPARTMENT OF TRANSPORTATION LATEST GUIDE
BRIDGE SPECIAL PROVISIONS (GBSPs)

ILLINOIS TOLLWAY SUPPLEMENTAL SPECIFICATIONS TO THE
ILLINOIS DEPARTMENT OF TRANSPORTATION STANDARD
SPECIFICATIONS FOR ROAD AND BRIDGE CONSTRUCTION,
DATED XXXXXXXXXXXXXXXX.

ILLINOIS DEPARTMENT OF TRANSPORTATION SUPPLEMENTAL
SPECIFICATIONS AND RECURRING SPECIAL PROVISIONS,
DATED XXXXXXXXXXXXXXXX.

ILLINOIS DEPARTMENT OF TRANSPORTATION STANDARD
SPECIFICATIONS FOR ROAD AND BRIDGE CONSTRUCTION,
DATED XXXXXXXXXXXXXXXX.

GENERAL NOTES

- CONTRACTOR SHALL NOT SCALE DIMENSIONS FROM THE CONTRACT PLANS FOR CONSTRUCTION PURPOSES. SCALES SHOWN ARE FOR INFORMATION ONLY.
- NO CONSTRUCTION JOINTS EXCEPT THOSE SHOWN ON THE PLANS SHALL BE ALLOWED UNLESS APPROVED BY THE ENGINEER.
- THE CONTRACTOR MAY REQUEST COPIES OF EXISTING CONSTRUCTION PLANS THAT ARE CURRENTLY ON FILE WITH THE ILLINOIS TOLLWAY. THE REQUEST SHALL BE IN WRITING WITH THE UNDERSTANDING THAT ANY REPRODUCTION COST WILL BE AT THE CONTRACTOR'S EXPENSE AT NO ADDITIONAL COST TO THE ILLINOIS TOLLWAY.
- NO CONCRETE CUTTING SHALL BE PERMITTED UNTIL THE CUTTING LIMITS HAVE BEEN OUTLINED BY THE CONTRACTOR AND APPROVED BY THE ENGINEER.
- IT SHALL BE THE CONTRACTOR'S RESPONSIBILITY TO VERIFY THE LOCATION OF ALL UTILITIES PRIOR TO STARTING CONSTRUCTION. CONTACT J.U.L.I.E., 800-892-0123.
- IT SHALL BE THE CONTRACTOR'S RESPONSIBILITY TO VERIFY THE LOCATION OF ALL FIBER OPTIC UTILITIES PRIOR TO STARTING CONSTRUCTION. THE CONTRACTOR SHALL INITIATE THE LOCATION PROCESS FOR THE FIBER OPTIC CABLE BY COMPLETING A "REQUEST ILLINOIS TOLLWAY UTILITIES LOCATE" FORM ONLINE AT THE ILLINOIS TOLLWAY WEBSITE UNDER "DOING BUSINESS" AT LEAST FOUR (4) BUSINESS DAYS PRIOR TO STARTING ANY UNDERGROUND OPERATIONS, EXCAVATIONS OR DIGGING OF ANY TYPE IN THE GENERAL AREA OF THE FIBER OPTIC CABLE."
- WHENEVER ANY MATERIAL IS DEPOSITED INTO A DRAINAGE SYSTEM OR DRAINAGE STRUCTURES, THE DEPOSITED MATERIAL SHALL BE REMOVED AT THE CLOSE OF EACH WORKING DAY. AT THE CONCLUSION OF CONSTRUCTION OPERATIONS, ALL DRAINAGE SYSTEMS AND STRUCTURES SHALL BE FREE FROM DIRT AND DEBRIS DEPOSITED DURING THE VARIOUS CONSTRUCTION OPERATIONS.

NOTE TO DESIGNER
THIS BASE SHEET SHOWS TYPICAL CONSTRUCTION BUT IT IS NOT A STANDARD DRAWING. IT REQUIRES COMPLETION BY THE DESIGNER PRIOR TO INSERTION INTO A CONTRACT. MICROSTATION FILES AND THE "CADD STANDARDS MANUAL" ARE AVAILABLE ON THE ILLINOIS TOLLWAY WEBSITE. THE DESIGNER SHALL ACCEPT THE RESPONSIBILITY OF THE DESIGN OF THIS SHEET UPON ITS COMPLETION AND INSERTION INTO A CONTRACT. ALL "NOTE TO DESIGNER" BOXES SHALL BE REMOVED BY THE DESIGNER PRIOR TO INSERTION OF THE SHEET INTO THE PLAN SET.

NOTE TO DESIGNER
DESIGNER TO COMPLETE TABLES.

NOTE TO DESIGNER
FOR CTS PROJECTS UTILIZING BUMP-OUTS, SEE M-BRG-531 SHEET 3 OF 4.

NOTE TO DESIGNER
PANEL MARK SHOULD BE SHOWN ON THE ELEVATION VIEW ON THE GP&E

NOTE TO DESIGNER
FOR PANELS SPANNING BRIDGE EXPANSION JOINTS, DETAILS FROM M-BRG-530 SHALL BE INCLUDED AND NOTE ADDED IDENTIFYING THE EXPANSION PANEL

NOTE TO DESIGNER
REPLACE XXXXXXXXXXXXXXXX WITH THE LATEST DATE

NAW TYPE

- STF = STRUCTURE MOUNTED FULL HEIGHT PANEL
- ST = STRUCTURE MOUNTED TOP PANEL
- SC = STRUCTURE MOUNTED CENTER PANEL
- SB = STRUCTURE MOUNTED BOTTOM PANEL
- SP = SPECIALTY PANEL

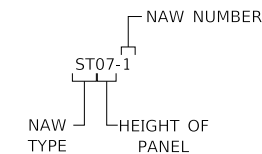

TYPICAL PANEL NAMING CONVENTION

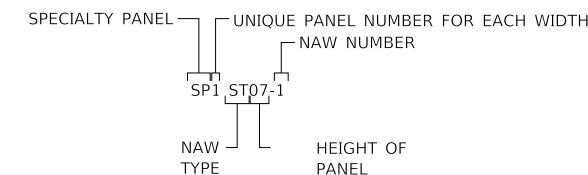

SPECIALTY PANEL NAMING CONVENTION

LIST OF ABBREVIATIONS

AASHTO	AMERICAN ASSOCIATION OF STATE HIGHWAY AND TRANSPORTATION OFFICIALS
ABUT.	ABUTMENT
BK.	BACK
B.F.	BACK FACE
℄	BASELINE
BRG.	BEARING
BOTT.	BOTTOM
B/	BOTTOM OF
BM	BRIDGE MOUNTED
℄	CENTERLINE
CL.	CLEARANCE
COL.	COLUMN
CONC.	CONCRETE
CGM	CRASHWORTHY GROUND MOUNTED
E.E.	EACH END
E.	EAST
EB	EASTBOUND
ELEV.	ELEVATION
EQ.	EQUAL
EXIST.	EXISTING
EXP.	EXPANSION
F.F.	FRONT FACE
JT.	JOINT
LOC.	LOCATION
MAX.	MAXIMUM
MIN.	MINIMUM
NAW	NOISE ABATEMENT WALL
N.	NORTH
N.A.	NOT APPLICABLE
O.C.	ON CENTER
℄	PLATE
PVC	POINT OF VERTICAL CURVE
PVI	POINT OF VERTICAL INTERSECTION
PVT	POINT OF VERTICAL TANGENCY
PROP.	PROPOSED
SHLDR.	SHOULDER
S.	SOUTH
S.P.	SPECIAL PROVISION
SQ. FT.	SQUARE FOOT
SQ. YD.	SQUARE YARD
STA.	STATION
STRUCT	STRUCTURAL
S.M.	STRUCTURE MOUNTED
T/	TOP OF
TYP.	TYPICAL
U.N.O.	UNLESS NOTED OTHERWISE
WB	WESTBOUND
WF	WIDE FLANGE



STRUCTURE MOUNTED NOISE ABATEMENT WALL SCHEDULE

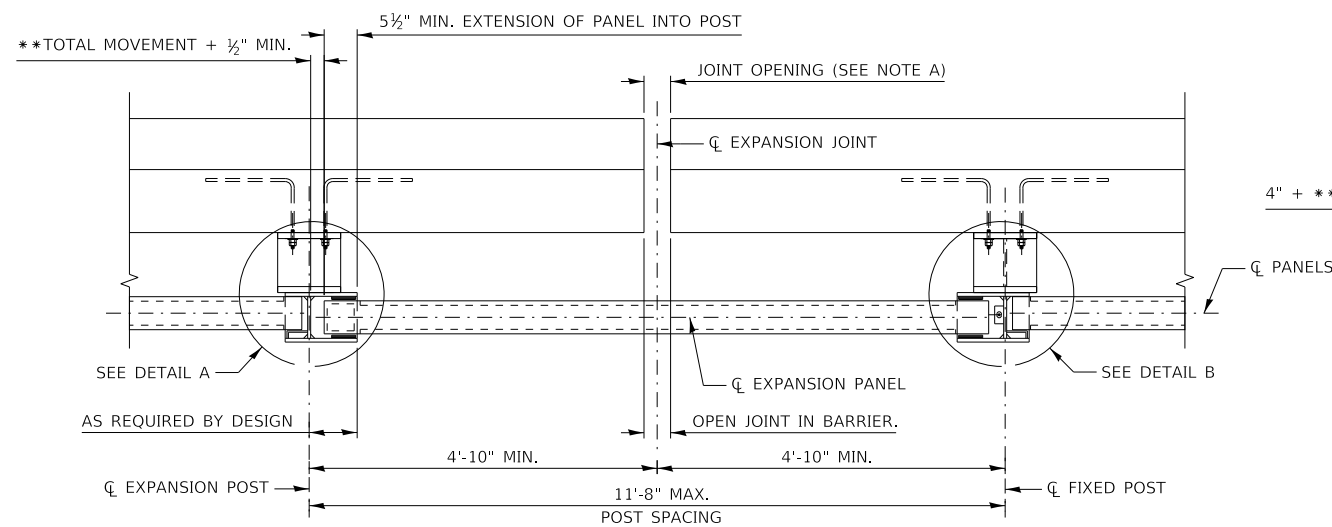

PLAN

NOTE A
JOINT OPENING AS REQUIRED FOR BRIDGE
EXPANSION AND CONTRACTION AT 50°F.

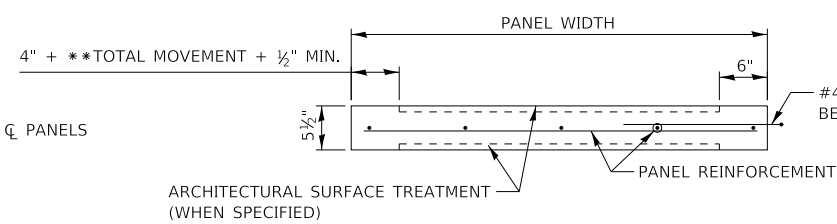

PRECAST CONCRETE EXPANSION PANEL

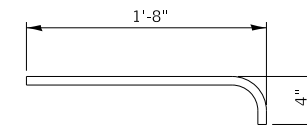

STEEL BENT BARS DETAIL

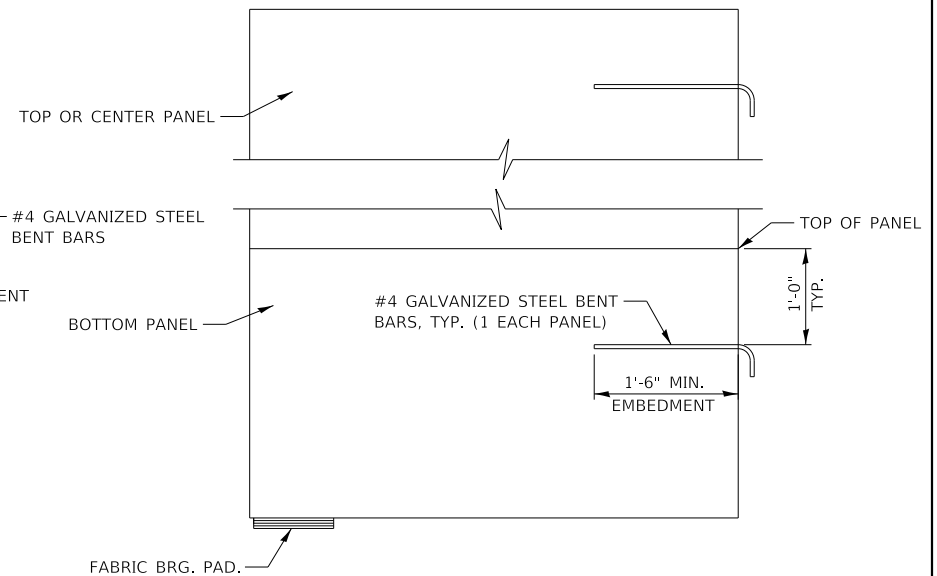

EXPANSION PANEL ELEVATION

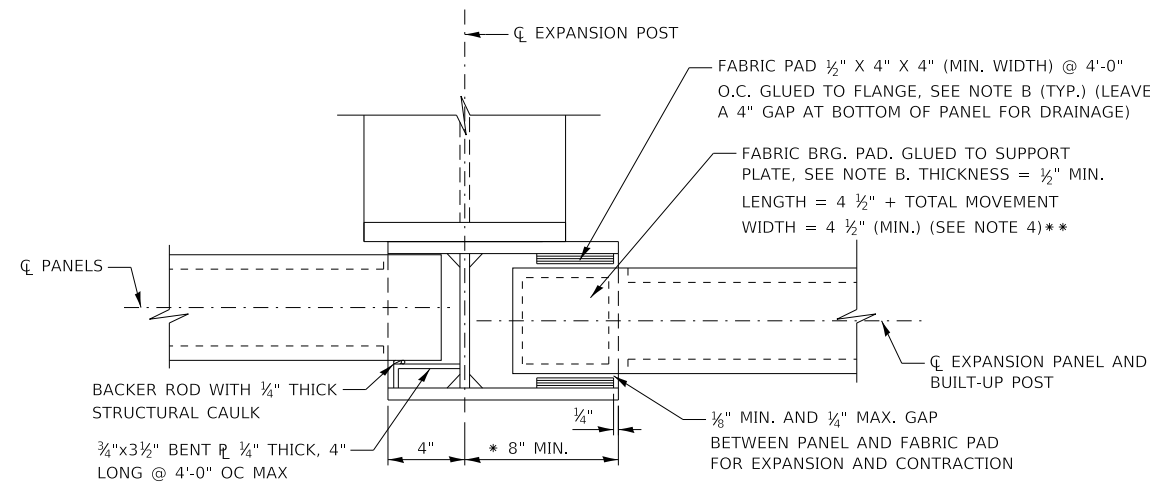

DETAIL A
(EXPANSION POST)

NOTE B
ADHESION OF THE PAD TO THE STEEL SHALL BE PER SECTION 1083.02 OF THE STANDARD SPECIFICATION.

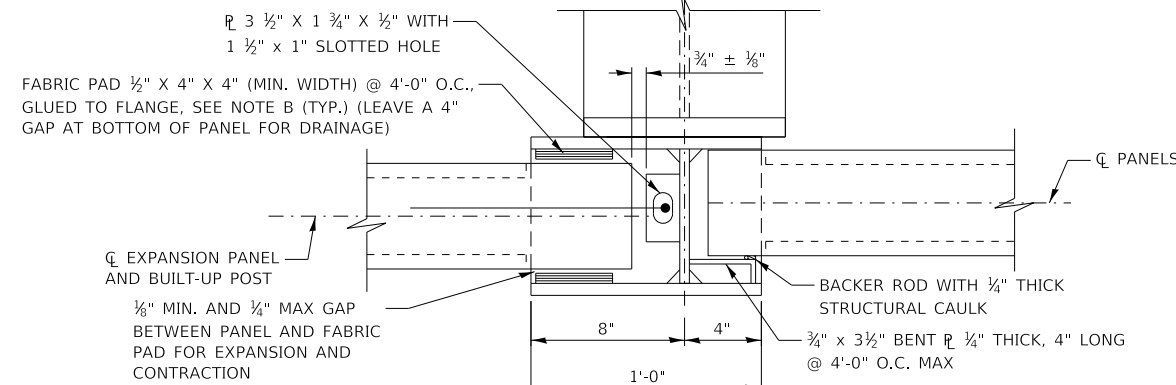

DETAIL B
(FIXED POST)

NOTE TO DESIGNER

THIS BASE SHEET SHOWS TYPICAL CONSTRUCTION BUT IT IS NOT A STANDARD DRAWING. IT REQUIRES COMPLETION BY THE DESIGNER PRIOR TO INSERTION INTO A CONTRACT. MICROSTATION FILES AND THE "CADD STANDARDS MANUAL" ARE AVAILABLE ON THE ILLINOIS TOLLWAY WEBSITE. THE DESIGNER SHALL ACCEPT THE RESPONSIBILITY OF THE DESIGN OF THIS SHEET UPON ITS COMPLETION AND INSERTION INTO A CONTRACT. ALL "NOTE TO DESIGNER" BOXES SHALL BE REMOVED BY THE DESIGNER PRIOR TO INSERTION OF THE SHEET INTO THE PLAN SET.

- NOTE TO DESIGNER
- THIS BASE SHEET SHALL BE USED WHEN THERE IS AN EXPANSION JOINT IN THE BRIDGE DECK AND PARAPET.
 - DESIGNER MUST INCLUDE ALL DETAILS REQUIRED ON THE CONTRACT DRAWINGS.
 - DESIGNER TO DETERMINE TOTAL MOVEMENT REQUIRED.
 - DESIGNER TO PROVIDE NEOPRENE BEARING SIZE AND PLATE WIDTH FOR THE BUILT-UP SECTION AT EXPANSION POST BASED ON THE JOINT OPENING AND MOVEMENT.
 - IF STRUCTURE MOUNTED SOUND BARRIER ENDS AT THE EXPANSION POST AND CONNECTS TO A GROUND MOUNTED BARRIER PROVIDE ADDITIONAL DETAILS AS REQUIRED IN ACCORDANCE WITH THESE STANDARDS.
- * MIN. SIZE SHOWN, PROVIDE SIZE REQUIRED PER DESIGN.
- ** TOTAL EXPANSION MOVEMENT FROM NORMAL TEMPERATURE OF 50°F AT THE EXPANSION JOINT IN THE BRIDGE DECK AND PARAPET.

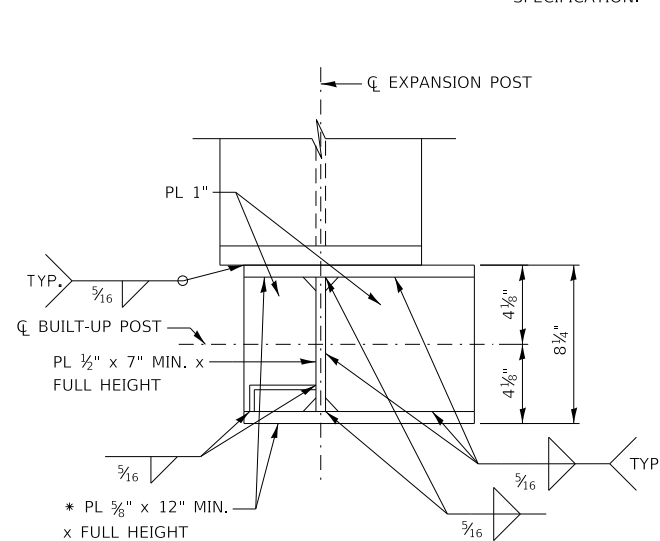

BUILT UP SHAPE
(AT EXPANSION POINT)

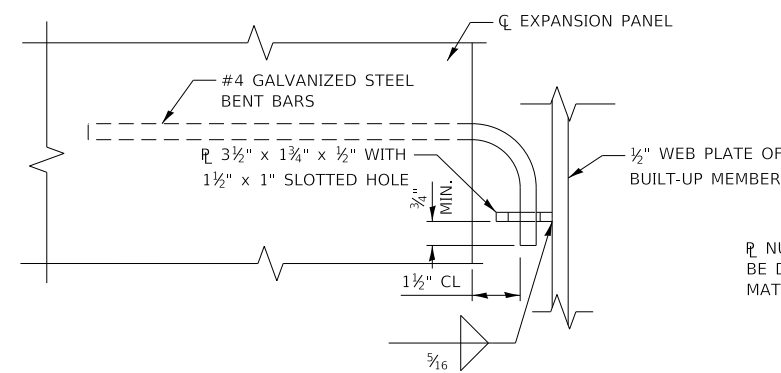

BARS LOCKING DETAIL
(SECTION THRU HOLE)

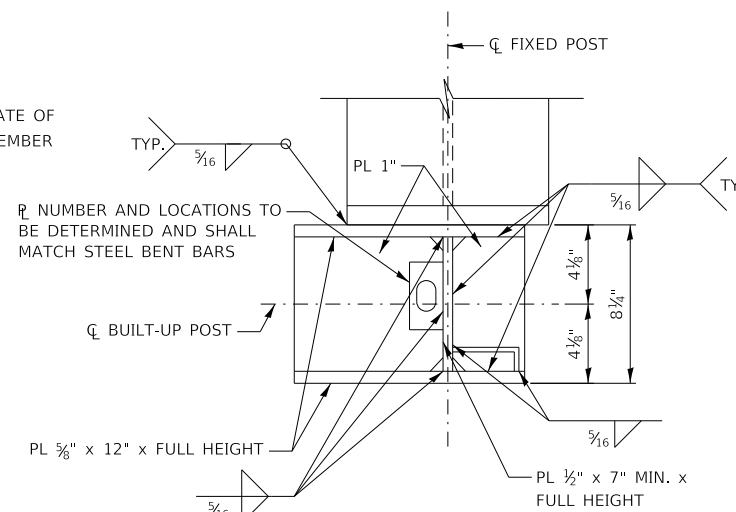

BUILT UP SHAPE
(AT FIXED POST)

NOTE TO DESIGNER

THIS SHEET IS NOT TO SCALE. DESIGNER TO DETERMINE APPROPRIATE SCALE ON GP&E SHEET TO ACCURATELY REPRESENT REQUIRED INFORMATION.

NOTE TO DESIGNER

ALL SIGNS MOUNTED TO NAW SHALL BE SHOWN ON GP&E IN ACCORDANCE WITH LATEST ILLINOIS TOLLWAY DETAIL FOR NOISE ABATEMENT WALL MOUNTED SIGN SUPPORT.

NOTE TO DESIGNER

THE BASE SHEET SHOWS TYPICAL CONSTRUCTION BUT IS NOT A STANDARD DRAWING. IT REQUIRES COMPLETION BY THE DSE PRIOR TO INSERTION INTO A CONTRACT. THE DSE SHALL ACCEPT RESPONSIBILITY OF THE DESIGN UPON ITS COMPLETION AND INSERTION INTO A CONTRACT.

THIS BASE SHEET REPRESENTS THE TYPICAL DETAILS FOR STRUCTURE MOUNTED, NOISE ABATEMENT WALLS. THE DSE IS RESPONSIBLE FOR COMPLETING THE TABLES AND INCLUDE IN THEIR CONTRACT PLANS. IF ANY OF THE DESIGN PARAMETERS IN THE ILLINOIS TOLLWAY STANDARD ARE EXCEEDED, THE DSE WILL BE RESPONSIBLE FOR DESIGN CALCULATIONS AND DETAILS FOR THOSE COMPONENTS.

THE PLAN AND ELEVATION ON THIS COVER SHEET REPRESENTS ADDITIONAL INFORMATION TO SHOW ON THE GP&E SHEET. THE GP&E SHEET AND REMAINING NAW PLANS SHALL BE IN ACCORDANCE WITH ILLINOIS TOLLWAY STRUCTURE DESIGN MANUAL ARTICLES 6.2.5 AND 23.3.

NOTE TO DESIGNER

THE COVER SHEET IS FOR INFORMATION ONLY AND SHOULD NOT BE INCLUDED IN THE DSE'S SET OF PLANS.

NOTE TO DESIGNER

INCLUDE ACOUSTICAL PROFILE FOR INFORMATION ONLY.

NOTE TO DESIGNER

ELEVATIONS SHOULD ACCOUNT FOR 1/4" GAP BETWEEN PANELS.

NOTE TO DESIGNER

NOTE:

1. USE SPECIALTY PANEL AND POST SPACING AT ENDS OF WALL OR UNIQUE LOCATIONS SUCH AS INTERIOR OR EXPANSION JOINT CONFLICTS TO ACCOMMODATE TYPICAL 11'-8" POST SPACING ALONG THE MAJORITY OF THE LENGTH OF WALL. POST SPACING SHOULD NOT EXCEED LIMITS WITHIN THE ILLINOIS TOLLWAY STANDARD. IF LIMITS ARE EXCEEDED, DSE TO DESIGN AND DETAIL ALL COMPONENTS. THE "SPX" DESIGNATION FOR SPECIALTY PANELS SHOULD BE USED FOR ALL PANELS WITHIN THAT BAY WITH THE SAME WIDTH.

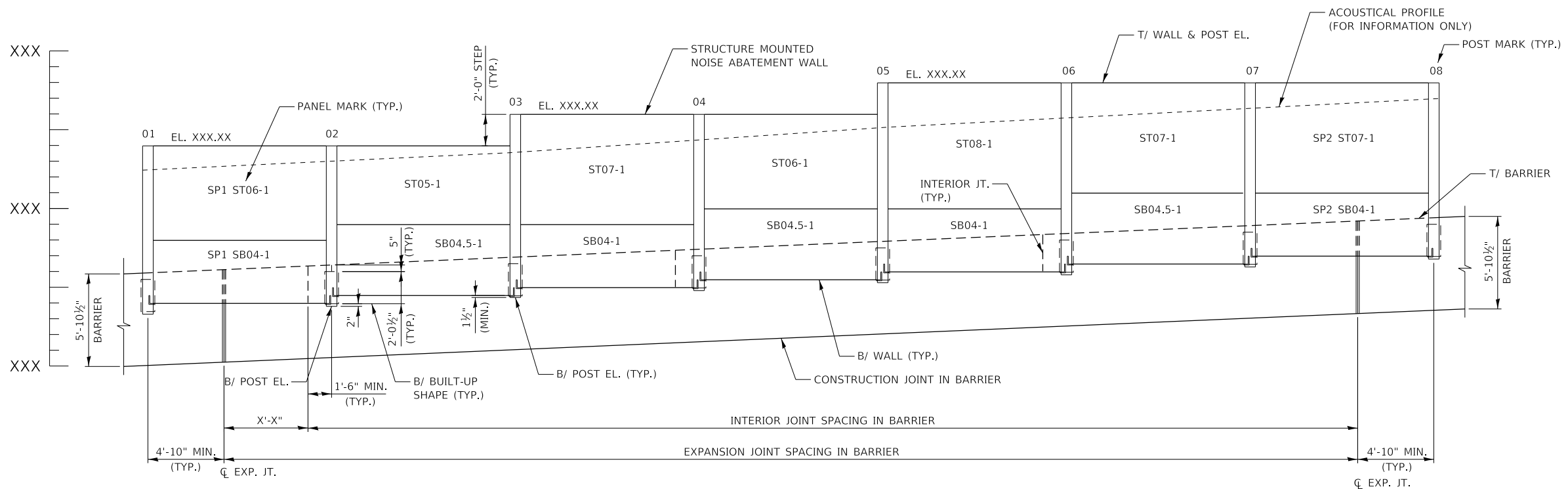
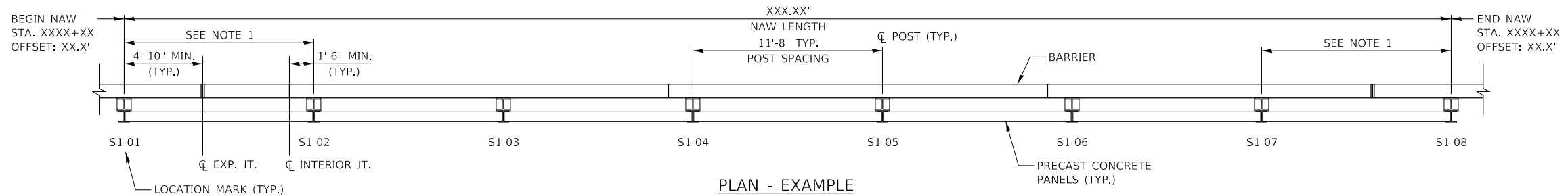

**CENTRAL TRI-STATE
STRUCTURE MOUNTED NOISE
ABATEMENT WALL COVER
SHEET**

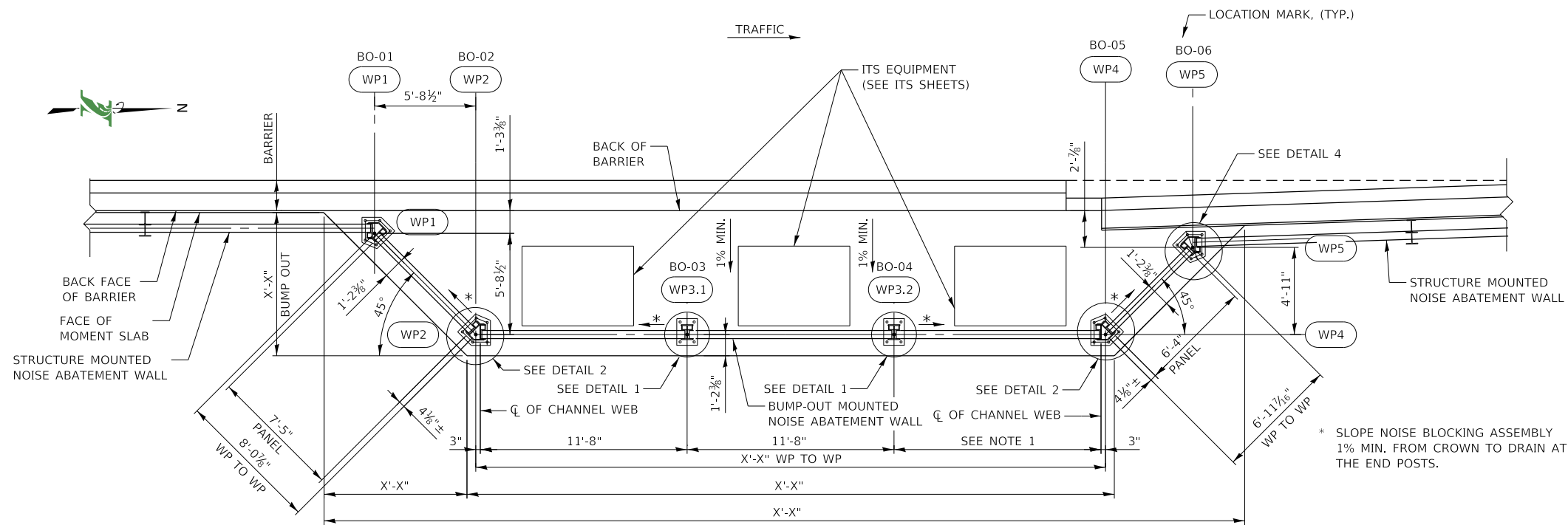

PLAN - EXAMPLE

NOTE TO DESIGNER
 THE COVER SHEET IS FOR INFORMATION ONLY AND SHOULD NOT BE INCLUDED IN THE DSE'S SET OF PLANS.

NOTE TO DESIGNER
 BUMP-OUT MOUNTED NAW DETAILS MAY BE USED WITH SYSTEM WIDE STRUCTURE MOUNTED NAW DETAILS SHOWN IN STANDARD G12 AND M-BRG-529. DSE TO UPDATE ACCORDINGLY FOR SYSTEM WIDE GEOMETRY.

NOTE TO DESIGNER
 THIS SHEET IS NOT TO SCALE. DESIGNER TO DETERMINE APPROPRIATE SCALE ON GP&E SHEET TO ACCURATELY REPRESENT REQUIRED INFORMATION.

NOTE TO DESIGNER
NOTE:
 1. USE SPECIALTY PANEL AND POST SPACING AT END OF WALL TO ACCOMMODATE TYPICAL 11'-8" POST SPACING ALONG THE STRAIGHT LENGTH OF WALL. POST SPACING SHOULD NOT EXCEED LIMITS WITHIN THE ILLINOIS TOLLWAY STANDARD. IF LIMITS ARE EXCEEDED, DSE TO DESIGN AND DETAIL ALL COMPONENTS. THE "SPX" DESIGNATION FOR SPECIALTY PANELS SHOULD BE USED FOR ALL PANELS WITHIN BAY WITH THE SAME WIDTH.

NOTE TO DESIGNER
 THE BASE SHEET SHOWS TYPICAL CONSTRUCTION BUT IS NOT A STANDARD DRAWING. IT REQUIRES COMPLETION BY THE DSE PRIOR TO INSERTION INTO A CONTRACT. THE DSE SHALL ACCEPT RESPONSIBILITY OF THE DESIGN UPON ITS COMPLETION AND INSERTION INTO A CONTRACT.
 THIS BASE SHEET REPRESENTS THE TYPICAL DETAILS FOR BUMP-OUT MOUNTED, NOISE ABATEMENT WALLS. THE DSE IS RESPONSIBLE FOR COMPLETING THE TABLES AND INCLUDING THEM IN THEIR CONTRACT PLANS. IF ANY OF THE DESIGN PARAMETERS IN THE ILLINOIS TOLLWAY STANDARD ARE EXCEEDED, THE DSE WILL BE RESPONSIBLE FOR DESIGN CALCULATIONS AND DETAILS FOR THOSE COMPONENTS.
 THE PLAN AND ELEVATION ON THIS COVER SHEET REPRESENTS ADDITIONAL INFORMATION TO SHOW ON THE GP&E SHEET. THE GP&E SHEET AND REMAINING NAW PLANS SHALL BE IN ACCORDANCE WITH ILLINOIS TOLLWAY STRUCTURE DESIGN MANUAL ARTICLES 6.2.5 AND 23.3.

NOTE:
 SEE STANDARD G14 FOR DETAIL 1 AND DETAIL 2.

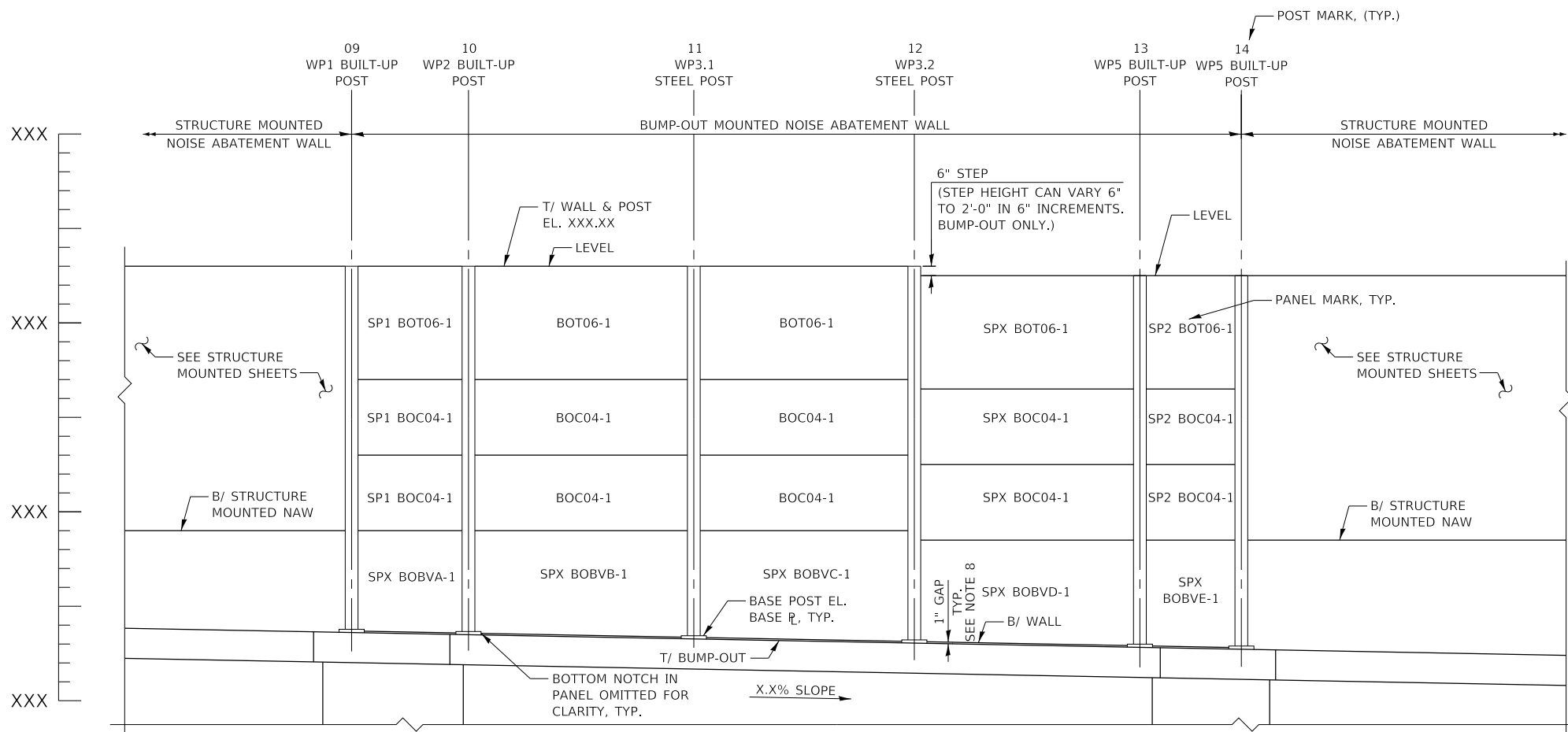

ELEVATION - EXAMPLE



**CENTRAL TRI-STATE
 BUMP-OUT MOUNTED NOISE
 ABATEMENT WALL COVER
 SHEET**

STRUCTURE MOUNTED PANEL SCHEDULE				
PANEL MARK	PANEL HEIGHT	PANEL WIDTH	TOTAL PANEL THICKNESS	NUMBER OF PANELS
***SB04-1	4'-0"	11'-6"	5 1/2"	X
***SB04.5-1	4'-6"	11'-6"	5 1/2"	X
SC04-1	4'-0"	11'-6"	5 1/2"	X
ST04-1	4'-0"	11'-6"	5 1/2"	X
ST05-1	5'-0"	11'-6"	5 1/2"	X
ST06-1	6'-0"	11'-6"	5 1/2"	X
ST07-1	7'-0"	11'-6"	5 1/2"	X
ST08-1	8'-0"	11'-6"	5 1/2"	X
STF04-1	4'-0"	11'-6"	5 1/2"	X
STF04.5-1	4'-6"	11'-6"	5 1/2"	X
STF05-1	5'-0"	11'-6"	5 1/2"	X
STF05.5-1	5'-6"	11'-6"	5 1/2"	X
STF06-1	6'-0"	11'-6"	5 1/2"	X
STF06.5-1	6'-6"	11'-6"	5 1/2"	X
STF07-1	7'-0"	11'-6"	5 1/2"	X
STF07.5-1	7'-6"	11'-6"	5 1/2"	X
STF08-1	8'-0"	11'-6"	5 1/2"	X
***SPX SB04-1	4'-0"	X'-X"	5 1/2"	X
***SPX SB04.5-1	4'-6"	X'-X"	5 1/2"	X
SPX SC04-1	4'-0"	X'-X"	5 1/2"	X
SPX ST04-1	4'-0"	X'-X"	5 1/2"	X
SPX ST05-1	5'-0"	X'-X"	5 1/2"	X
SPX ST06-1	6'-0"	X'-X"	5 1/2"	X
SPX ST07-1	7'-0"	X'-X"	5 1/2"	X
SPX ST08-1	8'-0"	X'-X"	5 1/2"	X
SPX STF04-1	4'-0"	X'-X"	5 1/2"	X
SPX STF04.5-1	4'-6"	X'-X"	5 1/2"	X
SPX STF05-1	5'-0"	X'-X"	5 1/2"	X
SPX STF05.5-1	5'-6"	X'-X"	5 1/2"	X
SPX STF06-1	6'-0"	X'-X"	5 1/2"	X
SPX STF06.5-1	6'-6"	X'-X"	5 1/2"	X
SPX STF07-1	7'-0"	X'-X"	5 1/2"	X
SPX STF07.5-1	7'-6"	X'-X"	5 1/2"	X
SPX STF08-1	8'-0"	X'-X"	5 1/2"	X

NOTE:

1. WORK THIS SHEET WITH ILLINOIS TOLLWAY STANDARD G12, G13 OR G14.

*** CONTRACTOR MAY INCREASE BOTTOM PANEL HEIGHTS AND USE UP TO AN 8FT (NON-STANDARD) MAXIMUM HEIGHT PANEL. THE ADJACENT TOP PANEL MAY ALSO BE ADJUSTED, PROVIDED STANDARD PANEL HEIGHTS AS SHOWN IN STANDARD G13 ARE USED. CONTRACTOR SHALL SUBMIT SHOP DRAWINGS TO THE ENGINEER FOR REVIEW PRIOR TO INSTALLATION.

DESIGN SPECIFICATIONS

ILLINOIS TOLLWAY STRUCTURE DESIGN MANUAL, DATED XXXXXXXXXXXXXXXX.

ILLINOIS TOLLWAY GEOTECHNICAL MANUAL, DATED XXXXXXXXXXXXXXXX.

AASHTO LRFD BRIDGE DESIGN SPECIFICATIONS, DATED XXXXXXXXXXXXXXXX.



CONSTRUCTION SPECIFICATIONS

ILLINOIS DEPARTMENT OF TRANSPORTATION LATEST GUIDE BRIDGE SPECIAL PROVISIONS (GBSPs)

ILLINOIS TOLLWAY SUPPLEMENTAL SPECIFICATIONS TO THE ILLINOIS DEPARTMENT OF TRANSPORTATION STANDARD SPECIFICATIONS FOR ROAD AND BRIDGE CONSTRUCTION, DATED XXXXXXXXXXXXXXXX.

ILLINOIS DEPARTMENT OF TRANSPORTATION SUPPLEMENTAL SPECIFICATIONS AND RECURRING SPECIAL PROVISIONS, DATED XXXXXXXXXXXXXXXX.

ILLINOIS DEPARTMENT OF TRANSPORTATION STANDARD SPECIFICATIONS FOR ROAD AND BRIDGE CONSTRUCTION, DATED XXXXXXXXXXXXXXXX.

BUMP-OUT STRUCTURE MOUNTED PANEL SCHEDULE				
PANEL MARK	PANEL HEIGHT	PANEL WIDTH	TOTAL PANEL THICKNESS	NUMBER OF PANELS
**BOC04-1	4'-0"	11'-6"	5 1/2"	X
**BOC04.5-1	4'-6"	11'-6"	5 1/2"	X
BOT04-1	4'-0"	11'-6"	5 1/2"	X
BOT05-1	5'-0"	11'-6"	5 1/2"	X
BOT06-1	6'-0"	11'-6"	5 1/2"	X
BOT07-1	7'-0"	11'-6"	5 1/2"	X
BOT08-1	8'-0"	11'-6"	5 1/2"	X
SP1 BOC04-1	4'-0"	7'-5"	5 1/2"	X
SP1 BOC04.5-1	4'-6"	7'-5"	5 1/2"	X
SP1 BOT04-1	4'-0"	7'-5"	5 1/2"	X
SP1 BOT05-1	5'-0"	7'-5"	5 1/2"	X
SP1 BOT06-1	6'-0"	7'-5"	5 1/2"	X
SP1 BOT07-1	7'-0"	7'-5"	5 1/2"	X
SP1 BOT08-1	8'-0"	7'-5"	5 1/2"	X
SP2 BOC04-1	4'-0"	6'-4"	5 1/2"	X
SP2 BOC04.5-1	4'-6"	6'-4"	5 1/2"	X
SP2 BOT04-1	4'-0"	6'-4"	5 1/2"	X
SP2 BOT05-1	5'-0"	6'-4"	5 1/2"	X
SP2 BOT06-1	6'-0"	6'-4"	5 1/2"	X
SP2 BOT07-1	7'-0"	6'-4"	5 1/2"	X
SP2 BOT08-1	8'-0"	6'-4"	5 1/2"	X
SPX BOC04-1	4'-0"	X'-X"	5 1/2"	X
SPX BOC04.5-1	4'-6"	X'-X"	5 1/2"	X
SPX BOT04-1	4'-0"	X'-X"	5 1/2"	X
SPX BOT05-1	5'-0"	X'-X"	5 1/2"	X
SPX BOT06-1	6'-0"	X'-X"	5 1/2"	X
SPX BOT07-1	7'-0"	X'-X"	5 1/2"	X
SPX BOT08-1	8'-0"	X'-X"	5 1/2"	X

NOTE:

1. WORK THIS SHEET WITH ILLINOIS TOLLWAY STANDARD.

* TO ACCOMMODATE VARYING SLAB GRADES, PANEL HEIGHTS WILL VARY TO FOLLOW SLOPE ON BUMP-OUT SLAB AND MAINTAIN A 1" GAP BETWEEN BOTTOM OF PANEL AND TOP OF SLAB.

** CONTRACTOR MAY INCREASE THE STANDARD CENTER PANEL HEIGHTS, MAXIMUM 8FT, TO MINIMIZE THE NUMBER OF JOINTS. THE ADJACENT TOP PANEL MAY ALSO BE ADJUSTED, PROVIDED STANDARD PANEL HEIGHTS AS SHOWN IN STANDARD G14 ARE USED. CONTRACTOR SHALL SUBMIT SHOP DRAWINGS TO THE ENGINEER FOR REVIEW PRIOR TO INSTALLATION.

GENERAL NOTES

- CONTRACTOR SHALL NOT SCALE DIMENSIONS FROM THE CONTRACT PLANS FOR CONSTRUCTION PURPOSES. SCALES SHOWN ARE FOR INFORMATION ONLY.
- NO CONSTRUCTION JOINTS EXCEPT THOSE SHOWN ON THE PLANS SHALL BE ALLOWED UNLESS APPROVED BY THE ENGINEER.
- THE CONTRACTOR MAY REQUEST COPIES OF EXISTING CONSTRUCTION PLANS THAT ARE CURRENTLY ON FILE WITH THE ILLINOIS TOLLWAY. THE REQUEST SHALL BE IN WRITING WITH THE UNDERSTANDING THAT ANY REPRODUCTION COST WILL BE AT THE CONTRACTOR'S EXPENSE AT NO ADDITIONAL COST TO THE ILLINOIS TOLLWAY.
- NO CONCRETE CUTTING SHALL BE PERMITTED UNTIL THE CUTTING LIMITS HAVE BEEN OUTLINED BY THE CONTRACTOR AND APPROVED BY THE ENGINEER.
- IT SHALL BE THE CONTRACTOR'S RESPONSIBILITY TO VERIFY THE LOCATION OF ALL UTILITIES PRIOR TO STARTING CONSTRUCTION. CONTACT J.U.L.I.E., 800-892-0123.
- IT SHALL BE THE CONTRACTOR'S RESPONSIBILITY TO VERIFY THE LOCATION OF ALL FIBER OPTIC UTILITIES PRIOR TO STARTING CONSTRUCTION. THE CONTRACTOR SHALL INITIATE THE LOCATION PROCESS FOR THE FIBER OPTIC CABLE BY COMPLETING A "REQUEST ILLINOIS TOLLWAY UTILITIES LOCATE" FORM ONLINE AT THE ILLINOIS TOLLWAY WEBSITE UNDER "DOING BUSINESS" AT LEAST FOUR (4) BUSINESS DAYS PRIOR TO STARTING ANY UNDERGROUND OPERATIONS, EXCAVATIONS OR DIGGING OF ANY TYPE IN THE GENERAL AREA OF THE FIBER OPTIC CABLE."
- WHENEVER ANY MATERIAL IS DEPOSITED INTO A DRAINAGE SYSTEM OR DRAINAGE STRUCTURES, THE DEPOSITED MATERIAL SHALL BE REMOVED AT THE CLOSE OF EACH WORKING DAY. AT THE CONCLUSION OF CONSTRUCTION OPERATIONS, ALL DRAINAGE SYSTEMS AND STRUCTURES SHALL BE FREE FROM DIRT AND DEBRIS DEPOSITED DURING THE VARIOUS CONSTRUCTION OPERATIONS.
- PROVIDE NOISE BLOCKING ASSEMBLY ALONG THE INSIDE PERIMETER OF THE WALL TO PREVENT SOUND THROUGH THE 1" GAP. SLOPE THE NOISE BLOCKING ASSEMBLY TO DRAIN AND STOP 3" SHORT OF THE END POSTS TO ALLOW WATER TO DRAIN.

BUMP-OUT STRUCTURE MOUNTED VARIABLE HEIGHT PANEL SCHEDULE							
PANEL MARK	PANEL HL	NOTCH HL	PANEL HR	NOTCH HR	PANEL WIDTH	TOTAL PANEL THICKNESS	NUMBER OF PANELS
SPX BOBVA-1	X'-X"	X"	X'-X"	X"	X'-X"	5 1/2"	X
SPX BOBVB-1	X'-X"	X"	X'-X"	X"	X'-X"	5 1/2"	X
SPX BOBVC-1	X'-X"	X"	X'-X"	X"	X'-X"	5 1/2"	X
SPX BOBVD-1	X'-X"	X"	X'-X"	X"	X'-X"	5 1/2"	X
SPX BOBVE-1	X'-X"	X"	X'-X"	X"	X'-X"	5 1/2"	X
SPX BOTFVA-1	X'-X"	X"	X'-X"	X"	X'-X"	5 1/2"	X
SPX BOTFVB-1	X'-X"	X"	X'-X"	X"	X'-X"	5 1/2"	X
SPX BOTFVC-1	X'-X"	X"	X'-X"	X"	X'-X"	5 1/2"	X
SPX BOTFVD-1	X'-X"	X"	X'-X"	X"	X'-X"	5 1/2"	X
SPX BOTFVE-1	X'-X"	X"	X'-X"	X"	X'-X"	5 1/2"	X

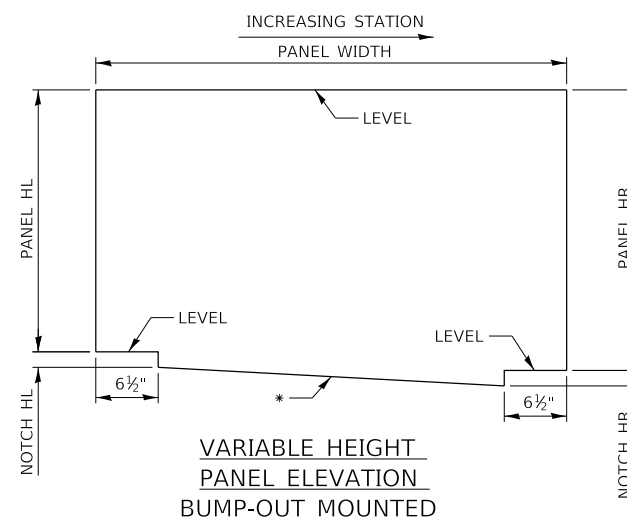

NAW TYPE

- STF = STRUCTURE MOUNTED FULL HEIGHT PANEL
- ST = STRUCTURE MOUNTED TOP PANEL
- SC = STRUCTURE MOUNTED CENTER PANEL
- SB = STRUCTURE MOUNTED BOTTOM PANEL
- BOTFV = BUMP-OUT STRUCTURE MOUNTED FULL HEIGHT PANEL (VARIABLE HEIGHT)
- BOT = BUMP-OUT STRUCTURE MOUNTED TOP PANEL
- BOC = BUMP-OUT STRUCTURE MOUNTED CENTER PANEL
- BOBV = BUMP-OUT STRUCTURE MOUNTED BOTTOM PANEL (VARIABLE HEIGHT)
- SP = SPECIALTY PANEL

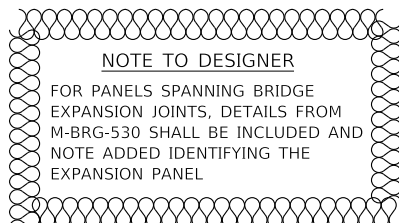
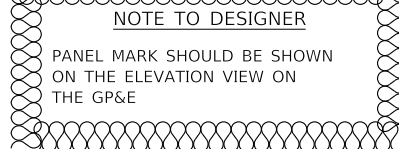
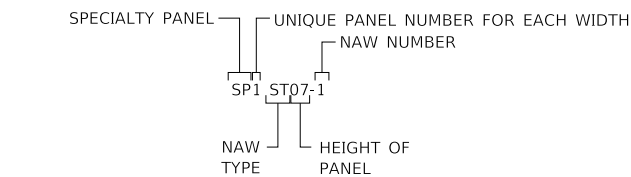
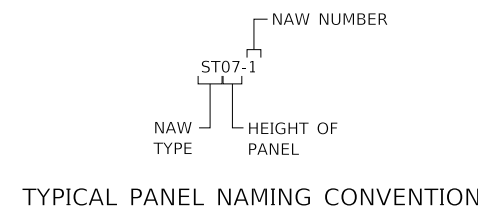

NOTE TO DESIGNER

THIS BASE SHEET SHOWS TYPICAL CONSTRUCTION BUT IT IS NOT A STANDARD DRAWING. IT REQUIRES COMPLETION BY THE DESIGNER PRIOR TO INSERTION INTO A CONTRACT. MICROSTATION FILES AND THE "CADD STANDARDS MANUAL" ARE AVAILABLE ON THE ILLINOIS TOLLWAY WEBSITE. THE DESIGNER SHALL ACCEPT THE RESPONSIBILITY OF THE DESIGN OF THIS SHEET UPON ITS COMPLETION AND INSERTION INTO A CONTRACT. ALL "NOTE TO DESIGNER" BOXES SHALL BE REMOVED BY THE DESIGNER PRIOR TO INSERTION OF THE SHEET INTO THE PLAN SET.

LIST OF ABBREVIATIONS

AASHTO	AMERICAN ASSOCIATION OF STATE HIGHWAY AND TRANSPORTATION OFFICIALS
ABUT.	ABUTMENT
BK.	BACK
B.F.	BACK FACE
BL	BASELINE
BRG.	BEARING
BOTT.	BOTTOM
B/	BOTTOM OF
BM	BRIDGE MOUNTED
CL	CENTERLINE
COL.	COLUMN
CONC.	CONCRETE
CGM	CRASHWORTHY GROUND MOUNTED
E.E.	EACH END
E.	EAST
EB	EASTBOUND
ELEV.	ELEVATION
EQ.	EQUAL
EXIST.	EXISTING
EXP.	EXPANSION
F.F.	FRONT FACE
JT.	JOINT
LOC.	LOCATION
MAX.	MAXIMUM
MIN.	MINIMUM
NAW	NOISE ABATEMENT WALL
N.	NORTH
N.A.	NOT APPLICABLE
O.C.	ON CENTER
PL	PLATE
PVC	POINT OF VERTICAL CURVE
PVI	POINT OF VERTICAL INTERSECTION
PVT	POINT OF VERTICAL TANGENCY
PROP.	PROPOSED
SHLDR.	SHOULDER
S.	SOUTH
S.P.	SPECIAL PROVISION
SQ. FT.	SQUARE FOOT
SQ. YD.	SQUARE YARD
STA.	STATION
STRUCT	STRUCTURAL
S.M.	STRUCTURE MOUNTED
T/	TOP OF
TYP.	TYPICAL
U.N.O.	UNLESS NOTED OTHERWISE
WB	WESTBOUND
WF	WIDE FLANGE

NOTE TO DESIGNER
DESIGNER TO COMPLETE TABLES.

**CENTRAL TRI-STATE
STRUCTURE MOUNTED NOISE
ABATEMENT WALL SCHEDULE**

VERSION: 2024-03	STANDARD: M-BRG-531	SHEET: 3 OF 4
---------------------	------------------------	------------------



NOTE TO DESIGNER

THE BASE SHEET SHOWS TYPICAL CONSTRUCTION BUT IS NOT A STANDARD DRAWING. IT REQUIRES COMPLETION BY THE DSE PRIOR TO INSERTION INTO A CONTRACT. THE DSE SHALL ACCEPT RESPONSIBILITY OF THE DESIGN UPON ITS COMPLETION AND INSERTION INTO A CONTRACT.

THIS BASE SHEET REPRESENTS THE TYPICAL DETAILS FOR STRUCTURE MOUNTED, NOISE ABATEMENT WALLS. THE DSE IS RESPONSIBLE FOR COMPLETING THE TABLES AND INCLUDE IN THEIR CONTRACT PLANS. IF ANY OF THE DESIGN PARAMETERS IN THE ILLINOIS TOLLWAY STANDARD ARE EXCEEDED, THE DSE WILL BE RESPONSIBLE FOR DESIGN CALCULATIONS AND DETAILS FOR THOSE COMPONENTS.

THE PLAN AND ELEVATION ON THIS COVER SHEET REPRESENTS ADDITIONAL INFORMATION TO SHOW ON THE GP&E SHEET. THE GP&E SHEET AND REMAINING NAW PLANS SHALL BE IN ACCORDANCE WITH ILLINOIS TOLLWAY STRUCTURE DESIGN MANUAL ARTICLES 6.2.5 AND 23.3.

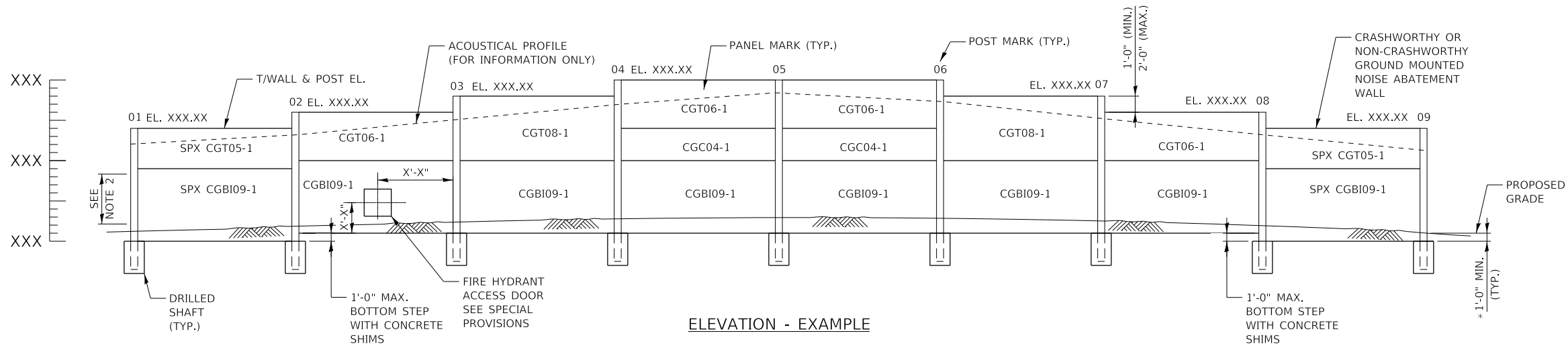
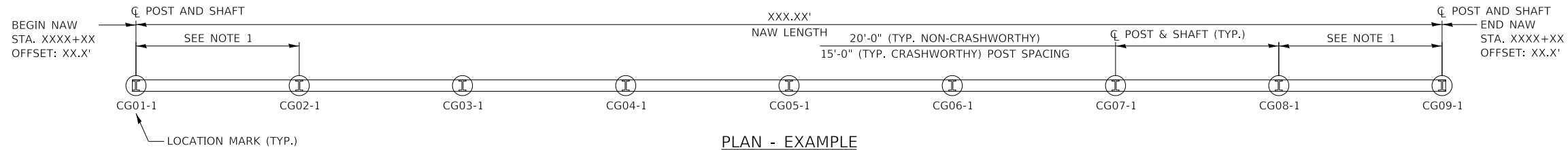

NOTE TO DESIGNER

NOTE:

- USE SPECIALTY PANEL AND POST SPACING AT ENDS OF WALL OR UNIQUE LOCATIONS SUCH AS UTILITY CROSSINGS TO ACCOMMODATE TYPICAL 20'-0" OR 15'-0" POST SPACING FOR NON-CRASHWORTHY OR CRASHWORTHY, RESPECTIVELY ALONG THE MAJORITY OF THE LENGTH OF WALL. POST SPACING SHOULD NOT EXCEED LIMITS WITHIN THE ILLINOIS TOLLWAY STANDARD. IF LIMITS ARE EXCEEDED, DSE TO DESIGN AND DETAIL ALL COMPONENTS. THE "SPX" DESIGNATION FOR SPECIALTY PANELS SHOULD BE USED FOR ALL PANELS WITHIN THAT BAY WITH THE SAME WIDTH.
- FOR CRASHWORTHY NAW, PANELS WITHIN 6FT ABOVE FACE OF ROADWAY PAVEMENT SHALL BE THE TL-4 IMPACT PANELS.

NOTE TO DESIGNER

* INCREASE TO ACCOMMODATE THE GUTTER WHEN NEEDED

NOTE TO DESIGNER

ALL SIGNS MOUNTED TO NAW SHALL BE SHOWN ON GP&E IN ACCORDANCE WITH LATEST ILLINOIS TOLLWAY DETAIL FOR NOISE ABATEMENT WALL MOUNTED SIGN SUPPORT.

NOTE TO DESIGNER

* INCREASE TO ACCOMMODATE THE GUTTER WHEN NEEDED

NOTE TO DESIGNER

SEE BASE SHEET M-BRG-532 SHEET 2 OF 3 FOR PANEL DESIGNATIONS AND M-BRG-532 SHEET 3 OF 3 FOR POST DESIGNATIONS TO BE SHOWN ON THIS SHEET

NOTE TO DESIGNER

INCLUDE ACOUSTICAL PROFILE FOR INFORMATION ONLY.

NOTE TO DESIGNER

ELEVATIONS SHOULD ACCOUNT FOR 1/4" GAP BETWEEN PANELS.



GROUND MOUNTED NOISE ABATEMENT WALL COVER SHEET

VERSION: 2024-03 STANDARD: M-BRG-532 SHEET: 1 OF 4

NON-CRASHWORTHY NAW GROUND MOUNTED PANEL SCHEDULE				
PANEL MARK	PANEL HEIGHT	PANEL WIDTH	TOTAL PANEL THICKNESS	NUMBER OF PANELS
GB04-1	4'-0"	19'-10"	7"	X
GBU04-1	4'-0"	19'-10"	7"	X
**GC04-1	4'-0"	19'-10"	7"	X
GT04-1	4'-0"	19'-10"	7"	X
GT05-1	5'-0"	19'-10"	7"	X
GT06-1	6'-0"	19'-10"	7"	X
GT07-1	7'-0"	19'-10"	7"	X
GT08-1	8'-0"	19'-10"	7"	X
GTF04-1	4'-0"	19'-10"	7"	X
GTF05-1	5'-0"	19'-10"	7"	X
GTF06-1	6'-0"	19'-10"	7"	X
GTF07-1	7'-0"	19'-10"	7"	X
GTF08-1	8'-0"	19'-10"	7"	X
GTFU04-1	4'-0"	19'-10"	9"	X
GTFU05-1	5'-0"	19'-10"	9"	X
GTFU06-1	6'-0"	19'-10"	9"	X
GTFU07-1	7'-0"	19'-10"	9"	X
GTFU08-1	8'-0"	19'-10"	9"	X
SPX GB04-1	4'-0"	19'-10"	7"	X
SPX GBU04-1	4'-0"	19'-10"	9"	X
**SPX GC04-1	4'-0"	19'-10"	7"	X
SPX GT04-1	4'-0"	19'-10"	7"	X
SPX GT05-1	5'-0"	19'-10"	7"	X
SPX GT06-1	6'-0"	19'-10"	7"	X
SPX GT07-1	7'-0"	19'-10"	7"	X
SPX GT08-1	8'-0"	19'-10"	7"	X
SPX GTF04-1	4'-0"	19'-10"	7"	X
SPX GTF05-1	5'-0"	19'-10"	7"	X
SPX GTF06-1	6'-0"	19'-10"	7"	X
SPX GTF07-1	7'-0"	19'-10"	7"	X
SPX GTF08-1	8'-0"	19'-10"	7"	X
SPX GTFU04-1	4'-0"	19'-10"	9"	X
SPX GTFU05-1	5'-0"	19'-10"	9"	X
SPX GTFU06-1	6'-0"	19'-10"	9"	X
SPX GTFU07-1	7'-0"	19'-10"	9"	X
SPX GTFU08-1	8'-0"	19'-10"	9"	X

NOTE:
1. WORK THIS SHEET WITH ILLINOIS TOLLWAY STANDARDS G15 AND G16.

GENERAL NOTES

1. CONTRACTOR SHALL NOT SCALE DIMENSIONS FROM THE CONTRACT PLANS FOR CONSTRUCTION PURPOSES. SCALES SHOWN ARE FOR INFORMATION ONLY.
2. NO CONSTRUCTION JOINTS EXCEPT THOSE SHOWN ON THE PLANS SHALL BE ALLOWED UNLESS APPROVED BY THE ENGINEER.
3. THE CONTRACTOR MAY REQUEST COPIES OF EXISTING CONSTRUCTION PLANS THAT ARE CURRENTLY ON FILE WITH THE ILLINOIS TOLLWAY. THE REQUEST SHALL BE IN WRITING WITH THE UNDERSTANDING THAT ANY REPRODUCTION COST WILL BE AT THE CONTRACTOR'S EXPENSE AT NO ADDITIONAL COST TO THE ILLINOIS TOLLWAY.
4. NO CONCRETE CUTTING SHALL BE PERMITTED UNTIL THE CUTTING LIMITS HAVE BEEN OUTLINED BY THE CONTRACTOR AND APPROVED BY THE ENGINEER.
5. IT SHALL BE THE CONTRACTOR'S RESPONSIBILITY TO VERIFY THE LOCATION OF ALL UTILITIES PRIOR TO STARTING CONSTRUCTION. CONTACT J.U.L.I.E., 800-892-0123.
6. IT SHALL BE THE CONTRACTOR'S RESPONSIBILITY TO VERIFY THE LOCATION OF ALL FIBER OPTIC UTILITIES PRIOR TO STARTING CONSTRUCTION. THE CONTRACTOR SHALL INITIATE THE LOCATION PROCESS FOR THE FIBER OPTIC CABLE BY COMPLETING A "REQUEST ILLINOIS TOLLWAY UTILITIES LOCATE" FORM ONLINE AT THE ILLINOIS TOLLWAY WEBSITE UNDER "DOING BUSINESS" AT LEAST FOUR (4) BUSINESS DAYS PRIOR TO STARTING ANY UNDERGROUND OPERATIONS, EXCAVATIONS OR DIGGING OF ANY TYPE IN THE GENERAL AREA OF THE FIBER OPTIC CABLE."
7. THE SOIL BORING LOGS REPRESENT POINT INFORMATION. PRESENTATION OF THIS INFORMATION IN NO WAY IMPLIES THAT SUBSURFACE CONDITIONS ARE THE SAME AT LOCATIONS OTHER THAN THE EXACT LOCATION OF THE BORING.
8. WHENEVER ANY MATERIAL IS DEPOSITED INTO A DRAINAGE SYSTEM OR DRAINAGE STRUCTURES, THE DEPOSITED MATERIAL SHALL BE REMOVED AT THE CLOSE OF EACH WORKING DAY. AT THE CONCLUSION OF CONSTRUCTION OPERATIONS, ALL DRAINAGE SYSTEMS AND STRUCTURES SHALL BE FREE FROM DIRT AND DEBRIS DEPOSITED DURING THE VARIOUS CONSTRUCTION OPERATIONS.

CRASHWORTHY NAW GROUND MOUNTED PANEL SCHEDULE (NO TL-4 IMPACT)				
PANEL MARK	PANEL HEIGHT	PANEL WIDTH	TOTAL PANEL THICKNESS	NUMBER OF PANELS
*CGC04-1	4'-0"	14'-10"	9"	X
CGT05-1	5'-0"	14'-10"	9"	X
CGT06-1	6'-0"	14'-10"	9"	X
CGT07-1	7'-0"	14'-10"	9"	X
CGT08-1	8'-0"	14'-10"	9"	X
CGT09-1	9'-0"	14'-10"	9"	X
*SPX CGC04-1	4'-0"	X'-X"	9"	X
SPX CGT05-1	5'-0"	X'-X"	9"	X
SPX CGT06-1	6'-0"	X'-X"	9"	X
SPX CGT07-1	7'-0"	X'-X"	9"	X
SPX CGT08-1	8'-0"	X'-X"	9"	X
SPX CGT09-1	9'-0"	X'-X"	9"	X

*CONTRACTOR MAY INCREASE THE STANDARD CENTER PANEL HEIGHTS, MAXIMUM 9FT, TO MINIMIZE THE NUMBER OF JOINTS. THE ADJACENT TOP PANEL MAY ALSO BE ADJUSTED, PROVIDED STANDARD PANEL HEIGHTS AS SHOWN IN STANDARD G16 ARE USED. CONTRACTOR SHALL SUBMIT SHOP DRAWINGS TO THE ENGINEER FOR REVIEW PRIOR TO INSTALLATION.

**CONTRACTOR MAY INCREASE THE STANDARD CENTER PANEL HEIGHTS, MAXIMUM 8FT, TO MINIMIZE THE NUMBER OF JOINTS. THE ADJACENT TOP PANEL MAY ALSO BE ADJUSTED, PROVIDED STANDARD PANEL HEIGHTS AS SHOWN IN STANDARD G15 ARE USED. CONTRACTOR SHALL SUBMIT SHOP DRAWINGS TO THE ENGINEER FOR REVIEW PRIOR TO INSTALLATION.

LIST OF ABBREVIATIONS

- AASHTO AMERICAN ASSOCIATION OF STATE HIGHWAY AND TRANSPORTATION OFFICIALS
- ABUT. ABUTMENT
- BK. BACK
- B.F. BACK FACE
- ℄ BASELINE
- BRG. BEARING
- BOTT. BOTTOM
- B/ BOTTOM OF
- BM BRIDGE MOUNTED
- ℄ CENTERLINE
- CL. CLEARANCE
- COL. COLUMN
- CONC. CONCRETE
- CGM CRASHWORTHY GROUND MOUNTED
- E.E. EACH END
- E. EAST
- EB EASTBOUND
- ELEV. ELEVATION
- EQ. EQUAL
- EXIST. EXISTING
- EXP. EXPANSION
- F.F. FRONT FACE
- JT. JOINT
- LOC. LOCATION
- MAX. MAXIMUM
- MIN. MINIMUM
- NAW NOISE ABATEMENT WALL
- N. NORTH
- N.A. NOT APPLICABLE
- O.C. ON CENTER
- ℄ PLATE
- PVC POINT OF VERTICAL CURVE
- PVI POINT OF VERTICAL INTERSECTION
- PVT POINT OF VERTICAL TANGENCY
- PROP. PROPOSED
- SHLDR. SHOULDER
- S. SOUTH
- S.P. SPECIAL PROVISION
- SQ. FT. SQUARE FOOT
- SQ. YD. SQUARE YARD
- STA. STATION
- STRUCT. STRUCTURAL
- S.M. STRUCTURE MOUNTED
- T/ TOP OF
- TYP. TYPICAL
- U.N.O. UNLESS NOTED OTHERWISE
- WB WESTBOUND
- WF WIDE FLANGE

CRASHWORTHY NAW GROUND MOUNTED PANEL SCHEDULE (TL-4 IMPACT)				
PANEL MARK	PANEL HEIGHT	PANEL WIDTH	TOTAL PANEL THICKNESS	NUMBER OF PANELS
CGBI06-1	6'-0"	14'-10"	11"	X
CGBI07-1	7'-0"	14'-10"	11"	X
CGBI08-1	8'-0"	14'-10"	11"	X
CGBI09-1	9'-0"	14'-10"	11"	X
CGCI06-1	6'-0"	14'-10"	11"	X
CGCI07-1	7'-0"	14'-10"	11"	X
CGCI08-1	8'-0"	14'-10"	11"	X
CGCI09-1	9'-0"	14'-10"	11"	X
CGTI06-1	6'-0"	14'-10"	11"	X
CGTI07-1	7'-0"	14'-10"	11"	X
CGTI08-1	8'-0"	14'-10"	11"	X
CGTI09-1	9'-0"	14'-10"	11"	X
CGTFI06-1	6'-0"	14'-10"	11"	X
CGTFI07-1	7'-0"	14'-10"	11"	X
CGTFI08-1	8'-0"	14'-10"	11"	X
CGTFI09-1	9'-0"	14'-10"	11"	X
SPX CGBI06-1	6'-0"	X'-X"	11"	X
SPX CGBI07-1	7'-0"	X'-X"	11"	X
SPX CGBI08-1	8'-0"	X'-X"	11"	X
SPX CGBI09-1	9'-0"	X'-X"	11"	X
SPX CGCI06-1	6'-0"	X'-X"	11"	X
SPX CGCI07-1	7'-0"	X'-X"	11"	X
SPX CGCI08-1	8'-0"	X'-X"	11"	X
SPX CGCI09-1	9'-0"	X'-X"	11"	X
SPX CGTI06-1	6'-0"	X'-X"	11"	X
SPX CGTI07-1	7'-0"	X'-X"	11"	X
SPX CGTI08-1	8'-0"	X'-X"	11"	X
SPX CGTI09-1	9'-0"	X'-X"	11"	X
SPX CGTFI06-1	6'-0"	X'-X"	11"	X
SPX CGTFI07-1	7'-0"	X'-X"	11"	X
SPX CGTFI08-1	8'-0"	X'-X"	11"	X
SPX CGTFI09-1	9'-0"	X'-X"	11"	X

NOTE TO DESIGNER

THIS BASE SHEET SHOWS TYPICAL CONSTRUCTION BUT IT IS NOT A STANDARD DRAWING. IT REQUIRES COMPLETION BY THE DESIGNER PRIOR TO INSERTION INTO A CONTRACT. MICROSTATION FILES AND THE "CADD STANDARDS MANUAL" ARE AVAILABLE ON THE ILLINOIS TOLLWAY WEBSITE. THE DESIGNER SHALL ACCEPT THE RESPONSIBILITY OF THE DESIGN OF THIS SHEET UPON ITS COMPLETION AND INSERTION INTO A CONTRACT. ALL "NOTE TO DESIGNER" BOXES SHALL BE REMOVED BY THE DESIGNER PRIOR TO INSERTION OF THE SHEET INTO THE PLAN SET.

NOTE TO DESIGNER

PANEL MARK SHOULD BE SHOWN ON THE ELEVATION VIEW ON THE GP&E

NOTE TO DESIGNER

DESIGNER TO COMPLETE TABLES.

NAW TYPE

- GTF= NON-CRASHWORTHY GROUND MOUNTED FULL HEIGHT PANEL
 * GTFU= NON-CRASHWORTHY GROUND MOUNTED FULL HEIGHT PANEL (UNBALANCED SOIL LOAD)
 GT = NON-CRASHWORTHY GROUND MOUNTED TOP PANEL
 GC = NON-CRASHWORTHY GROUND MOUNTED CENTER PANEL
 GB = NON-CRASHWORTHY GROUND MOUNTED BOTTOM PANEL
 * GBU = NON-CRASHWORTHY GROUND MOUNTED BOTTOM PANEL (UNBALANCED SOIL LOAD)
 ** CGT = CRASHWORTHY GROUND MOUNTED TOP PANEL (NO TL-4 IMPACT)
 ** CGC = CRASHWORTHY GROUND MOUNTED CENTER PANEL (NO TL-4 IMPACT)
 **** CGTFI = CRASHWORTHY GROUND MOUNTED FULL HEIGHT PANEL (TL-4 IMPACT)
 **** CGTI = CRASHWORTHY GROUND MOUNTED TOP PANEL (TL-4 IMPACT)
 **** CGCI = CRASHWORTHY GROUND MOUNTED CENTER PANEL (TL-4 IMPACT)
 **** CGBI = CRASHWORTHY GROUND MOUNTED BOTTOM PANEL (TL-4 IMPACT)
 SP = SPECIALTY PANEL

- * THESE PANELS HAVE BEEN DESIGNED FOR THE MAXIMUM UNBALANCED SOIL LOAD.
 ** THESE PANELS HAVE BEEN DESIGNED FOR THE 4KIP VEHICLE COLLISION LOADING.
 *** THESE PANELS HAVE BEEN DESIGNED FOR THE 54KIP TL-4 VEHICLE COLLISION LOADING.

DESIGN SPECIFICATIONS

ILLINOIS TOLLWAY STRUCTURE DESIGN MANUAL, DATED XXXXXXXXXXXXXXXX.

ILLINOIS TOLLWAY GEOTECHNICAL MANUAL, DATED XXXXXXXXXXXXXXXX.

AASHTO LRFD BRIDGE DESIGN SPECIFICATIONS, DATED XXXXXXXXXXXXXXXX.

CONSTRUCTION SPECIFICATIONS

ILLINOIS DEPARTMENT OF TRANSPORTATION LATEST GUIDE BRIDGE SPECIAL PROVISIONS (GBSPs)

ILLINOIS TOLLWAY SUPPLEMENTAL SPECIFICATIONS TO THE ILLINOIS DEPARTMENT OF TRANSPORTATION STANDARD SPECIFICATIONS FOR ROAD AND BRIDGE CONSTRUCTION, DATED XXXXXXXXXXXXXXXX.

ILLINOIS DEPARTMENT OF TRANSPORTATION SUPPLEMENTAL SPECIFICATIONS AND RECURRING SPECIAL PROVISIONS, DATED XXXXXXXXXXXXXXXX.

ILLINOIS DEPARTMENT OF TRANSPORTATION STANDARD SPECIFICATIONS FOR ROAD AND BRIDGE CONSTRUCTION, DATED XXXXXXXXXXXXXXXX.

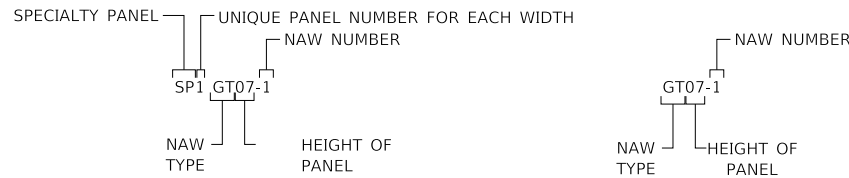

SPECIALTY PANEL NAMING CONVENTION

TYPICAL PANEL NAMING CONVENTION



GROUND MOUNTED NOISE ABATEMENT WALL SCHEDULE

VERSION: 2024-03 STANDARD: M-BRG-532 SHEET: 2 OF 4

DRILLED SHAFT SCHEDULE									
LOC MARK	STATION	OFFSET	T/ SHAFT EL.	B/ SHAFT EL.	SHAFT DEPTH	SHAFT DIAMETER	B/ POST EMBED EL.	POST EMBED DEPTH	POST MARK
G01-1	XXX+XX.XX	XX.XX	XXX.XX	XXX.XX	XX.XX	X'-XX"	XXX.XX	XXX.XX	01
G02-1	XXX+XX.XX	XX.XX	XXX.XX	XXX.XX	XX.XX	X'-XX"	XXX.XX	XXX.XX	02
G03-1	XXX+XX.XX	XX.XX	XXX.XX	XXX.XX	XX.XX	X'-XX"	XXX.XX	XXX.XX	03
G04-1	XXX+XX.XX	XX.XX	XXX.XX	XXX.XX	XX.XX	X'-XX"	XXX.XX	XXX.XX	04
G05-1	XXX+XX.XX	XX.XX	XXX.XX	XXX.XX	XX.XX	X'-XX"	XXX.XX	XXX.XX	05
G06-1	XXX+XX.XX	XX.XX	XXX.XX	XXX.XX	XX.XX	X'-XX"	XXX.XX	XXX.XX	06
G07-1	XXX+XX.XX	XX.XX	XXX.XX	XXX.XX	XX.XX	X'-XX"	XXX.XX	XXX.XX	07
G08-1	XXX+XX.XX	XX.XX	XXX.XX	XXX.XX	XX.XX	X'-XX"	XXX.XX	XXX.XX	08
G09-1	XXX+XX.XX	XX.XX	XXX.XX	XXX.XX	XX.XX	X'-XX"	XXX.XX	XXX.XX	09
G10-1	XXX+XX.XX	XX.XX	XXX.XX	XXX.XX	XX.XX	X'-XX"	XXX.XX	XXX.XX	10
G11-1	XXX+XX.XX	XX.XX	XXX.XX	XXX.XX	XX.XX	X'-XX"	XXX.XX	XXX.XX	11

STEEL POST SCHEDULE			
POST MARK	STEEL POST SIZE	POST LENGTH	T/ WALL & POST EL.
01	WXxXX	XX'-XX"	XXX.XX
02	WXxXX	XX'-XX"	XXX.XX
03	WXxXX	XX'-XX"	XXX.XX
04	WXxXX	XX'-XX"	XXX.XX
05	WXxXX	XX'-XX"	XXX.XX
06	WXxXX	XX'-XX"	XXX.XX
07	WXxXX	XX'-XX"	XXX.XX
08	WXxXX	XX'-XX"	XXX.XX
09	WXxXX	XX'-XX"	XXX.XX
10	WXxXX	XX'-XX"	XXX.XX
11	WXxXX	XX'-XX"	XXX.XX

TOTAL BILL OF MATERIAL (NO ADVANCE PROCUREMENT)			
PAY ITEM NO.	ITEM	UNIT	TOTAL
JT599910	PRECAST CONCRETE NOISE ABATEMENT WALL, GROUND MOUNTED, NON-CRASHWORTHY	SQ. FT.	X
JT599915	PRECAST CONCRETE NOISE ABATEMENT WALL, GROUND MOUNTED, CRASHWORTHY	SQ. FT.	X

TOTAL BILL OF MATERIAL (ADVANCE PROCUREMENT)			
PAY ITEM NO.	ITEM	UNIT	TOTAL
JJ504510	FURNISHING PRECAST CONCRETE PANELS, NOISE ABATEMENT WALL PANELS, GROUND MOUNTED, NON-CRASHWORTHY	SQ. FT.	X
JJ504515	FURNISHING PRECAST CONCRETE PANELS, NOISE ABATEMENT WALL PANELS, GROUND MOUNTED, CRASHWORTHY 13"	SQ. FT.	X
JJ504516	FURNISHING PRECAST CONCRETE PANELS, NOISE ABATEMENT WALL PANELS, GROUND MOUNTED, CRASHWORTHY 9"	SQ. FT.	X
JJ504550	STORAGE OF PRECAST CONCRETE PANELS, NOISE ABATEMENT WALL	CAL. DAY	X
JJ505230	FURNISHING STRUCTURAL STEEL, NOISE ABATEMENT WALL	LBS.	X
JJ505500	STORAGE OF STRUCTURAL STEEL, NOISE ABATEMENT WALL	CAL. DAY	X
JT599900	INSTALLING PRECAST CONCRETE NOISE ABATEMENT WALL, GROUND MOUNTED	SQ. FT.	X

ADVANCE PROCUREMENT NOTES:

FOR THE FABRICATION CONTRACT

PICK UP OF THE NOISE ABATEMENT WALL STRUCTURAL STEEL FROM THE CONTRACTORS STORAGE IS ANTICIPATED FROM (XXXX- TO XXX). PICK UP OF THE PRECAST CONCRETE NOISE ABATEMENT PANELS FROM THE CONTRACTORS STORAGE IS ANTICIPATED FROM (XXXX- TO XXX). OR COMBINE TO PICK UP OF THE MATERIALS FROM THE CONTRACTORS STORAGE IS ANTICIPATED FROM (XXXX- TO XXX).

FOR THE INSTALLATION CONTRACT

THE MATERIAL FOR THE PRECAST CONCRETE NOISE ABATEMENT WALLS ARE STORED FOR PICK UP AT (XXXXXX). THE PICKUP OF THE MATERIAL IS ANTICIPATED FROM (XXXXX TO XXXX).

NAW TYPE

G = NON-CRASHWORTHY GROUND MOUNTED
CG = CRASHWORTHY GROUND MOUNTED



POST MARK CONVENTION

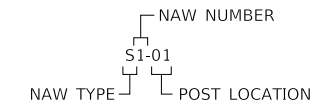

LOCATION MARK CONVENTION

NOTE TO DESIGNER

LOCATION AND POST MARKS SHOULD BE SHOWN ON THE GENERAL LAYOUT OF POSTS ON THE GP&E

NOTE TO DESIGNER

THIS BASE SHEET SHOWS TYPICAL CONSTRUCTION BUT IT IS **NOT** A STANDARD DRAWING. IT REQUIRES COMPLETION BY THE DESIGNER PRIOR TO INSERTION INTO A CONTRACT. MICROSTATION FILES AND THE "CADD STANDARDS MANUAL" ARE AVAILABLE ON THE ILLINOIS TOLLWAY WEBSITE. THE DESIGNER SHALL ACCEPT THE RESPONSIBILITY OF THE DESIGN OF THIS SHEET UPON ITS COMPLETION AND INSERTION INTO A CONTRACT. ALL "NOTE TO DESIGNER" BOXES SHALL BE REMOVED BY THE DESIGNER PRIOR TO INSERTION OF THE SHEET INTO THE PLAN SET.

NOTE TO DESIGNER

DESIGNER TO SELECT APPROPRIATE TOTAL BILL OF MATERIAL AND INCLUDE ONLY ONE IN PLANS BASED ON IF ADVANCE PROCUREMENT CONTRACT IS USED OR NOT.

NOTE TO DESIGNER

DESIGNER TO COMPLETE TABLES.

* POST IS LOCATED AT 90° TURN AND REQUIRES ADDITIONAL ANGLES WELDED TO FLANGE.



GROUND MOUNTED NOISE ABATEMENT WALL SCHEDULE

