

Illinois Tollway Base Sheet Revisions
--

Section M	Base Sheet Drawings	
Drawing	Modification Summary	Effective: 03-01-2024
Tower Mounted Camera Assembly (ITS) - Series 1500		
M-ITS-1500	ITS Details Tower Mount Camera Details	
	Removed Elevation A-A Enclosure Mounted Tower Leg detail.	
	Added note to Designer: Camera controls are located in the Video Power Junction Box in the Plaza Communication room	
	Removed reference to Note 23 in CCTV Equipment Mounting Scheme Lattice Tower detail	
	Removed reference to Note 22 in CCTV Equipment Mounting Scheme Lattice Tower detail	
	Removed reference to Note 21 in CCTV Equipment Mounting Scheme Lattice Tower detail	
	Note 12: updated wording to add Unless included as part of...	
	Note 14: updated wording to add Below the junction box ...	
	Note 14: updated spelling of Relief	
Removed reference to Note 20 in CCTV Equipment Mounting Scheme Lattice Tower detail		
M-ITS-1502	Fix format of Note 3	
	Fix format of Note 6	
	Fix format of Note 12	
	Remove reference to Note 5 on Tower Assembly detail	
M-ITS-1503	Cabinet Wiring Diagram Tower Mounted CCTV ITS Assembly	
	ITS enclosure is no longer required at the base of the tower and has been replaced by a Video Power Junction Box Model A NEMA 1 to be installed in the plaza communication room.	
	Remove box shown by error on the drawing	
	Moved cable to cable port connected to IP Relay	
	Add missing line on terminal block near TB1A	

 New Sheet

 Retired Standard

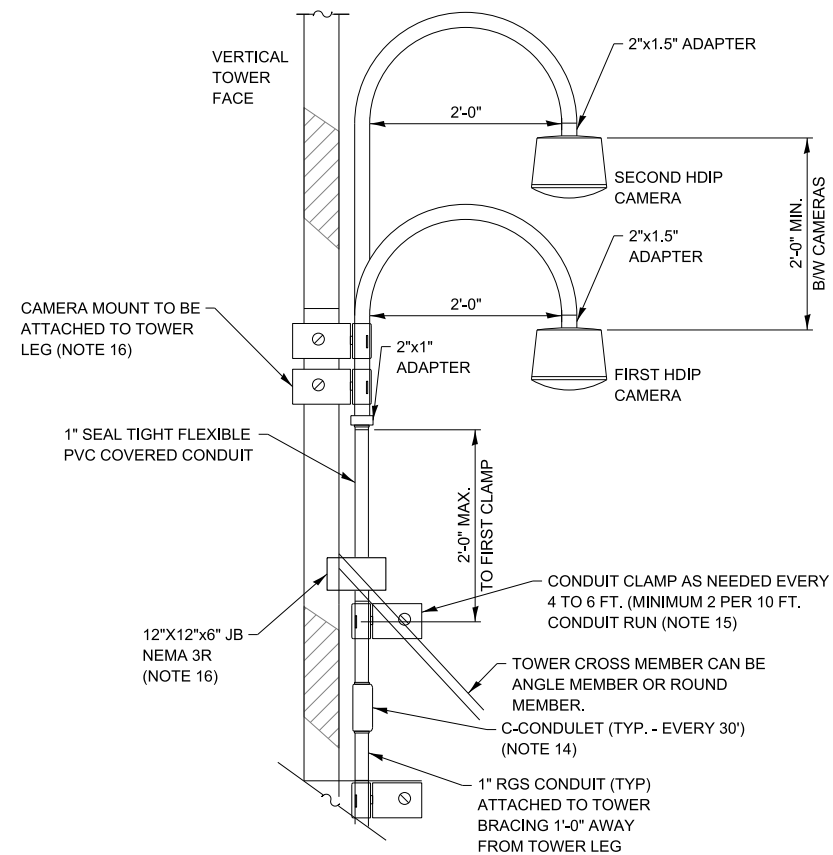

CCTV EQUIPMENT MOUNTING SCHEME
LATTICED TOWER
 NOT TO SCALE

NOTE TO DESIGNER
 THIS BASE SHEET SHOWS TYPICAL CONSTRUCTION BUT IT IS NOT A STANDARD DRAWING. IT REQUIRES COMPLETION BY THE DESIGNER PRIOR TO INSERTION INTO A CONTRACT. MICROSTATION FILES AND THE "CADD STANDARDS MANUAL" ARE AVAILABLE ON THE ILLINOIS TOLLWAY WEBSITE. THE DESIGNER SHALL ACCEPT THE RESPONSIBILITY OF THE DESIGN OF THIS SHEET UPON ITS COMPLETION AND INSERTION INTO A CONTRACT. ALL "NOTE TO DESIGNER" BOXES SHALL BE REMOVED BY THE DESIGNER PRIOR TO INSERTION OF THE SHEET INTO THE PLAN SET.

NOTE TO DESIGNER
 ROUTING OF CONDUIT AND CABLES TO PLAZA/TOWER BUILDING SHALL BE SHOWN FOR EACH INSTALLATION OCCURRENCE DEPICTING ACTUAL CONDITIONS. INSTALLATION AND ROUTING OF EQUIPMENT AND CABLES SHALL BE SHOWN IN PLAN VIEW FORMAT AS WELL AS A DESCRIPTION OF THE LOCATION AND POSITION OF WALL MOUNT, RACK MOUNT AND CABLE TRAY POSITIONS WITHIN THE PLAZA/TOWER BUILDING. CISCO SWITCH PORTS TO BE USED SHALL BE IDENTIFIED.

NOTE TO DESIGNER
 THE 2 CCTV'S SHALL BE PLACED ON THE LEG FACING THE ROADWAY WITH A CLEAR FIELD OF VIEW.

NOTE TO DESIGNER
 CAMERA CONTROLS ARE LOCATED IN THE VIDEO POWER JUNCTION BOX IN THE PLAZA COMMUNICATION ROOM.

ABBREVIATIONS:

AISC	AMERICAN INSTITUTE OF STEEL CONSTRUCTION
ASCE	AMERICAN SOCIETY OF CIVIL ENGINEERS
TIA	TELECOMMUNICATION INDUSTRY ASSOCIATION
RGS	RIGID GALVANIZED STEEL
JB	JUNCTION BOX

GENERAL NOTES:

1. CONTRACTOR IS RESPONSIBLE FOR FINAL ATTACHMENT DETAILS BASED ON THE DRAWINGS AND PRE-INSTALLATION MEETING WITH ILLINOIS TOLLWAY.
2. APPLICABLE DESIGN CRITERIA SHALL BE PER THE LATEST EDITION OF AISC MANUAL, ASCE 7-05, TIA-222-G, AND APPLICABLE NATIONAL, STATE, AND OR LOCAL BUILDING CODES.
3. EQUIPMENT MOUNTING SHALL ALSO MEET REQUIREMENTS LISTED IN SPECIAL PROVISIONS.
4. DESIGN LOADS SHALL BE AS FOLLOWS:
 - A. DEAD LOADS SHALL INCLUDE ALL EQUIPMENT LOADS, INCLUDING CONDUIT AND MOUNTING LOADS SHALL BE CONSIDERED IN THE DESIGN. PTZ HDIP CAMERA WEIGHT SHALL BE ASSUMED TO WEIGH MINIMUM 10.14 LBS. ACTUAL LOAD SHALL BE VERIFIED FOR THE SPECIFIED MODEL FROM VENDOR.
 - B. DESIGN SEISMIC ACCELERATION AND WIND SPEED SHOULD BE DETERMINED FROM APPLICABLE BUILDING CODES AND DESIGN STANDARDS.
 - C. DESIGN LOAD COMBINATIONS SHOULD BE DETERMINED FROM APPLICABLE BUILDING CODES AND DESIGN STANDARDS. DESIGN SHALL BE BASED ON ALLOWABLE STRESS DESIGN (A.S.D.) METHOD.
5. MOUNTING HEIGHTS FOR CAMERA WILL BE AS CLOSE TO TOWER TOP AS PRACTICAL, UNLESS THE OR ENGINEER SPECIFIES OTHERWISE. THE PLAN LOCATION SHALL BE COORDINATED WITH THE ILLINOIS TOLLWAY AND ENGINEER.
6. NO HOLES CAN BE DRILLED AND NO WELDING IS ALLOWED INTO TOWER MEMBERS. DO NOT MOUNT RIGID CONDUIT TO TRANSMISSION LINE LADDER. CAMERA AND ANTENNA SHALL BE MOUNTED ON TOWER VERTICAL LEGS ONLY AT A MINIMUM OF 1'-0" AWAY FROM TOWER LEG.
7. CONDUIT HANGERS AND MANUFACTURER SHOWN IN DRAWINGS ARE REPRESENTATIVE ONLY. CONTRACTOR SHALL ONLY CHOOSE MANUFACTURED HARDWARE THAT HAS A RATED "DESIGN LOAD" FROM THE VENDOR AND IS CAPABLE OF RESISTING ALL APPLIED LOADS. A MINIMUM FACTOR OF SAFETY OF 5 SHALL BE ENSURED. VENDOR SPECIFIED "DESIGN LOAD" BASED ON F.S. < 5 SHALL BE PROPORTIONATELY DERATED (E.G. IF DESIGN LOAD IS BASED ON F.S. OF 3, IT SHALL BE DERATED TO 60%).
8. NOT USED.
9. CONTRACTOR IS RESPONSIBLE FOR THEIR QUALITY CONTROL AND PROVIDING DOCUMENTATION THAT ALL BOLTS ARE TORQUED AND HARDWARE TIGHTENED TO MANUFACTURER'S ESTABLISHED REQUIREMENTS.
10. CONTRACTOR, THROUGH THE ENGINEER, SHALL COORDINATE CAMERA AND ANTENNA MOUNTING WITH ILLINOIS TOLLWAY'S TOWER CREW, AT LEAST ONE WEEK BEFORE PROPOSED INSTALLATION. CONTRACTOR SHALL PROVIDE ALL MATERIALS, TOOLS AND EQUIPMENT FOR COMPLETE INSTALLATION OF CAMERA AND ANTENNAS AT EACH PLAZA.
11. NOT USED.
12. UNLESS INCLUDED AS PART OF MANUFACTURED ASSEMBLY, THREADED RODS AND U-BOLTS SHALL BE HOT-DIPPED GALVANIZED STEEL. IN SOME CASES DUE TO MANUFACTURED PART AVAILABILITY, THREADED RODS AND U-BOLTS MAY BE STAINLESS STEEL. IN THIS CASE, THEY MUST CONFORM TO ASTM A193, CLASS I, GRADE B8 (AISI TYPE 304). WASHERS SHALL CONFORM TO ASTM A240, TYPE 302. NUTS SHALL CONFORM TO ASTM A194 (AASHTO M292), GRADE 8F (AISI TYPE 303). ALL THREADED RODS AND U-BOLTS TO BE DOUBLE NUTTED. MATERIAL FOR STRUCTURAL STEEL, ANGLES, ETC. SHALL BE A36 AND SHALL BE HOT-DIPPED GALVANIZED ACCORDING TO ASTM 4123.
13. CONDUIT OUTLET BODY WITH COVER SHALL BE MALLEABLE IRON WITH TRIPLE COAT FINISH OR EPOXY POWDER COATED ALUMINUM. OUTLET BODY SHALL BE SEALED TIGHT WITH NEOPRENE GASKETS.
14. CABLE STRAIN RELIEF STARTS AT THE 12"x12"x6" JUNCTION BOX. BELOW THE JUNCTION BOX, C-CONDULETS SHALL BE UTILIZED EVERY 30'-0". THE CONTRACTOR IS RESPONSIBLE FOR UTILIZING STRAIN RELIEF TECHNIQUES IN THE CONDULETS AND JUNCTION BOX. FOR EXAMPLE, A WEAVED STRAIN RELIEF GRIP CAN BE UTILIZED OR WEDGES. THE CONTRACTOR WILL COORDINATE THIS EFFORT WITH THE ENGINEER AND THE ILLINOIS TOLLWAY TOWER CREW. JUNCTION BOX SHALL HAVE WEEP HOLES IN BOTTOM TO ALLOW MOISTURE TO BLEED OFF. JB SHALL HAVE A NON-CORROSIVE TERMINAL STRIP SO IT CAN BE USED AS A TRANSITION POINT FOR CABLING.
15. ALL NECESSARY MOUNTING HARDWARE AND BRACKETS NECESSARY TO ATTACH THE EQUIPMENT, RACEWAYS AND PULL BOXES TO THE TOWER SHALL BE PRE-MANUFACTURED AND NOT BE BUILT IN THE FIELD WITH INDIVIDUAL COMPONENTS.
16. CAMERA ATTACHMENTS TO TOWER LEG SHALL BE AT MINIMUM OF 2 LOCATIONS UTILIZING UNIVERSAL SADDLE MOUNTS OR WELDED PIPE TO PIPE CLAMPS DEPENDING ON THE TOWER TYPE. CONTRACTOR TO DETERMINE PROPER SIZE. U-BOLTS WILL BE REQUIRED. THE GOOSE NECK MOUNT TO THE TOWER SHALL BE SET PLUMB SO AS TO PROVIDE A PLUMB CAMERA INSTALLATION.
17. ALL WORK WILL REQUIRE CLOSE COORDINATION WITH ILLINOIS TOLLWAY STAFF AND THE ENGINEER. THIS INCLUDES A PRE-INSTALLATION MEETING WITH ILLINOIS TOLLWAY STAFF AND ENGINEER.
18. NOT USED.
19. ALL CONDUIT CONNECTIONS SHALL BE SEALED WITH TAPE AS PER ILLINOIS TOLLWAY TOWER CREW INSTRUCTIONS.
20. NOT USED.
21. NOT USED.
22. NOT USED.
23. NOT USED.



ITS DETAILS TOWER MOUNT CAMERA DETAILS

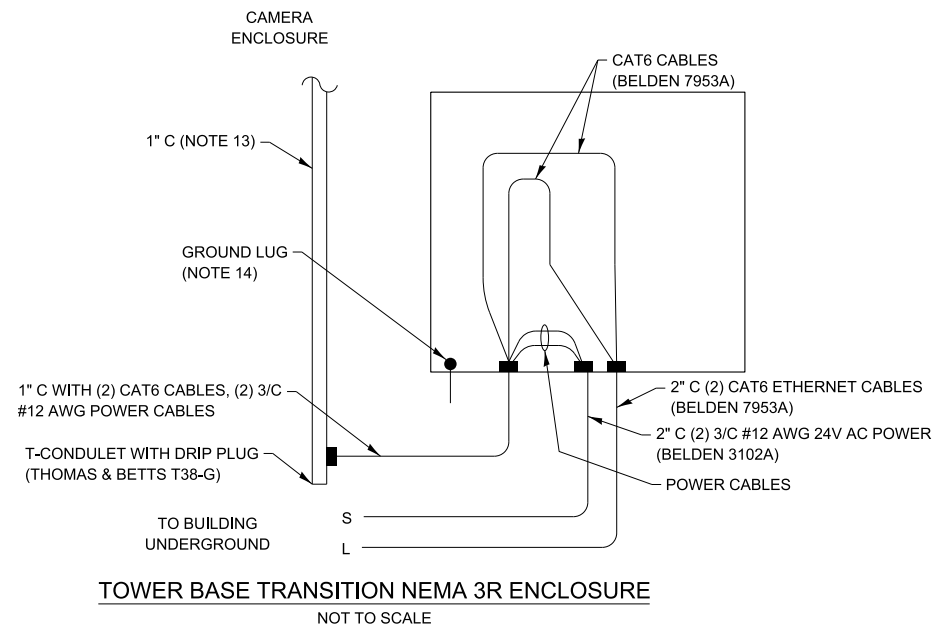

TOWER BASE TRANSITION NEMA 3R ENCLOSURE
NOT TO SCALE

ABBREVIATIONS:

AISC	AMERICAN INSTITUTE OF STEEL CONSTRUCTION
ASCE	AMERICAN SOCIETY OF CIVIL ENGINEERS
TIA	TELECOMMUNICATION INDUSTRY ASSOCIATION
RGS	RIGID GALVANIZED STEEL
JB	JUNCTION BOX

NOTES:

1. NOT USED.
2. CAMERA MUST BE GROUNDED IN HOUSING.
3. ALL EQUIPMENT MUST BE CONNECTED TO A COMMON GROUND. GROUND CABLES SHALL BE GREEN INSULATED TYPE RHW CONDUCTORS. ANY GROUND CONDUCTORS THAT ARE BURIED SHALL BE SOLID COPPER TINNED.
4. NOT USED.
5. NOT USED.
6. ALL CONDUIT CONNECTIONS SHALL BE SEALED WITH TAPE PER ILLINOIS TOLLWAY TOWER CREW INSTRUCTIONS.
7. NOT USED.
8. NOT USED.
9. NOT USED.
10. HD IP CAMERA WILL USE A SINGLE CAT6 CABLE TO EACH CAMERA.
11. NOT USED.
12. CAMERA TRANSITION NEMA 3R STAINLESS STEEL JUNCTION BOX IS USED TO TRANSITION TO THE 2 CAMERAS. ENCLOSURE MUST MOUNT SECURELY TO TOWER AT TWO POINTS.
13. LOOP A MINIMUM OF 3FT OF CAT 6 INSIDE CAMERA TRANSITION ENCLOSURE.
14. NOT USED.

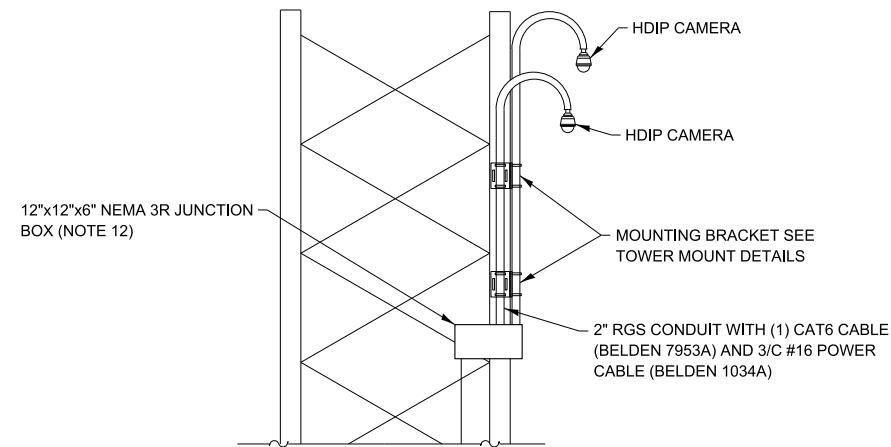

SEE TOWER MOUNT DETAILS FOR DETAILS ON CLAMP KITS FOR TRANSMISSION LINES AND 1" CAMERA CONDUIT ALONG WITH CONDULETS USED FOR STRAIN RELIEF

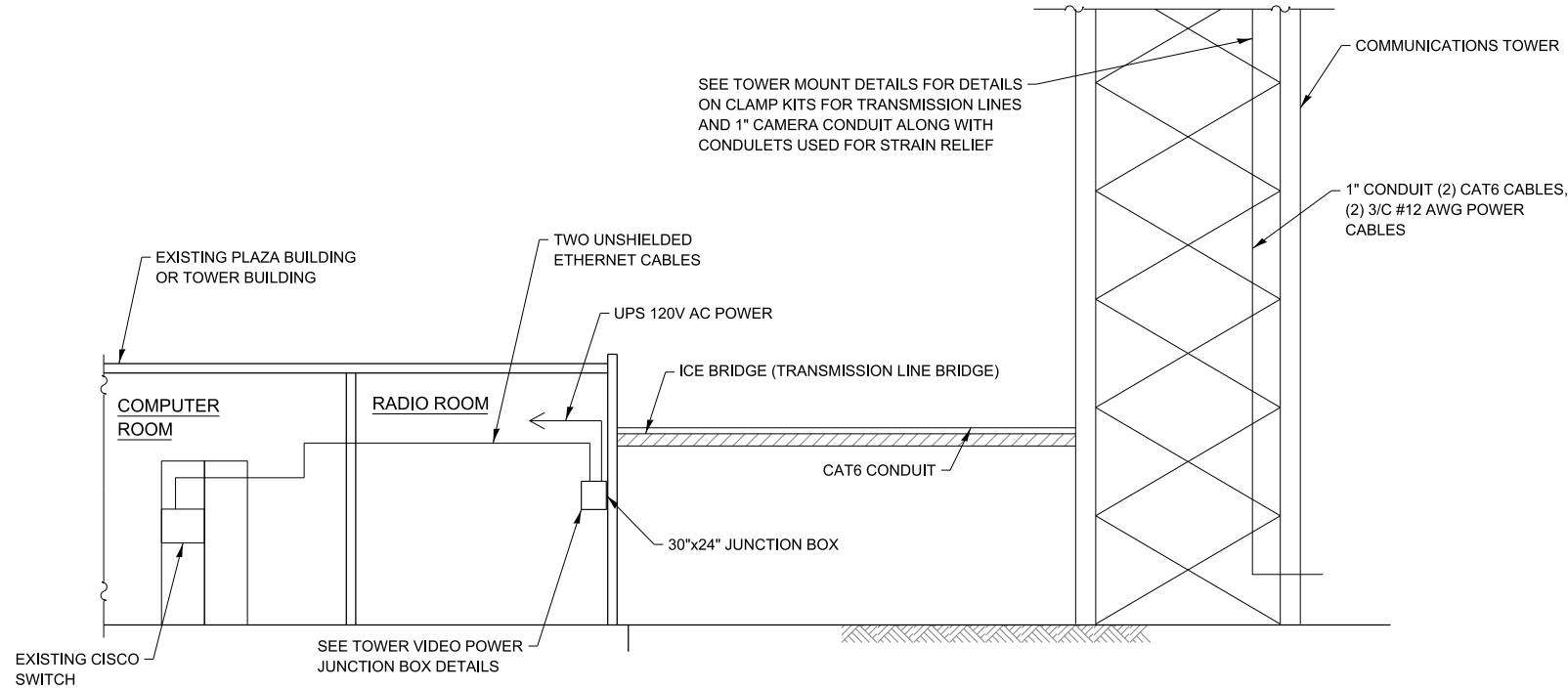

TOWER MOUNT CAMERA ASSEMBLY
NOT TO SCALE

NOTE TO DESIGNER

THIS BASE SHEET SHOWS TYPICAL CONSTRUCTION BUT IT IS **NOT** A STANDARD DRAWING. IT REQUIRES COMPLETION BY THE DESIGNER PRIOR TO INSERTION INTO A CONTRACT. MICROSTATION FILES AND THE "CADD STANDARDS MANUAL" ARE AVAILABLE ON THE ILLINOIS TOLLWAY WEBSITE. THE DESIGNER SHALL ACCEPT THE RESPONSIBILITY OF THE DESIGN OF THIS SHEET UPON ITS COMPLETION AND INSERTION INTO A CONTRACT. ALL "NOTE TO DESIGNER" BOXES SHALL BE REMOVED BY THE DESIGNER PRIOR TO INSERTION OF THE SHEET INTO THE PLAN SET.

NOTE TO DESIGNER

ROUTING OF CONDUIT AND CABLES TO PLAZA/TOWER BUILDING SHALL BE SHOWN FOR EACH INSTALLATION OCCURRENCE DEPICTING ACTUAL CONDITIONS. INSTALLATION AND ROUTING OF EQUIPMENT AND CABLES SHALL BE SHOWN IN PLAN VIEW FORMAT AS WELL AS DESCRIBE THE LOCATION AND POSITION OF WALL MOUNT, RACK MOUNT AND CABLE TRAY POSITIONS WITHIN THE PLAZA/TOWER BUILDING. CISCO SWITCH PORTS TO BE USED SHALL BE IDENTIFIED.

MAXIMUM OF 300' LENGTH FOR CAT 6 CABLE TO CAMERA. IF LENGTH IS EXCEEDED, REDUCE MOUNTING HEIGHT. MAXIMUM HEIGHT OF THE 2 CCTV IS 100 FEET FROM THE BASE OF THE TOWER



ITS DETAILS TOWER CAMERA ASSEMBLY 300' CAT OR LESS

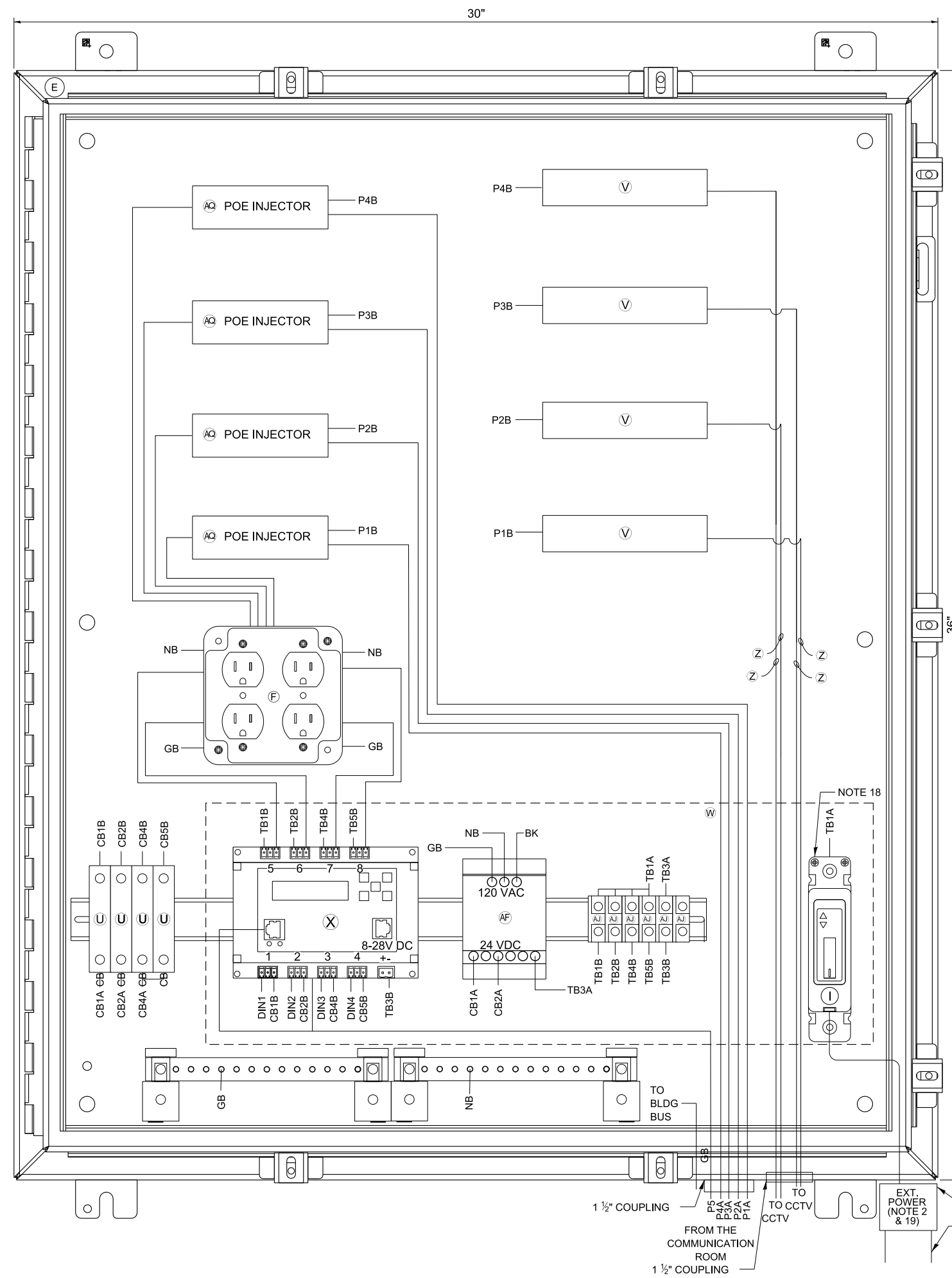

ITEM DESCRIPTION

- (A) NOT USED
- (B) NOT USED
- (C) NOT USED
- (D) TWO (2) GROUNDING BAR SYSTEM HOFFMAN/PGS2K. BONDED OR SEPARATED AS REQUIRED.
- (E) NEMA 4X STAINLESS STEEL, 36"H X 30"W X 12"D ENCLOSURE WITH 33"x27" PANEL, HOFFMAN/A36H3012SS6LP & A36P30
- (F) ONE QUAD 120V RECEPTACLE
- (G) NOT USED
- (H) NOT USED
- (I) 120V, 1P, 30A CIRCUIT BREAKER WITH TERMINAL SHIELD EATON
- (J) NOT USED
- (K) NOT USED
- (L) NOT USED
- (M) NOT USED
- (N) NOT USED
- (O) NOT USED
- (P) NOT USED
- (Q) NOT USED
- (R) NOT USED
- (S) NOT USED
- (T) NOT USED
- (U) 5A CIRCUIT BREAKER, ALLEN BRADLEY/1492-SPM1B050
- (V) AXIS SURGE SUPPRESSOR T8061, MOUNTED ON COMMON DIN RAIL AND GROUNDED
- (W) CLEAR PLEXIGLASS SAFETY COVER PANEL ENCOMPASSING ITEMS I, X, AF AND AJ (THE INSTALLER SHALL PERMANENTLY AFFIX A LABEL STATING "DANGER 480 VAC" OR "DANGER 240 VAC" OR "DANGER 120 VAC" FOR VOLTAGE AS FIELD CONDITIONS WARRANT.)
- (X) POWER CONTROLLER, 8-CHANNEL DIN ETHERNET RELAY DIGITAL LOGGERS/DIN 4
- (Y) NOT USED
- (Z) CATEGORY 6 CABLE, 23AWG, OUTDOOR RATED CABLE BELDEN/7953A
- (AA) NOT USED
- (AB) NOT USED
- (AC) NOT USED
- (AD) NOT USED
- (AE) NOT USED
- (AF) AC/DC POWER SUPPLY, 24VDC WAVETRONIX - CLICK-204
- (AG) NOT USED
- (AH) NOT USED
- (AI) NOT USED
- (AJ) TERMINAL BLOCK, ALLEN BRADLEY/1492-CD8
- (AP) #10 AWG
- (AQ) POE INJECTOR AXIS T8154 60W MIDSPAN 120VAC

NOTES:

1. ALL POWER WIRING SHALL BE RHH/RHW WITH WIRE TERMINALS OR TINNED.
2. CONTRACTOR TO VERIFY CORRECT TRANSFORMER TAPS ARE USED BASED ON INCOMING POWER SOURCE.
3. ALL CABLES AND EQUIPMENT SHALL BE PROPERLY DRESSED AND LABELED. ALL CONDUITS SHALL BE PROPERLY PLUGGED WITH DUCT SEAL PUTTY (RAINBOW TECHNOLOGIES OR EQUIVALENT).
4. EACH 120VAC OUTLET, OR (ITEM F, & AF) SHALL BE FED FROM A SEPARATE POWER CIRCUIT.
5. MOUNT ITEMS U, X, AF & AJ ON A 21 INCH CONTINUOUS SECTION OF DIN RAIL.
6. ALL BREAKERS SHALL BE LABELED (e.g. CAMERA-AC, CAMERA-DC, DIN RELAY-AC, DIN RELAY-DC, CELL MODEM-AC ETC.).
7. USE THE MOUNTING TABS ON THE IP RELAY UNIT TO MOUNT THE UNIT DIRECTLY TO THE DIN RAIL. REFER TO THE IP RELAY WIRING TABLE FOR WIRING DETAILS.
8. IP RELAY IS USED TO CONTROL POWER TO THE CAMERAS AND DETECTORS. ALL 120VAC CONNECTIONS ON ITEM X SHALL BE PROTECTED.
9. DIN RAIL SHALL BE INSTALLED AS ILLUSTRATED ON DRAWING. DIN RAIL SHALL BE GROUNDED TO THE GROUND BUS.
10. BOND NEUTRAL AND GROUND BUSES TOGETHER, WHEN REQUIRED. TIE THE ENCLOSURE INTO THE GROUND BUS.
11. THE PLEXIGLASS PANEL DENOTED BY THE DASHED LINE SHALL BE ATTACHED TO THE BACKPLATE WITH 4 MOUNTING STUDS.
12. ALL INTERNAL ENCLOSURE ROUTED AND TERMINATED CAT6 CABLE SHALL BE TEMPERATURE RATED.
13. ALL INTERNAL 24VAC, 120VAC AND ANY DC VOLTAGE POWER FEEDS USE #16 AWG CABLE.
14. PROVIDE WINDOW IN PMMA SHIELD FOR ACCESS TO BREAKER, MOUNT BREAKER FLUSH WITH PMMA SHIELD USING MOUNTING BRACKET.
15. 120V POWER COMES FROM THE BUILDING CIRCUIT PANEL.
16. WIFI COMMUNICATION SHALL BE DISABLED ON DIN ETHERNET RELAY.

NOTE TO DESIGNER
 THE CAMERA CONTROLS ARE LOCATED IN THE VIDEO POWER JUNCTION BOX IN THE PLAZA COMMUNICATION ROOM.

NOTE TO DESIGNER
 THIS CONFIGURATION IS FOR USE WHERE THE POWER FROM THE COMMUNICATION BUILDING IS 120V AND THE DISTANCE FROM THE SWITCH INSIDE THE BUILDING TO THE CAMERA IS LESS THAN 300'. THIS CONFIGURATION REQUIRES THE ETHERNET RELAY TO BE INSTALLED INSIDE THE COMMUNICATION BUILDING.

NOTE TO DESIGNER
 THIS BASE SHEET SHOWS TYPICAL CONSTRUCTION BUT IT IS NOT A STANDARD DRAWING. IT REQUIRES COMPLETION BY THE DESIGNER PRIOR TO INSERTION INTO A CONTRACT. MICROSTATION FILES AND THE "CADD STANDARDS MANUAL" ARE AVAILABLE ON THE ILLINOIS TOLLWAY WEBSITE. THE DESIGNER SHALL ACCEPT THE RESPONSIBILITY OF THE DESIGN OF THIS SHEET UPON ITS COMPLETION AND INSERTION INTO A CONTRACT. ALL "NOTE TO DESIGNER" BOXES SHALL BE REMOVED BY THE DESIGNER PRIOR TO INSERTION OF THE SHEET INTO THE PLAN SET.

**CABINET WIRING DIAGRAM
TOWER MOUNTED CCTV ITS
ASSEMBLY**

VERSION: 2024-03 STANDARD: M-ITS-1503 SHEET: 1 OF 1

