

<b>Illinois Tollway Base Sheet Revisions</b>
--

<b>Section M Base Sheet Drawings</b>	
<b>Drawing</b>	<b>Modification Summary</b>
	<b>Effective: 03-01-2024</b>
<b>Drainage (DRN)-Series 600</b>	
<b>M-DRN-601</b>	<b>SLOPE DRAIN</b>
	Added callouts for the structures that are paid for separately. Added columns in the schedule for "U/S Drainage Structure No.", "D/S Drainage Structure No." and "Pay Item."
<b>M-DRN-603</b>	<b>ARTICULATED CONCRETE BLOCK REVETMENT SYSTEM</b>
	Revised Note to Designer Number 4.
<b>M-DRN-606</b>	<b>EXPOSED MOMENT SLAB WITH DRAINAGE STRUCTURE</b>
	Renamed the base sheet from "Section through Moment Slab with Drainage Structure Detail" to "Exposed Moment Slab with Drainage Structure." Revised the display of the load transfer system and soil reinforcement in Section A-A. Added callouts for 1/2" Preformed Joint Filler and sealant in Section A-A.
<b>M-DRN-607</b>	<b>NOISE ABATEMENT WALL DRAINAGE DETAILS (ROADWAY SIDE)</b>
	Added clearance requirement between catch basin and drilled shaft.

 New Sheet

 Retired Standard

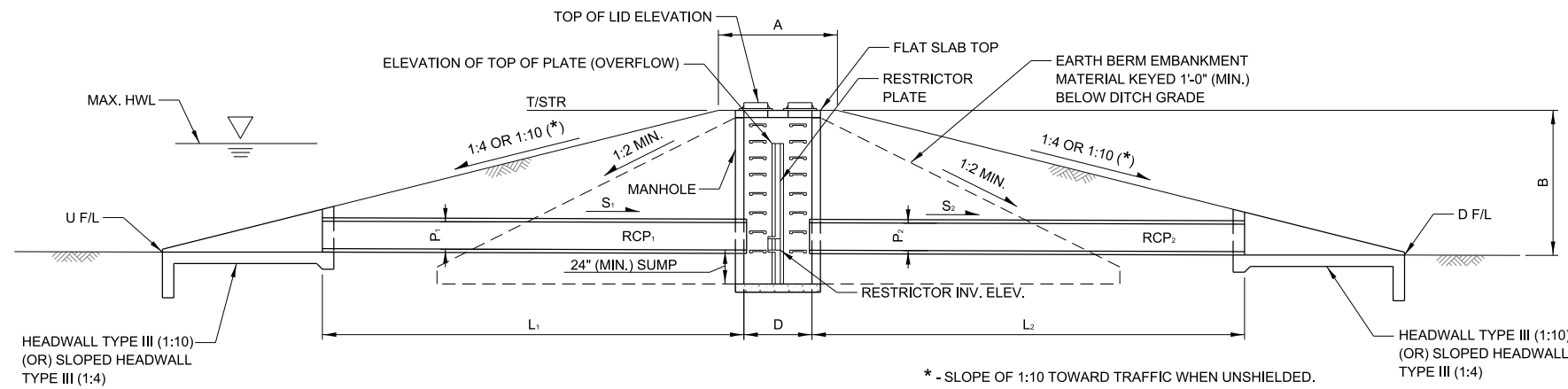

PROFILE VIEW

DESIGN ELEMENTS	UNITS	VALUES
DRAINAGE AREA	X (ACRES)	
STORAGE VOLUME	V (CU. YD.)	
CHECK DAM TOP WIDTH	A (FEET)	
CHECK DAM HEIGHT	B (FEET)	
MANHOLE	D (DIAMETER)	
MANHOLE-GRATE	TYPE	
HORIZONTAL PIPE (RCP) <sub>1</sub>	P <sub>1</sub> (DIAMETER)	
HORIZONTAL PIPE (RCP) <sub>1</sub>	L <sub>1</sub> (FEET)	
HORIZONTAL PIPE (RCP) <sub>1</sub>	S <sub>1</sub> (SLOPE)	
HORIZONTAL PIPE (RCP) <sub>2</sub>	P <sub>2</sub> (DIAMETER)	
HORIZONTAL PIPE (RCP) <sub>2</sub>	L <sub>2</sub> (FEET)	
HORIZONTAL PIPE (RCP) <sub>2</sub>	S <sub>2</sub> (SLOPE) (%)	
RESTRICTOR PLATE-DETAIL	SHAPE	
2-YEAR RELEASE RATE	CFS	
100-YEAR RELEASE RATE	CFS	
HEADWALL TYPE III (1:10)	PIPE DIAMETER	
SLOPED HEADWALL TYPE III (1:4)	PIPE DIAMETER	
HIGH WATER ELEVATION	HWL (FEET)	
TOP OF STRUCTURE ELEVATION	T/STR (FEET)	
UPSTREAM FLOWLINE	U F/L (FEET)	
DOWNSTREAM FLOWLINE	D F/L (FEET)	
2-YEAR ORIFICE INVERT ELEV.	(FEET)	
100-YEAR ORIFICE INVERT ELEV.	(FEET)	

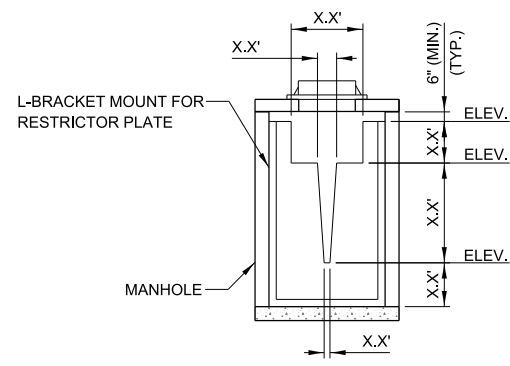

RESTRICTOR PLATE DETAIL

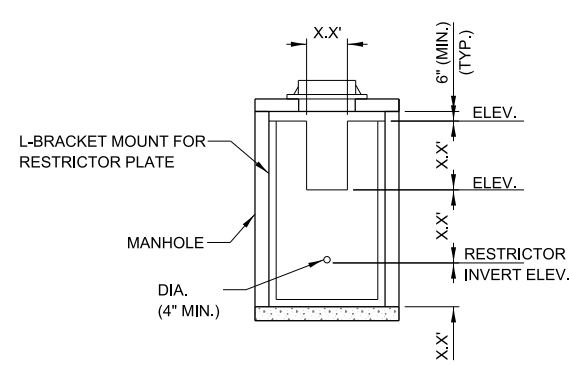

RESTRICTOR PLATE DETAIL

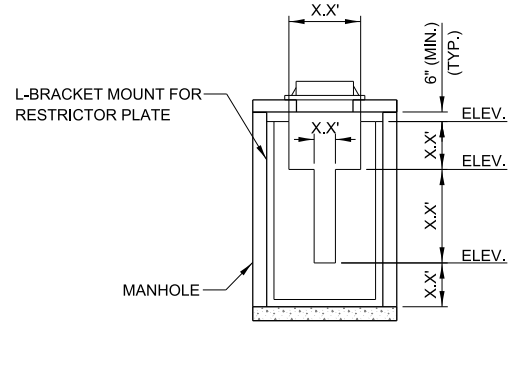

RESTRICTOR PLATE DETAIL

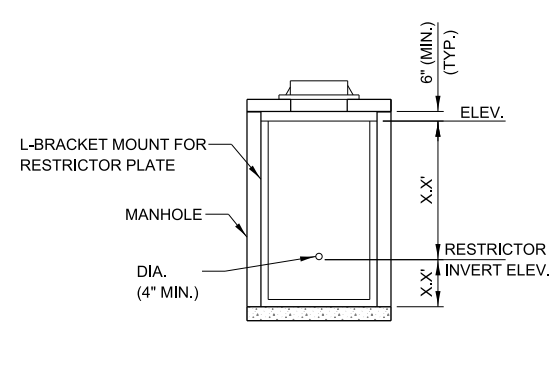

RESTRICTOR PLATE DETAIL

SAMPLE RESTRICTOR PLATE DETAILS

OUTLET CONTROL STRUCTURE (CHECK DAM)

NOTES:

1. ALL SLOPES ARE EXPRESSED AS UNITS OF VERTICAL DISPLACEMENT TO UNITS OF HORIZONTAL DISPLACEMENT. (V:H).
2. THE CONTRACTOR HAS THE OPTION TO USE A CONCRETE RESTRICTOR PLATE THAT IS PRECAST WITHIN THE DRAINAGE STRUCTURE.

**NOTE TO DESIGNER**  
 THIS BASE SHEET SHOWS TYPICAL CONSTRUCTION BUT IT IS NOT A STANDARD DRAWING. IT REQUIRES COMPLETION BY THE DESIGNER PRIOR TO INSERTION INTO A CONTRACT. MICROSTATION FILES AND THE "CADD STANDARDS MANUAL" ARE AVAILABLE ON THE ILLINOIS TOLLWAY WEBSITE. THE DESIGNER SHALL ACCEPT THE RESPONSIBILITY OF THE DESIGN OF THIS SHEET UPON ITS COMPLETION AND INSERTION INTO A CONTRACT. ALL "NOTE TO DESIGNER" BOXES SHALL BE REMOVED BY THE DESIGNER PRIOR TO INSERTION OF THE SHEET INTO THE PLAN SET.

**NOTE TO DESIGNER**  
 1. DSE SHALL DESIGN STEEL ANGLE BOLTS AND FASTENERS FOR THE STEEL RESTRICTOR PLATES. DETAILS ARE TO BE PROVIDED ON THIS SHEET.



OUTLET CONTROL STRUCTURE CHECK DAM DETAILS

**NOTE TO DESIGNER**

THIS BASE SHEET SHOWS TYPICAL CONSTRUCTION BUT IT IS NOT A STANDARD DRAWING. IT REQUIRES COMPLETION BY THE DESIGNER PRIOR TO INSERTION INTO A CONTRACT. MICROSTATION FILES AND THE "CADD STANDARDS MANUAL" ARE AVAILABLE ON THE ILLINOIS TOLLWAY WEBSITE. THE DESIGNER SHALL ACCEPT THE RESPONSIBILITY OF THE DESIGN OF THIS SHEET UPON ITS COMPLETION AND INSERTION INTO A CONTRACT. ALL "NOTE TO DESIGNER" BOXES SHALL BE REMOVED BY THE DESIGNER PRIOR TO INSERTION OF THE SHEET INTO THE PLAN SET.

**NOTES TO DESIGNER**

- FOR SLOPES 1:3 OR FLATTER, PLACE A MINIMUM OF ONE CONCRETE COLLAR AT THE MIDDLE PIPE JOINT IF SLOPE DRAIN LENGTH  $\leq$  80 FEET. IF SLOPE DRAIN LENGTH  $>$  80 FEET, PLACE CONCRETE COLLARS AT A MAXIMUM 40 FOOT SPACING.
- FOR SLOPES STEEPER THAN 1:3, PLACE CONCRETE COLLARS AT A MAXIMUM 20 FOOT SPACING.
- THE AIR VENT IS REQUIRED WHEN  $HW/D \geq 0.8$  TO PREVENT CAVITATION.

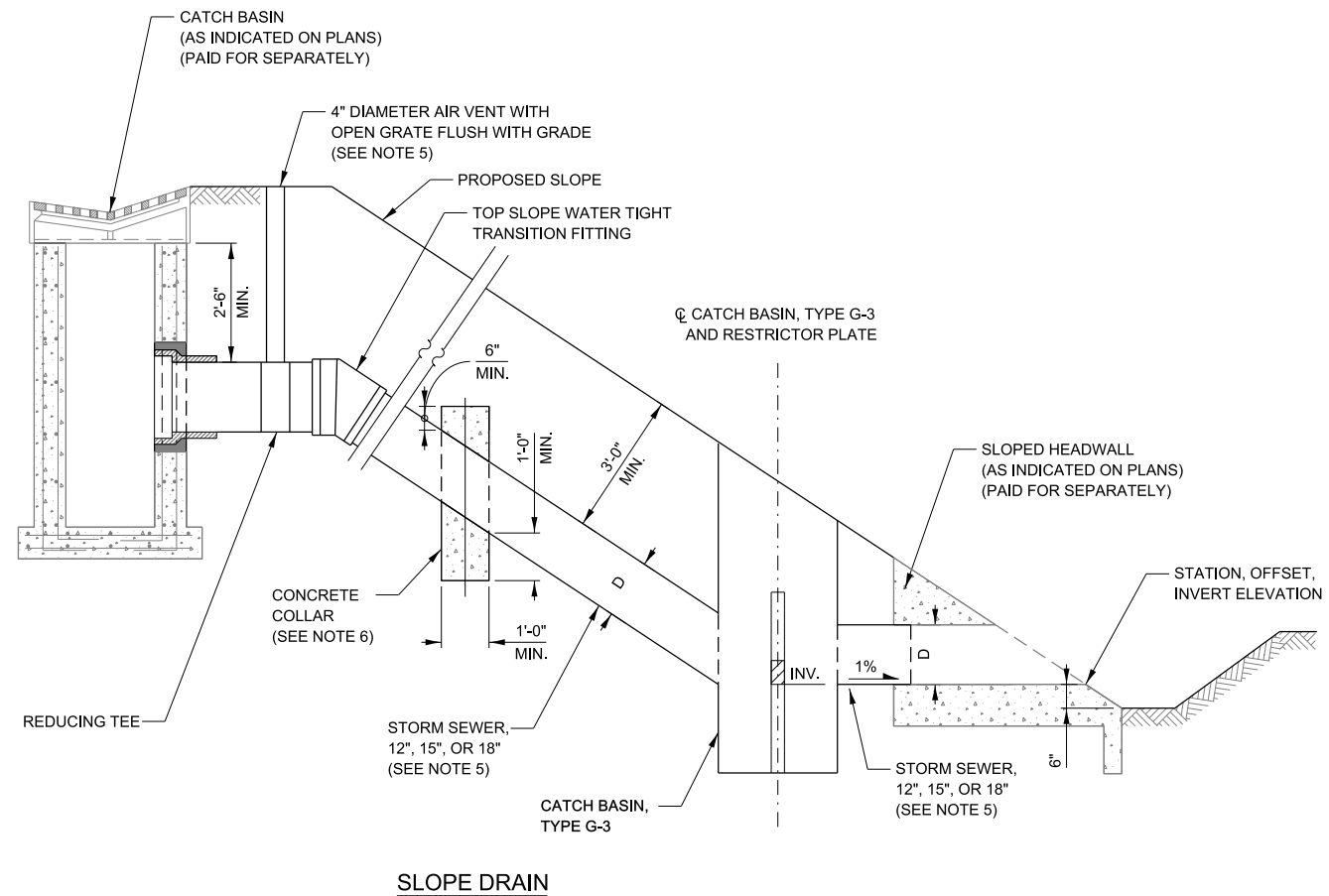

**SLOPE DRAIN**

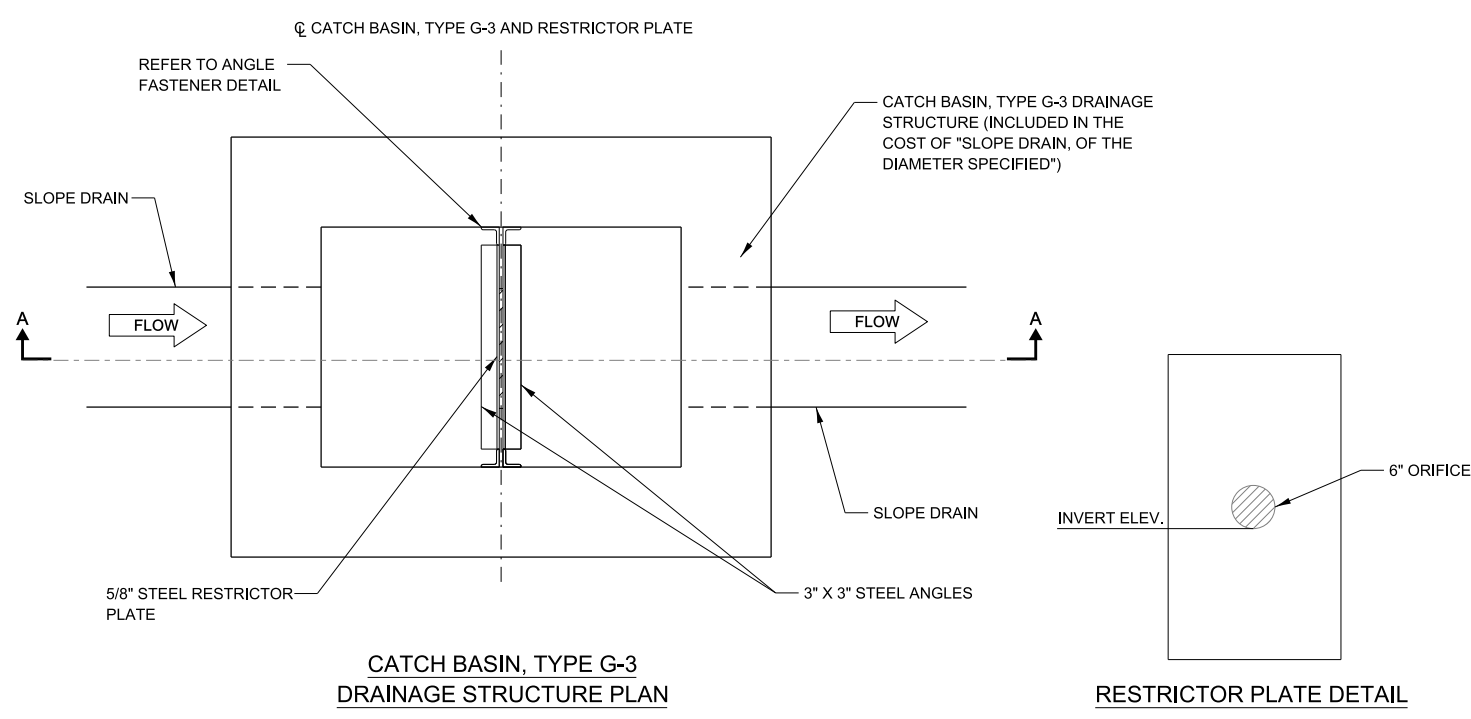

**CATCH BASIN, TYPE G-3 DRAINAGE STRUCTURE PLAN**

**RESTRICTOR PLATE DETAIL**

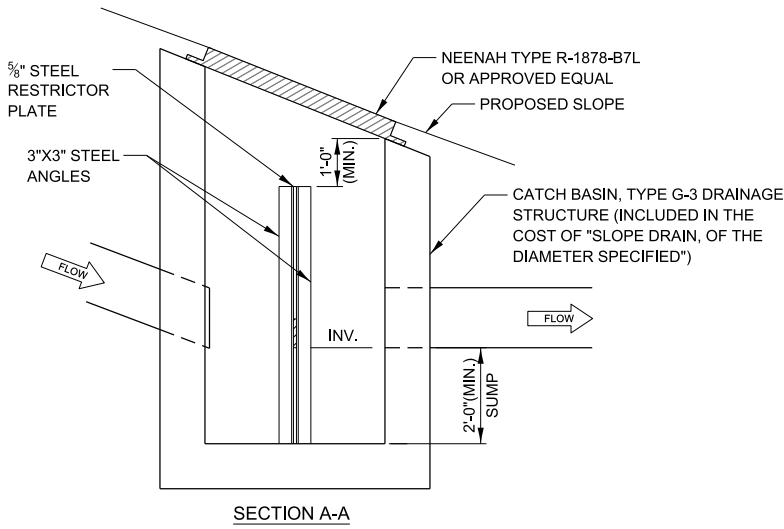

**SECTION A-A**

**NOTES:**

- THE STORM SEWERS, CONCRETE COLLAR, CATCH BASIN, TYPE G-3, RESTRICTOR PLATE, ANGLES AND HARDWARE AND FRAME AND GRATE, SHALL BE INCLUDED IN THE COST OF SLOPE DRAIN OF THE DIAMETER SPECIFIED.
- SEE ILLINOIS TOLLWAY STANDARD B8 FOR DIMENSION OF CATCH BASIN, TYPE G-3 STRUCTURE.
- THE TOP OF THE CATCH BASIN, TYPE G-3 SHALL BE CUT IN THE FIELD TO MATCH THE PROPOSED EMBANKMENT SLOPE.
- THE CONTRACTOR HAS THE OPTION TO USE A CONCRETE RESTRICTOR PLATE THAT IS PRECAST WITHIN THE DRAINAGE STRUCTURE.
- PIPE MATERIAL SHALL BE HDPE WITH SMOOTH INTERIOR OR EPOXY COATED CORRUGATED GALVANIZED STEEL PIPE OF THE SIZE SPECIFIED.
- THE MINIMUM CONCRETE COLLAR WIDTH SHALL BE  $D + 24"$ .
- ALL STEEL ANGLES AND PLATES SHALL BE GALVANIZED AFTER FABRICATION.
- STEEL PLATE AND ANGLES SHALL BE IN ACCORDANCE WITH AASHTO M 270 GRADE 36.
- ANGLES SHALL BE 3" X 3" X 3/8".
- VERTICAL ANGLES SHALL EXTEND FROM THE BOTTOM OF THE CATCH BASIN TO THE TOP OF THE RESTRICTOR PLATE.
- HORIZONTAL ANGLES SHALL EXTEND FROM VERTICAL ANGLE TO VERTICAL ANGLE.

SLOPE DRAIN PIPE NO.	DIAMETER (D) (IN)	LENGTH (FT)	CONCRETE COLLAR			CATCH BASIN, TYPE G-3			INV.	TOP OF RESTRICTOR PLATE ELEVATION	U/S DRAINAGE STRUCTURE NO.	D/S DRAINAGE STRUCTURE NO.	PAY ITEM
			STATION	OFFSET (FT)	OFFSET (LT/RT)	STATION	OFFSET (FT)	OFFSET (LT/RT)					

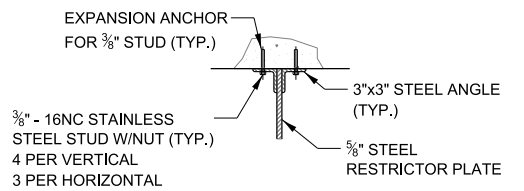

**ANGLE FASTENER DETAIL**

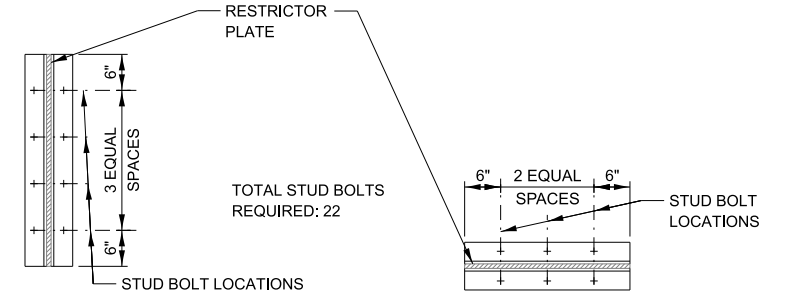

**STEEL ANGLE BOLTING DETAILS**



**SLOPE DRAIN**

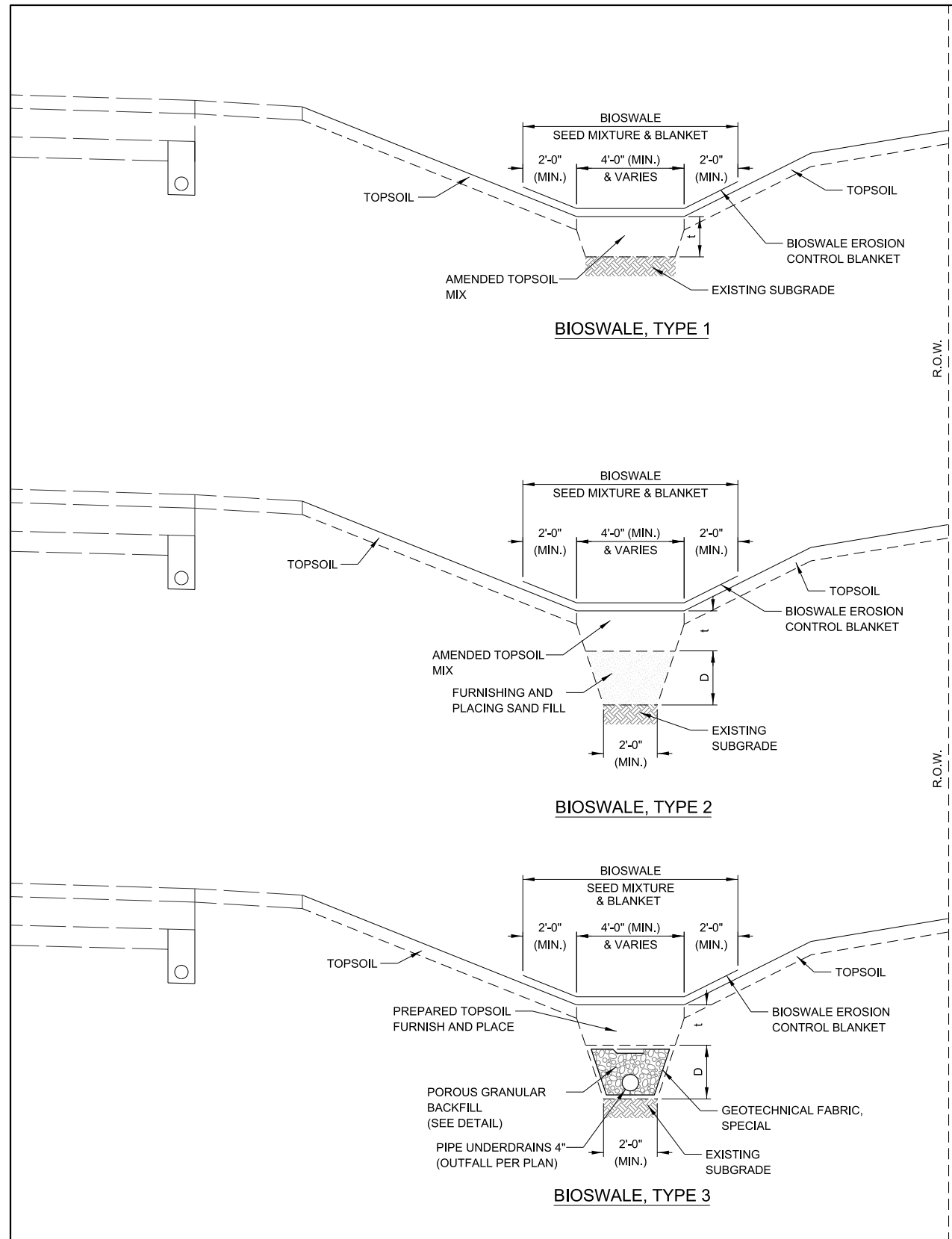

BIOSWALE NO.	BIOSWALE TYPE	BEGIN STATION	END STATION	PREP/AMENDED TOPSOIL THICKNESS (t)	BIOSWALE BASE (D)

**NOTE TO DESIGNER**

THIS BASE SHEET SHOWS TYPICAL CONSTRUCTION BUT IT IS NOT A STANDARD DRAWING. IT REQUIRES COMPLETION BY THE DESIGNER PRIOR TO INSERTION INTO A CONTRACT. MICROSTATION FILES AND THE "CADD STANDARDS MANUAL" ARE AVAILABLE ON THE ILLINOIS TOLLWAY WEBSITE. THE DESIGNER SHALL ACCEPT THE RESPONSIBILITY OF THE DESIGN OF THIS SHEET UPON ITS COMPLETION AND INSERTION INTO A CONTRACT. ALL "NOTE TO DESIGNER" BOXES SHALL BE REMOVED BY THE DESIGNER PRIOR TO INSERTION OF THE SHEET INTO THE PLAN SET.

**NOTES TO DESIGNER**

- ALL PIPE UNDERDRAINS SHALL EITHER OUTLET AT GRADE OR TO A DRAINAGE STRUCTURE AND GRAVITY DRAIN.
- ALL PIPE UNDERDRAINS SHALL HAVE AN INLET ON THE UPSTREAM END AND EVERY 500' MINIMUM TO SERVE AS A CLEAN-OUT.

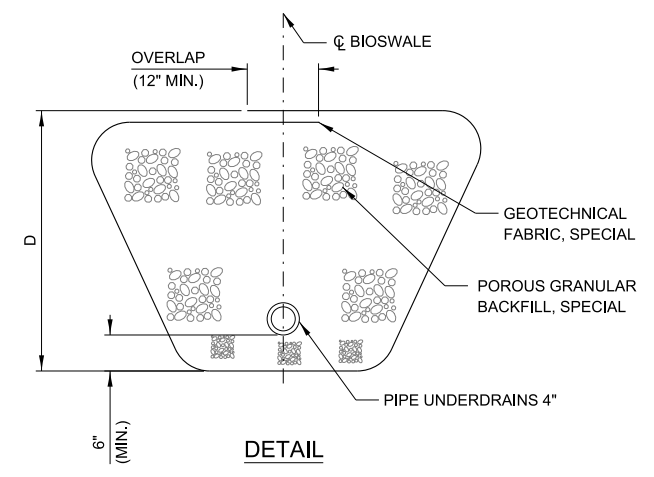

**NOTES:**

- THE ENDS OF THE PIPE UNDERDRAIN OUTLET AT GRADE SHALL BE PROTECTED BY A PERMANENT RODENT SHIELD IN ACCORDANCE WITH STANDARD B24.

**Illinois Tollway**

**BIOSWALE**

VERSION: 2016-03	STANDARD: M-DRN-602	SHEET: 1 OF 1
---------------------	------------------------	------------------

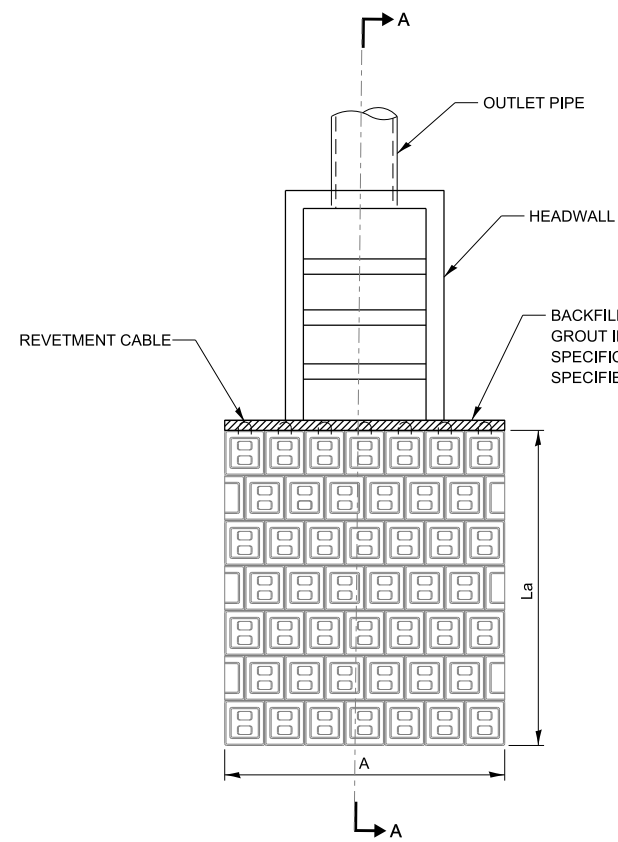

**OUTLET PROTECTION DETAIL**  
NOT TO SCALE

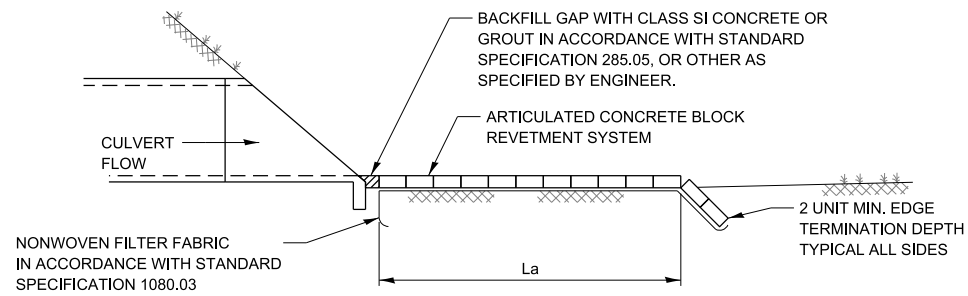

**SECTION A-A (NO DEFINED CHANNEL)**  
NOT TO SCALE

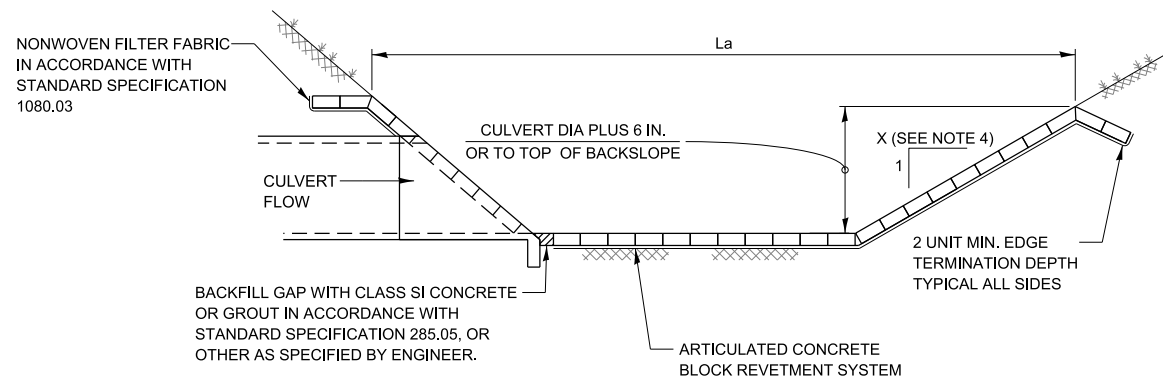

**SECTION A-A (DEFINED CHANNEL)**  
NOT TO SCALE

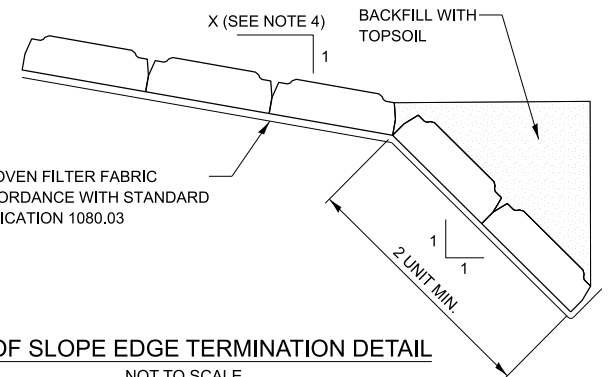

**TOE OF SLOPE EDGE TERMINATION DETAIL**  
NOT TO SCALE

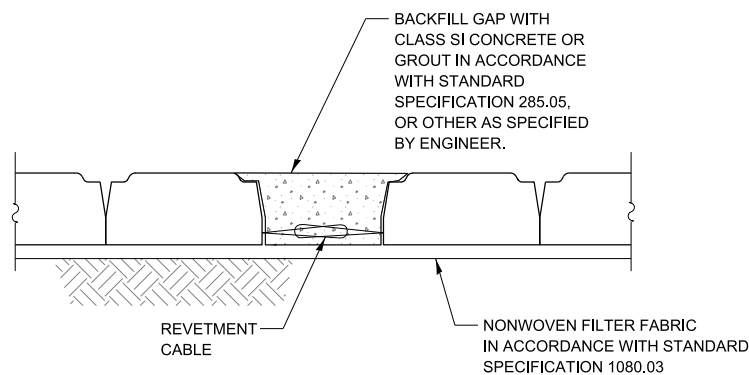

**TYPICAL MAT TO MAT**  
NOT TO SCALE

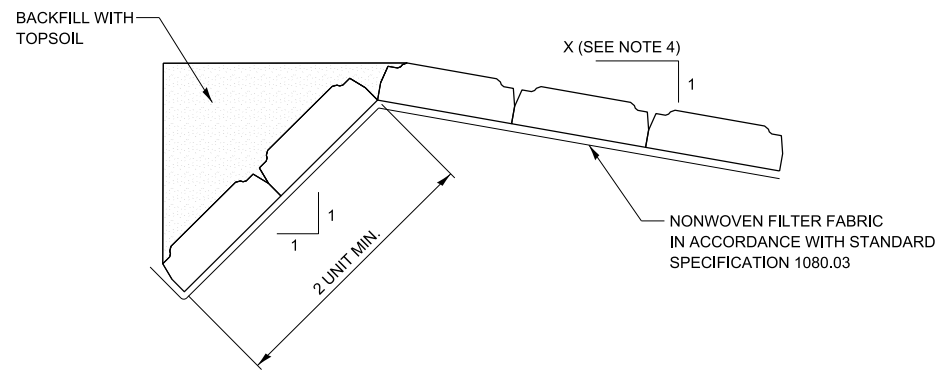

**TOP OF SLOPE EDGE TERMINATION DETAIL**  
NOT TO SCALE

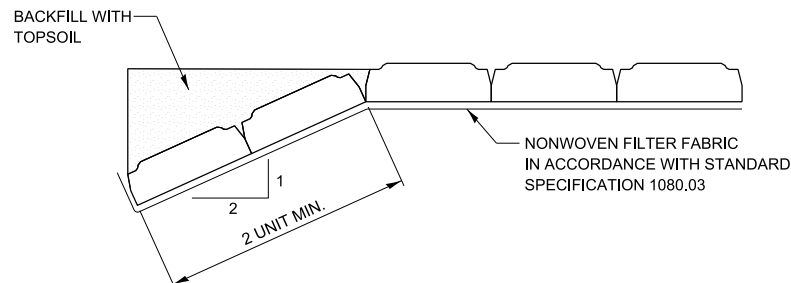

**GROUND EDGE TERMINATION DETAIL**  
NOT TO SCALE

**NOTES:**

1. EACH BLOCK SHALL INCORPORATE INTERLOCKING SURFACES THAT MINIMIZE LATERAL DISPLACEMENT OF THE BLOCKS WITHIN THE MATS WHEN THEY ARE LIFTED BY THE LONGITUDINAL REVETMENT CABLES. HAND PLACED INTERLOCKING BLOCKS ARE ALSO ACCEPTABLE.
2. THE TOP OF BLOCK ELEVATION SHALL BE AT OR BELOW THE DITCH FLOW LINE, OR FINISHED SURFACE.
3. PAY LENGTH IS EQUAL TO DIMENSION "La" PLUS THE TOTAL ESTIMATED LENGTH OF THE BURIED PORTION OF THE BLOCKS. PAY WIDTH IS EQUAL TO DIMENSION "A" PLUS THE TOTAL ESTIMATED WIDTH OF THE BURIED PORTION OF THE BLOCKS.
4. THE MAXIMUM BANK SLOPE FOR AN ACBRS SHALL BE 1:2 (V:H).

STRUCTURE NO.	D (IN.)	La (FT.)	A (FT.)	PAY LENGTH (FT.) (SEE NOTE 3)	PAY WIDTH (FT.) (SEE NOTE 3)	BLOCK TYPE	MAT CONFIGURATION	ACBRS (SQ YD)

- NOTES TO DESIGNER**
1. THE AREA OF MEASURE WILL INCLUDE THE COMPLETE INSTALLED MATS, INCLUDING BOTH VISIBLE AREA AND THE BURIED EDGE PORTIONS OF THE INSTALLATION WHICH ARE NOT VISIBLE UPON PROJECT COMPLETION (EDGE TERMINATION).
  2. THE STANDARD MAT DIMENSIONS ARE 8 FT BY 12 FT AND 8 FT BY 20 FT. THE DESIGNER SHOULD SPECIFY THE AREAS OF MEASURE IN THOSE INCREMENTS, TO THE EXTENT POSSIBLE. LOOSE BLOCKS ARE ALSO AVAILABLE WHERE THOSE INCREMENTS ARE NOT FEASIBLE.
  3. THE NONWOVEN FILTER FABRIC SHALL BE INCLUDED IN THE COST OF THE ARTICULATED CONCRETE BLOCK REVETMENT SYSTEM (ACBRS) OF THE TYPE SPECIFIED.
  4. THE NONWOVEN FILTER FABRIC SHALL NOT BE INCLUDED IF A DEEP-ROOTED PLANT (SEED MIX 3 AND ABOVE) IS USED IN CONJUNCTION WITH THE ACBRS.
  5. TOPSOIL USED TO BACKFILL THE REVETMENT SYSTEM SHALL BE INCLUDED IN THE COST OF THE ACBRS OF THE TYPE SPECIFIED. SEEDING AND EROSION CONTROL BLANKET TYPE SHALL BE SHOWN ON THE LANDSCAPE PLANS AND WILL BE PAID FOR SEPARATELY.

**NOTE TO DESIGNER**

THIS BASE SHEET SHOWS TYPICAL CONSTRUCTION BUT IT IS NOT A STANDARD DRAWING. IT REQUIRES COMPLETION BY THE DESIGNER PRIOR TO INSERTION INTO A CONTRACT. MICROSTATION FILES AND THE "CADD STANDARDS MANUAL" ARE AVAILABLE ON THE ILLINOIS TOLLWAY WEBSITE. THE DESIGNER SHALL ACCEPT THE RESPONSIBILITY OF THE DESIGN OF THIS SHEET UPON ITS COMPLETION AND INSERTION INTO A CONTRACT. ALL "NOTE TO DESIGNER" BOXES SHALL BE REMOVED BY THE DESIGNER PRIOR TO INSERTION OF THE SHEET INTO THE PLAN SET.



**ARTICULATED CONCRETE BLOCK REVETMENT SYSTEM**

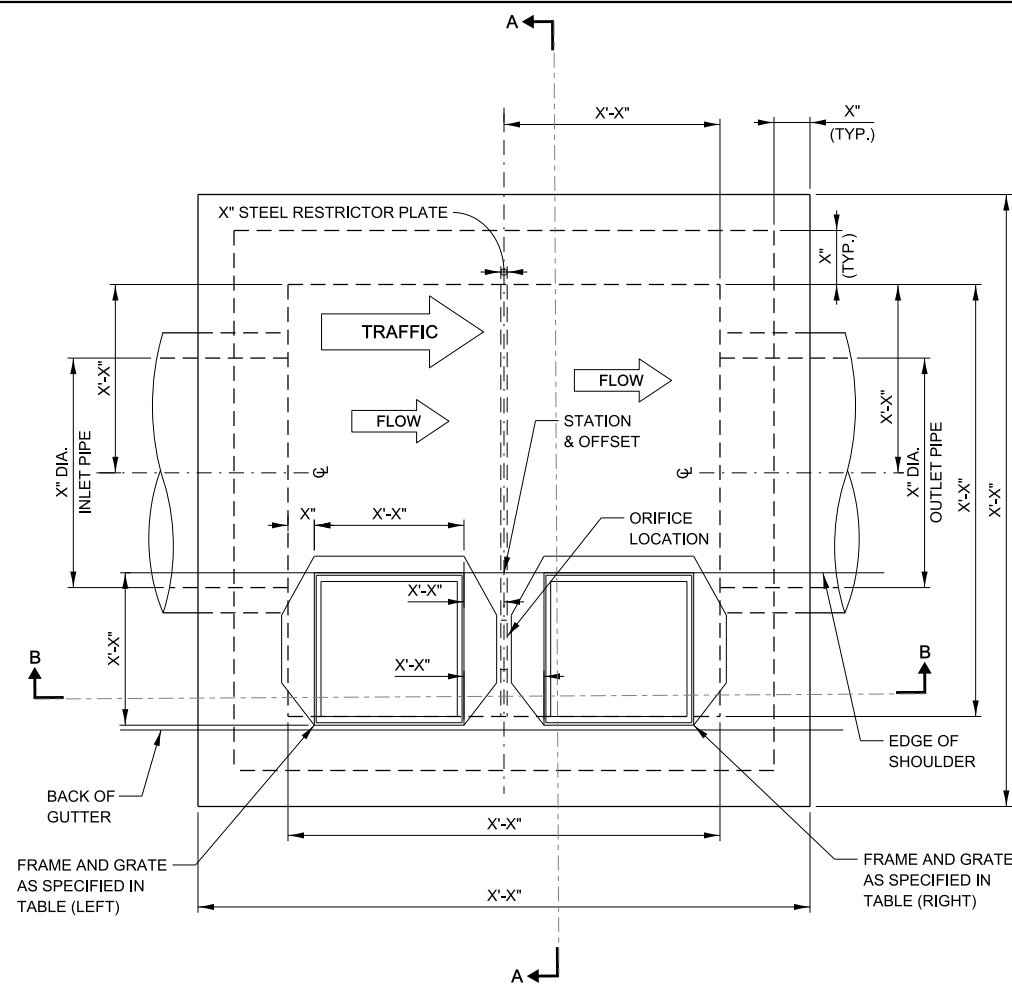

TOP VIEW

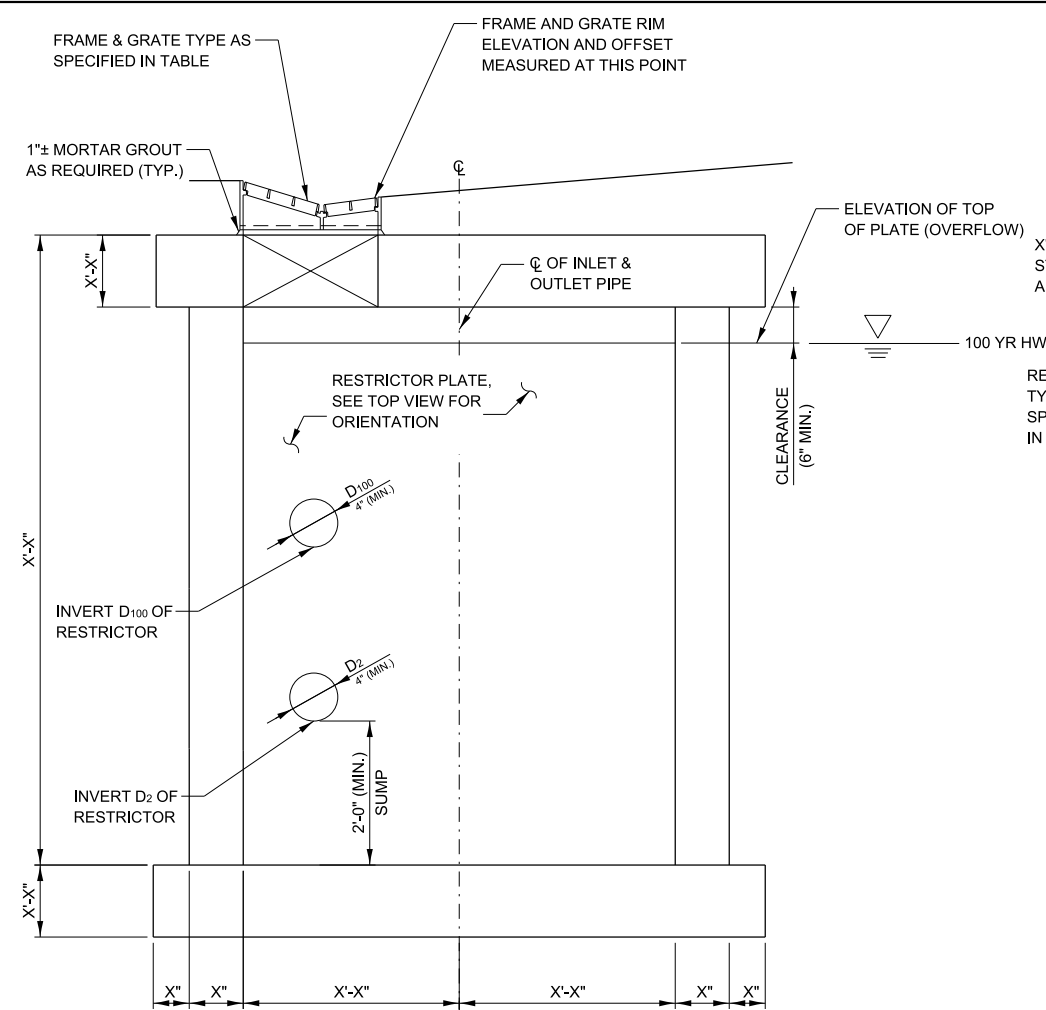

SECTION A-A

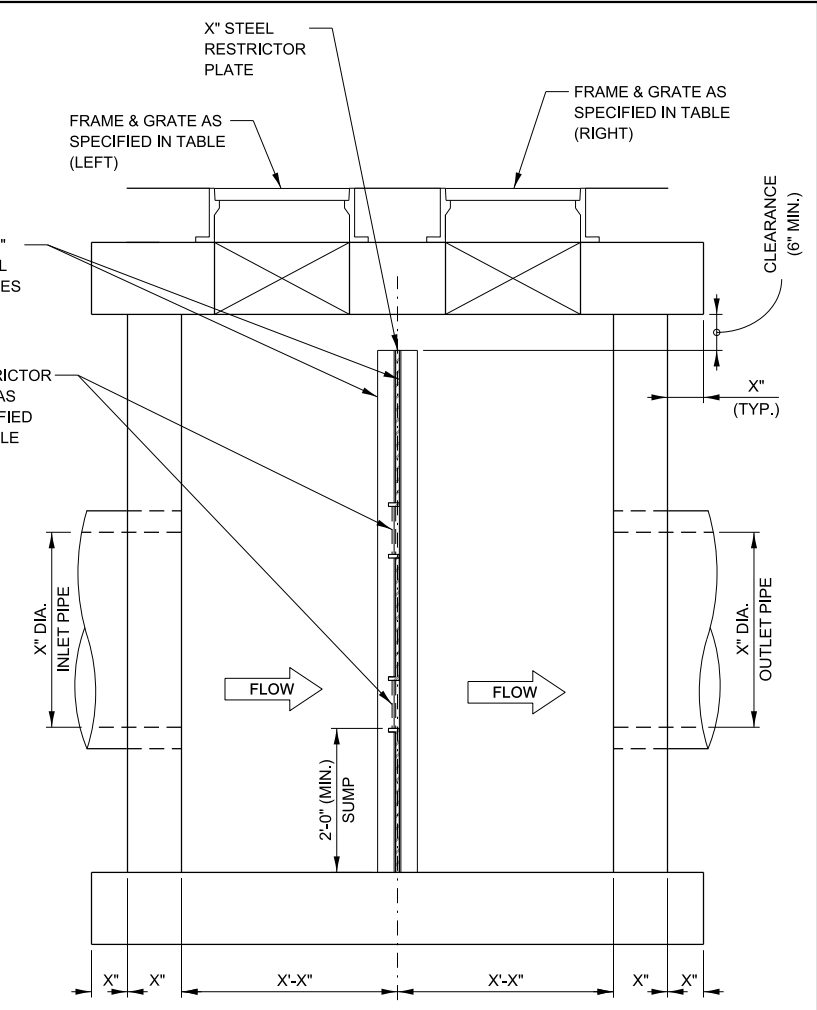

SECTION B-B

RESTRICTOR TYPE					
1	2	3	4	5	6
RE - ENTRANT TUBE	SHARP EDGES	SQUARE EDGED	RE - ENTRANT TUBE	SQUARE EDGED	ROUNDED
LENGTH 1/2 TO 1 DIA.		STREAM CLEARS SIDES	LENGTH: 2-1/2 DIA.	LENGTH: 2-1/2 DIA.	
C=.52	C=.61	C=.61	C=.73	C=.82	C=.98

RESTRICTOR TYPES  
VALUES OF "C" FOR CIRCULAR  
AND SQUARE ORIFICES

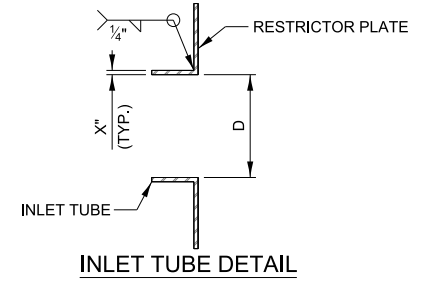

INLET TUBE DETAIL

- NOTES TO DESIGNER**
- DSE SHALL DESIGN STEEL ANGLE BOLTS AND FASTENERS FOR THE RESTRICTOR PLATES. DETAILS ARE TO BE PROVIDED ON THIS SHEET.
  - DSE SHALL PROVIDE REINFORCEMENT DETAILS. DESIGN SHALL BE IN ACCORDANCE WITH AASHTO LRFD BRIDGE DESIGN SPECIFICATIONS, LATEST EDITION, WITH IL-120 OR HL-93 LOADING REQUIREMENTS, WHICHEVER GOVERNS (REFER TO STRUCTURE DESIGN MANUAL).
  - ALL DIMENSIONS DESIGNATED "X" ARE REQUIRED AND SHALL BE UPDATED BY THE DSE.
- NOTE TO DESIGNER**
- THIS BASE SHEET SHOWS TYPICAL CONSTRUCTION BUT IT IS NOT A STANDARD DRAWING. IT REQUIRES COMPLETION BY THE DESIGNER PRIOR TO INSERTION INTO A CONTRACT. MICROSTATION FILES AND THE "CADD STANDARDS MANUAL" ARE AVAILABLE ON THE ILLINOIS TOLLWAY WEBSITE. THE DESIGNER SHALL ACCEPT THE RESPONSIBILITY OF THE DESIGN OF THIS SHEET UPON ITS COMPLETION AND INSERTION INTO A CONTRACT. ALL "NOTE TO DESIGNER" BOXES SHALL BE REMOVED BY THE DESIGNER PRIOR TO INSERTION OF THE SHEET INTO THE PLAN SET.

STRUCTURE NUMBER	* STATION	* OFFSET (FT.)	OFFSET LT/RT	STRUCTURE TYPE	FRAME AND GRATE TYPE	F&G RIM ELEV		INV D <sub>100</sub>	D <sub>100</sub> (IN.)	INV D <sub>2</sub>	D <sub>2</sub> (IN.)	INLET PIPE DIAMETER (IN.)	OUTLET PIPE DIAMETER (IN.)	TOP OF RESTRICTOR PLATE ELEV	RESTRICTOR TYPE	CLEARANCE (FT.)	2 YEAR WATER SURFACE ELEVATION	100 YEAR WATER SURFACE ELEVATION
						LT	RT											

\* SEE TOP VIEW FOR STRUCTURE STATION AND OFFSET



**CATCH BASIN TYPE G (SPECIAL) WITH RESTRICTOR**

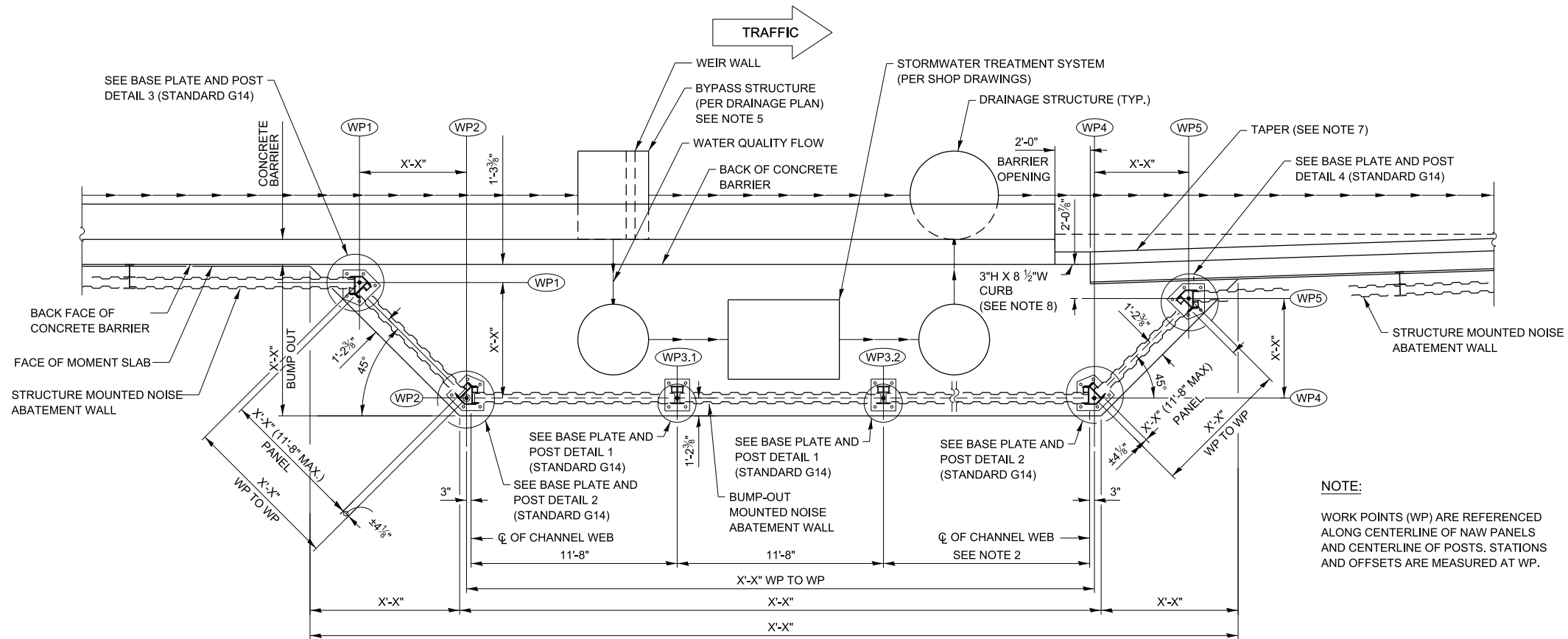

PLAN - STRUCTURE MOUNTED NOISE ABATEMENT WALL EXAMPLE

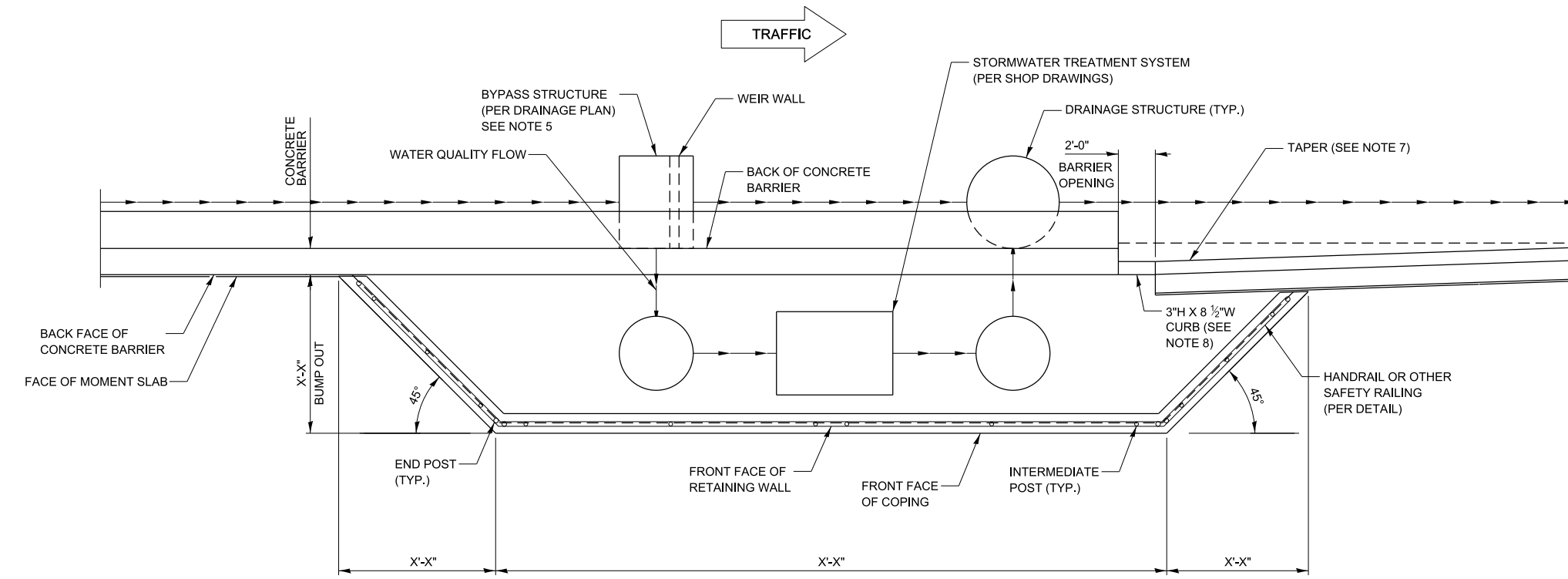

PLAN - RETAINING WALL EXAMPLE

**NOTE TO DESIGNER**

THIS BASE SHEET SHOWS TYPICAL CONSTRUCTION BUT IT IS NOT A STANDARD DRAWING. IT REQUIRES COMPLETION BY THE DESIGNER PRIOR TO INSERTION INTO A CONTRACT. MICROSTATION FILES AND THE "CADD STANDARDS MANUAL" ARE AVAILABLE ON THE ILLINOIS TOLLWAY WEBSITE. THE DESIGNER SHALL ACCEPT THE RESPONSIBILITY OF THE DESIGN OF THIS SHEET UPON ITS COMPLETION AND INSERTION INTO A CONTRACT. ALL "NOTE TO DESIGNER" BOXES SHALL BE REMOVED BY THE DESIGNER PRIOR TO INSERTION OF THE SHEET INTO THE PLAN SET.

- NOTES TO DESIGNER**
- THIS BASE SHEET REPRESENTS THE TYPICAL DETAILS FOR BUMP-OUT RETAINING WALLS OR MOUNTED, NOISE ABATEMENT WALLS. THE DSE IS RESPONSIBLE FOR COMPLETING THE TABLES AND INCLUDING THEM IN THEIR CONTRACT PLANS. IF ANY OF THE DESIGN PARAMETERS IN THE ILLINOIS TOLLWAY STANDARD ARE EXCEEDED, THE DSE WILL BE RESPONSIBLE FOR DESIGN CALCULATIONS AND DETAILS FOR THOSE COMPONENTS. THE GP&E SHEET AND REMAINING NAW PLANS SHALL BE IN ACCORDANCE WITH ILLINOIS TOLLWAY STRUCTURE DESIGN MANUAL ARTICLES 6.2.5 AND 23.3.
  - USE SPECIALTY PANEL AND POST SPACING AT END OF WALL TO ACCOMMODATE TYPICAL 11'-8" POST SPACING ALONG THE STRAIGHT LENGTH OF WALL. POST SPACING SHOULD NOT EXCEED LIMITS WITHIN THE ILLINOIS TOLLWAY STANDARD. IF LIMITS ARE EXCEEDED, DSE TO DESIGN AND DETAIL ALL COMPONENTS. THE "SPX" DESIGNATION FOR SPECIALTY PANELS SHOULD BE USED FOR ALL PANELS WITHIN BAY WITH THE SAME WIDTH.
  - BUMP-OUT MOUNTED NAW DETAILS MAY BE USED WITH SYSTEMWIDE STRUCTURE MOUNTED NAW DETAILS SHOWN IN STANDARD G12 AND M-BRG-529. DSE TO UPDATE ACCORDINGLY FOR SYSTEMWIDE GEOMETRY.
  - THIS SHEET IS NOT TO SCALE. DESIGNER TO DETERMINE APPROPRIATE SCALE ON GENERAL PLAN AND ELEVATION SHEET TO ACCURATELY REPRESENT REQUIRED INFORMATION.
  - A BYPASS STRUCTURE IS REQUIRED IF THE PEAK FLOW EXCEEDS THE CAPACITY OF THE STORMWATER TREATMENT SYSTEM'S INTERNAL OVERFLOW WEIR OR TO REDUCE THE SIZE OF THE STORMWATER TREATMENT SYSTEM.
  - ALL DIMENSIONS DESIGNATED "X" ARE REQUIRED AND SHALL BE UPDATED BY THE DSE.
  - TAPER RATE FOR MAINLINE INSTALLATIONS SHALL BE 30:1. TAPER RATE FOR RAMP AND C-D ROADWAYS SHALL NOT EXCEED THE RATES SHOWN IN AASHTO RDG TABLE 5-9.
  - THE CURB SHALL BE PAID FOR AS CONCRETE SUPERSTRUCTURE.

**NOTE:**

WORK POINTS (WP) ARE REFERENCED ALONG CENTERLINE OF NAW PANELS AND CENTERLINE OF POSTS. STATIONS AND OFFSETS ARE MEASURED AT WP.

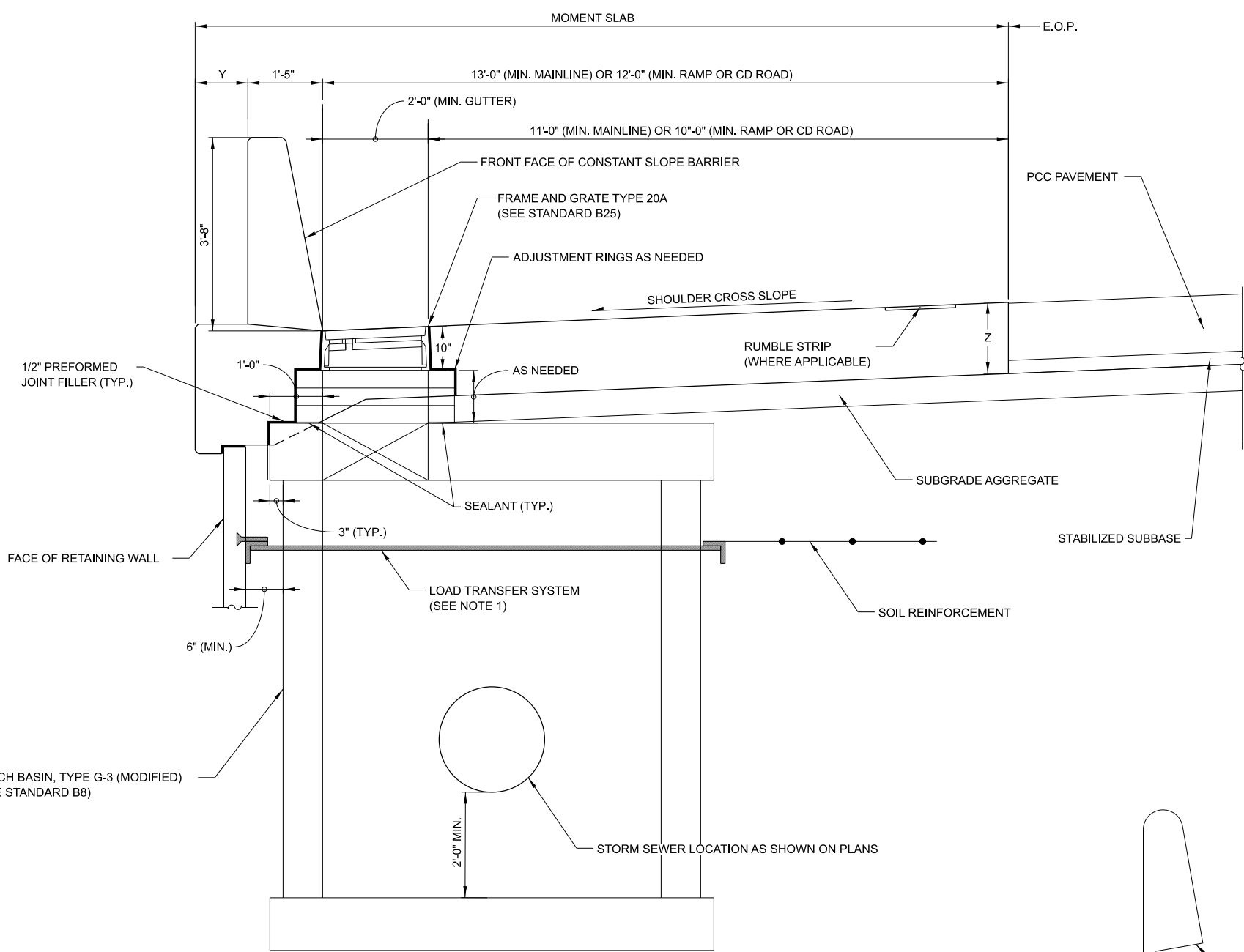

**SECTION A-A THROUGH MOMENT SLAB WITH CATCH BASIN**  
REINFORCEMENT NOT SHOWN FOR CLARITY

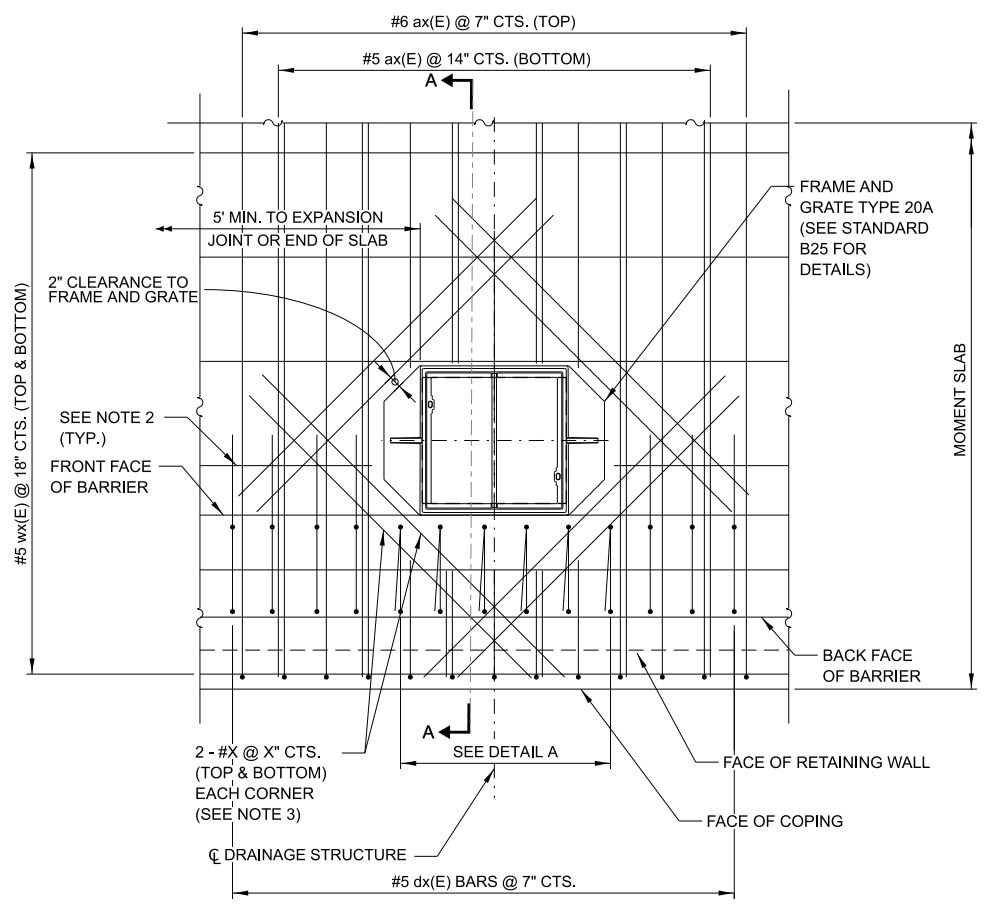

**PLAN - DRAINAGE STRUCTURE**  
TOP REINFORCING IN BARRIER NOT SHOWN FOR CLARITY

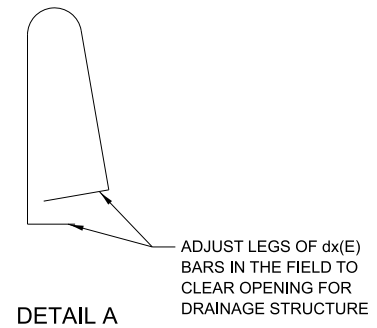

**NOTES:**

- MSE WALL SUPPLIER TO DESIGN LOAD TRANSFER SYSTEM TO ACCOMMODATE DRAINAGE STRUCTURE.
- FIELD CUT MOMENT SLAB REINFORCEMENT ONLY AS REQUIRED FOR DRAINAGE STRUCTURE.
- PLACE BARS SYMMETRICALLY ABOUT CENTERLINE OF DRAINAGE STRUCTURE AS SPACE PERMITS.

**NOTE TO DESIGNER**  
THIS BASE SHEET SHOWS TYPICAL CONSTRUCTION BUT IT IS **NOT** A STANDARD DRAWING. IT REQUIRES COMPLETION BY THE DESIGNER PRIOR TO INSERTION INTO A CONTRACT. MICROSTATION FILES AND THE "CADD STANDARDS MANUAL" ARE AVAILABLE ON THE ILLINOIS TOLLWAY WEBSITE. THE DESIGNER SHALL ACCEPT THE RESPONSIBILITY OF THE DESIGN OF THIS SHEET UPON ITS COMPLETION AND INSERTION INTO A CONTRACT. ALL "NOTE TO DESIGNER" BOXES SHALL BE REMOVED BY THE DESIGNER PRIOR TO INSERTION OF THE SHEET INTO THE PLAN SET.

- NOTES TO DESIGNER**
- THE PURPOSE OF THIS BASE SHEET IS TO SHOW THE PLACEMENT OF THE DRAINAGE STRUCTURE. DSE SHALL REFER TO THE STRUCTURE DESIGN MANUAL FOR THE DESIGN OF ALL STRUCTURAL ELEMENTS.
  - ALL VALUES DESIGNATED "X" ARE REQUIRED AND SHALL BE PROVIDED BY THE DSE.
  - USE 1'-0" MAXIMUM FOR DIMENSION Y TO ENSURE DRAINAGE STRUCTURE CAN BE LOCATED AT THE FRONT FACE OF BARRIER WALL.
  - USE 1'-4" MINIMUM FOR DIMENSION Z. THICKNESS MAY BE MODIFIED TO ACCOMMODATE ADJACENT PAVEMENT.
  - THIS BASE SHEET ILLUSTRATES TYPICAL DETAILS FOR A 44" BARRIER AND MOMENT SLAB WITH CATCH BASIN TYPE G-3 (MODIFIED) WITH FRAME AND GRATE TYPE 20A. DESIGNER SHALL MODIFY DETAILS FOR OTHER TYPES OF MOMENT SLABS, BARRIER HEIGHT AND / OR DRAINAGE STRUCTURES.
  - DESIGNER SHALL REPLACE BAR MARK CALLOUTS DESIGNATED a(E) THROUGH w(E) WITH ACTUAL BAR MARKS.



**EXPOSED MOMENT SLAB WITH DRAINAGE STRUCTURE**

VERSION: 2024-03      STANDARD: M-DRN-606      SHEET: 1 OF 1



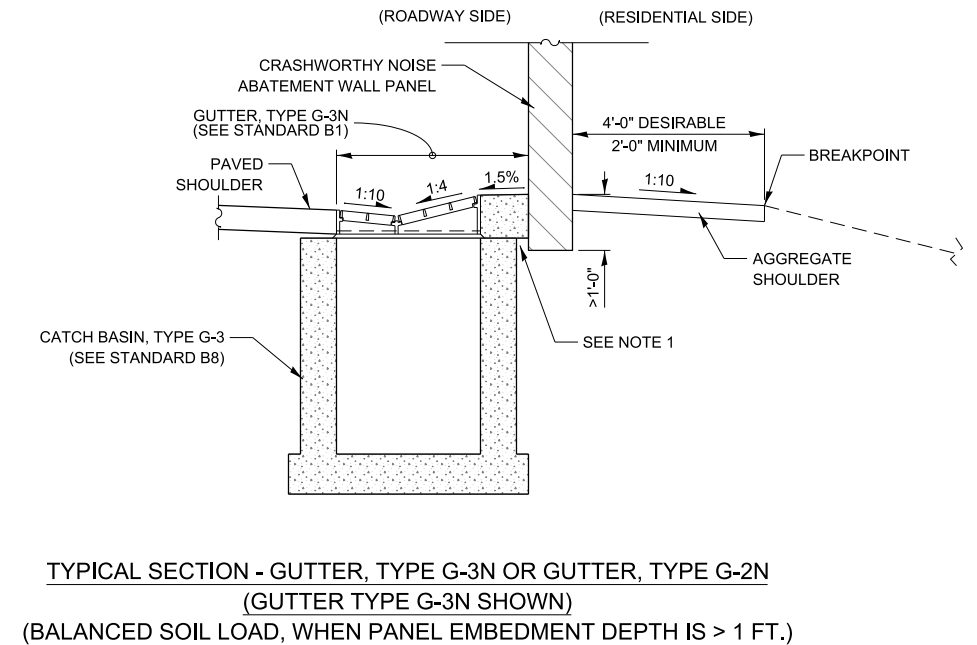
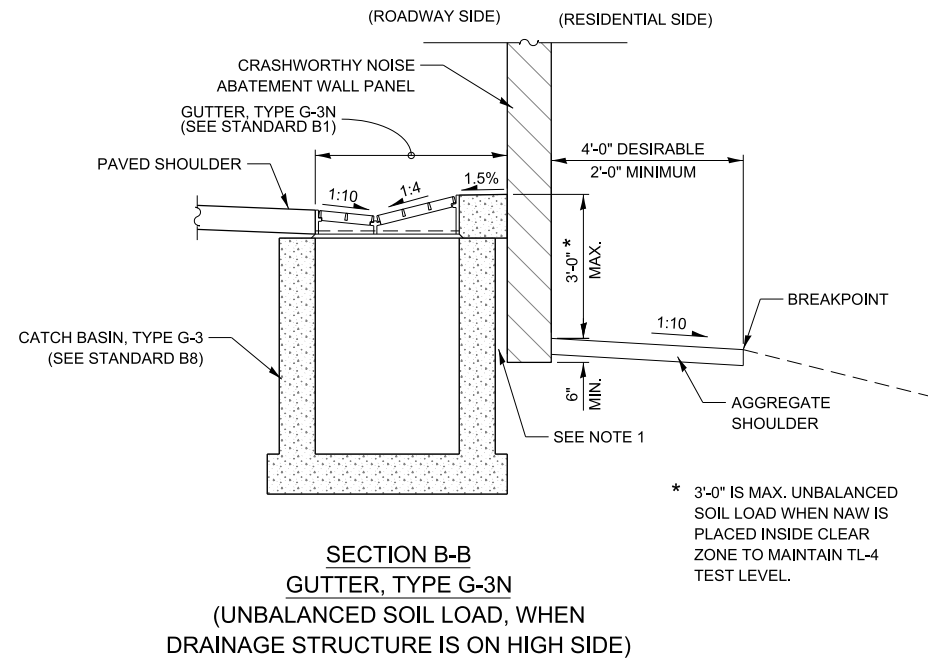
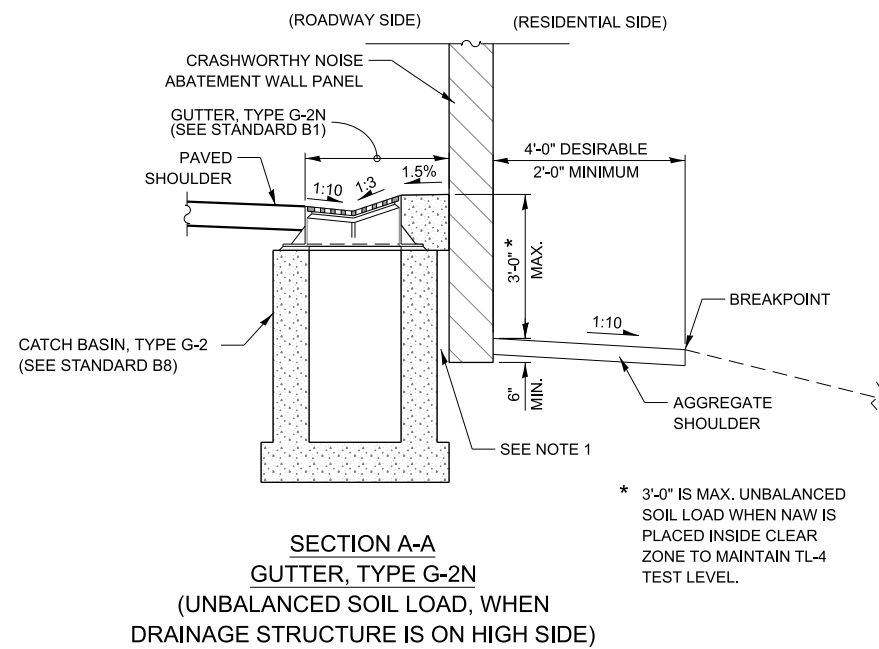
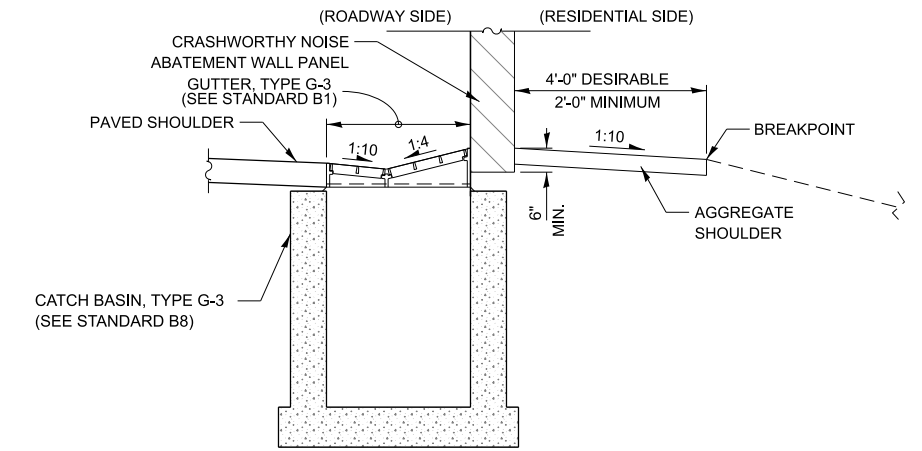
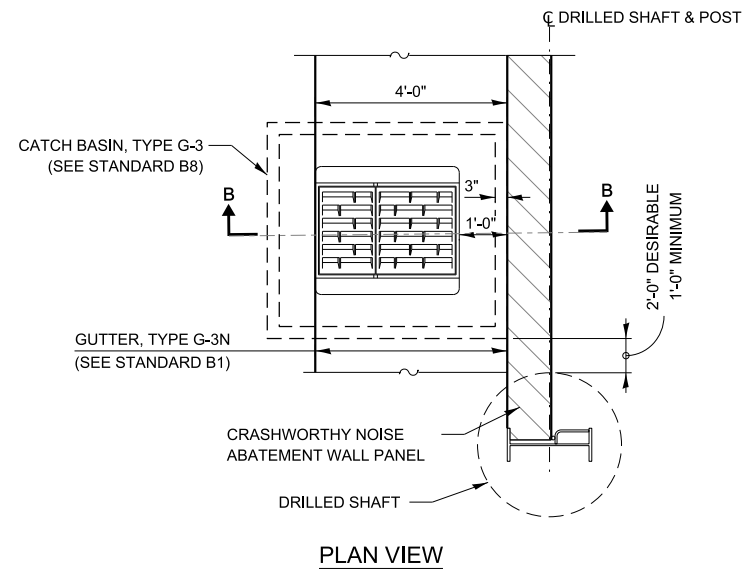
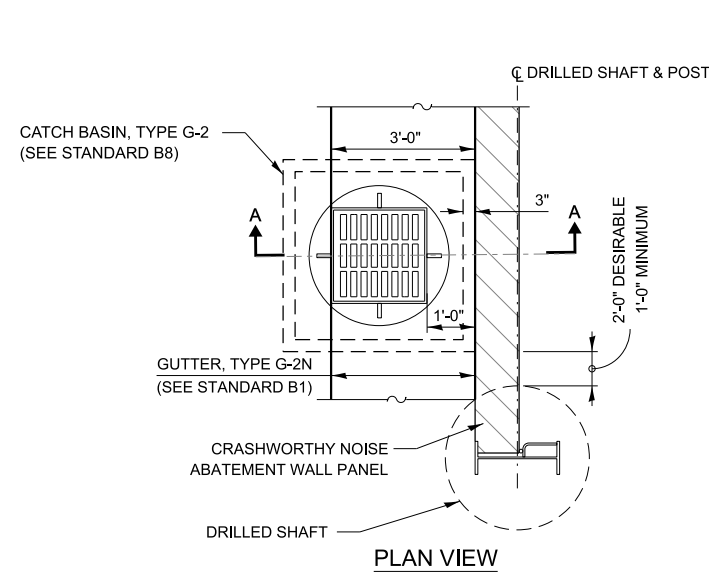

NOTE TO DESIGNER

THIS BASE SHEET SHOWS TYPICAL CONSTRUCTION BUT IT IS NOT A STANDARD DRAWING. IT REQUIRES COMPLETION BY THE DESIGNER PRIOR TO INSERTION INTO A CONTRACT. MICROSTATION FILES AND THE "CADD STANDARDS MANUAL" ARE AVAILABLE ON THE ILLINOIS TOLLWAY WEBSITE. THE DESIGNER SHALL ACCEPT THE RESPONSIBILITY OF THE DESIGN OF THIS SHEET UPON ITS COMPLETION AND INSERTION INTO A CONTRACT. ALL "NOTE TO DESIGNER" BOXES SHALL BE REMOVED BY THE DESIGNER PRIOR TO INSERTION OF THE SHEET INTO THE PLAN SET.

NOTES TO DESIGNER

- FOR NOISE ABATEMENT WALL DETAILS, REFER TO ILLINOIS TOLLWAY STANDARD DRAWINGS G15 AND G16.
- FOR THE SELECTION OF GUTTER TYPE, REFER TO ROADWAY DESIGN CRITERIA MANUAL, ARTICLE 2.6.6.



NOISE ABATEMENT WALL DRAINAGE DETAILS (ROADWAY SIDE)

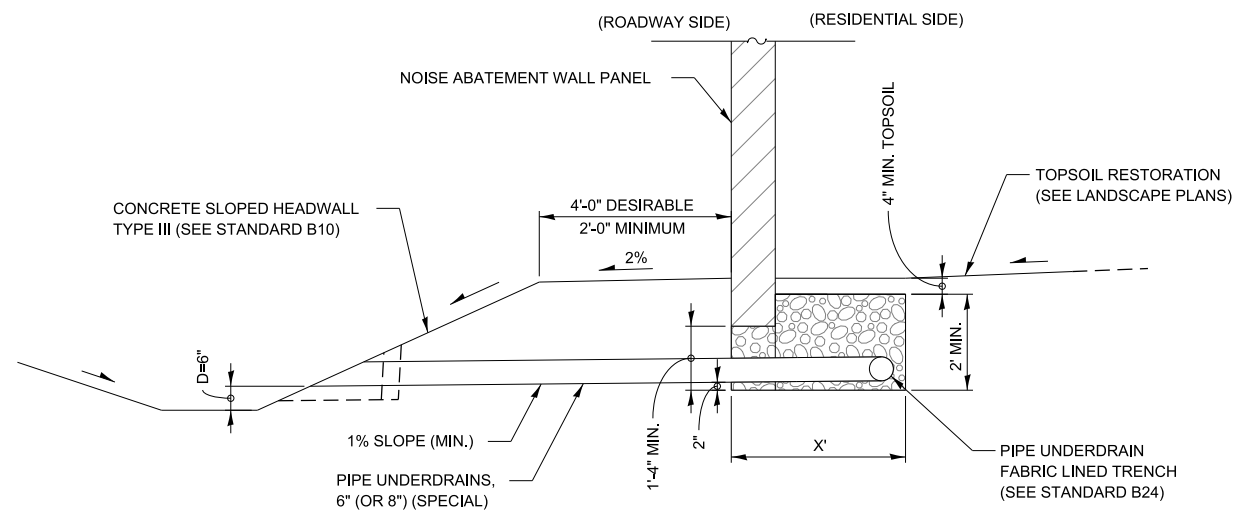

TYPICAL SECTION - PIPE UNDERDRAIN

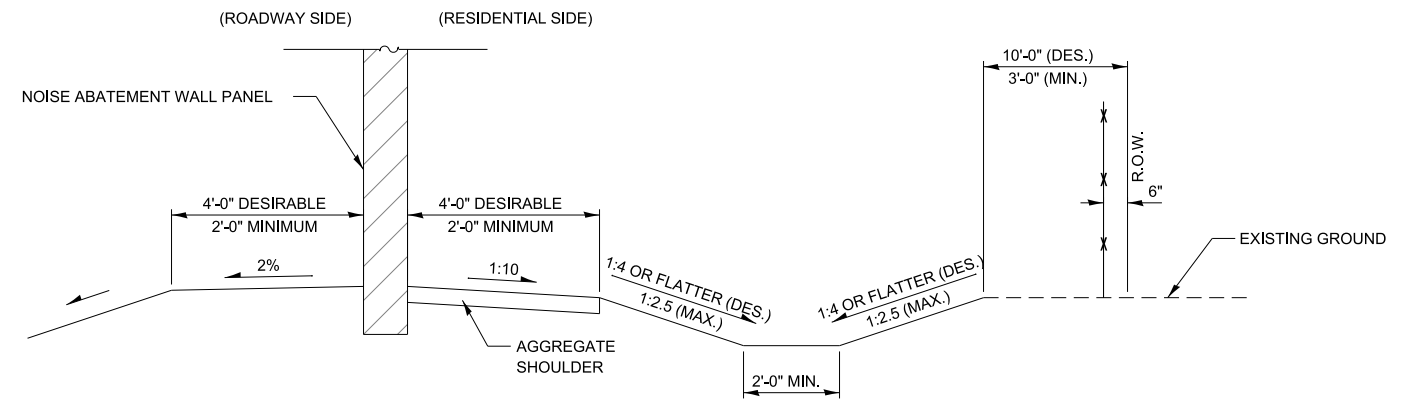

TYPICAL SECTION - DITCH AT THE TOP OF BACKSLOPE

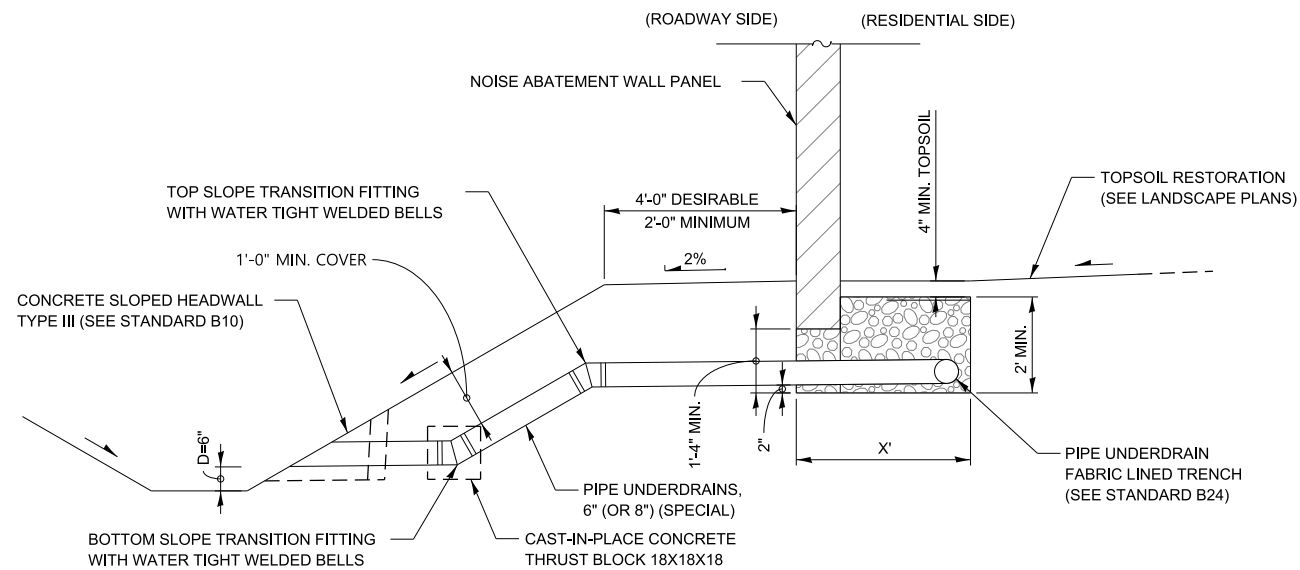

TYPICAL SECTION - PIPE UNDERDRAIN ON HIGH FILL SLOPE

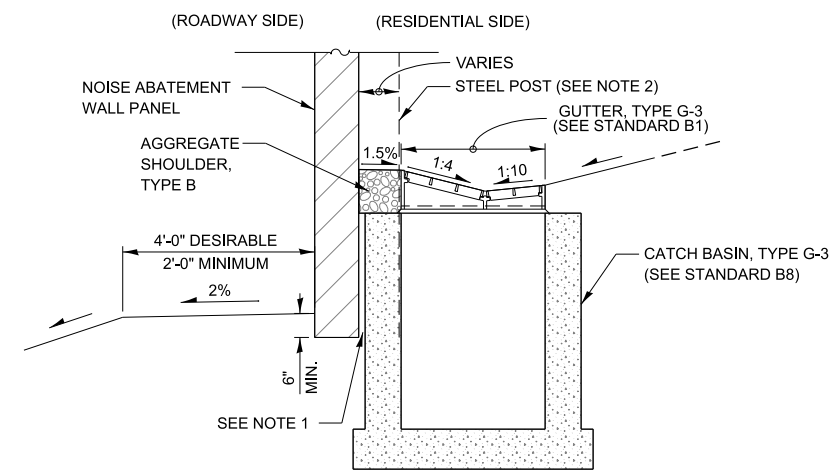

TYPICAL SECTION - GUTTER, TYPE G-3 OR GUTTER, TYPE G-2 (GUTTER, TYPE G-3 SHOWN)  
(UNBALANCED SOIL LOAD, WHEN DRAINAGE STRUCTURE IS ON HIGH SIDE)

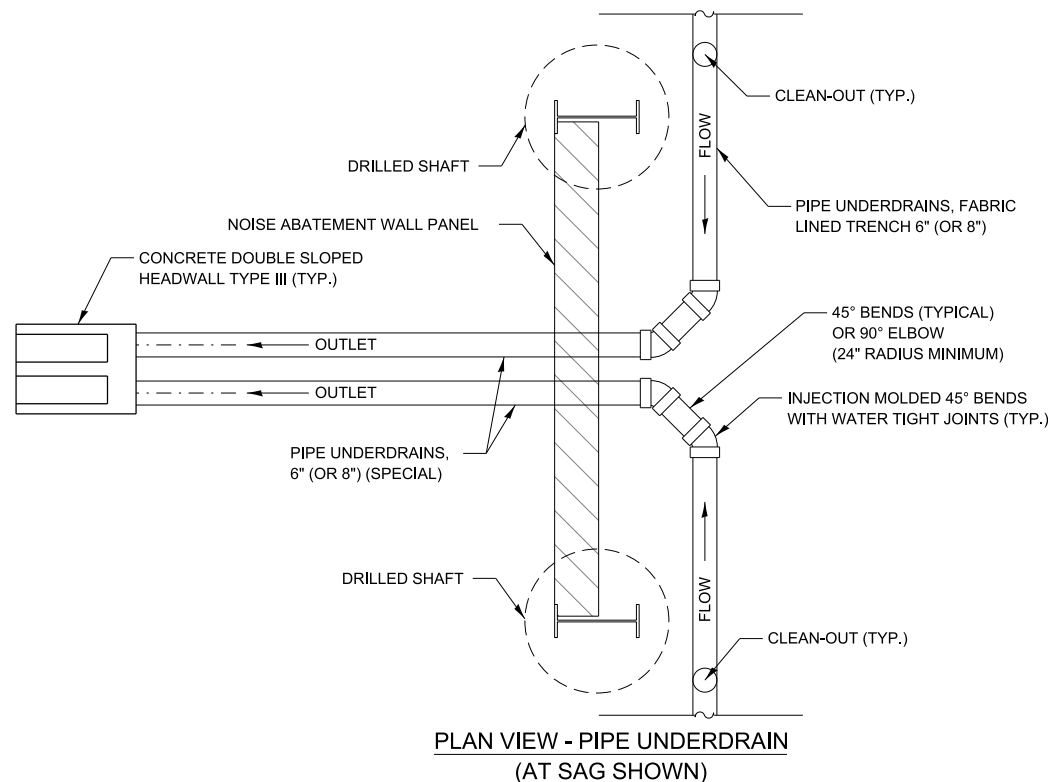

PLAN VIEW - PIPE UNDERDRAIN (AT SAG SHOWN)

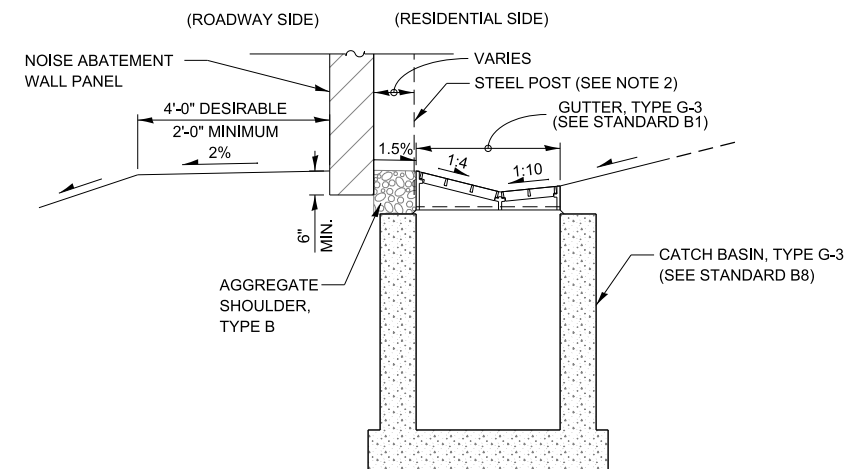

TYPICAL SECTION - GUTTER, TYPE G-3 OR GUTTER, TYPE G-2 (GUTTER, TYPE G-3 SHOWN)  
(BALANCED SOIL LOAD, WHEN PANEL EMBEDMENT DEPTH IS ≤ 1 FT)

**NOTE TO DESIGNER**

THIS BASE SHEET SHOWS TYPICAL CONSTRUCTION BUT IT IS NOT A STANDARD DRAWING. IT REQUIRES COMPLETION BY THE DESIGNER PRIOR TO INSERTION INTO A CONTRACT. MICROSTATION FILES AND THE "CADD STANDARDS MANUAL" ARE AVAILABLE ON THE ILLINOIS TOLLWAY WEBSITE. THE DESIGNER SHALL ACCEPT THE RESPONSIBILITY OF THE DESIGN OF THIS SHEET UPON ITS COMPLETION AND INSERTION INTO A CONTRACT. ALL "NOTE TO DESIGNER" BOXES SHALL BE REMOVED BY THE DESIGNER PRIOR TO INSERTION OF THE SHEET INTO THE PLAN SET.

**NOTES TO DESIGNER**

- THE DETAILS SHOWN ARE ACCEPTABLE OPTIONS TO DRAIN THE AREA ADJACENT TO A NOISE ABATEMENT WALL (RESIDENTIAL SIDE). THE MOST FEASIBLE OPTION IS SITE SPECIFIC. IF GUTTER IS USED, REFER TO ROADWAY DESIGN CRITERIA MANUAL, ARTICLE 2.6.6 FOR THE SELECTION OF GUTTER TYPE. THE DESIGNER IS RESPONSIBLE FOR PROVIDING SUPPORTING DRAINAGE CALCULATIONS TO DETERMINE THE MOST FEASIBLE OPTION. THE DESIGNER IS ALSO RESPONSIBLE FOR DESIGNING AND DETAILING ALL DITCHES, DRAINAGE STRUCTURES AND STORM SEWERS ON THE DRAINAGE PLAN AND PROFILES.
- DETERMINE DIMENSION X TO OFFSET PIPE UNDERDRAIN TO AVOID CONFLICT WITH THE DRILLED SHAFTS.
- PIPE UNDERDRAINS SHALL MEET THE REQUIREMENTS OF DDM ARTICLE 9.7.2, DDM TABLE 9.3 AND STANDARD B24.
- FOR NOISE ABATEMENT WALL DETAILS, REFER TO ILLINOIS TOLLWAY STANDARD DRAWINGS G15 AND G16.

**NOTES:**

- FILL GAP WITH CLSM, GROUT OR CLASS SI CONCRETE IN ACCORDANCE WITH THE STANDARD SPECIFICATIONS.
- PROVIDE JOINT FILLER BETWEEN THE STEEL POST AND GUTTER.



**NOISE ABATEMENT WALL DRAINAGE DETAILS (RESIDENTIAL SIDE)**