

S.P. 111.2 STORM WATER POLLUTION PREVENTION PLAN

1. Site Description.

The following is a description of the construction activity which is the subject of this plan:

a. Project Location

The work under this contract shall be performed at various locations at Elgin O'Hare Western Access along Franklin Avenue in the Village of Bensenville, Cook County, Illinois.

b. Description of the Construction Activity

The work under this contract includes, demolition of 1 commercial /industrial property including but not limited to:

- 1) Commercial and Industrial building board up services
- 2) Site clearing and grading
- 3) Erosion and sediment control
- 4) Environmental testing for asbestos
- 5) Asbestos, lead, or other regulated substances removal and remediation (as necessary)
- 6) Building demolition
- 7) Pavement removal
- 8) Topsoil and seeding
- 9) Mowing
- 10) Temporary /permanent fencing
- 11) Trees and tree stump removal
- 12) Maintenance of traffic during construction
- 13) Utility disconnection and removal
- 14) Other ancillary removals as required

c. Sequence of Major Earth Disturbing Construction Activities

The following is a description of the intended sequence of major activities which will disturb soils for major portions of the construction site, such as clearing, excavation, grading and on-site or off-site stockpiling of soils or storage of materials:

1. Building board up and temporary fencing
2. Installation of temporary erosion control measures as required
3. Site clearing, tree removal, pavement removal, utility disconnection and removal
4. Building demolition and waste removal
5. Backfilling of excavations and voids as a result of removal operations.
6. Remove temporary erosion and sediment control measures and restore disturbed areas.
7. Removal and disposal of waste or hazardous waste materials, related to temporary erosion controls, shall be per the Tollway Supplemental Specifications.
8. Topsoil placement and permanent seeding of disturbed areas

The aforementioned general description of construction staging will be modified by the Contractor's Progress Schedule that will be part of the SWPPP. The Contractor shall revise the Suggested Progress Schedule which will be maintained and updated as necessary and made part of the SWPPP.

d. Total Construction Area and Total Area of Earth Disturbance

The total area of the construction sites is estimated to be 11.693 acres (including on-site or off-site stockpiling of soils or storage of materials).

The total project area of the site that it is estimated to be disturbed by excavation, grading, or other earth disturbing activities is 2.0 acres.

e. Runoff Coefficients

The following estimates are provided for the construction site:

Percentage impervious area before construction: 13%
Runoff coefficient before construction: .25
Percentage impervious area after construction: 12%
Runoff coefficient after construction: .24

f. Soil Characteristics

The soil type within the project limits are 533 (Urban Land) and 805B (Orthents, loamy, undulating) with 1 to 6% slopes, as identified by the Natural Resources Conservation Service (NCRS) Web Soil Survey.

Over 90% of construction site surface consists of impervious area and well-graded gravel mixtures that contains little to no erodible soils. The existing well-grade gravel exhibits high permeability and infiltration capacity to help prevent or delay runoff. Areas of that do not have well-grade gravel are not anticipated to be disturbed and are covered with vegetation and therefore these areas have a low susceptibility to erosion.

The soil type 805B described above in the NCRS Web Soil Survey is not anticipated to be encounter with building demolition work.

g. Topography and Drainage

A description of the existing drainage patterns and topographic features relative to their impact on erosion and sediment control is summarized below:

- Most of the project area (approximately 90%) is stabilized with impervious surface and gravel. The remaining portion of the project area includes grass, trees and shrubs.

- The topography across the project is generally flat with slopes between 0-2%. There are no steep or lengthy slopes within the project limits that represent areas of increased erosion potential.
- The current stormwater runoff flows to onsite drainage structures which eventually will be discharged into Addison Creek.

h. Drainage System Ownership

The drainage systems which receive stormwater discharge from the project are owned by Village of Franklin Park, Village of Bensenville, and the Illinois Tollway.

i. Receiving Waters and Wetland Acreage

There are no acres of wetland within the project limits.

j. 303(d) Listed Receiving Waters

The direct receiving water for the project is the Addison Creek (GLA-04) and is not identified by the IDNR as a "biologically significant stream".

The Addison Creek (GLA-04) is listed on the 303(d) list as impaired for the following:

- Aesthetic Quality: Bottom Deposits
- Aesthetic Quality: Phosphorus (Total)
- Aesthetic Quality: Visible Oil
- Aquatic Life: alpha.-BHC
- Aquatic Life: Copper
- Aquatic Life: Hexachlorobenzene
- Aquatic Life: Phosphorus (Total)
- Aquatic Life: Polychlorinated biphenyls
- Aquatic Life: Sedimentation/Siltation

The compounds listed above are not designated for specific uses on the project, however good housekeeping procedures shall be implemented by all contractors and the following erosion control measures will minimize the potential for soils to enter sensitive areas or Addison Creek.

The Erosion and Sediment Control Concept consists of the following:

- Erosion Control Blanket will be used in all seeding areas.
- Silt fence will be used at the perimeter of construction area
- Temporary Erosion Control Seeding will be used to stabilize bare earth during temporary halts in construction.
- Permanent seeding will be used as permanent erosion control measures.

k. Receiving Waters with Total Maximum Daily Load (TMDL)

There is no IEPA-established or approved TMDL published for the receiving water(s) listed in Section 1.j.

l. Site Features and Sensitive Areas to be Protected

Sensitive environmental resources or site features on or adjacent to the project site that will have the potential to be impacted by the proposed construction and are to be protected and/or remain undisturbed are identified below. These may include but are not limited to steep slopes, highly erodible soils, wetlands, streams and other waterways, existing natural buffers, specimen trees, natural and mature vegetation, nature preserves, floodplains, bioswales, threatened or endangered species, and historic/archaeological resources.

There are no sensitive environmental resources or site features on or adjacent to the project site that have the potential to be impacted by the proposed construction and are to be protected and/or remain undisturbed

m. Pollutants and Pollutant Sources

The following pollutants and pollutant sources are anticipated to be associated with the project:

- Soils and Sediment
- Demolition Waste
- Paving Operation Materials and Waste
- Cleaning Products
- Joint and Patching Compounds
- Concrete Curing Compounds
- Painting Products and Wastes
- Sandblasting Materials and Waste Products
- Landscaping Materials and Wastes
- Soil Amendments and Stabilization Products

- Building Construction Materials and Wastes
- Vehicle and Equipment Fluids
- Building Construction Materials and Wastes
- Portable Toilet Wastes
- Litter and Miscellaneous Solid Waste
- Glues, Adhesives, and Sealants
- Contaminated Soils
- Dust Palliative Products
- Other (specify):
- Other (specify):
- Other (specify):
- Other (specify):

n. Applicable Federal, State or Local Requirements

Procedures and requirements specified in applicable sediment and erosion control site plans or storm water management plans approved by local officials, or are required by Federal or State regulatory agencies are described below:

- The management practices, controls, and other provisions provided in the SWPPP are at least as protective as the requirements contained in the Illinois Urban Manual.
- The State of Illinois procedures and standards for urban soil erosion and sediment that are applicable to protecting surface waters, upon submittal of the Notice of Intent to authorize discharges under the ILR10 permit, are incorporated by reference and are enforceable under the permit even if they are not specifically included in the plan. Any additional BMPs which are required beyond those specified herein and/or shown on the Erosion and Sediment Control Plans shall also meet the requirements of the Illinois Urban Manual.
- The proposed improvements comply with FAA Advisory Circular (AC) No. 150/5200-338, Hazardous Wildlife Attractants on or near Airports (dated August 28, 2007). Specific requirements pertaining to stormwater management facilities, wetland mitigation, and landscaping were coordinated with and confirmed by the FAA and the U.S. Department of Agriculture - Animal and Plant Health Inspection Service (USDAAPHIS). The principal criteria include no new wildlife attractants (e.g., open water, wetlands, or vegetation attractive to wildlife) within five miles of the airport.
- The project is entirely located within the existing Illinois Tollway ROW. There are no local Municipal Separate Storm Sewer System (MS4) requirements applicable to the contract.

2. Controls.

This section of the plan addresses the various controls that will be implemented for each of the major construction activities described in 1.b. above. For each measure discussed, the contractor that will be responsible for its implementation as indicated. Each such contractor has signed the required certification on forms which are attached to, and are part of, this plan.

a. Stabilization Practices

Stabilization of disturbed areas must, at a minimum, be initiated immediately whenever any clearing, grading, excavation or other earth disturbing activities have permanently ceased on any portion of the site, or temporarily ceased on any portion of the site and will not resume for a period exceeding 14 calendar days. Stabilization of disturbed areas must be initiated within 1 working day of permanent or temporary cessation of earth disturbing activities and shall be completed as soon as possible but not later than 14 days from the initiation of stabilization work in an area. Where the initiation of stabilization measures is precluded by snow cover, stabilization measures shall be initiated as soon as practicable.

Where shown on the Contract Plans, Same-Day Stabilization shall be utilized to reduce the movement of soils once they are exposed by the Contractor's operations. Same-Day Stabilization is to be implemented after the initial perimeter controls are in place and concurrently with the Contractor's daily operations. In this case, the work zone must be left in such condition that the grading areas disturbed that day are stabilized, and measures are in place to control sediment laden stormwater.

The Engineer may also direct the Contractor to provide Same-Day Stabilization to critical disturbed areas where there is a risk that sediment laden runoff may occur. When directed by the Engineer, Same-Day Stabilization of specified areas shall commence the same day as directed and shall be completed no later than 24 hours after receipt of such direction.

Same-Day Stabilization may consist of either temporary erosion control measures or the permanent landscaping indicated on the Contract Plans. When permanent landscaping is not possible, due either to construction staging or site constraints, Same-Day Stabilization shall consist of temporary erosion control measures.

Provided below is a description of interim and permanent stabilization practices, including site-specific scheduling of the implementation of the practices and the locations for use. Site plans should ensure that existing vegetation is preserved where practicable and disturbed portions of the site are stabilized.

The following stabilization practices will be used for this project:

- Temporary Stabilization with Straw Mulch
- Same-Day Stabilization
- Erosion Control Blanket
- Temporary Seeding
- Permanent Seeding
- Tree Protection Fence
- Mulching
- Geotextiles
- Sod
- Vegetative Buffer
- Staged or Staggered Development
- Dust Control Watering
- Dust Suppression Agents
- Soil Stockpile Management
- Other (specify):
- Other (specify):
- Other (specify):
- Other (specify):

Description of Interim Stabilization Practices:

- Dust Control Watering: Implemented using a spray application of water as necessary to control fugitive dust emissions. Repetitive treatment will be applied as needed to accomplish dust control when temporary dust control measures are used. A water truck will be present on site (or available) for sprinkling/irrigation to limit the amount of dust leaving the site. Watering will be applied daily (or more frequently) to be effective. If field observations indicate that additional protection (in addition to, or in place of watering) is necessary, alternative dust suppressant controls will be implemented at the discretion and approval of the Engineer.

Description of Final Stabilization Practices:

- Once Building demolition is completed, erosion blankets and seeding will be applied to all disturbed areas.

The Engineer and Contractor shall maintain records of the dates when major grading activities occur, when construction activities have temporarily or permanently ceased on a portion of the site, and when stabilization measures area initiated.

b. Structural Practices

Provided below is a description of structural practices that will be implemented, to the degree attainable, to divert flows from exposed soils, store flows, or otherwise limit runoff and the discharge of pollutants from exposed areas of the site. Included in the description is the site-specific scheduling of the implementation of the practices and the locations for their use.

The following structural practices will be used for this project:

- Silt Fence
- Super Silt Fence
- Temporary Ditch Checks
- Temporary Rock Check Dams
- Filter Fabric Inlet Protection, Basket Type
- Filter Fabric Inlet Protection, Cover Type
- Rectangular Inlet Protection
- Culvert Inlet Protection Fence
- Culvert Inlet Protection Stone
- Sediment Traps
- Sediment Basins
- Temporary Pipe Slope Drains
- Temporary Stream Crossings
- Stabilized Construction Entrances
- Temporary Riprap
- Temporary Swales
- Temporary Channel Diversion
- Diversion Dike
- Sediment Filter Bag
- Dewatering Basin
- Flotation Boom
- Other (specify):
- Other (specify):
- Other (specify):
- Other (specify):

Description of Structural Practices:

- Silt Fence: Shall be installed at the locations indicated on the Erosion and Sediment Control Plans and other locations where it is deemed necessary to filter sediment from storm runoff. The fence is designed to retain sediment-laden water to allow settlement of suspended soils before filtering through the mesh fabric for discharge downstream. Perimeter silt fence shall be installed prior

to the initiation of earth disturbing construction activities. Silt fence will be installed around temporary topsoil stockpiles and will be installed prior to beginning stockpiling activities.

- **Stabilized Construction Entrances:** Vehicles and equipment will access the construction site at the designated stabilized construction entrances to control offsite tracking of sediments at locations shown on the plans or as directed by the Engineer. Stabilized construction entrance(s) shall be constructed in conformance with the Illinois Tollway Supplemental Specifications and Standard Design Details. The rough texture of the stone helps to remove clumps of soil adhering to construction vehicle tires through the action of vibration and jarring over the rough surface and the friction of the stone matrix against soils attached to vehicle tires. Any track-out that occurs beyond the stabilized construction entrance shall be removed by wet sweeping no later than the end of the day in which the track-out occurs, or more frequently as directed by the Engineer.
- **Fabric Inlet Protection:** Will be provided at all proposed drainage structures as they are constructed and any existing structures that will be receiving flow within the construction limits. The primary function is to place controls in the path of flow sufficient to slow sediment laden water to allow settlement of suspended soils before discharging into the storm sewer system. Fabric inlet protection will consist of manufactured filter baskets in paved areas and rectangular inlet protections in unpaved areas.

c. Treatment Chemicals

Provided below is a description of the planned use of polymer flocculants or treatment chemicals at the site. The location, use, and application technique, along with an explanation of need for their use is provided.

- The use of polymer flocculants or other chemicals to treat stormwater runoff on the project are not planned or anticipated.

d. Permanent Storm Water Management Controls

No permanent storm water management controls will be installed as part of the project.

e. Pollution Prevention

The following pollution prevention measures will be implemented to minimize the exposure of products or materials to precipitation and stormwater and minimize the discharge of pollutants on the project site:

- **Vehicle/Equipment Storage, Cleaning and Maintenance.** Construction vehicles will be inspected frequently to identify any leaks, which will be repaired immediately, or the vehicle will be removed from site. If minor vehicle/equipment maintenance must occur on site, repairs and maintenance will be made within an approved staging or storage area, or other approved location, to prevent the migration of mechanical fluids to watercourses, wetlands or storm drains. Spill response equipment shall be readily available when performing any vehicle or equipment maintenance. When not in use, vehicles and equipment utilized for construction operations will be staged outside of the regulatory floodplain and away from any natural or created watercourses, ponds, drainage-ways or storm drains. Cleaning of vehicles and equipment is discouraged and will be performed only when necessary to perform repairs or maintenance. Cleaning of vehicles and equipment with soap, solvents or steam shall not occur on the project. Vehicle and equipment wash water shall be contained for percolation or evaporative drying away from storm drain inlets or watercourses.

- **Prohibited Discharges.** The following non-storm water discharges are prohibited: concrete and wastewater from washout of concrete (unless managed by an appropriate control), wastewater from washout and cleanout of stucco, paint, form release oils, curing compounds and other construction materials, fuels, oils, or other pollutants used in vehicle and equipment operation and maintenance, soaps, solvents, or detergents, toxic or hazardous substances from a spill or other release, or any other pollutant that could cause or tend to cause water pollution.

- **Material Delivery and Storage.** The following procedures and practices for the proper handling, delivery, and storage of products and construction materials will be followed to reduce the risk of spills or other accidental exposure of materials and substances to stormwater runoff:
 - Fuel, oils, hydraulic fluids, and other petroleum products shall be stored under cover or in a containment area.
 - Locate chemical and material storage areas away from low elevation areas, drainage areas, and stream banks, and outside the 100-year floodplain. Provide readily available Safety Data Sheets for all materials used or stored on the project site.
 - Ensure access is available to storage areas to allow for spill clean-up and emergency response.
 - Maintain temporary containment facilities in a condition free of accumulated rainwater and spills.

- Store materials in their original containers and maintain the original product labels in place and in a legible condition. Replace damaged or otherwise illegible labels immediately.
 - Keep ample supply of appropriate spill clean-up material near storage areas.
 - Minimize the material inventory stored on-site to the extent practical.
 - All materials stored on site will be stored in a neat, orderly manner in their appropriate containers.
 - Substances will not be mixed with others unless recommended by the manufacturer.
 - The Contractor will inspect storage areas daily to ensure proper use and disposal of materials on-site.
 - Whenever possible, all product will be used before disposing of the container.
 - Manufacturer's recommendations for proper use and disposal will be followed.
 - If surplus product must be disposed of, manufacturer's or local and state recommended methods for proper disposal will be followed.
 - Keep an accurate, up-to-date inventory of material delivered and stored onsite.
 - Have employees trained in emergency spill clean-up procedures present when dangerous materials or liquid chemicals are unloaded.
 - Repair or replace perimeter controls, containment structures, covers, and liners as needed to maintain proper function.
- Spill Response. The following practices will be followed to minimize, control and respond to spilled material:
 - The Contractor shall prepare and implement a Spill Prevention and Control Plan.
 - Manufacturer's recommended methods for spill cleanup will be clearly posted, and site personnel will

be made aware of the procedures and location of the information and cleanup supplies.

- Materials and equipment necessary for spill cleanup will be kept in the material storage area(s) and shall be appropriate for the materials stored.
- All spills will be cleaned up immediately after discovery.
- The Contractor will dispose of used clean-up materials, contaminated materials, and recovered spill material that is no longer suitable for the intended purpose, in accordance with all applicable laws, rules, and regulations.
- Spills of toxic or hazardous material will be reported to the appropriate state or local government agency, regardless of size.
- In the event of any spills, the Spill Prevention and Control Plan will be adjusted to include additional measures to prevent the type of spill from recurring.
- The Contractor shall be responsible for day-to-day operations and will designate a Spill Prevention and Cleanup Coordinator (Coordinator). The Coordinator will designate at least two (2) other site personnel who will receive spill prevention and cleanup training. These individuals will each become responsible for a particular phase of prevention and cleanup. The names of responsible spill personnel, listed below, will be posted in the material storage area and in the office trailer on-site.

Spill Prevention and Cleanup Coordinator:

Ricardo Martinez

Printed Name

Martinez Frogs, Inc.

Contractor Name

Additional Trained Spill Prevention and Response Personnel:

Juan David Lopez

Printed Name

Martinez Frogs, Inc.

Contractor Name

Jose Alcantar

Printed Name

Martinez Frogs, Inc.

Contractor Name

f. Other Controls

Practices to prevent the discharge of pollutants to the storm drain system or to watercourses as a result of the creation, collection, and disposal of wastes are as follows:

- **Solid Wastes.** No solid materials, including building materials, shall be discharged into Waters of the U.S., except as authorized by a Section 404 permit. Solid waste storage areas shall be located at least 50 feet from drainage facilities and watercourses and outside of areas prone to flooding or ponding. Designate waste storage areas and provide dumpsters of sufficient size and number with lids to contain the solid waste generated by the project. In addition, provide trash receptacles in laydown yards, field trailer areas or at locations where workers congregate for lunch and break periods. Non-salvageable solid waste shall be disposed in accordance with all laws, rules, and applicable regulations.
- **Sanitary Waste Materials.** The Contractor shall not create or allow unsanitary conditions. All personnel involved with construction activities must comply with state and local sanitary or septic system regulations. Temporary sanitary facilities will be provided at the site throughout the construction phase. They must be utilized by all construction personnel and serviced by a commercial operator to maintain function and prevent unsanitary conditions. Portable

toilets must be securely anchored and are not allowed within 30 feet of stormwater inlets or within 50 feet of a Water of the U.S.

- **Concrete Wastes:** Concrete washout and slurries generated from saw-cutting, coring, grinding, milling, grooving, or similar construction activities are required to be contained and are prohibited from entering storm drains or watercourses. Concrete waste management and disposal shall conform to Article 280.28 of the Illinois Tollway Supplemental Specifications.
- **Concrete Dust Particles:** Dust particles and other fine materials generated due to the use of rubblized or recycled concrete as roadway base, must be removed from stormwater prior to the water discharging outside of Illinois Tollway ROW. This material can be removed via vegetated ditches if there is enough time and space for removal prior to the discharge of the stormwater outside the ROW. For those areas where there is not enough space and time for vegetative remediation, other methods for removing said materials will be identified. For construction areas adjacent to creeks and streams, the stormwater's pH must also be moderated prior to discharge.
- **Special BMPs designed to remove concrete or limestone dust particles from stormwater runoff in contact with recycled or rubblized concrete underpavement** must be removed once the stormwater discharging from the site is determined to be clean. This is often several months following completion of the project. The Contractor may have to return to the project area following project completion to remove these BMPs and restore the affected work area.
- **Hazardous Material Spill Response Wastes.** The Contractor shall include as part of their Spill Prevention and Control Plan a description of the procedures for the storage and disposal of regulated hazardous or toxic waste, spill response procedures, and provisions for reporting if there are releases in excess of reportable quantities.

g. Natural Buffers

There are no Waters of the United States, including existing natural buffers, within the project limits or within 100 feet of the project boundaries.

3. Maintenance.

The following is a description of procedures that will be used to maintain, in good and effective operating conditions, vegetation, erosion and sediment control measures and other protective measures identified in this plan:

- **Erosion and Sediment Control Manager (ESCM):** The Contractor shall assign an ESCM to the project. This person is required to have taken an approved sediment and erosion control training course. The ESCM will be responsible for supervising the maintenance of Erosion & Sediment Control measures and implementation of this plan.
- **Temporary Erosion Control Seeding:** Reapply seed if stabilization hasn't been achieved. Apply temporary mulch to hold seed in place if seed has been washed away or found to be concentrated in ditch bottoms. Restore rills as quickly as possible on slopes steeper than 1V:4H to prevent sheet-flow from becoming concentrated flow patterns. Mow, if necessary, to promote seed soil contact when excessive weed development occurs (a common indication of ineffective temporary seeding). Supplement seed if weather conditions (extreme heat or cold) are not conducive to germination.
- **Inlet Protection:** Remove sediment from inlet filter baskets when basket is 25% full or 50% of the fabric pores are covered with silt. Clean filter if standing water is present longer than one hour after a rain event. When there is evidence of sediment accumulation adjacent to the inlet protection, the deposited sediment shall be removed by the end of the day in which it was found or by the end of the following day if removal by the end of the same business day is not feasible. Remove trash accumulated around or on top of inlet protection device. When filter is removed for cleaning, replace fabric if any tear is present.
- **Silt Fence:** Repair tears, gaps or undermining. Restore leaning silt fence and ensure taut. Repair or replace any missing or broken stakes immediately. Clean fence line if sediment reaches one-third height of barrier. Remove fence once final stabilization is established. Repair fence if undermining occurs anywhere along its entire length.
- **Erosion Control Blanket:** Repair damage due to water running beneath the blanket and restore blanket when displacement occurs. Reseeding may be necessary. Replace all displaced blanket and restaple.
- **Solid Waste Management:** Designate a waste collection area(s) and identify them in the SWPPP. Inspect inlets, outfalls and drainage ways for litter, debris, containers, etc. Observe the construction site for improper waste disposal. Update the SWPPP any time the trash management plan significantly changes. Correct items discarded outside of designated areas.

- Vehicle and Equipment Fueling, Cleaning and Maintenance: Cleanup spills immediately. Contractor must provide documentation that spills were cleaned, materials disposed of, and impacts mitigated. Update the SWPPP when designated location has been removed, relocated, added or requires maintenance. In the event of a spill into a storm drain, waterway or onto a paved surface, the owner of the fuel must immediately take action to contain the spill. Once contained, clean up the spill. As an initial step this may involve collecting any bulk material and placing it in a secure container for later disposal. Follow-up cleaning will also be required to remove residues from paved or other hard surfaces.

4. Inspections and Corrective Actions.

The Engineer will be responsible for conducting inspections along with the Contractor's ESCM. A maintenance inspection report will be completed after each inspection. A copy of the report form will be completed by the Engineer and Contractor and will be maintained on site.

Qualified personnel shall inspect disturbed areas of the construction site which have not been finally stabilized, structural control measures, and locations where vehicles enter or exit the site. Such inspection shall be conducted at least once every seven (7) calendar days and within 24 hours of the end of a storm or by the end of the following business or work day that is 0.5 inches or greater or the equivalent snowfall. Inspections may be reduced to once per month when construction activities have ceased due to frozen conditions. Weekly inspections shall recommence when construction activities are resumed, or if there is a 0.50 inches or greater rain event, or a discharge due to snowmelt occurs.

- a. Disturbed areas and areas used for storage of wastes, equipment, and materials shall be inspected for evidence of, or the potential for, pollutants entering the drainage system. Erosion and sediment control measures identified in the plan shall be observed to ensure that they are operating correctly. All locations where stabilization measures have been implemented shall be observed to ensure that they are still stabilized. Where discharge locations or points are accessible, they shall be inspected to ascertain whether erosion control measures are effective in preventing significant impacts to receiving waters. Locations where vehicles enter or exit the site shall be inspected for evidence of offsite sediment tracking. If repair is necessary, it will be initiated within 24 hours of the completion of the inspection report.

If the inspections determine concrete fines are discharging as a result of roadway reconstruction, the Contractor must ensure that the discharge does not exit the right-of-way. The Engineer will immediately test the pH levels of the affected discharge runoff to determine the average pH levels. Where pH levels exceed 9.0, the Engineer will recommend remediation strategy to reduce the alkalinity to acceptable levels before allowing to exit

the right-of-way or discharge to environmentally sensitive locations.

- b.** Based on the results of the inspection, the description of potential pollutant sources identified in Section 1 above, and pollution prevention measures identified in Section 2 above, the Storm Water Pollution Prevention Plan shall be revised as appropriate as soon as practicable after such inspection to minimize discharges. Any changes to this plan resulting from the required inspections shall be implemented within seven (7) calendar days following the inspection.
- c.** A report summarizing the scope of the inspection, name(s), qualifications of personnel making the inspection, the date(s) of the inspection, major observations relating to the implementation of this Storm Water Pollution Prevention Plan, and actions taken in accordance with Section 4.b. above shall be made and retained as part of the plan for at least three (3) years after the date of the inspection. The report shall be signed by the Contractor and the Engineer.
- d.** For any violation of the SWPPP observed during any inspection conducted, including those not required by the plan, and any illicit discharge (defined as any discharge that is not composed entirely of storm water) exiting the right-of-way or to receiving waters, the Engineer will immediately report the incident to the Illinois Tollway Environmental Unit and shall be submitted electronically on the Incidence of Non-Compliance (ION) forms provided by IEPA within 12 hours.

Reports of violations of the SWPPP or illicit discharges shall be reported to the Illinois Tollway Environmental Unit at environment@getipass.com. For additional inquiry, contact (630) 241-6800 ext. 4222. The Illinois Tollway Environmental Unit will coordinate any potential violations directly with the IEPA. In addition, the Engineer will provide a written submission to the Illinois Tollway Environmental Unit and the project files within 5 days summarizing the incident(s) and actions taken.

- e.** Corrective action shall be taken to address any of the following conditions if identified at the site: a stormwater control needs repair or replacement; a stormwater control necessary to comply with the requirements of this permit was never installed or was installed incorrectly; or discharges are causing an exceedance of applicable water quality standards; or a prohibited discharge has occurred.

Corrective actions shall be completed as soon as possible and documented within 7 days of the non-compliance in an inspection report. If it is infeasible to complete the installation or repair within seven (7) calendar days, the inspection report(s) will describe the conditions contributing to the infeasibility to complete the installation or repair within the 7-day timeframe and document the schedule for installing the stormwater control(s) and making them operational as soon as feasible after the 7-day timeframe.

5. Non-Storm Water Discharges.

The following allowable non-stormwater discharges may combine with stormwater discharges that are treated by the measures included in this plan and are anticipated on the project:

Allowable Non-Stormwater Discharges	Likely to be Present on the Site	
	Yes	No
Waters used to wash vehicles where detergents are not used	<input checked="" type="checkbox"/>	<input type="checkbox"/>
Waters used to control dust	<input checked="" type="checkbox"/>	<input type="checkbox"/>
Pavement wash waters where spills or leaks of toxic or hazardous materials have not occurred (unless spilled materials have been removed) and where detergents are not used	<input type="checkbox"/>	<input checked="" type="checkbox"/>
Landscape irrigation drainages	<input type="checkbox"/>	<input checked="" type="checkbox"/>
Uncontaminated groundwater or spring water	<input type="checkbox"/>	<input checked="" type="checkbox"/>
Foundation or footing drains where flows are not contaminated with process materials, such as solvents	<input type="checkbox"/>	<input checked="" type="checkbox"/>
Potable water sources including uncontaminated water main or fire hydrant flushing water	<input type="checkbox"/>	<input checked="" type="checkbox"/>
Discharges from dewatering of trenches and excavations if managed by appropriate controls	<input type="checkbox"/>	<input checked="" type="checkbox"/>

For each allowable non-stormwater discharge anticipated on the project, the measures which will be used to eliminate or reduce the non-stormwater component of the discharge are described below:

- Silt fence shall be installed at the limits of construction to minimize the potential for soil runoff from the site. Care shall be taken for non-stormwater discharges to minimize point source discharge to exposed soil. Contractor shall make all efforts to discharge water non-stormwater discharges as close to an erosion protection device as possible (temporary ditch check, protected drainage swale, or provide sheet drainage across pavement to minimize flow velocities to unprotected areas.

6. Contractor Inventory of Hazardous Materials and Substances.

The materials or substances listed below are expected to be present on site during construction (use additional pages, as necessary). **To be filled in by Contractor.**

7. Contractor Required Submittals.

The Contractor and any subcontractor responsible for compliance with the provisions of the SWPPP shall provide, as an attachment to their signed Contractor Certification Statement, a narrative description of how they will comply with the requirements of the SWPPP with regard to the following items:

- **Stabilized Construction Entrances:** Identify the location(s) of stabilized construction entrances to be used and provide a description of how they will be maintained. Indicate if any changes to the suggested locations (if any) shown on the plans are proposed.
- **Material Delivery, Storage and Use:** Discuss where and how materials, including chemicals, concrete curing compounds, petroleum products, etc. will be stored to prevent spills.
- **Solid Waste Management and Disposal:** Discuss the procedures to be used to contain, and the method of disposal, for construction waste and litter.
- **Sanitary Waste:** Discuss how sanitary wastes will be contained and disposed along with the locations of portable restroom facilities. A schedule of maintenance shall be provided.
- **Spill Response and Control:** Provide a Spill Prevention and Control Plan describing the steps that will be taken to respond to, control, and report chemical or petroleum spills which may occur. Procedures to address spills in excess of RCRA reportable quantities must be provided.

- Vehicle and Equipment Cleaning and Maintenance: Discuss where vehicle and equipment cleaning and maintenance will be performed and the BMPs that will be used for spill containment and spill prevention, containment, and treatment of wash waters.

The above submittals shall be incorporated by reference and become part of the SWPPP.

In addition to the above, the Contractor is required to provide the following submittals to demonstrate compliance with the Illinois Tollway Supplemental Specifications and any federal or state environmental permits:

- Dust Control Plan pursuant to Article 107.36 of the Illinois Tollway Supplemental Specifications. The plan shall be submitted and approved prior to commencement of earth disturbing work activities.
- Erosion and Sediment Control Schedule pursuant to Article 280.02 of the Illinois Tollway Supplemental Specifications. The schedule shall be submitted and approved prior to commencement of earth disturbing work activities.

ILLINOIS TOLLWAY CERTIFICATION STATEMENT

This certification statement is a part of the Storm Water Pollution Prevention Plan for the project described below, in accordance with NPDES Permit No. ILR10, issued by the Illinois Environmental Protection Agency.

Project Information:

Route Elgin O'Hare Western Access TOLLWAY Marked I-490
Section N/A Project No. I-19-4716
County Cook County

I certify under penalty of law that this document and all attachments were prepared under my direction or supervision in accordance with a system designed to assure that qualified personnel properly gathered and evaluated the information submitted. Based on my inquiry of the person or persons who manage the system, or those persons directly responsible for gathering the information, the information submitted is, to the best of my knowledge and belief, true accurate and complete. I am aware that there are significant penalties for submitting false information, including the possibility of fine and imprisonment for knowing violations.

Prepared By: Wood Environment & Infrastructure Solutions, Inc.
DESIGN SECTION ENGINEER

By: Gary Baker, P.E./ Principal Engineer
Name/Title

Dated: 7/7/2020

OWNER: ILLINOIS STATE TOLL HIGHWAY AUTHORITY

Signed:  Environmental Planner
Name/Title

CONTRACTOR CERTIFICATION STATEMENT

This certification statement is a part of the Storm Water Pollution Prevention Plan for the project described below, in accordance with NPDES Permit No. ILR10, issued by the Illinois Environmental Protection Agency.

Project Information:

Route Elgin O'Hare Western Access TOLLWAY Marked I-490
Section N/A Project No I-19-4716
County Cook County

I certify under penalty of law that I understand the terms of the general National Pollutant Discharge Elimination System (NPDES) permit No. ILR10 that authorizes the storm water discharges associated with industrial activity from the construction site identified as part of this certification: That I agree to comply therewith; and that I will ensure that all Subcontractors working on the subject project understand and comply with said permit.

Signature Date

Title
Martinez Frogs, Inc.

Name of Firm
650 Andy Drive

Street Address
Melrose Park Illinois 60160

City State Zip Code

Telephone Number
773.888.5358

ATTACHMENT _____

Note: CONTRACTOR TO COMPLETE

Prepare additional signature pages as needed if the responsibilities of the Storm Water Pollution Prevention Plan are split between contractors - specify which item(s) these sub-contractors assume responsibility for.



Stormwater Pollution Prevention Plan Addendum

BUILDING DEMOLITION **Contract I-19-4716**

11825 Franklin Avenue
Franklin Park, Illinois 60131

PREPARED FOR **Martinez Frogs, Inc.**

650 Andy Drive
Melrose Park, Illinois 60160
Tele: (773) 888-5358

PREPARED BY **True North Consultants, Inc.**

1000 East Warrenville Road,
Suite 140
Naperville, Illinois 60563
Tele: (630) 717-2880

SUBMITTED ON
July 2, 2020

TNC PROJECT NUMBER
T120335

CONTRACTOR REQUIRED SUBMITTALS

Stabilized Construction Entrances

Martinez Frogs, Inc. shall install a stabilized construction entrance in accordance with Article 280.07: Stabilized Construction Entrance of the Supplemental Specifications. The location of the Entrance has been provided on Figure 1 of the SWPP Plan Addendum.

The exit location will continue to be monitored as part of the SWPP Plan inspection process. Any signs of track-off from the site onto the public right-of-way will be removed in a timely fashion.

Material Delivery, Storage and Use

Martinez Frogs, Inc. does not anticipate significant material delivery or storage of hazardous chemicals, petroleum products or other construction-related materials in areas that will be exposed to stormwater during the construction process. In the event that a significant amount of materials is delivered, stored, and used on the site, appropriate measures, inclusive of structural BMPs and designated storage areas, will be provided to prevent spills and releases that may impact stormwater.

Solid Waste Management and Disposal

Based on the nature of the project, demolition activities shall generate solid waste. These waste materials shall be managed on-site by categorizing the type of waste generated in stockpiles. Martinez Frogs, Inc. anticipates that these materials will be live loaded into semi-trailers for transport to their final destination. Based on the material, the waste will either be sent off-site for recycle at an approved recycling facility, placement at a permitted CCDD facility, or disposal at a Subtitle D landfill.

The site will be continually monitored for litter that may be generated from the site or from off-site. Litter shall be removed when necessary and disposed of as a domestic waste.

Sanitary Waste

Martinez Frogs, Inc. shall subcontract a sanitation service to manage on-site restroom facilities. The facilities shall be located in the vicinity of the entrance for convenience purposes. The sanitation service, at a minimum, will remove waste from the restroom units on a monthly basis. Frequency shall be based on crew size and use of the facilities.

Spill Response and Control Plan

The following provides the response actions that will be followed in the event of a spill during on-site activities:

1. Spill Prevention & Clean-up Coordinator

The on-site superintendent has the primary responsibility as the Spill Prevention & Clean-up Coordinator (Coordinator). In his/her absence, the on-site supervisor will assume primary responsibility for emergency actions, response and coordination of response resources. The superintendent and automotive division Supervisor contact information is located in Section 2.0 of this SPCC Plan.

2. Evaluation of the Emergency

In the event of a spill, the Coordinator must identify the character, exact source, amount and extent of any released materials. This may be done by observation, review of facility records, or chemical analysis if necessary. The spill shall be documented on the Contractor daily log.

3. Assessment of Hazards

In the event of a spill, the Coordinator must assess the possible hazards to human health or to the environment that may result from the release. This assessment must consider both the direct and indirect effects of the emergency in planning the response.

4. Spill Response Procedures

This section has been developed and incorporated into this Spill Response and Control Plan so that spill response procedures can be easily followed in the event of a spill. For the purposes of this plan, a spill is defined as any spilling, leaking, pumping, pouring, emitting, discharging, injecting, escaping, leaching, dumping, or disposing into the environment of any oil or oil-like substances. Any spill that enters the navigable waters of the United States or the adjoining shorelines in harmful quantities must be reported. A harmful quantity of oil causes a film or sheen upon the water or adjoining shorelines, discolors the water or adjoining shorelines, or causes an emulsion or sludge to be deposited beneath the surface of the water or the adjoining shorelines. The navigable water includes all ditches, streams, creeks, lakes and ponds connected to the tributary system in a river basin. If any untreated oil enters the sanitary sewer after a spill, it must be reported. Any catastrophic event (earthquake, tornado, vehicle crash into tanks) needs to be reported immediately to the appropriate agencies, and then follow the directions given by the agency.

The Coordinator shall document the spill after each discharge occurrence. This information shall be used to report the discharge to the proper response agencies. Information in step 5 below presents emergency telephone numbers and related response agency telephone numbers.

The EPA does not consider a release to have occurred if the release of the oil or petroleum product is completely contained in a secondary containment or within a building or structure. Concurrently, a spill or release of a petroleum product, which is cleaned up before it enters a drain, reaches a navigable waterway, or groundwater, does not require reporting under IEPA guidelines.

The following procedures must be followed in the event of a spill.

4.1 Notification of a Spill

Upon the discovery of a spill, the proper notifications must be made. The Coordinator must be notified immediately upon discovery. In order to properly respond to, report, and document a spill, the following steps have been established:

- | | |
|--------|--|
| Step 1 | Protect yourself and others. |
| Step 2 | Take immediate corrective action. |
| Step 3 | The person who discovers the spill must initially notify the Coordinator or designee and inform them of the nature of the spill. Names and numbers are listed in the SWPP Plan in page J-28. |
| Step 4 | The Coordinator or designee must then record the date and time that the spill was reported, evaluate the need for spill response and, as needed, dispatch a clean-up crew. |

Step 5 The Coordinator or the designee is responsible for proper notification to Federal, State, and local agencies as specified below. The Coordinator will then notify all individuals required to secure and contain the spill, and to initiate cleanup procedures.

In the event of a discharge of a harmful quantity, of oil to the storm sewer, sanitary sewer, or drainage swales leading off-site, the facility must report immediately (within 15 minutes of detection) to the following agencies:

National Response Center (NRC)
(800) 424-8802 or (202) 426-2675

Illinois Emergency Management Agency
(800)782-7860

Metropolitan Water Reclamation District of Greater Chicago
(312) 787-3575

A “harmful quantity” is defined in 40 CFR Section 112.3 as a discharge of oil into or upon the navigable waters of the U.S. or adjoining shorelines in such quantities that it has been determined may be harmful to the public health or welfare, including discharges that:

- 1) Violate applicable water quality standards, or
- 2) Cause a film or sheen upon or discoloration of the water or adjoining shorelines, or cause a sludge or emulsion to be deposited beneath the surface of the water or upon adjoining shorelines.

Step 6 The Coordinator or designee must properly document the spill. A spill information form is provided in Attachment A.

Step 7 Following a reportable spill, the Coordinator will conduct a post-spill review. During such review, the on-site personnel will investigate and review the incident and prepare documentation of the incident. Specifically, the review will entail all measures required to identify the cause of the incident, determine how to correct the incident and prevent the incident from reoccurring.

4.2 Disposal Methods

The spill material and all material used to clean-up or mitigate a spill shall be managed and disposed by a qualified environmental waste management company. Prior to disposal of the material, the Coordinator shall secure disposal approval from the disposal facility. The waste material shall be managed under waste tracking procedures to verify appropriate disposal activities.

Vehicle and Equipment Cleaning and Maintenance

Martinez Frogs, Inc. does not anticipate the need for vehicle cleaning or maintenance on-site during the project, based on the short duration. In the event that machine maintenance is required during the

project, maintenance activities will be performed at locations that minimize the threat for environmental impact. Spill containment, if necessary based on the maintenance activity, shall be managed using spill prevention measures provided by maintenance personnel.

FIGURES, NOTES, & DETAILS

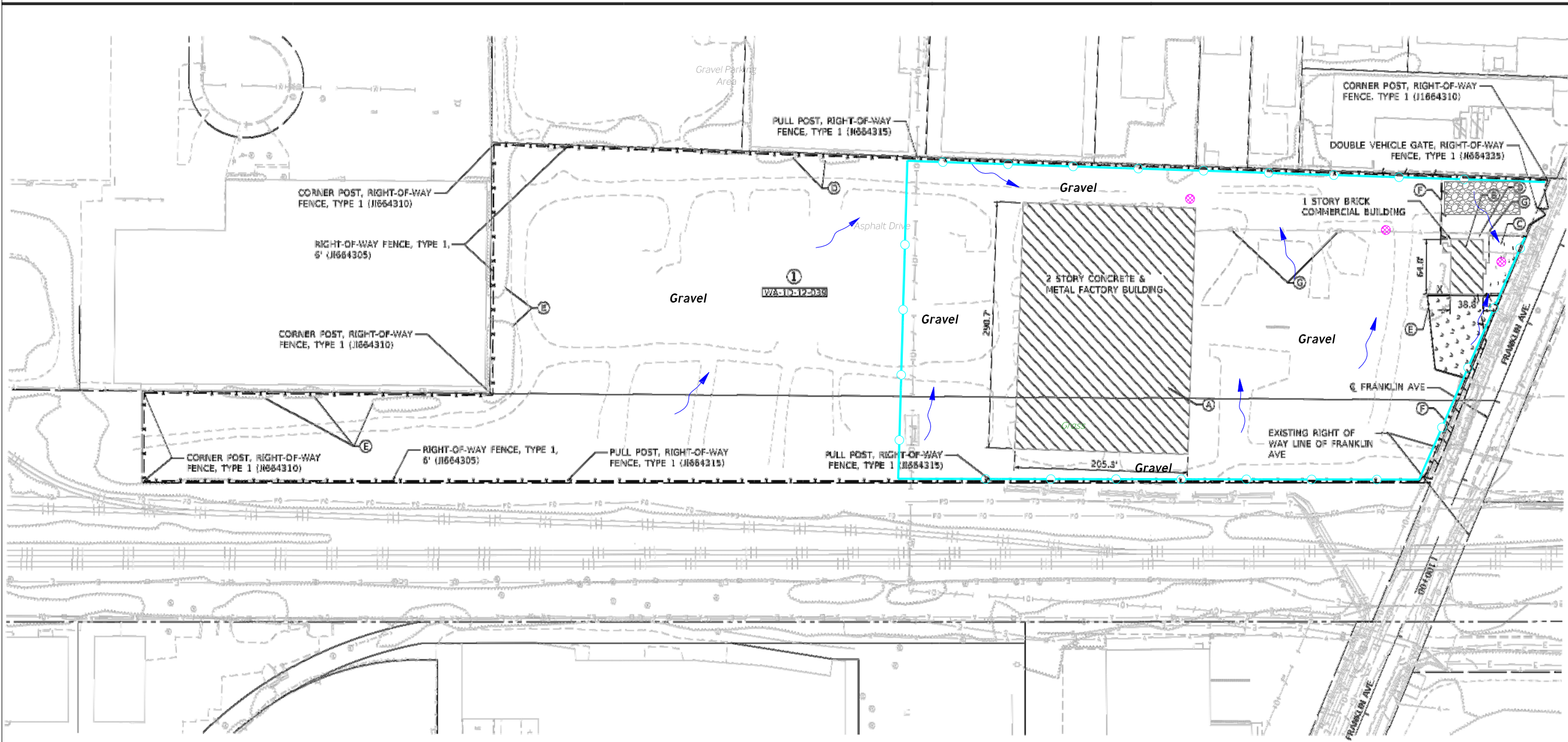

BUILDING REMOVAL NO. 1 (TOLLWAY PIN WA-1D-12-039).
 - PARCEL PINS: 12-19-100-031 & 12-19-100-043
 - 11823 FRANKLIN AVE
 - COOK COUNTY, BENSenville, IL 60131

NOTE:
 CONTRACTOR TO LOCATE PROPERTY PINS AS DESCRIBED IN LEGAL PLATS.
 APPROX. EXISTING GROUND EL. = 560.00
 APPROX. PROPOSED ULTIMATE EL. = 560.00

FOR INFORMATION ONLY

(A)	BUILDING REMOVAL NO. 1:	59,586 SQ FT
(B)	BUILDING REMOVAL NO. 2:	2,654 SQ FT
(C)	HMA PAVEMENT (REIN):	2,265 SQ FT
(D)	SIDEWALK (REIN):	500 SQ FT
(E)	VEGETATION (REIN):	0.25 AC
(F)	EX. FENCE (REIN):	428 FOOT
(G)	EX. UTILITY POLE (REIN):	3 SACH
(H)	TREE (REIN):	2 SACH

LEGEND

- (X) BUILDING REMOVAL NUMBER
- [Hatched Box] BUILDING LOCATION
- [Dashed Line] VEGETATION LIMITS
- [Solid Line] LINEAR REMOVAL
- (X) TREE REMOVAL
- [Hatched Box] HMA PAVEMENT REMOVAL
- [Dashed Line] RIGHT-OF-WAY FENCE, TYPE 1, 6'
- [Stippled Box] MOWING (SPECIAL)

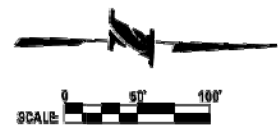

LEGEND

- [Blue Arrow] Predicted Stormwater Flow Direction
- [Red Line] Silt Fence Location
- [Pink Circle with X] Identified Stormwater Catch Basin with Filter Fabric Inlet Protection, Basket Type
- [Stippled Box] Stone Stabilized Construction Entrance Location

All location are approximate.
 Presented information based on existing conditions provided in the Tollway Specification Plans prepared by Collins Engineering dated 01/14/20.



TRUENORTH CONSULTANTS
 1000 East Warrenville Road, Suite 140
 Naperville, Illinois 60563
 ENVIRONMENT : INFRASTRUCTURE : DEVELOPMENT

CLIENT: Martinez Frogs, Inc.
 650 Andy Drive
 Melrose Park, Illinois 60160

TITLE: Stormwater Pollution Prevention Plan
 Tollway Contract I-19-4716

DRAWN BY: RML
DATE: 07/02/20
JOB NUMBER: T120335

FIGURE 1

GENERAL NOTES - EROSION AND SEDIMENT CONTROLS

1. THE WORK DESCRIBED ON THESE DRAWINGS IS AN INTEGRAL PART OF THE STORM WATER POLLUTION PREVENTION PLAN USED TO OBTAIN AN NPDES PERMIT FROM IEPA FOR THE CONSTRUCTION OF THIS PROJECT.
2. THE PURPOSE OF THE EROSION AND SEDIMENT CONTROL MEASURES INCLUDED FOR THIS PROJECT IS TO LIMIT THE SEDIMENT POLLUTION IMPACT OF ANY STORM WATER DISCHARGES THAT ORIGINATE ON THIS SITE OR OFF-SITE FLOWS THAT FLOW OVER THE DISTURBED AREAS.
3. IT IS THE RESPONSIBILITY OF THE CONTRACTOR TO ENSURE THAT SEDIMENT TRANSPORT OFF THE SITE IS REDUCED BY A COMBINATION OF MINIMIZATION OF EROSION AT THE SOURCE AND INSTALLATION OF SPECIFIC MEASURES TO CONTROL OR REDUCE THE TRANSPORT OF SEDIMENT. A COPY OF THE EROSION AND SEDIMENT CONTROL PLAN, NOI, SWPPP, AND INSPECTION LOG BEING IMPLEMENTED BY THE CONTRACTOR SHALL BE ON THE CONSTRUCTION SITE AT ALL TIMES.
4. TO THE MAXIMUM EXTENT POSSIBLE EROSION SHALL BE MINIMIZED AT THE SOURCE. ALL FLOWS ORIGINATING OFF THE CONSTRUCTION SITE SHALL BE DIVERTED AROUND DISTURBED AREAS OR SHALL BE CONVEYED THROUGH THE SITE IN A MANNER THAT UNTREATED ON-SITE RUNOFF, SHALL BE MINIMIZED AND DOES NOT MIX WITH THE OFF-SITE RUNOFF.
5. ALL RUNOFF ORIGINATING ON DISTURBED AREAS ASSOCIATED WITH THIS PROJECT SHALL PASS THROUGH ONE OR MORE MEASURES THAT SHALL MINIMIZE THE OFF-SITE SEDIMENT IMPACTS OF THE CONSTRUCTION ACTIVITY.
6. ALL PERMANENT SEDIMENT BASINS, PERMANENT STORM WATER CONTROL MEASURES, PERIMETER SILT FENCE, AND RUNOFF CONTROL MEASURES REQUIRED TO KEEP OFF-SITE RUNOFF FROM FLOWING OVER THE CONSTRUCTION AREA SHALL BE INSTALLED BEFORE CLEARING AND STRIPPING OF THE SITE PROCEEDS. PRIOR TO PROCEEDING WITH EARTHWORK ON A PROJECT THE CONTRACTOR SHALL SUBMIT TO THE ENGINEER A PROPOSED EARTHWORK AND STABILIZATION SCHEDULE FOR REVIEW AND APPROVAL.
7. A MAXIMUM OF 10 ACRES IS ALLOWED TO BE IN SOME STAGE OF GRADING AT A SINGLE TIME. ADDITIONAL AREAS (UP TO 10 ACRES) MAY BE CLEARED BUT SHALL NOT BE STRIPPED OF VEGETATION UNTIL THE GRADED AREAS HAVE BEEN PROTECTED FROM EROSION THROUGH INSTALLATION OF EITHER TEMPORARY OR PERMANENT MEASURES. WHENEVER POSSIBLE, THE GRADING SHALL BE COMPLETED TO THE DESIGN GRADE AND THE PERMANENT VEGETATION PLAN IMPLEMENTED PRIOR TO STARTING GRADING ACTIVITIES ON THE NEXT SITE.
 - A. WHEN BALANCING EARTHWORK (BORROW FROM A CUT USED AS FILL AT A LOCATION DISTANT FROM THE CUT) THE CHIEF ENGINEER MAY ALLOW MORE THAN 10 ACRES OF CONSTRUCTION WORK AREAS AND STORAGE AREAS.
 - B. WHERE NEW INTERCHANGES ARE BEING CONSTRUCTED THE ALLOWABLE AREA BEING GRADED MAY BE LARGER THAN 10 ACRES WHEN THE CONTRACT DRAWINGS AND SWPPP DEFINE SUCH INCREASES.
 - C. VARIATIONS TO THE ABOVE MAY BE CONSIDERED BY THE CHIEF ENGINEER UNDER ALL THE FOLLOWING CONDITIONS:
 - IF THE CONTRACTOR FALLS BEHIND SCHEDULE THROUGH NO FAULT OF HIS OWN.
 - THE CONTRACTOR SHALL PRESENT A SCHEDULE DEMONSTRATING THE NEED FOR SUCH VARIATION IN ORDER TO COMPLETE THE WORK ON TIME.
 - THE CONTRACTOR SHALL COMPLY WITH ALL OTHER CONTRACT AND PERMIT REQUIREMENTS.
8. STABILIZATION OF DISTURBED AREAS SHALL, AT A MINIMUM, BE INITIATED IMMEDIATELY WHENEVER ANY CLEARING, GRADING, EXCAVATING, OR OTHER EARTH DISTURBING ACTIVITIES HAVE PERMANENTLY CEASED ON ANY PORTION OF THE

- SITE, OR TEMPORARILY CEASED ON ANY PORTION OF THE SITE AND SHALL NOT RESUME FOR A PERIOD EXCEEDING 14 CALENDAR DAYS. STABILIZATION OF DISTURBED AREAS SHALL BE INITIATED WITHIN 1 WORKING DAY OF PERMANENT OR TEMPORARY CESSATION OF EARTH DISTURBING ACTIVITIES AND SHALL BE COMPLETED AS SOON AS POSSIBLE BUT NOT LATER THAN 14 DAYS FROM THE INITIATION OF STABILIZATION WORK IN AN AREA. WHERE THE INITIATION OF STABILIZATION MEASURES IS PRECLUDED BY SNOW COVER, STABILIZATION MEASURES SHALL BE INITIATED AS SOON AS PRACTICABLE.
9. STABILIZATION OF CUT OR FILL SLOPES WITH TEMPORARY OR PERMANENT EROSION CONTROL MEASURES IS REQUIRED WHENEVER THE CUT OR FILL ACTIVITY REACHES 15 FEET VERTICALLY OR THE FINISHED SLOPE EQUALS 50 FEET, WHICHEVER IS MORE RESTRICTIVE. ONCE THE STABILIZATION MEASURES ARE INSTALLED, THE PLACEMENT OF FILL OR EXCAVATION ACTIVITIES ARE ALLOWED TO PROCEED.
10. THE CONTRACTOR SHALL DESIGNATE ONE OF HIS EMPLOYEES AS EROSION AND SEDIMENT CONTROL MANAGER. THIS PERSON SHALL BE RESPONSIBLE FOR IMPLEMENTATION OF THE EROSION AND SEDIMENT CONTROL PLAN ON ALL DISTURBED AREAS. THIS PERSON SHALL POSSESS THE NECESSARY TRAINING AND CERTIFICATION ON EROSION AND SEDIMENT CONTROL MEASURES FOR ACCEPTANCE BY THE ILLINOIS TOLLWAY. THIS EMPLOYEE IS TO HAVE THE AUTHORITY TO CARRY OUT THE IMPLEMENTATION OF ANY INSTRUCTIONS CONCERNING THE EROSION AND SEDIMENT CONTROL PLAN GIVEN BY THE ENGINEER. ALL MEASURES SHALL BE INSPECTED BY THIS INDIVIDUAL AND THE ENGINEER ON A REGULAR BASIS (AT LEAST ONCE EVERY 7 DAYS) AND AFTER ANY RAINFALL EVENT GREATER THAN 0.5 INCHES, OR EQUIVALENT SNOWFALL (I.E. + 5").
11. SEDIMENT TRAPS, SEDIMENT BASINS, DITCHES, SILT FENCES, FENCES, STONE OUTLET STRUCTURES, EARTH BERMS, ETC. SHALL BE MAINTAINED DURING THE CONSTRUCTION SEASON AS WELL AS THE WINTER MONTHS AND OTHER TIMES WHEN THE PROJECT IS CLOSED DOWN. TRAPS SHALL BE CLEANED WHEN THEY ARE 50% FILLED. SILT FENCE AND STONE OUTLET STRUCTURES SHALL HAVE SEDIMENT REMOVED WHEN IT REACHES 50% THE HEIGHT OF THE CONTROL DEVICE. THESE SPOILS SHALL BE REMOVED TO AN APPROVED SITE.
12. SALVAGED TOPSOIL SHALL BE PLACED ON WELL DRAINED LAND AWAY FROM INTERMITTENT AND LIVE STREAMS OR WETLANDS WITH THE APPROPRIATE RUNOFF CONTROL AND SEDIMENT CONTROL MEASURES INSTALLED AROUND THE STORAGE SITE. SALVAGED TOPSOIL SHALL BE STABILIZED WITH STRAW MULCH IMMEDIATELY AFTER SHAPING OF THE PILE IN ACCORDANCE WITH THE ILLINOIS TOLLWAY SUPPLEMENTAL SPECIFICATIONS. SILT FENCE SHALL BE PROVIDED AT THE PERIMETER OF THE STOCKPILE.
13. MATERIALS EXCAVATED FOR THE CONSTRUCTION OR CLEAN OUT OF SEDIMENT TRAPS SHALL NOT BE STOCKPILED IN THE VICINITY OF THE TRAP. IT SHALL BE PLACED IN AN EMBANKMENT OR WASTED AS DIRECTED BY THE ENGINEER.
14. EXCAVATION TO BE USED FOR EMBANKMENTS SHALL NOT BE STOCKPILED UNLESS PERIMETER CONTROLS ARE UTILIZED. WHEN THIS MATERIAL IS STOCKPILED FOR THE CONVENIENCE OF THE CONTRACTOR THE COST OF PROVIDING THE CONTROLS ARE THE RESPONSIBILITY OF THE CONTRACTOR. IF THE MATERIAL IS STOCKPILED AT THE DIRECTION OF THE ENGINEER THE ILLINOIS TOLLWAY SHALL ASSUME THE COSTS OF THE CONTROLS.
15. SEDIMENT LADEN DEWATERING DISCHARGE SHALL BE DIRECTED TO AN APPROVED SEDIMENT TRAPPING MEASURE PRIOR TO RELEASE FROM THE SITE.

16. ALL EROSION AND SEDIMENT CONTROL MEASURES ARE TO BE CONSIDERED TEMPORARY. THESE MEASURES SHALL BE REMOVED BY THE CONTRACTOR AS DESIGNATED ON THE PLANS OR AS DIRECTED BY THE ENGINEER. DISTURBED AREAS SHALL BE RESTORED UPON REMOVAL.
17. WHEN THE CONTRACTOR REQUESTS A CHANGE TO POSTPONE COMPLETION OF THE EXCAVATION OF A SPECIFIC AREA AS A CONTINUOUS OPERATION AND PLACING THE TOPSOIL AS DEFINED IN THE STANDARD SPECIFICATIONS, THE ENGINEER MAY ALLOW THE CONTRACTOR TO STABILIZE THE AREA USING TEMPORARY STABILIZATION WITH STRAW MULCH PROVIDED THE FOLLOWING CONDITIONS ARE MET:
 - A. ALL AREAS BEING STABILIZED ARE 1:3 (V:H) SLOPES OR FLATTER.
 - B. THE COST OF PREPARING THE SEED BED AND STABILIZING THE AREA WITH TEMPORARY STABILIZATION WITH STRAW MULCH IS THE RESPONSIBILITY OF THE CONTRACTOR.
 - C. ALL REQUIRED SEDIMENT CONTROL MEASURES FOR THE SECTION OF ROAD IN QUESTION HAVE BEEN INSTALLED AND ARE BEING MAINTAINED.
18. THE CONTRACTOR SHALL PREPARE A SKETCH SHOWING DIMENSIONS FROM TWO ADJACENT OBJECTS TO ALL DRAINAGE STRUCTURES THAT HAVE BEEN PROTECTED. THIS IS TO LOCATE THE STRUCTURE IN CASE OF HEAVY RAINFALL AND THE STRUCTURE IS BLOCKED OR FLOODED. THE ENGINEER SHALL BE PROVIDED WITH A COPY OF THE SKETCH.
19. THE CONTRACTOR SHALL CONDUCT HIS OPERATIONS IN ACCORDANCE WITH THE STANDARD DRAWINGS AND SPECIAL PROVISION (S.P.) 111, STORM WATER POLLUTION PREVENTION PLAN INCLUDING CONTROLS AND SPILL PREVENTION-MATERIAL MANAGEMENT PRACTICES. THE CONTRACTOR AND ALL SUBCONTRACTORS SHALL SIGN THE CONTRACTOR'S CERTIFICATION STATEMENT. LIST THE MATERIALS OR SUBSTANCES EXPECTED TO BE PRESENT ON-SITE IN THE INVENTORY FOR POLLUTION PREVENTION PLAN AND SHALL NAME TWO ADDITIONAL INDIVIDUALS TO ASSIST IN SPILL PREVENTION AND CLEAN UP AT THE PRECONSTRUCTION CONFERENCE. SEE S.P. 111.
20. AT THE TIME OF THE PRECONSTRUCTION CONFERENCE, THE CONTRACTOR SHALL SUBMIT FOR APPROVAL THE PROPOSED CONCRETE TRUCK WASHOUT LOCATIONS AS REQUIRED IN SPECIAL PROVISION 111. RUNOFF FROM WASH AREAS SHALL BE CONTAINED IN DESIGNATED AREAS SO THAT RUNOFF DOES NOT REACH THE STORM SEWER OR DITCH SYSTEMS. WASHOUT WATER SHALL BE TAKEN TO AN APPROVED DISCHARGE LOCATION.
21. IF AN ALTERNATIVE SIZE DITCH CHECK IS PROPOSED BY THE CONTRACTOR FOR USE ON THE PROJECT, A CONTRACT DITCH CHECK SPACING SHALL BE RECALCULATED BY THE CONTRACTOR IN ACCORDANCE WITH THE ILLINOIS TOLLWAY EROSION AND SEDIMENT CONTROL, LANDSCAPE DESIGN CRITERIA MANUAL. ANY RESULTING QUANTITY CHANGES SHALL BE APPROVED BY THE ENGINEER PRIOR TO START OF WORK.
22. ALL RUNOFF, EROSION AND SEDIMENT CONTROL MEASURES SHALL BE LOCATED OUTSIDE THE CLEAR ZONE. THE CONTRACTOR SHALL REVIEW THE LOCATIONS OF ALL MEASURES AND PERFORM A BARRIER WARRANT ANALYSIS IF NECESSARY TO ENSURE ROADSIDE OBSTACLES ARE NOT CREATED.
23. ALL SLOPES ARE EXPRESSED AS UNITS OF VERTICAL DISPLACEMENT TO UNITS OF HORIZONTAL DISPLACEMENT (V:H).















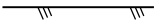

TEMPORARY EROSION AND SEDIMENT CONTROLS

STANDARD K1-08

DATE	REVISIONS
3-31-2014	REVISED GENERAL NOTES.
3-11-2015	REVISED NOTES.
3-31-2016	REMOVED TEMPORARY DITCH CHECKS
3-01-2018	REVISED BUFFER WIDTHS AND DETAIL.
3-01-2019	REVISED FABRIC INLET PROTECTION AND STABILIZED CONSTRUCTION ENTRANCE.

 APPROVED..... DATE 2-7-2012...
 CHIEF ENGINEERING OFFICER

STANDARD SYMBOLS

	CLEARING & GRADING LIMITS (LIMITS OF CONSTRUCTION)		SILT FENCE
	CULVERT INLET PROTECTION-FENCE		STABILIZED CONSTRUCTION ENTRANCE
	CULVERT INLET PROTECTION-STONE		STONE OUTLET STRUCTURE SEDIMENT TRAP
	CIP		STREAM DIVERSION
	DEWATERING BASINS		SUPER SILT FENCE
	DIVERSION DIKE		TEMPORARY DITCH CHECK
	DRAINAGE DIVIDE		TEMPORARY PIPE SLOPE DRAIN
	EXISTING DRAINAGE PATH		TEMPORARY RIPRAP
	FILTER FABRIC INLET PROTECTION, COVER TYPE		TEMPORARY ROCK CHECK DAM
	FILTER FABRIC INLET PROTECTION, BASKET TYPE		TEMPORARY STREAM CROSSING
	FLOTATION BOOM		TEMPORARY SWALE
	INITIAL CONSTRUCTION ITEM		TREE PROTECTION
	PROPOSED DRAINAGE PATH		
	RECTANGULAR INLET PROTECTION		
	SEDIMENT BASIN AGGREGATE BERM		
	SEDIMENT BASIN		

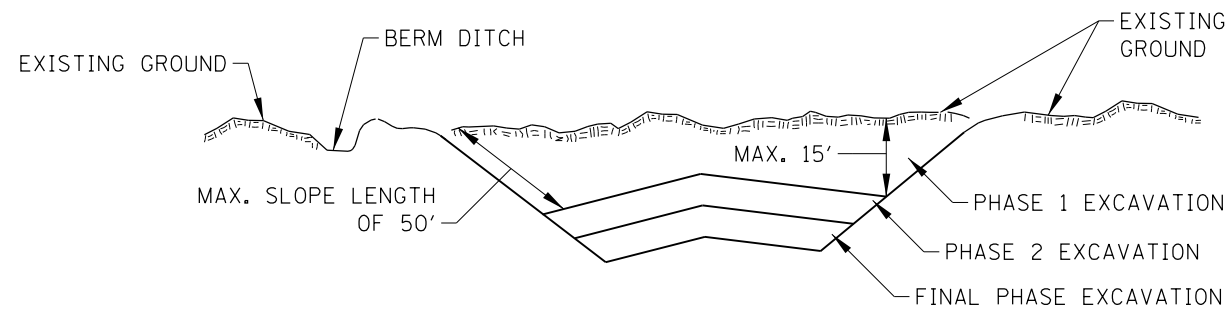

NOTES:

1. ALL CUT SLOPES SHALL BE EXCAVATED AND STABILIZED (PLACE TOPSOIL, PREPARE SEEDBED, APPLY SEED, PROTECT SLOPE WITH MULCH OR EROSION BLANKET) AS THE WORK PROGRESSES.
2. CONSTRUCTION SEQUENCE:
 - A) EXCAVATE AND STABILIZE BERM, SIDE AND OUTLET DITCHES, PROVIDE SEDIMENT TRAPS FOR DITCHES.
 - B) PERFORM PHASE 1 EXCAVATION AND STABILIZE SLOPES WITH PERMANENT SEEDING.
 - C) PERFORM PHASE 2 EXCAVATION AND STABILIZE SLOPES WITH PERMANENT SEEDING. OVER SEED PHASE 1 SLOPES, IF REQUIRED.
 - D) PERFORM FINAL PHASE EXCAVATION, DRESS, SEED AND MULCH SLOPES WITH PERMANENT SEEDING. STABILIZE SURFACE DRAIN DITCHES. OVER SEED PHASE 1 & 2 SLOPES, IF REQUIRED, AS DETERMINED BY THE ENGINEER.
3. IF PERMANENT SEEDING CANNOT BE PLACED DUE TO CONTRACT REQUIREMENTS REGARDING PLANTING SEASONS, THE CUT SLOPE IS TO HAVE TOPSOIL PLACED AND SEEDING PREPARED PRIOR TO USING TEMPORARY STABILIZATION WITH STRAW MULCH OR TEMPORARY SEEDING WITH EROSION BLANKET.
4. THE CONTRACTOR HAS THE OPTION OF DELAYING TOPSOIL SEEDING BEYOND THE 15 FOOT LIMITATION. IF THIS OPTION IS CHOSEN, THE CUT SLOPE MUST BE "TEMPORARY STABILIZED" AT NO COST TO THE ILLINOIS TOLLWAY.
5. ONCE THE EXCAVATION WITHIN A SPECIFIC AREA HAS BEGUN, THE OPERATION SHALL BE CONTINUOUS FROM STRIPPING THROUGH THE COMPLETION OF THE GRADING AND PLACEMENT OF SLOPE STABILIZATION MEASURES. ANY INTERRUPTIONS IN THE OPERATION OF 14 DAYS OR MORE MUST BE APPROVED BY THE ENGINEER. ANY VIOLATION OF THIS REQUIREMENT WILL RESULT IN THE CONTRACTOR ASSUMING THE RESPONSIBILITY OF PLACING TEMPORARY STABILIZATION AT HIS OWN COST AND EXPENSE.

EXCAVATION PHASING PLAN - CUT SECTION

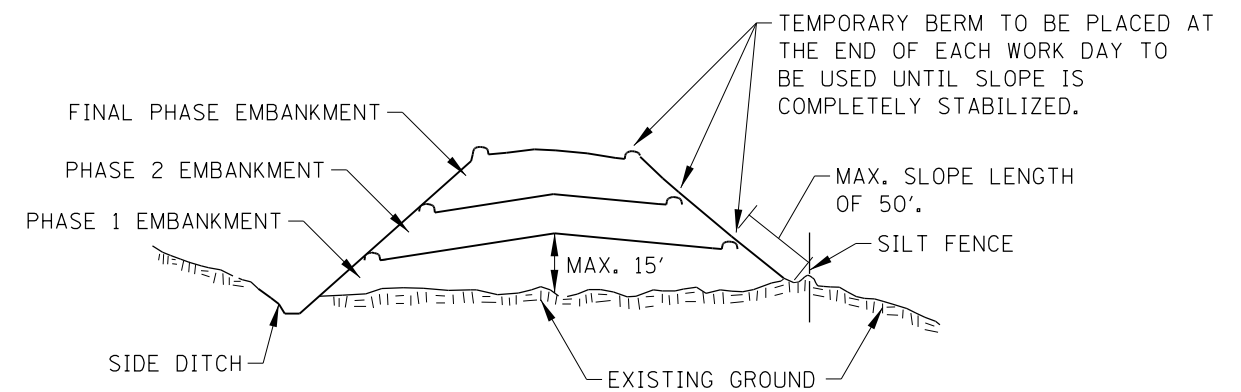

NOTES:

1. THE EMBANKMENT WILL BE MADE IN STAGES NOT TO EXCEED 15' IN HEIGHT OR 50' IN SLOPE LENGTH. THE EMBANKMENT SLOPES WILL BE STABILIZED USING TEMPORARY MEASURES BEFORE BEGINNING NEXT STAGE.
2. AT THE END OF EACH WORK DAY TEMPORARY BERMS (EARTH) AND TEMPORARY PIPE SLOPE DRAINS WILL BE CONSTRUCTED ALONG THE TOP EDGE(S) OF THE EMBANKMENT TO INTERCEPT SURFACE RUNOFF.
3. CONSTRUCTION SEQUENCE:
 - A) EXCAVATE AND STABILIZE SIDE DITCH AND/OR INSTALL PROPOSED PERIMETER CONTROLS AT THE TOE OF SLOPE.
 - B) PLACE PHASE 1 EMBANKMENT AND STABILIZE WITH TEMPORARY SEEDING AND MULCH.
 - C) PLACE PHASE 2 EMBANKMENT AND STABILIZE WITH TEMPORARY SEEDING AND MULCH.
 - D) PLACE FINAL PHASE EMBANKMENT AND STABILIZE WITH PERMANENT VEGETATIVE PLAN ON THE ENTIRE SLOPE.
4. ONCE THE PLACEMENT OF FILL WITHIN A SPECIFIC AREA HAS BEGUN, THE OPERATION SHALL BE CONTINUOUS FROM STRIPPING THROUGH THE COMPLETION OF THE GRADING AND PLACEMENT OF PERMANENT VEGETATIVE PLAN. ANY INTERRUPTIONS IN THE OPERATION OF 14 DAYS OR MORE MUST BE APPROVED BY THE ENGINEER. ANY VIOLATION OF THIS REQUIREMENT WILL RESULT IN THE CONTRACTOR ASSUMING THE RESPONSIBILITY OF PLACING TEMPORARY STABILIZATION AT HIS OWN COST AND EXPENSE.

EMBANKMENT PHASING PLAN - FILL SECTION



TEMPORARY EROSION AND SEDIMENT CONTROLS

STANDARD K1-08

APPROVED: *Paul Kovacs* DATE 2-7-2012
CHIEF ENGINEERING OFFICER

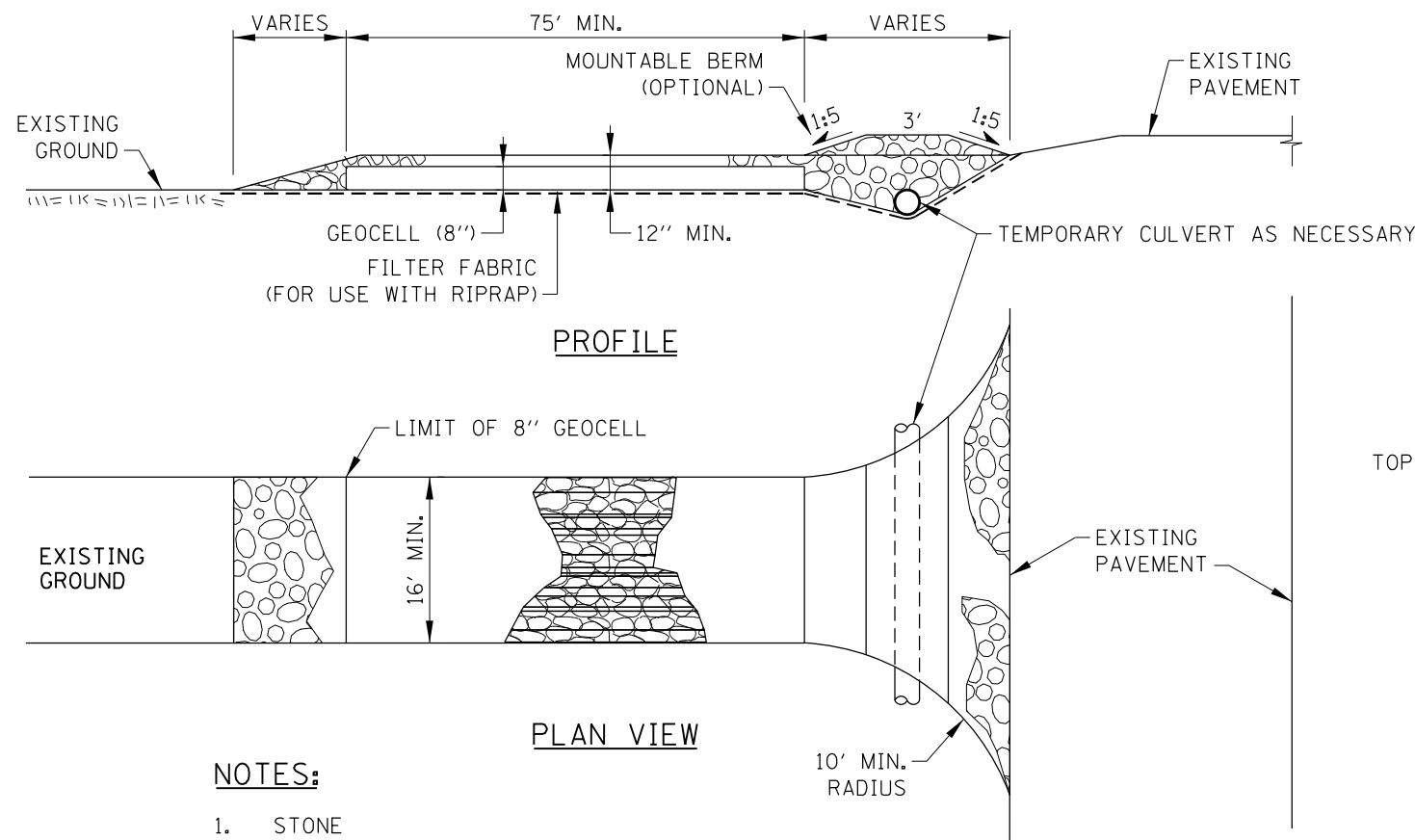

NOTES:

1. STONE
 - A. STONE SIZE - CA-3
 - B. LENGTH - AS REQUIRED, BUT NOT LESS THAN 75'.
 - C. THICKNESS - NOT LESS THAN 4" ABOVE TOP OF GEOCELL.
2. WIDTH - 16' MINIMUM FOR ONE WAY TRAFFIC; 24' MINIMUM FOR TWO-WAY TRAFFIC; BUT NOT LESS THAN THE FULL WIDTH AT POINTS WHERE INGRESS OR EGRESS OCCURS.
3. GEOCELL NOT LESS THAN 8" IN DEPTH WILL BE PLACED OVER THE ENTIRE AREA PRIOR TO PLACING OF STONE.
4. SURFACE WATER - ALL SURFACE WATER FLOWING OR DIVERTED TOWARD CONSTRUCTION ENTRANCES SHALL BE PIPED ACROSS THE ENTRANCE. IF PIPING IS IMPRACTICAL, A MOUNTABLE BERM WITH 1:5 SLOPES WILL BE PERMITTED.
5. MAINTENANCE - THE ENTRANCE SHALL BE MAINTAINED IN A CONDITION WHICH SHALL PREVENT TRACKING OR FLOWING OF SEDIMENT ONTO PUBLIC RIGHTS-OF-WAY. THIS MAY REQUIRE PERIODIC TOP DRESSING WITH ADDITIONAL STONE AS CONDITIONS DEMAND AND REPAIR AND/OR CLEAN OUT OF ANY MEASURES USED TO TRAP SEDIMENT. ALL SEDIMENT SPILLED, DROPPED, WASHED OR TRACKED ONTO PUBLIC RIGHTS-OF-WAY SHALL BE REMOVED IMMEDIATELY.
6. PERIODIC INSPECTION AND NEEDED MAINTENANCE SHALL BE PROVIDED AFTER HEAVY USE AND EACH RAINFALL EVENT.
7. TO BE USED TO REDUCE OR ELIMINATE TRACKING OF SEDIMENT ONTO PUBLIC STREETS. PLACE AT ALL POINTS OF CONSTRUCTION INGRESS AND EGRESS. DISTURBED AREAS TO BE RESTORED UPON REMOVAL.

STABILIZED CONSTRUCTION ENTRANCE
STANDARD SYMBOL

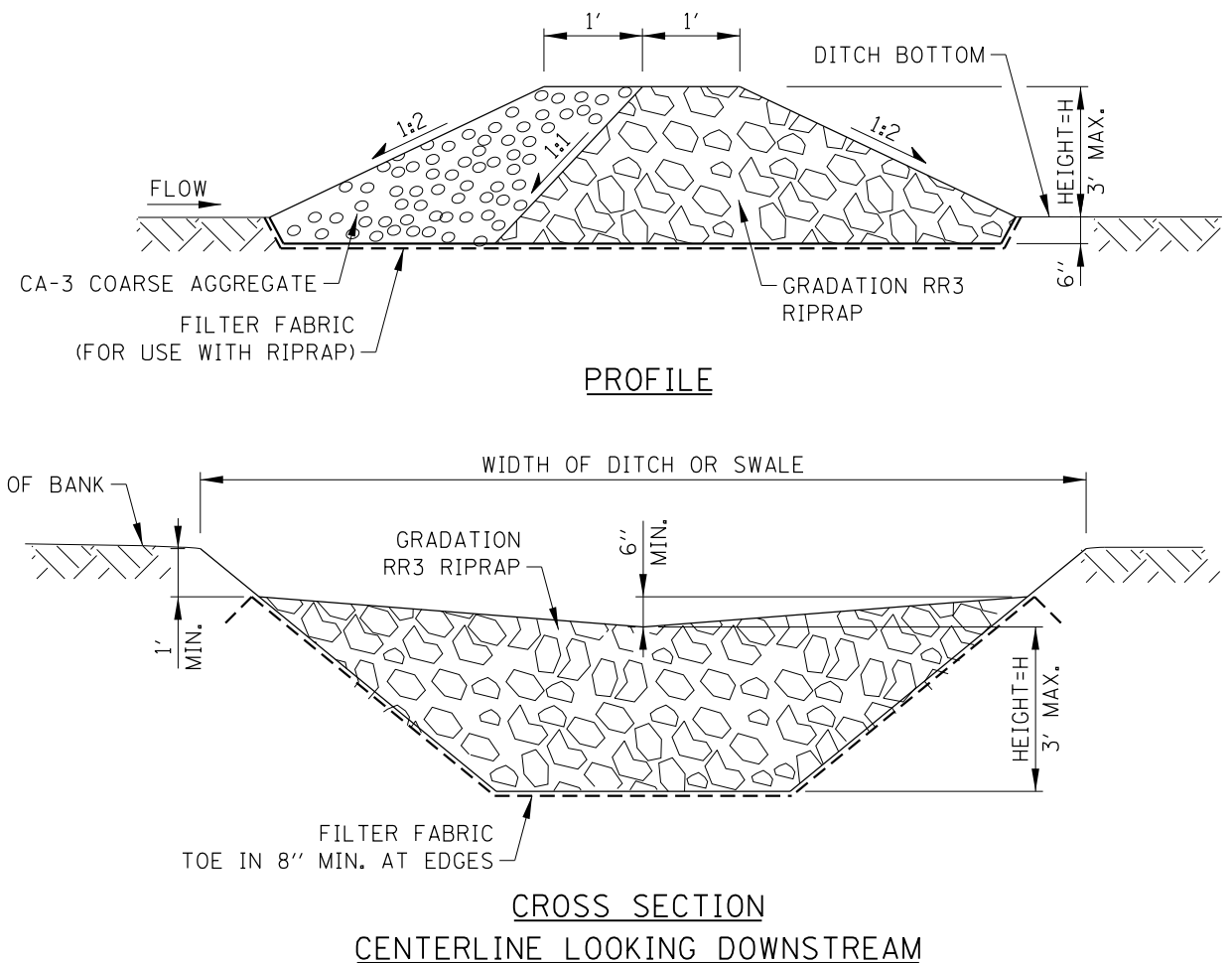
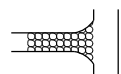

NOTES:

1. FOR LOCATIONS AND HEIGHTS OF ROCK CHECK DAMS REFER TO CONSTRUCTION DRAWINGS.
2. TEMPORARY ROCK CHECK DAMS SHALL BE REPLACED WHEN THEY CEASE TO FUNCTION AS INTENDED DUE TO WASHOUT OR CONSTRUCTION TRAFFIC DAMAGE.
3. SEDIMENT SHALL BE REMOVED WHEN IT REACHES 50% OF DAM HEIGHT. THIS PRACTICE IS NOT A SUBSTITUTE FOR MAJOR PERIMETER TRAPPING SUCH AS A TEMPORARY SEDIMENT TRAP OR BASIN.
4. SPACING BETWEEN DAMS SHALL BE SUCH THAT THE TOE OF THE UPSTREAM DAM IS AT THE SAME ELEVATION AS TOP OF RIPRAP AT THE CENTER OF THE DOWNSTREAM DAM.
5. WHEN A TEMPORARY ROCK CHECK DAM IS IN THE CLEAR ZONE, IT MUST BE MADE TRAVERSABLE TO AN ERRANT VEHICLE. THE MAXIMUM UNSHIELDED TRANSVERSE SLOPE ALLOWED TO FACE TRAFFIC SHALL BE 1:10 (V:H) AND THE MAXIMUM TRANSVERSE FACING AWAY FROM TRAFFIC SHALL BE 1:4 (V:H). AN UNSHIELDED TEMPORARY ROCK CHECK DAM SHALL HAVE AN ADDITIONAL LAYER OF CA-3 COURSE AGGREGATE (6" MIN.) PLACED ON THE DOWNSTREAM SIDE OF THE ROCK CHECK DAM. THE FILTER FABRIC SHALL BE PLACED ALONG THE ENTIRE BASE OF THE TEMPORARY ROCK CHECK DAM.

TEMPORARY ROCK CHECK DAM
STANDARD SYMBOL



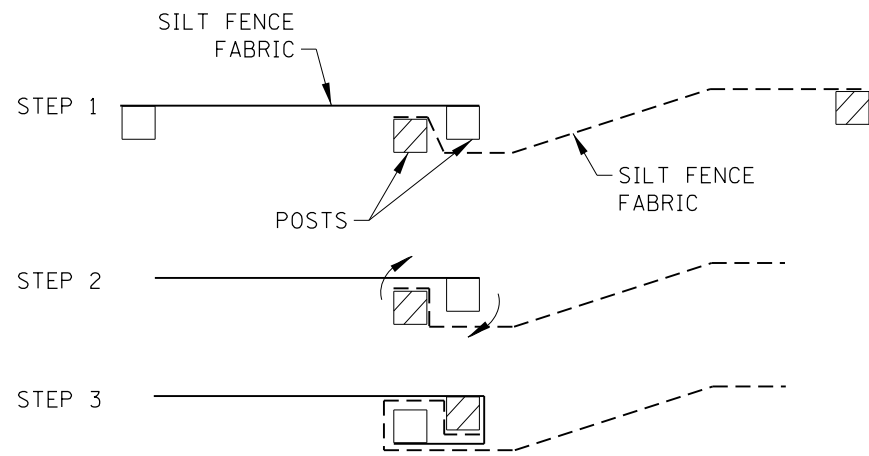

NOTES:

1. PLACE THE END POST OF THE SECOND FENCE INSIDE THE END POST OF THE FIRST FENCE.
2. ROTATE BOTH POSTS AT LEAST 180 DEGREES IN A CLOCKWISE DIRECTION TO CREATE A TIGHT SEAL WITH THE FABRIC MATERIAL.
3. DRIVE BOTH POSTS A MINIMUM OF 24" INTO THE GROUND.

ATTACHING TWO SILT FENCES

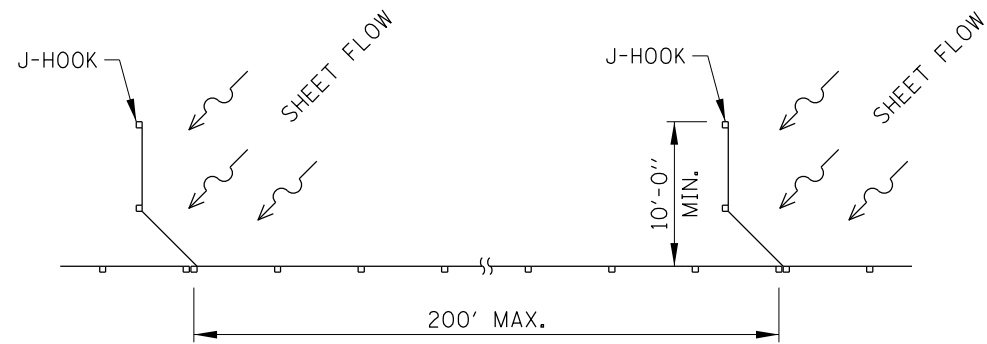

SILT FILTER J-HOOK PLACEMENT

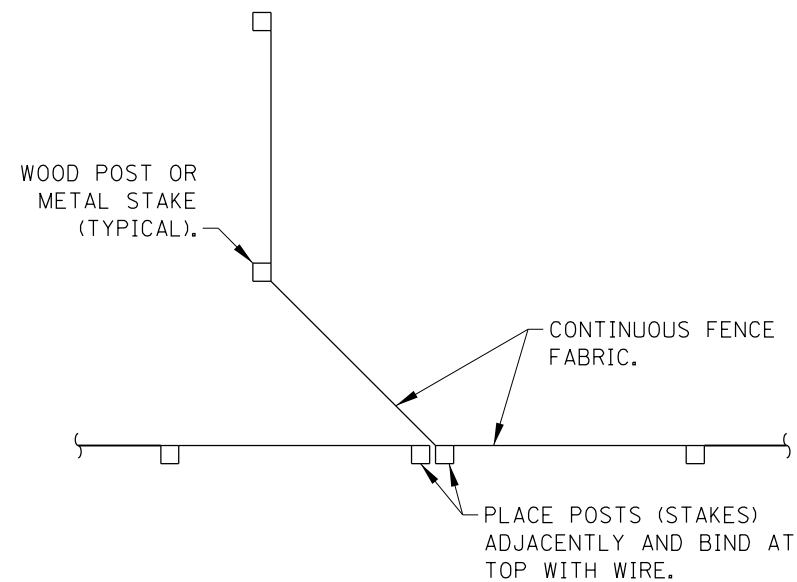

J-HOOK

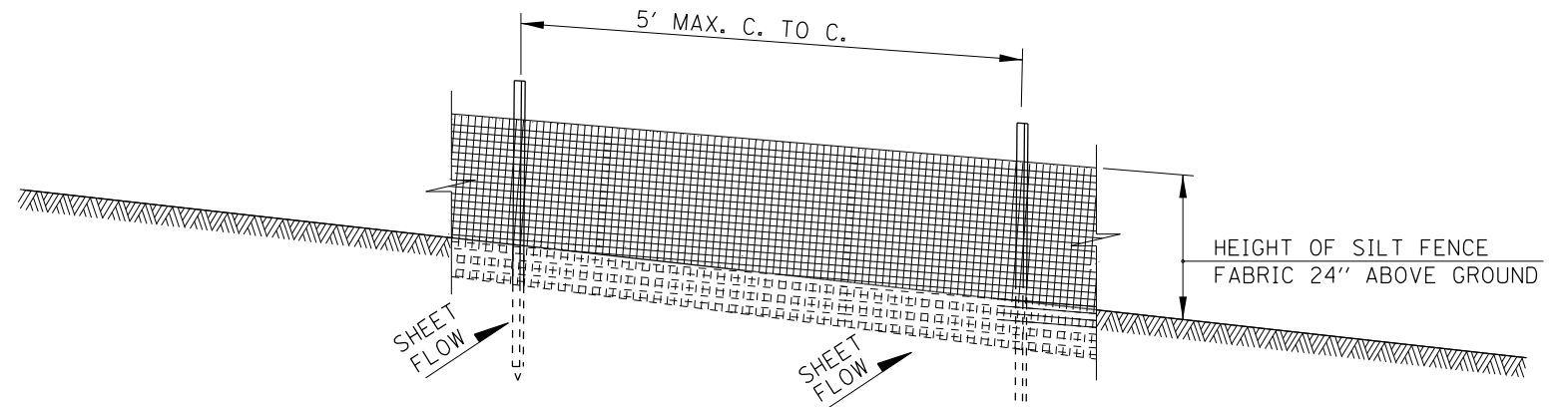

PERSPECTIVE VIEW

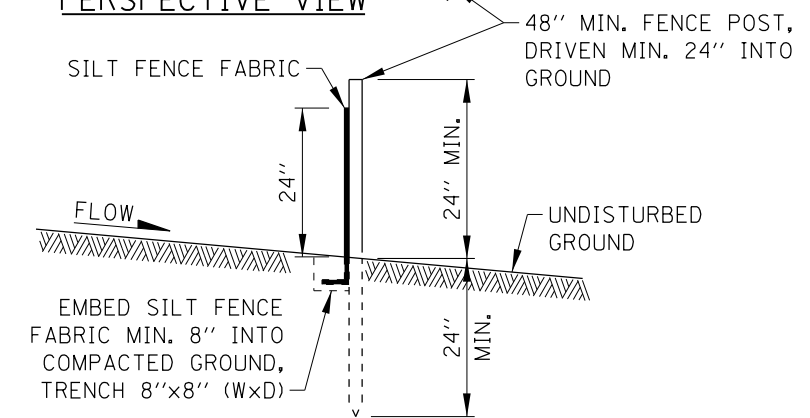

SECTION

NOTES:

1. SILT FENCE FABRIC TO BE FASTENED SECURELY TO FENCE POSTS.
2. WHEN TWO SECTIONS OF SILT FENCE FABRIC ADJOIN EACH OTHER THEY SHALL BE SECURELY FASTENED PER THE DETAIL ATTACHING TWO SILT FENCES.
3. MAINTENANCE SHALL BE PERFORMED AS NEEDED. SILT BUILD UP AGAINST FENCE SHALL BE REMOVED WHEN "BULGES" DEVELOP IN THE SILT FENCE, OR WHEN SILT REACHES 50% OF FENCE HEIGHT.
4. FENCE POSTS: 2"x2" (NOMINAL) HARDWOOD OR SCHEDULE 40 METAL PIPE OR 1.33 LB/FT MIN. STANDARD T OR U SECTION STEEL POSTS.
5. THIS DEVICE IS TO CONTROL SHEET FLOW ONLY. DO NOT USE FOR CONCENTRATED FLOWS, DRAINAGE CHANNELS, ABOVE OR BELOW DRAINAGE PIPES.

SILT FENCE (SF)
STANDARD SYMBOL

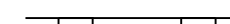

NOTES:

1. FENCING SHALL BE 36" IN HEIGHT AND CONSTRUCTED IN ACCORDANCE WITH ILLINOIS TOLLWAY STANDARD DRAWING D1, RIGHT-OF-WAY FENCE, TYPE 1. THE SPECIFICATION FOR A 6' FENCE SHALL BE USED, SUBSTITUTING 36" FABRIC AND 6' LENGTH POSTS.
2. CHAIN LINK FENCE SHALL BE FASTENED SECURELY TO THE FENCE POSTS WITH WIRE TIES. THE LOWER TENSION WIRE, BRACE AND TRUSS RODS, DRIVE ANCHORS AND POST CAPS ARE NOT REQUIRED. PULL POSTS, CORNER POSTS, HORIZONTAL BRACING AND TIE RODS ARE NOT REQUIRED.
3. SILT FENCE FABRIC SHALL BE FASTENED SECURELY TO THE CHAIN LINK FENCE WITH TIES SPACED EVERY 24" AT THE TOP AND MID SECTION.
4. WHEN TWO SECTIONS OF SILT FENCE FABRIC ADJOIN EACH OTHER, THEY SHALL BE OVERLAPPED 2' HORIZONTALLY.
5. MAINTENANCE SHALL BE PERFORMED AS NEEDED. SILT BUILD-UP AGAINST FENCE SHALL BE REMOVED WHEN SILT REACHES 50% OF FENCE HEIGHT.
6. SUPER SILT FENCE IS TO BE USED TO PROTECT ENVIRONMENTALLY SENSITIVE AREAS AND CONTROL SEDIMENT RUNOFF FROM CONSTRUCTION SITES WHEN ADDITIONAL REINFORCEMENT IS REQUIRED DUE TO SLOPE OF SITE OR VOLUME OF STORM WATER RUNOFF.

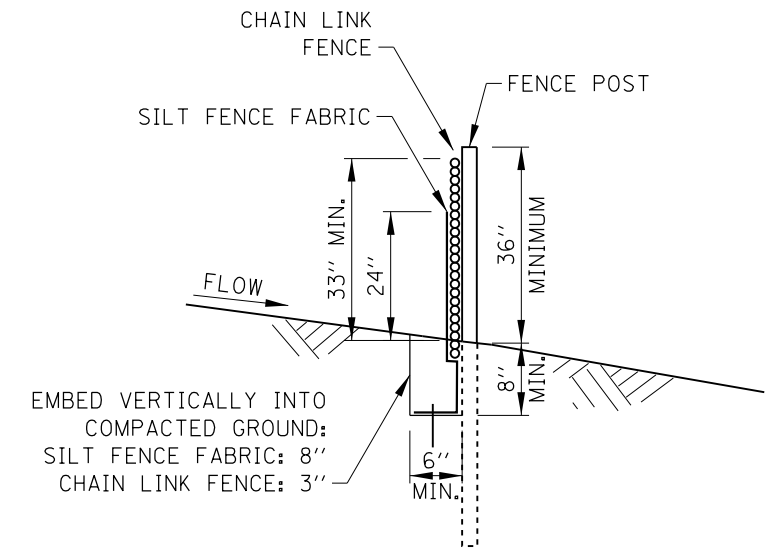
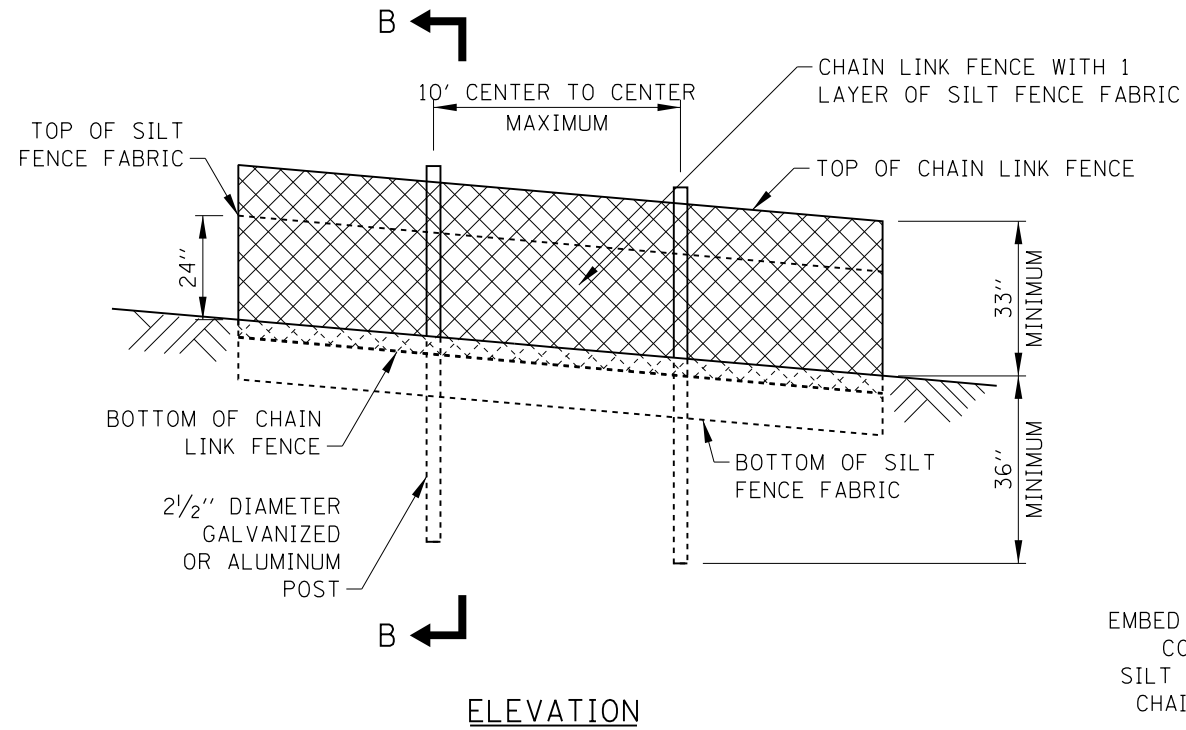

SUPER SILT FENCE (SSF)
STANDARD SYMBOL

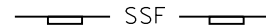

NOTES:

1. A MINIMUM 50' WIDE VEGETATED BUFFER STRIP SHALL BE PRESERVED AND/OR RE-ESTABLISHED WHERE POSSIBLE ALONG EXISTING CHANNELS.
 - a. FOR ANY WATERS OF THE U.S. DETERMINED TO BE A HIGH-QUALITY AQUATIC RESOURCE, THE BUFFER MUST BE A MINIMUM OF 100'.
 - b. FOR ANY WATERS OF THE U.S. THAT DO NOT QUALIFY AS WETLAND (FOR EXAMPLE LAKES, RIVERS, PONDS, ETC.), THE BUFFER MUST BE A MINIMUM OF 50' FROM THE ORDINARY HIGH WATER MARK (OHWM).
 - c. FOR ANY JURISDICTIONAL WETLAND, THE BUFFER MUST BE A MINIMUM OF 50'.
2. THE 5' GAPS IN THE SILT FENCE AND THE 12" DIAMETER TEMPORARY DITCH CHECKS ARE TO ALLOW FLOODWATER FLOW INTO THE CREEK FROM THE SITE WITHOUT DAMAGE TO THE SILT FENCE.
3. MAINTENANCE SHALL BE PERFORMED AS NEEDED AND SILT SHALL BE REMOVED WHEN IT REACHES 50% OF ROLL HEIGHT. WHEN THE ROLLED EXCELSIOR LOG IS REDUCED TO 50% OF ROLL HEIGHT IT SHALL BE REPLACED.

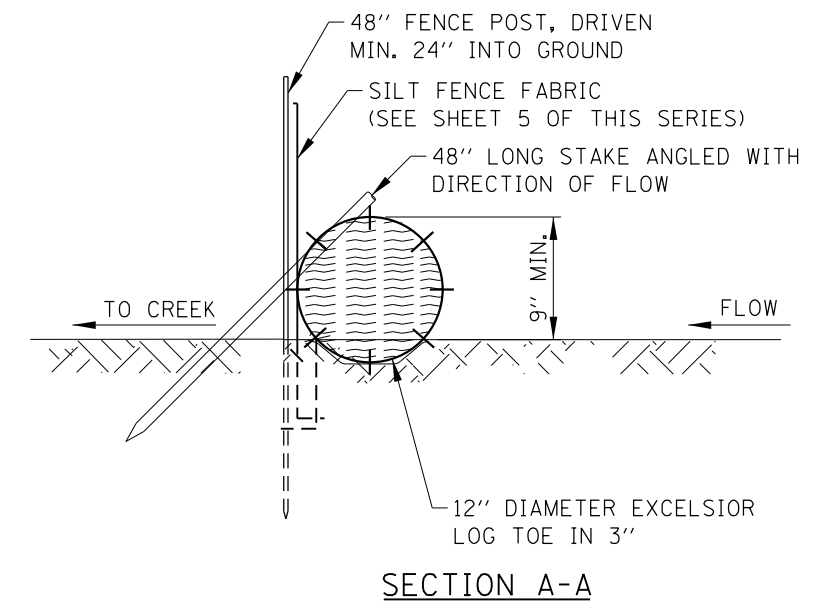
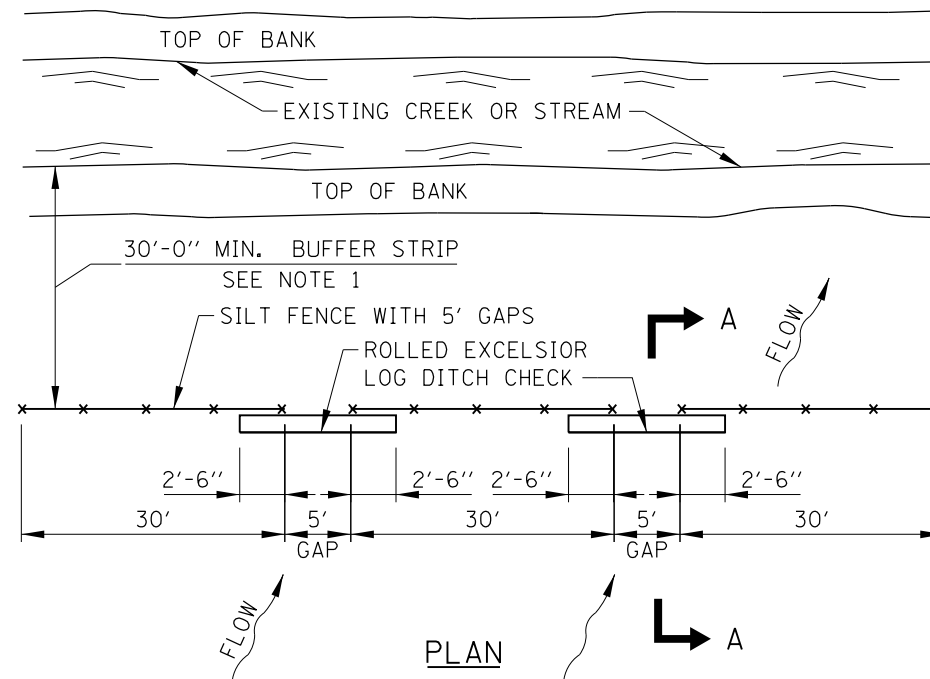

CREEK BUFFER STRIP AND SILT FENCE

Paul Kovacs
APPROVED... CHIEF ENGINEERING OFFICER DATE 2-7-2012



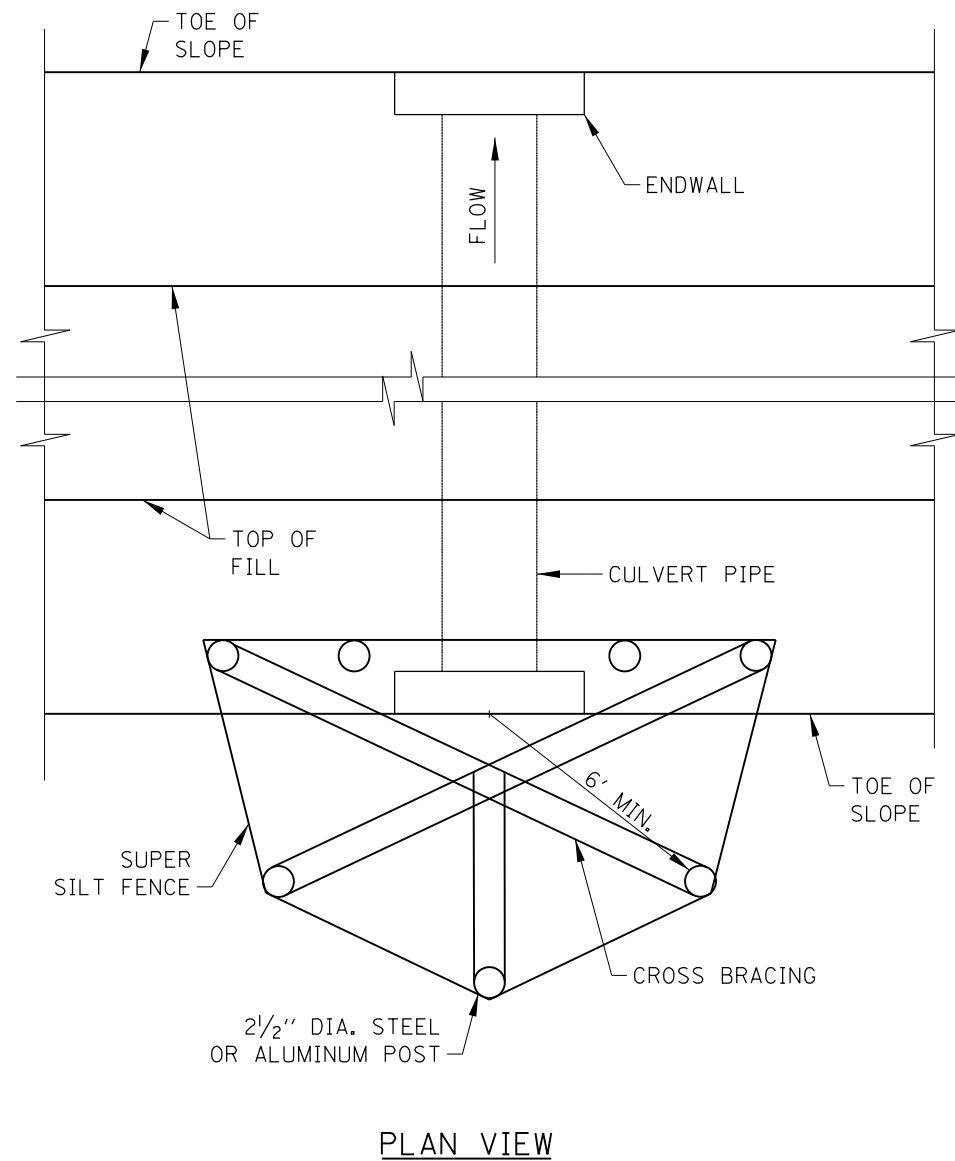

PLAN VIEW

NOTES:

1. CONSTRUCT SUPER SILT FENCE PER SHEET 6 IN THIS SERIES, EXCEPT THE MAXIMUM POST SPACING SHALL BE 3 FEET AND THE TOPS OF POSTS SHALL BE CROSSED BRACED.
2. MAINTENANCE SHALL BE PERFORMED AS NEEDED. SEDIMENT SHALL BE REMOVED WHEN IT REACHES 50% OF THE FENCE HEIGHT.
3. THE CULVERT INLET PROTECTION AND SEDIMENT SHALL BE REMOVED WHEN CONSTRUCTION IS COMPLETE.
4. THE CULVERT INLET PROTECTION - FENCE TO BE MEASURED AND PAID FOR AS SUPER SILT FENCE.

CULVERT INLET PROTECTION - FENCE

STANDARD SYMBOL

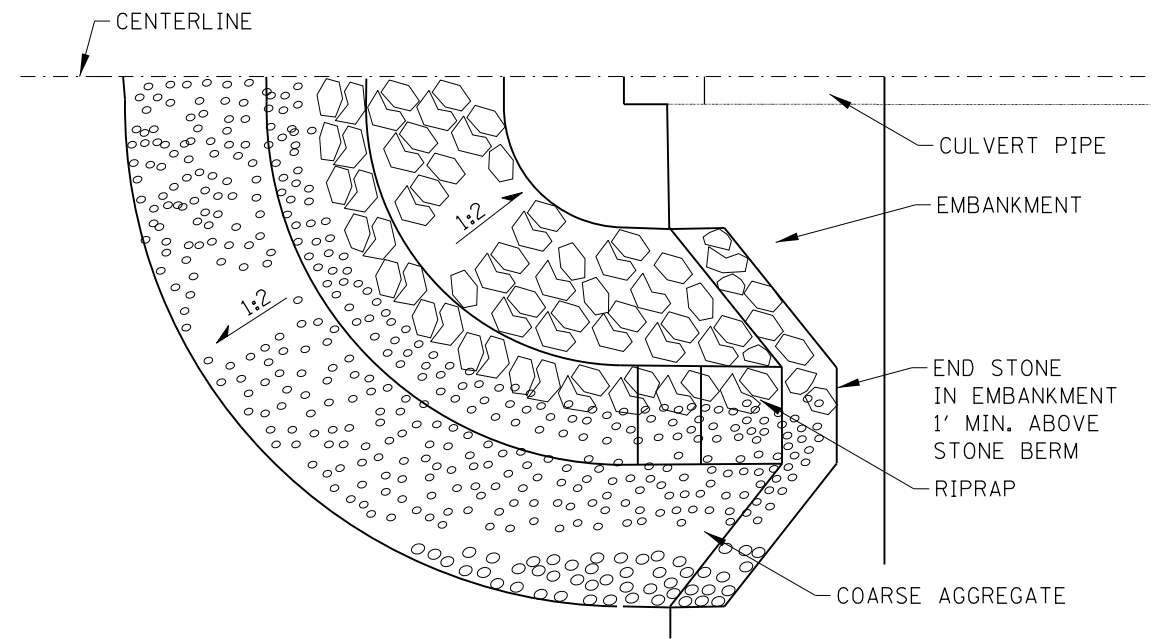
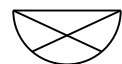

HALF PLAN VIEW

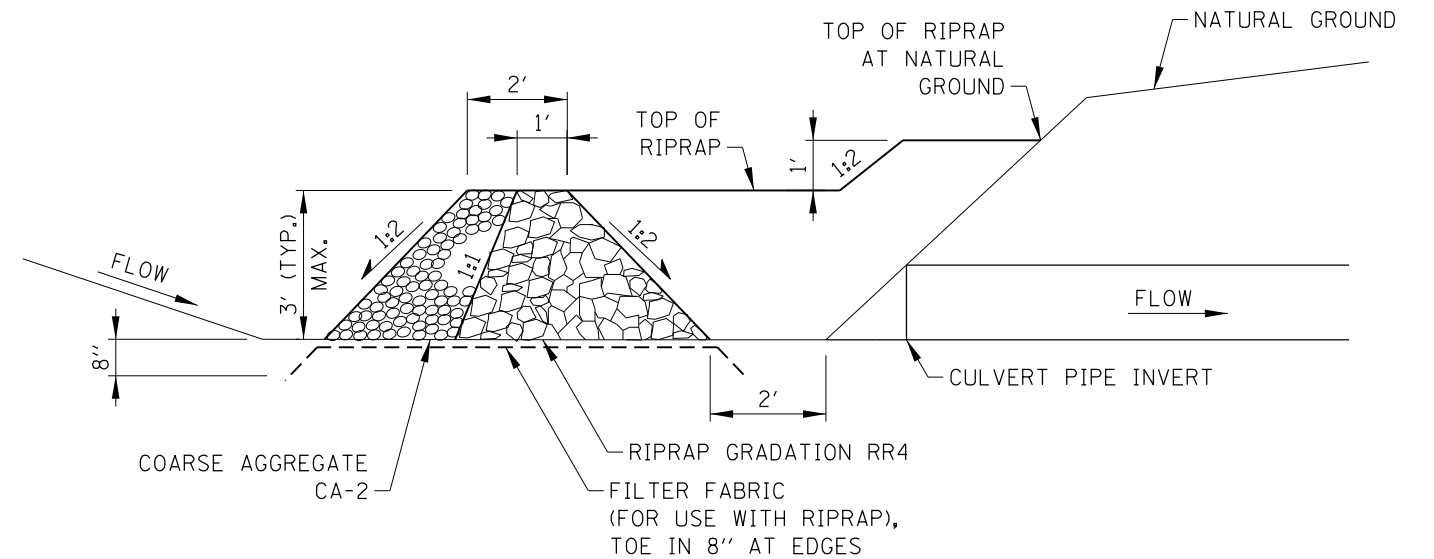

CENTERLINE CROSS SECTION

NOTES:

1. MAINTENANCE SHALL BE PERFORMED AS NEEDED. SEDIMENT SHALL BE REMOVED WHEN IT REACHES 50% OF THE STONE HEIGHT.
2. THE CULVERT INLET PROTECTION AND SEDIMENT SHALL BE REMOVED WHEN CONSTRUCTION IS COMPLETE.
3. THE CULVERT INLET PROTECTION - STONE TO BE MEASURED AND PAID FOR AS TEMPORARY RIPRAP.

CULVERT INLET PROTECTION - STONE

STANDARD SYMBOL



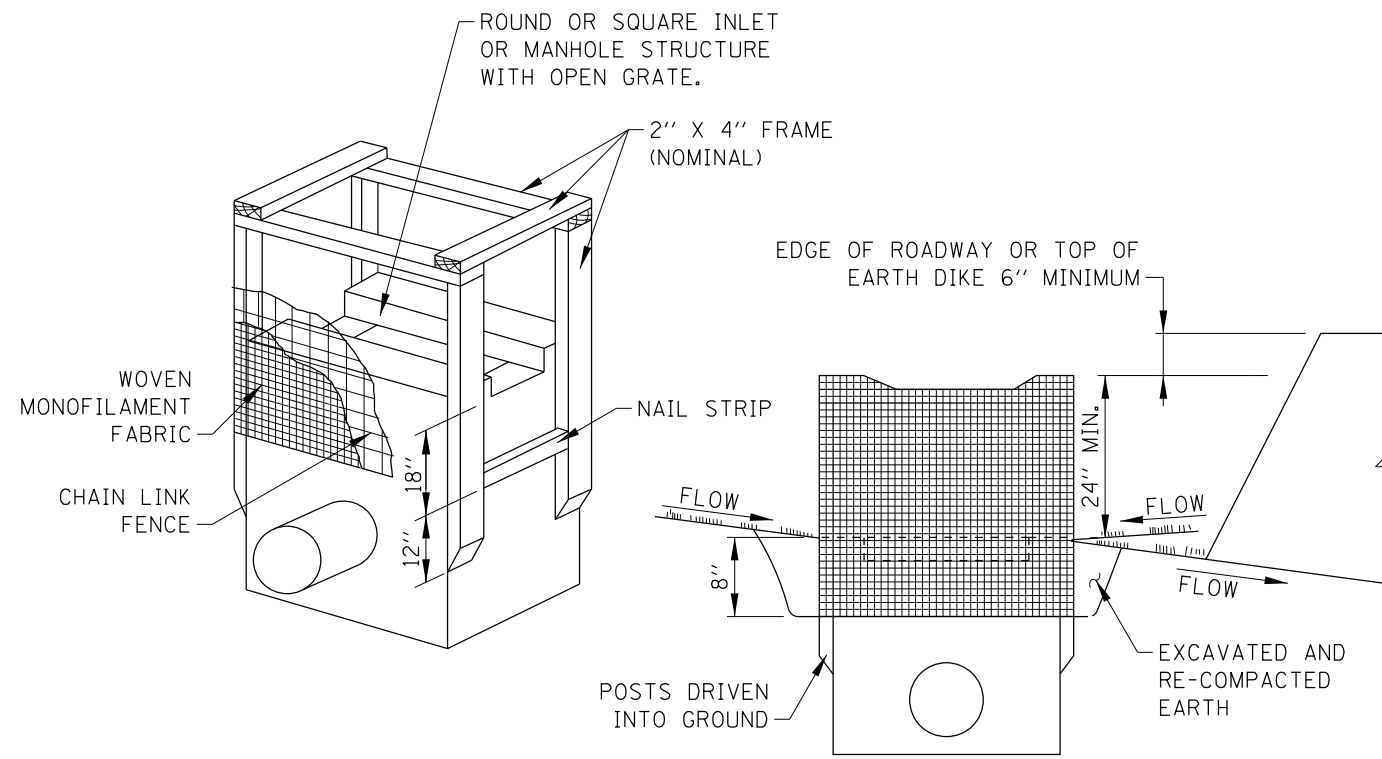

WOOD FRAME

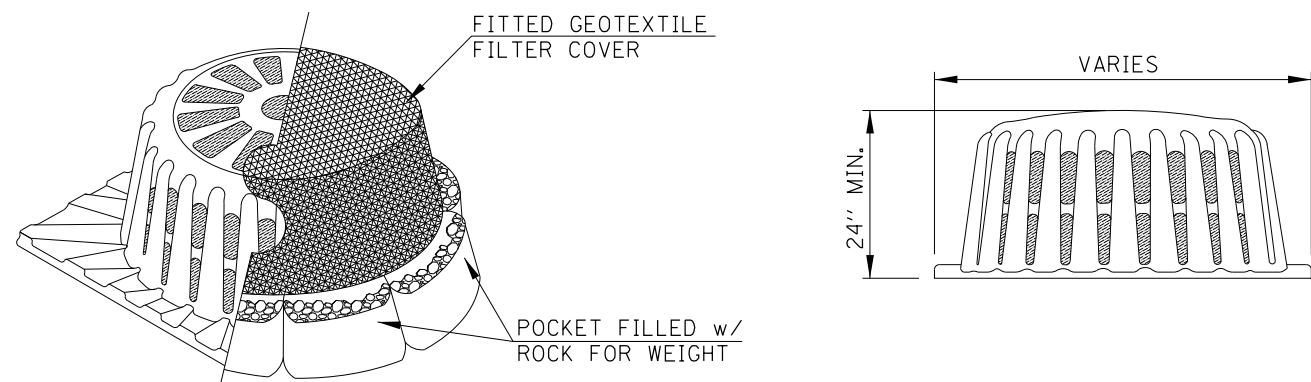

POLYETHYLENE FRAME

NOTES:

1. WOODEN FRAME IS TO BE CONSTRUCTED OF 2"x4" CONSTRUCTION GRADE LUMBER. AT THE CONTRACTOR'S OPTION, THE WOOD FRAME CAN BE SUBSTITUTED USING 2 1/2" GALVANIZED OR ALUMINUM POSTS INSTALLED AS SPECIFIED FOR SUPER SILT FENCE.
2. MAINTENANCE SHALL BE PERFORMED AS NEEDED AND SILT REMOVED WHEN IT REACHES 50% OF FENCE HEIGHT.
3. TO BE USED TO PROTECT EXISTING AND NEW INLETS, CATCH BASINS AND MANHOLES WITH OPEN LIDS IN NON-PAVED AREAS.

RECTANGULAR INLET PROTECTION
STANDARD SYMBOL

Paul Kovacs
APPROVED... CHIEF ENGINEERING OFFICER DATE 2-7-2012

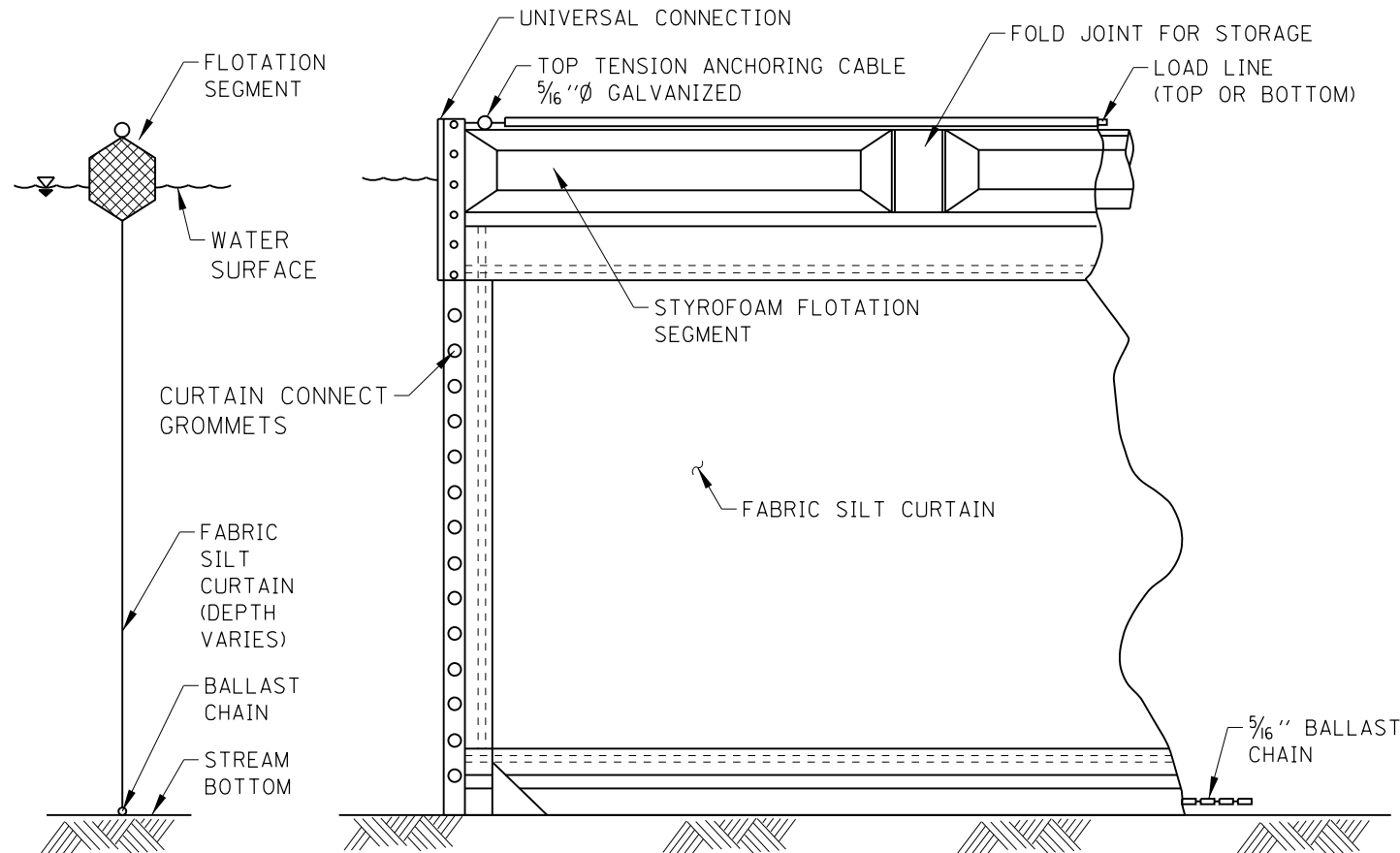

SECTION

ELEVATION

NOTES:

1. FLOTATION BOOM FOR USE IN MOVING WATER SHALL BE ANCHORED TO PREVENT DRIFT SHOREWARD OR DOWNSTREAM. ANCHORAGES SHALL BE INSTALLED ON BOTH SHORE AND STREAM SIDE. BOOMS ARE NOT TO BE INSTALLED ACROSS FLOWING BODY OF WATER.
2. SHORE ANCHORS SHALL CONSIST OF A POST WITH DEADMAN OR APPROVED EQUAL. STREAM ANCHORS SHALL BE OF SUFFICIENT SIZE TO STABILIZE THE BARRIER WITH NUMBER AND SPACING DEPENDENT ON WATERWAY VELOCITIES.
3. FABRIC SECTIONS SHALL BE CONNECTED END TO END WITH MINIMUM 5/8" DIAMETER POLYPROPYLENE ROPE.
4. DESIGN OF BOOM AND ANCHORAGE SHALL BE IN ACCORDANCE WITH MANUFACTURER'S RECOMMENDATIONS. BOTTOM OF BOOM SHALL REACH BOTTOM OF WATERWAY USING ONE VERTICAL SECTION AS REQUIRED.
5. MAINTENANCE SHALL BE PERFORMED AS NEEDED. CONTRACTOR SHALL REMOVE THE BOOM AT COMPLETION OF WORK IN A MANNER THAT WILL PREVENT SILTATION OF THE WATERWAY.
6. CONSTRUCTION DEBRIS/MATERIALS SHALL BE REMOVED IMMEDIATELY TO PREVENT DAMAGE TO THE CURTAIN AND ENTRY INTO THE WATERWAY.
7. FLOTATION BOOMS TO BE USED TO CONTROL TURBIDITY WHEN WORKING IN WATERWAYS.

FLOTATION BOOM
STANDARD SYMBOL
—FB— FB—



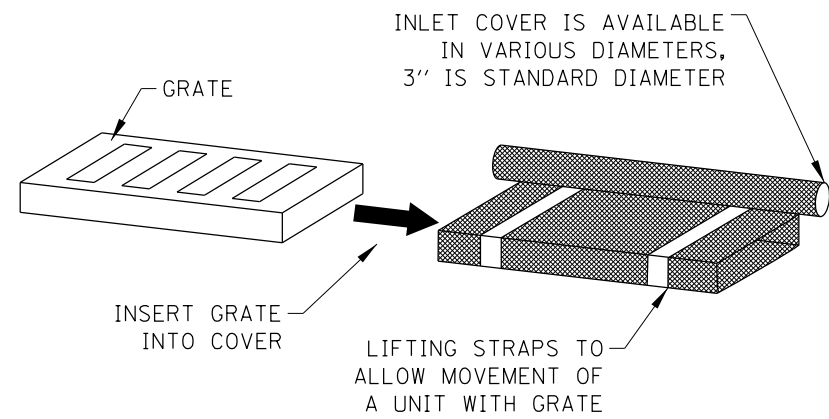

GRATE AND COVER DETAIL

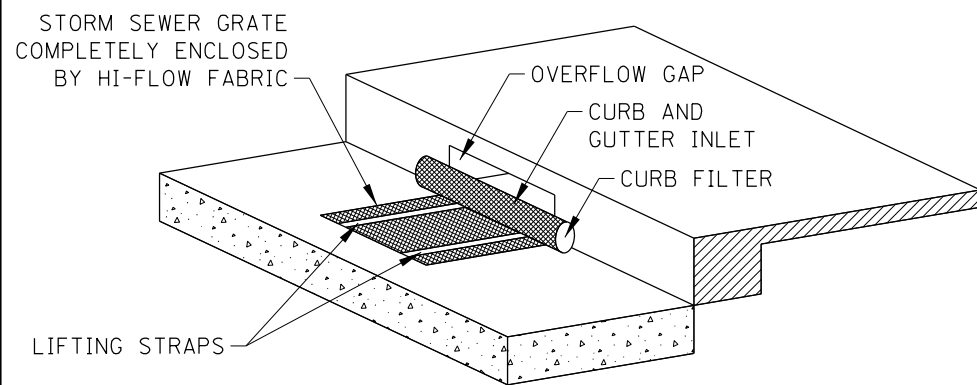

NOTES:

1. COVER TYPE INLET PROTECTION SHALL CONSIST OF FABRIC SLEEVE AND, IF NECESSARY, CURB FILTER.
2. DEVICE SHALL BE EQUIPPED WITH AN OVERFLOW GAP SO DRAINAGE TO INLET IS NOT COMPLETELY BLOCKED IF DEVICE IS FULL OF SILT.
3. MAINTENANCE SHALL BE PERFORMED AS NEEDED. REMOVE SILT FROM FABRIC INSERT WHEN SEDIMENT ACCUMULATES, THE FILTER BECOMES CLOGGED, AND/OR PERFORMANCE IS COMPROMISED. WHEN THERE IS EVIDENCE OF SEDIMENT ACCUMULATION ADJACENT THE THE INLET PROTECTION MEASURE, THE DEPOSITED SEDIMENT SHALL BE REMOVED BY THE END OF THE SAME BUSINESS DAY IN WHICH IT IS FOUND OR BY THE END OF THE FOLLOWING BUSINESS DAY IF REMOVAL THE SAME BUSINESS DAY IS NOT FEASIBLE.
4. STORM SEWER GRATE SHALL BE COMPLETELY ENCLOSED BY FABRIC.
5. GRATE AND FILTER ARE TO BE SET SECURELY BACK IN FRAME.

FILTER FABRIC INLET PROTECTION - COVER TYPE

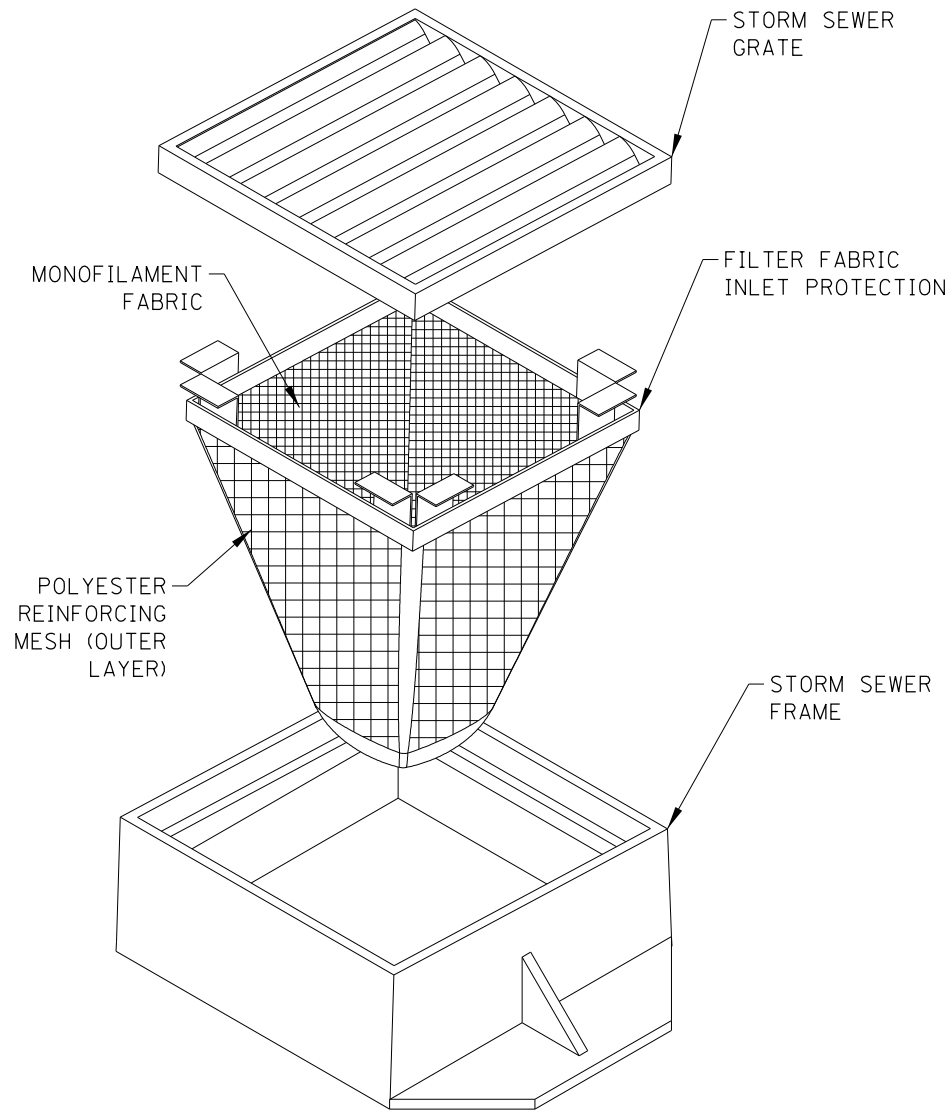

NOTES:

1. MONOFILAMENT FABRIC INLET PROTECTION SHALL CONSIST OF INLET BASKET, FRAME AND FABRIC INSERT.
2. DEVICE SHALL BE EQUIPPED WITH AN OVERFLOW FEATURE SO DRAINAGE TO INLET IS NOT COMPLETELY BLOCKED IF DEVICE IS FULL OF SILT.
3. INLET BASKET IS AVAILABLE TO FIT ROUND, RECTANGULAR, BEEHIVE OR CURB INLET CASTINGS.
4. MAINTENANCE SHALL BE PERFORMED AS NEEDED. REMOVE SILT FROM FABRIC INSERT WHEN 50% OF CAPACITY IS REACHED. REMOVE SILT FROM INTERIOR AND EXTERIOR OF INLET COVER WHEN 50% OF COVER HEIGHT IS REACHED. WHEN THERE IS EVIDENCE OF SEDIMENT ACCUMULATION ADJACENT THE THE INLET PROTECTION MEASURE, THE DEPOSITED SEDIMENT SHALL BE REMOVED BY THE END OF THE SAME BUSINESS DAY IN WHICH IT IS FOUND OR BY THE END OF THE FOLLOWING BUSINESS DAY IF REMOVAL THE SAME BUSINESS DAY IS NOT FEASIBLE.

FILTER FABRIC INLET PROTECTION - BASKET TYPE

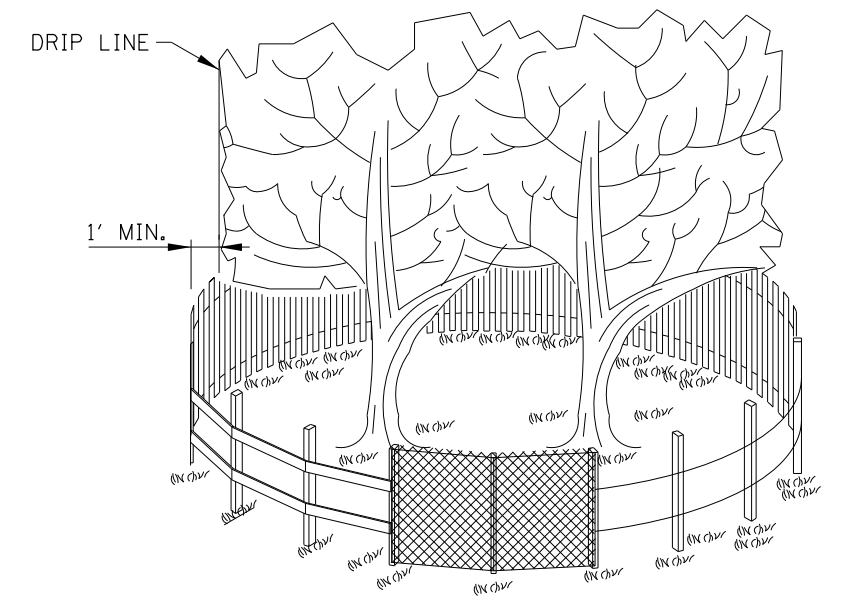

SIDE VIEW

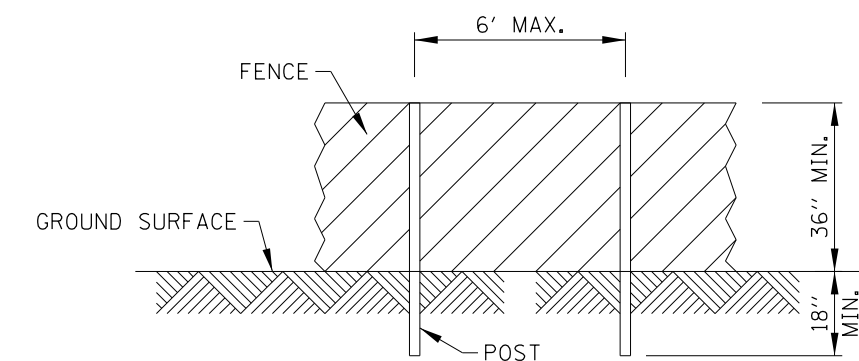

POST AND FENCE DETAIL

NOTES:

1. THE FENCE SHALL BE LOCATED 1 FOOT MINIMUM OUTSIDE THE DRIP LINE OF THE TREE TO BE SAVED AND IN NO CASE CLOSER THAN 5 FEET TO THE TRUNK OF ANY TREE.
2. THE FENCE SHALL BE HIGH VISIBILITY PLASTIC OR WOOD LATH SNOW FENCE TO CLEARLY DELINEATE THE PROTECTION AREA.
3. USED TO PROTECT TREES FROM DISTURBANCE AND FROM EQUIPMENT TRAVELING OVER THE ROOT ZONE.

**TREE PROTECTION
STANDARD SYMBOL**



ATTACHMENT A

Spill Information Form

SPILL INFORMATION FORM

(page 1 of 2)

Requested Information	Response
<i>Date/Time of Report</i>	
<i>Name, address location & phone number of the facility</i>	
<i>Name, title, phone number of person reporting the spill, responsible party and contact person.</i>	
<i>Spill location within the facility and if outside-township, range and section (quarter section).</i>	
<i>Spill source and material spilled or released.</i>	
<i>Estimated volume or quantity of the spill.</i>	
<i>Complete description of containment and remedial efforts.</i>	

SPILL INFORMATION FORM

(page 2 of 2)

Requested Information	Response
<i>Media affected by spill (i.e. soil, water, groundwater), the extent of actual and potential pollution.</i>	
<i>A chronology of all occurred events including a complete description of circumstances causing the release or spill, actions taken and explanations.</i>	
<i>Was the release or spill of a listed hazardous waste and/or is it a characteristic hazardous waste?</i>	
<i>A description and estimate of any third party damages.</i>	
<i>Procedures, methods and precautions instituted to prevent a similar reoccurrence.</i>	
<i>Other information appropriate for the particular release.</i>	
<i>Other parties contacted.</i>	

(Copy form as necessary)