

PLAN

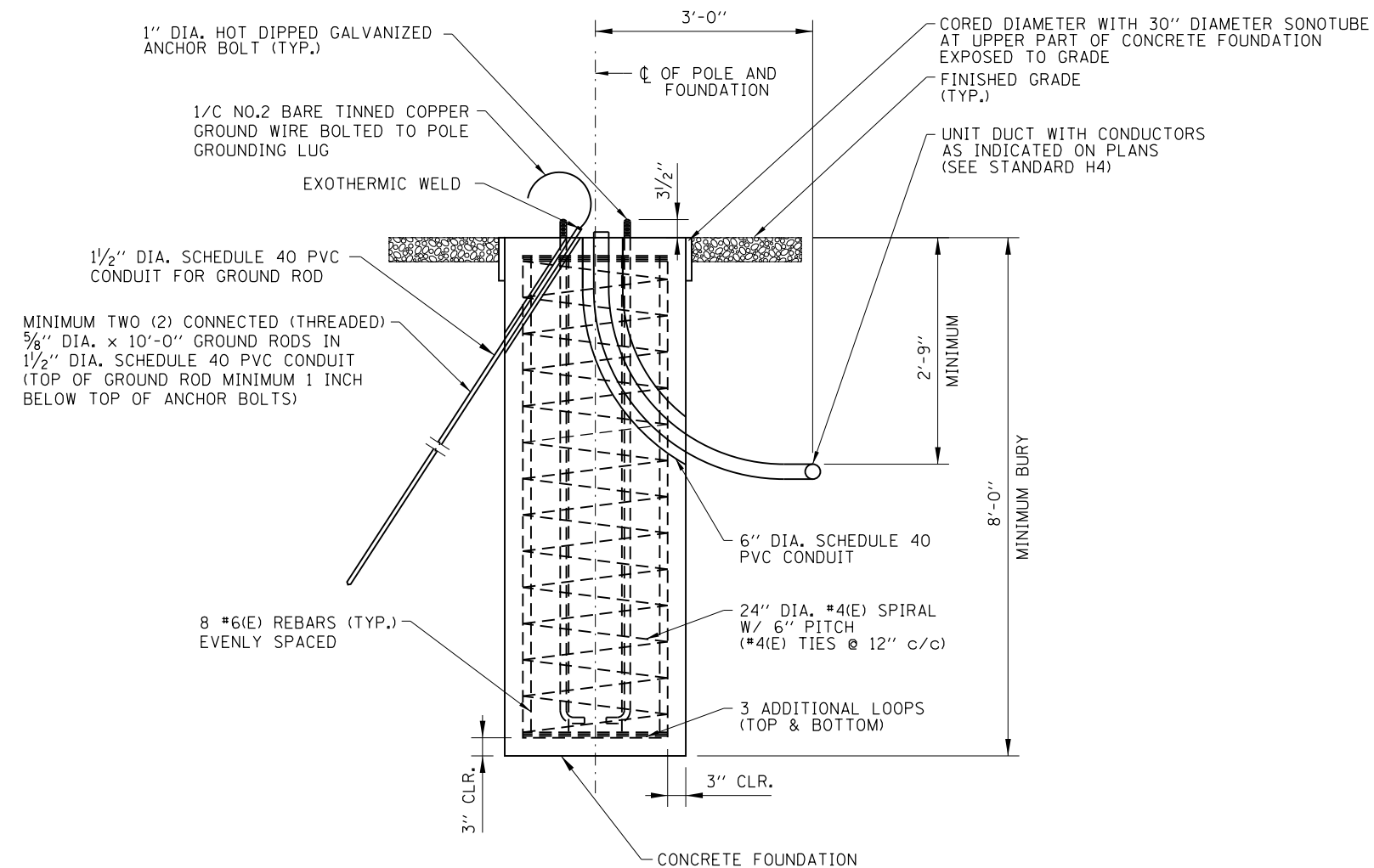

ELEVATION

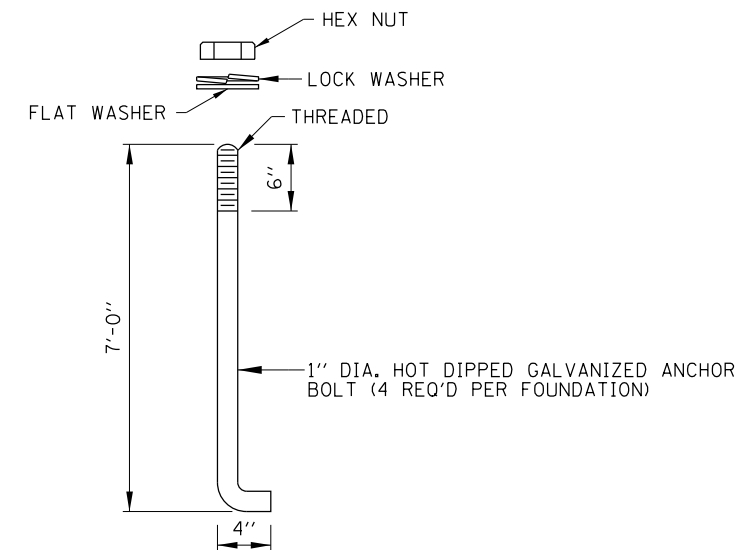

ANCHOR BOLT DETAIL

NOTES:

1. AT LOCATIONS NOT SHIELDED BY GUARDRAIL, THE LIGHT POLE FOUNDATION SHALL BE FLUSH WITH SURROUNDING GRADED ON ALL SIDES. THE SURROUNDING AREA SHALL BE A LEVEL GRADED AREA CONSTRUCTED OF AGGREGATE SHOULDERS WITH FILTER FABRIC, TYPE B, 4".
2. PROVIDE SEEDING, POTASIMUM FERTILIZER NUTRIENT, AND EROSION CONTROL BLANKET AS REQUIRED.
3. THE TOP OF FOUNDATION SHALL BE AT THE SAME ELEVATION AS THE ADJACENT TOP OF GUTTER OR WHEN ADJACENT TO AGGREGATE SHOULDER, AT THE SAME ELEVATION AS THE OUTSIDE EDGE OF THE AGGREGATE SHOULDER SLOPED A MAXIMUM 6% AWAY FROM THE PAVED SHOULDER.
4. ALL SLOPES ARE EXPRESSED AS UNITS OF VERTICAL DISPLACEMENT TO UNITS OF HORIZONTAL DISPLACEMENT (V:H).
5. ALL GROUND MOUNTED LIGHT POLES SHALL BE PROVIDED WITH AN ACCEPTED FHWA BREAKAWAY BASE OR DEVICE PER THE ILLINOIS TOLLWAY SUPPLEMENTAL SPECIFICATIONS SECTION 1070.
6. FOR DETAILS OF FUSE HOLDER, POLE BASE WIRING AND CONDUCTOR SPLICE SEE STANDARD H2.
7. ALL REINFORCEMENT BARS SHALL BE EPOXY COATED.
8. ALL EQUIPMENT SHALL BE GROUNDED AND BONDED IN ACCORDANCE WITH THE NATIONAL ELECTRICAL CODE AND THE NATIONAL ELECTRICAL SAFETY CODE.
9. FOR ALL MEDIAN BARRIER FOUNDATIONS, THE ANCHOR BOLTS SHALL BE CENTERED AROUND THE MEDIAN BARRIER WALL CENTERLINE.

LIGHT STANDARD FOUNDATION DETAILS - CONCRETE  
(GROUND MOUNTED UNITS)

APPROVED: *Paul Kovacs* DATE: 2-7-2012  
CHIEF ENGINEERING OFFICER

DATE	REVISIONS
3-31-2014	REVISED HELIX FOUNDATION, NEW DETAIL
3-11-2015	"A", AND GRADED AREA MOVED MEDIAN BARRIER MOUNTED FOUNDATION DETAILS.
3-31-2016	REVISED MEDIAN FOUNDATION ANCHOR BOLTS.
3-31-2017	ADDED HELIX FOUNDATION DEPTH INFORMATION.
3-01-2018	INCREASED POLE SETBACK.
3-01-2019	REVISED CONCRETE BARRIER DETAILS.
3-01-2019	REDUCED SETTING PLATE SIZE.
3-01-2020	ADDED SINGLE FACE BARRIER DETAIL.



LIGHT STANDARD FOUNDATION

STANDARD H1-09

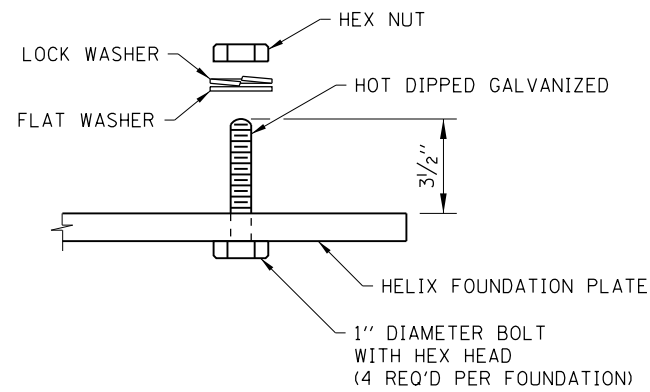

**BASE ATTACHMENT DETAIL**

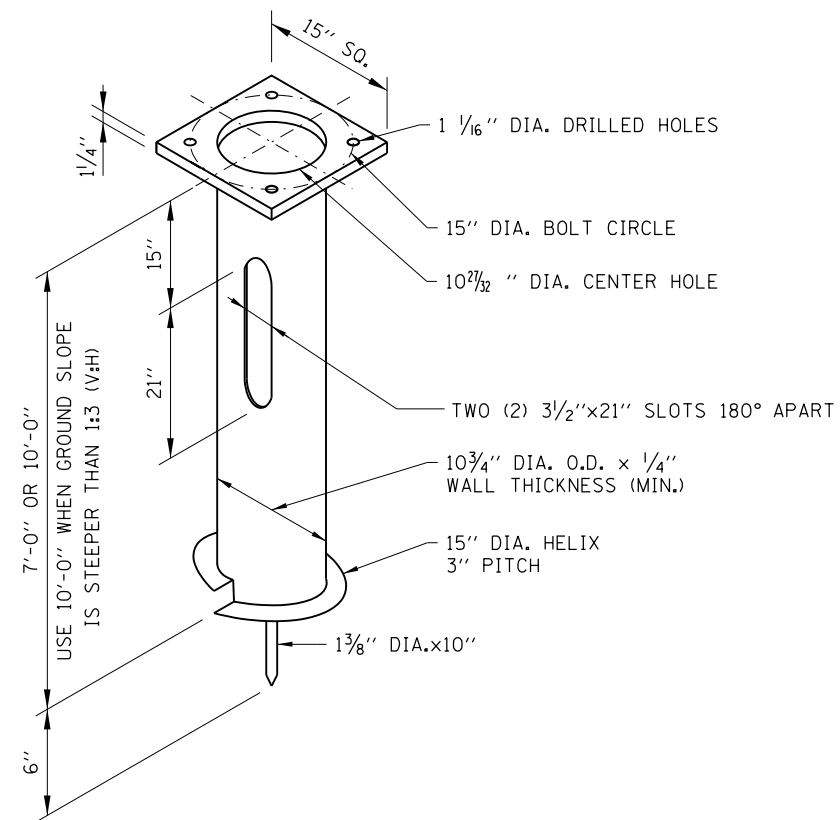

**ISOMETRIC**

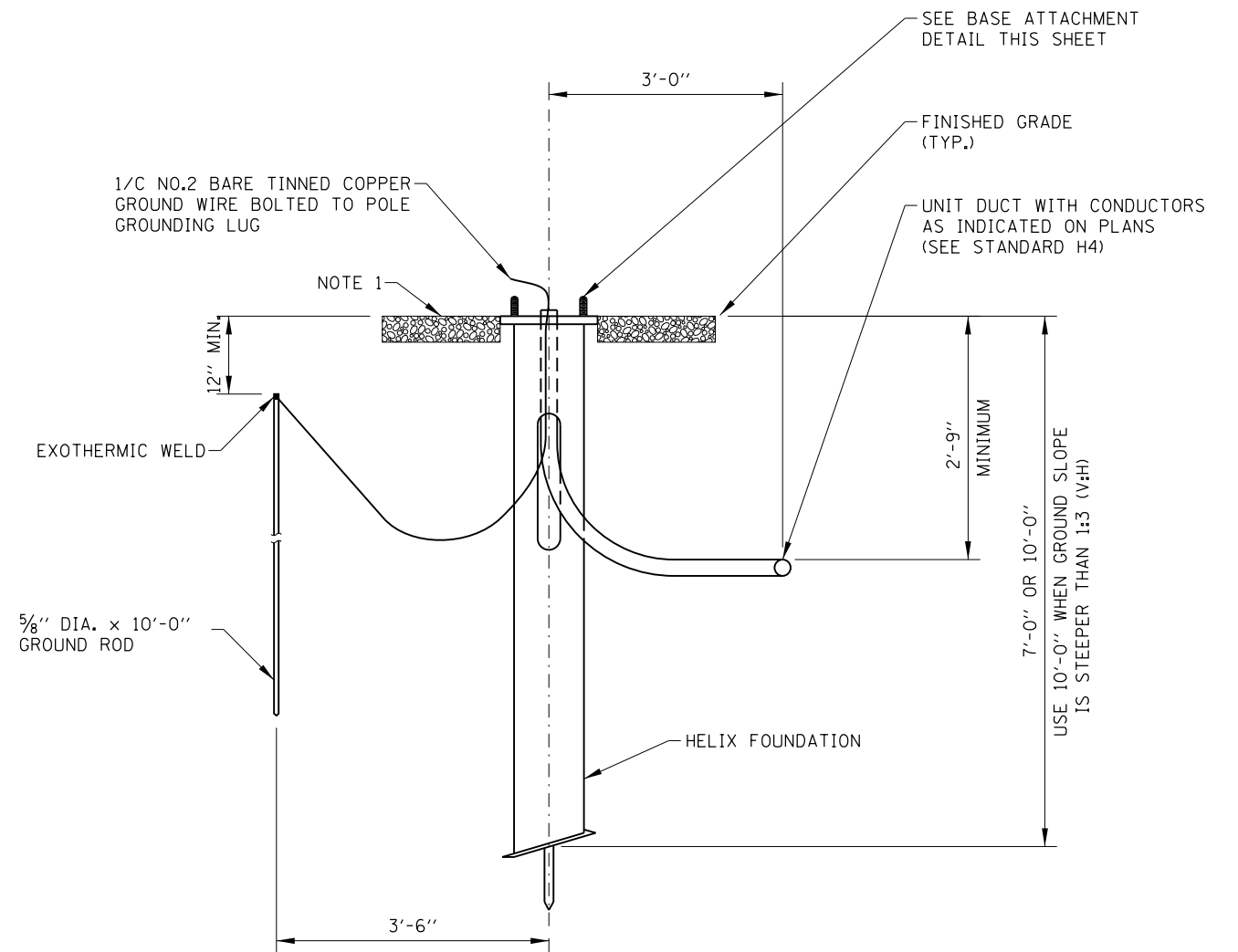

**ELEVATION**

APPROVED: *Paul Kovacs*  
CHIEF ENGINEERING OFFICER  
DATE: 2-7-2012

**LIGHT STANDARD FOUNDATION DETAILS - HELIX  
(GROUND MOUNTED UNITS)**

NOTES:  
SEE SHEET 1 OF THIS SERIES FOR NOTES.



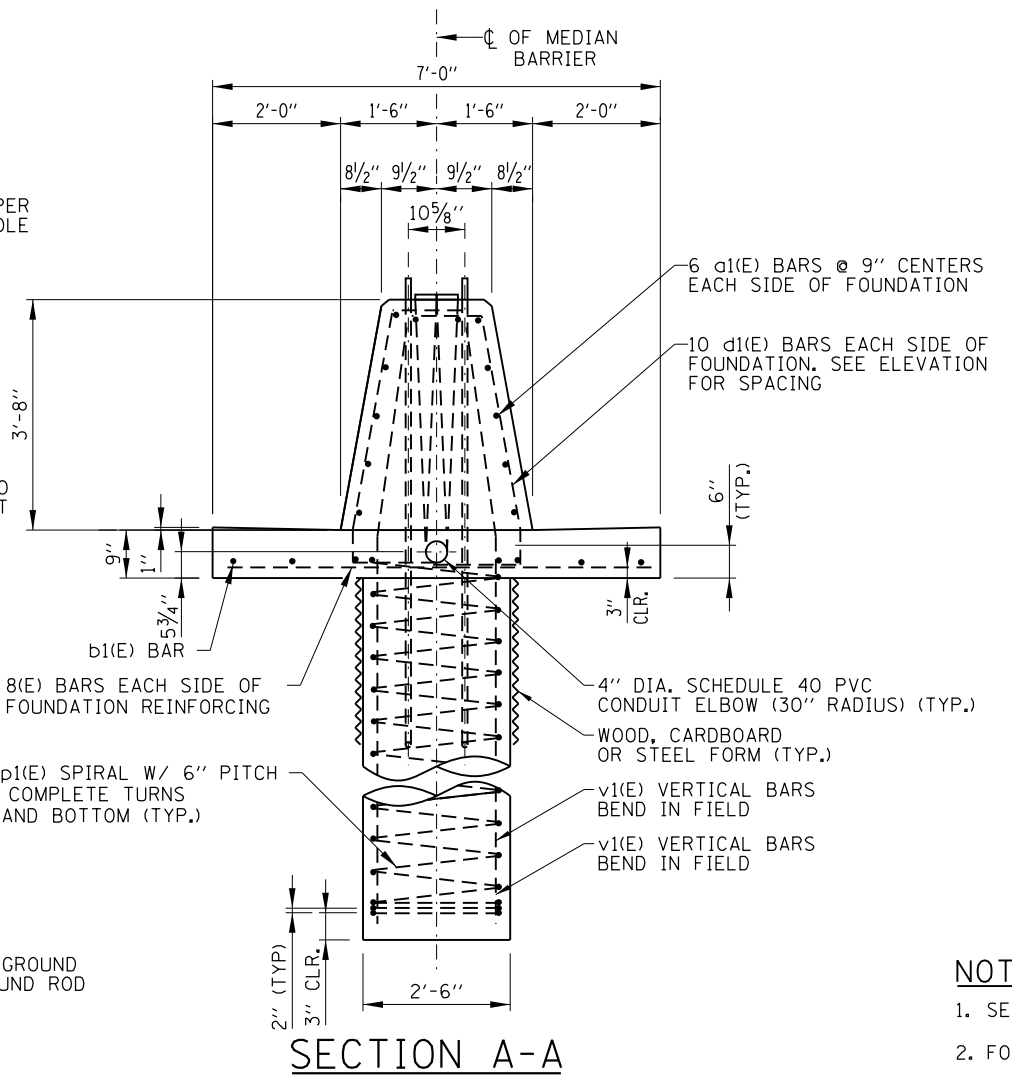
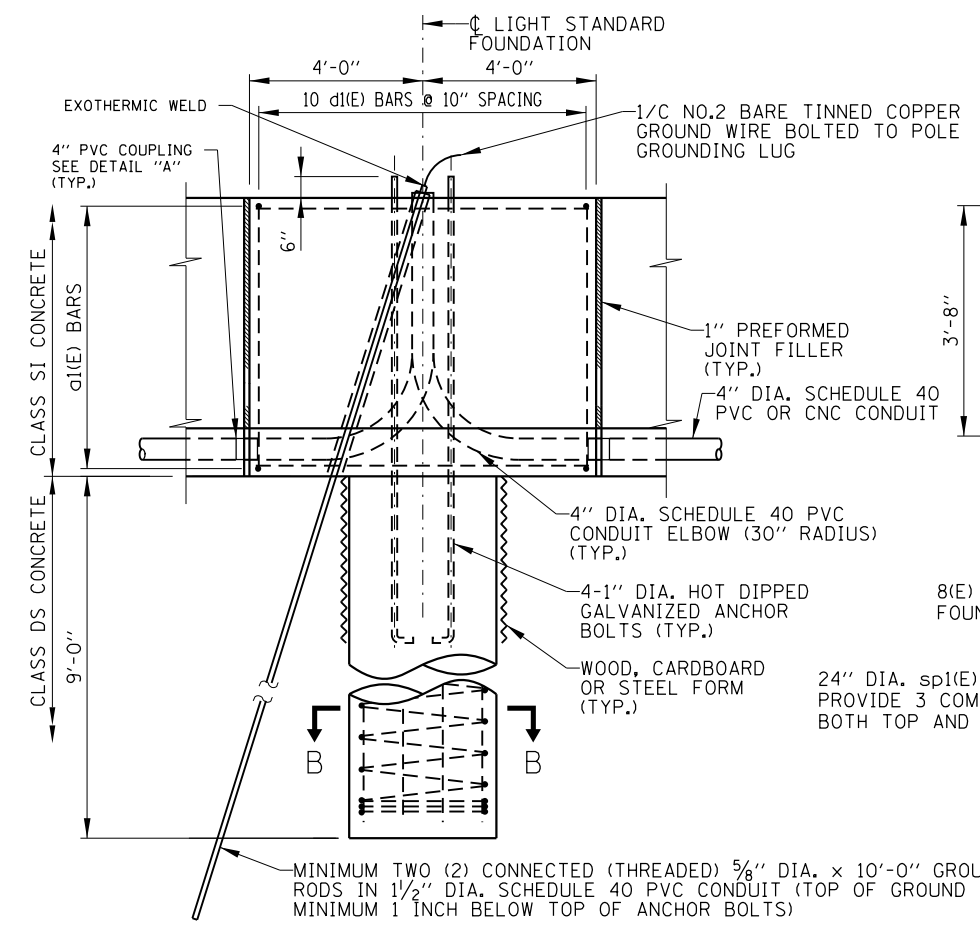
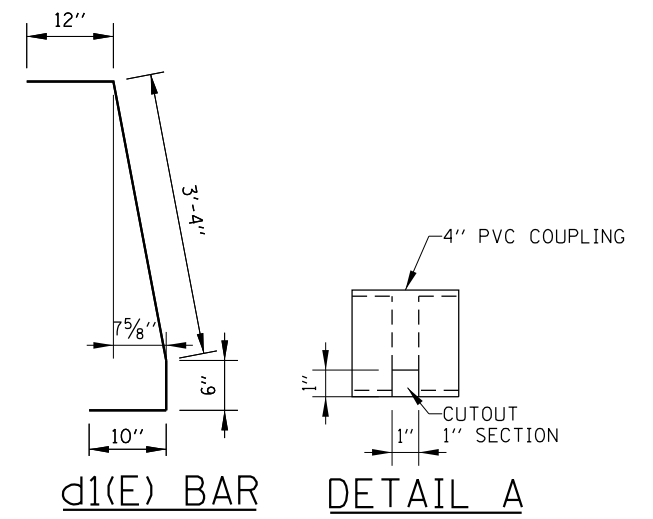
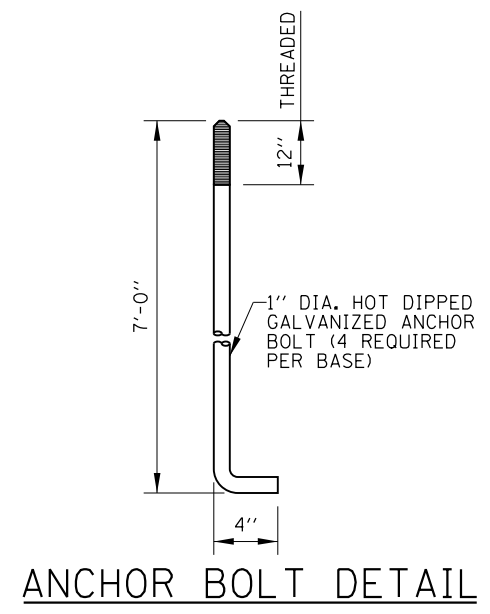
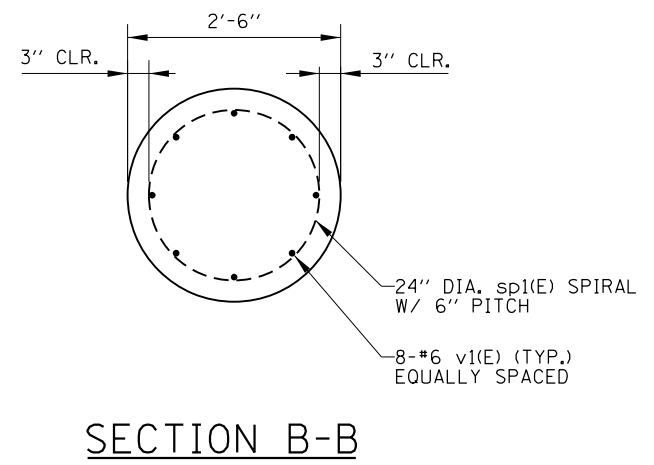
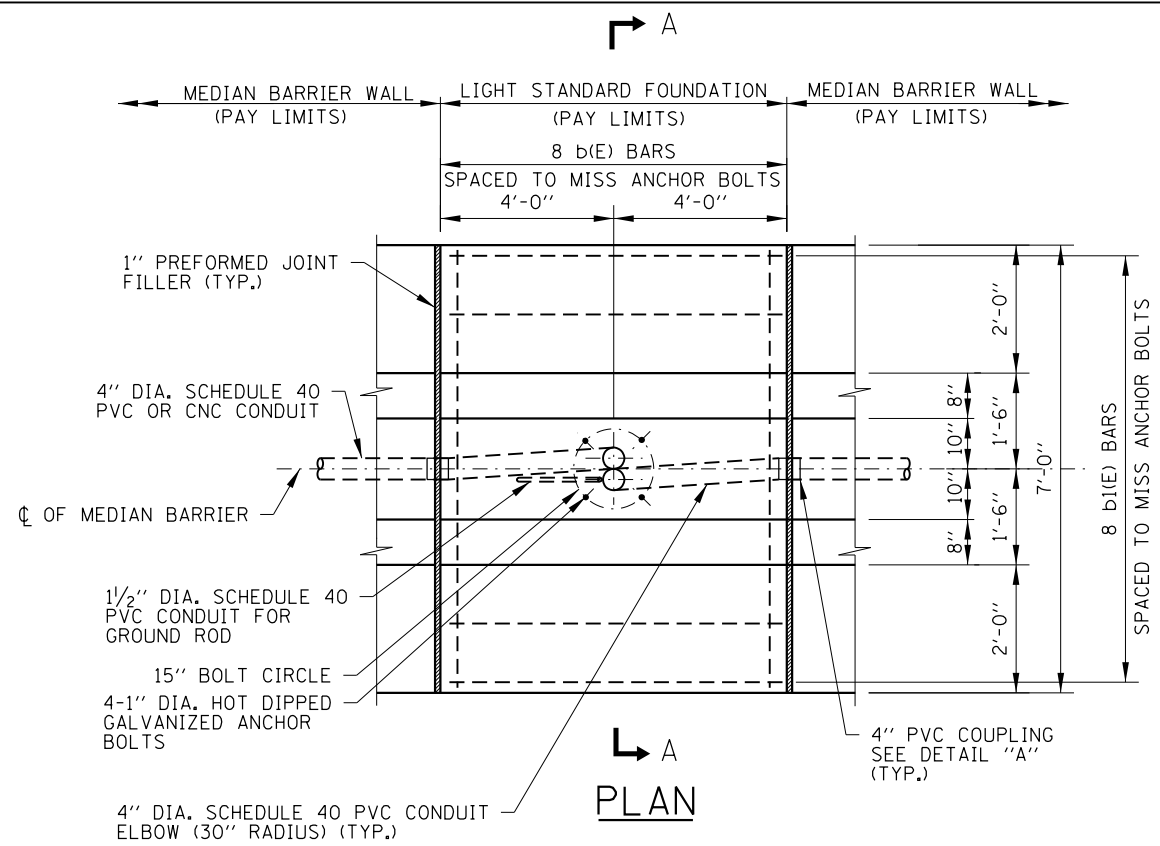

REINFORCEMENT BARS SCHEDULE					
BAR	NO.	SIZE	LENGTH	WT. LB.	SHAPE
d1(E)	12	#4	7'-6"	60	—
b(E)	8	#4	6'-6"	35	—
b1(E)	8	#4	7'-8"	41	—
d1(E)	20	#4	5'-8"	78	┌
sp1(E)	1	#4	*		—
v1(E)	8	#6	11'-9"	142	—

\* SEE SECTION A-A

- NOTES:**
- SEE SHEET 1 OF THIS SERIES FOR NOTES.
  - FOR SLIP FORM, SEE SHEET 6 OF THIS SERIES.



LIGHT STANDARD FOUNDATION

STANDARD H1-09

LIGHT STANDARD FOUNDATION DETAILS - MEDIAN BARRIER  
(TYPE 1 CENTERED CAISSON, 42" BARRIER)

APPROVED: *Paul Kovacs*  
CHIEF ENGINEERING OFFICER DATE: 2-7-2012

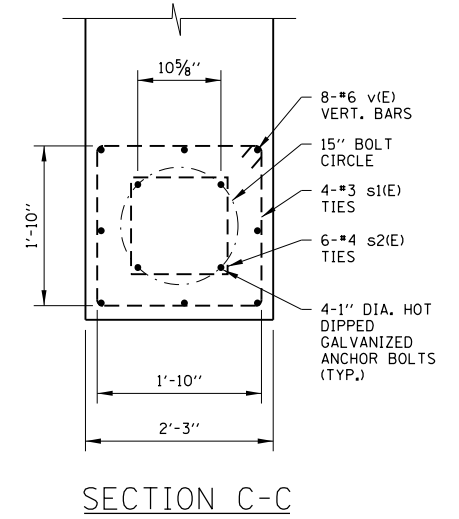
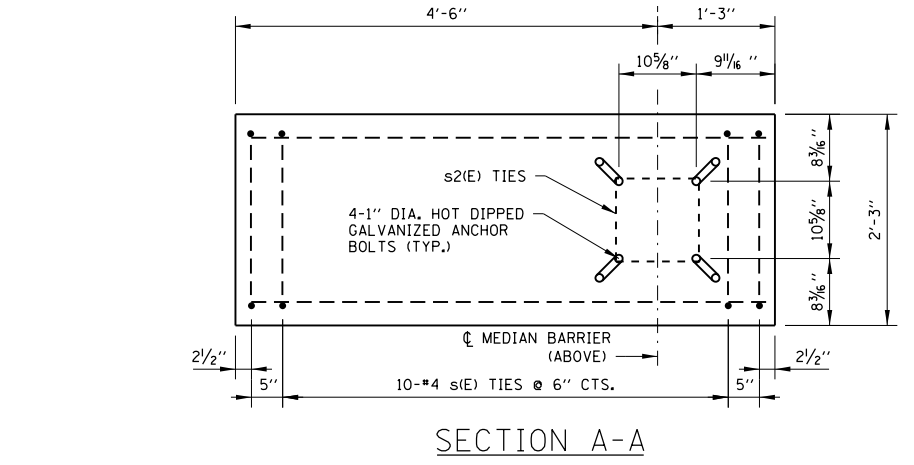
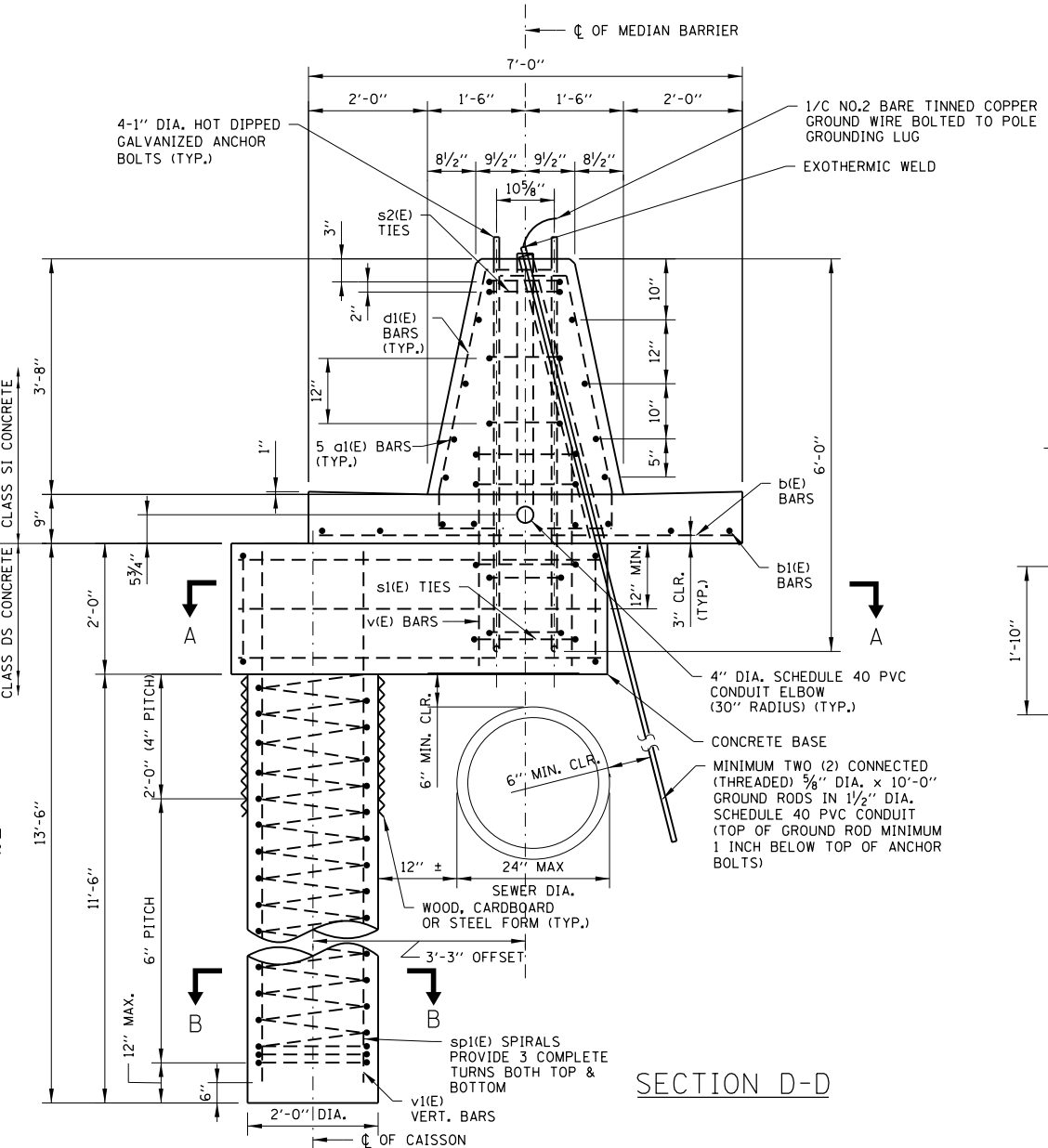
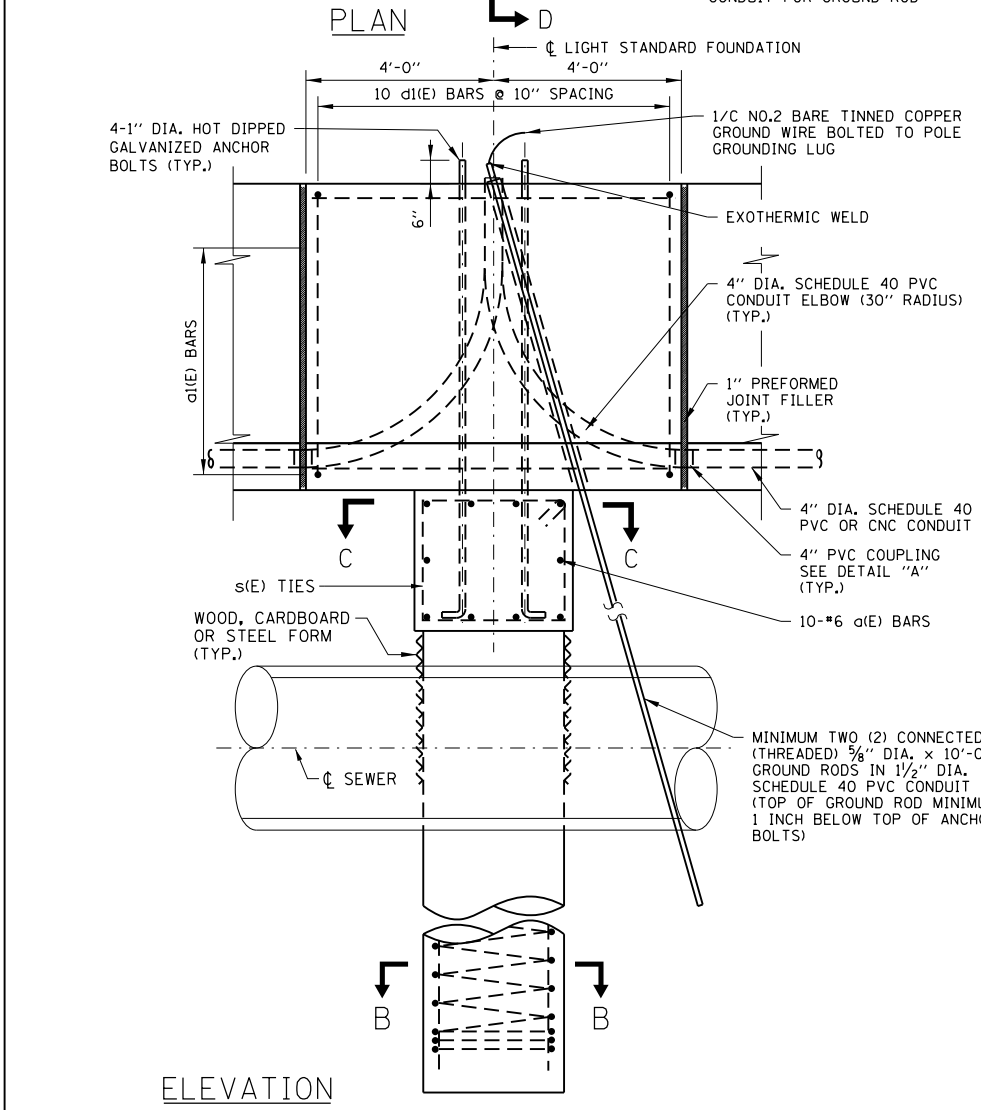
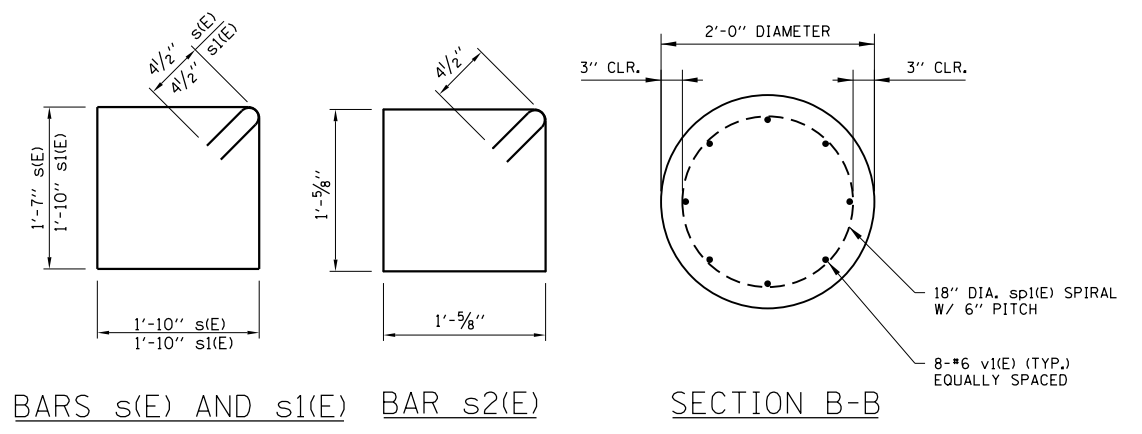
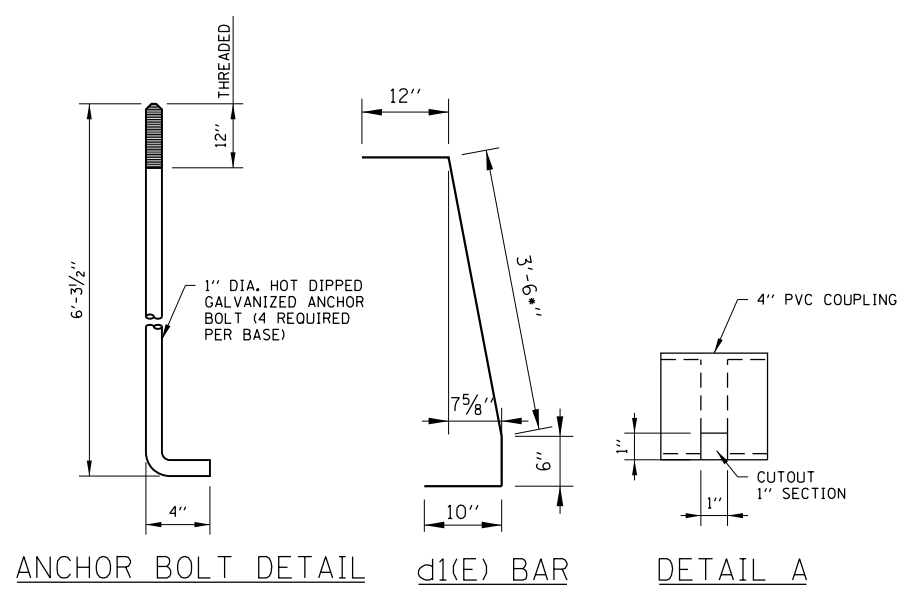
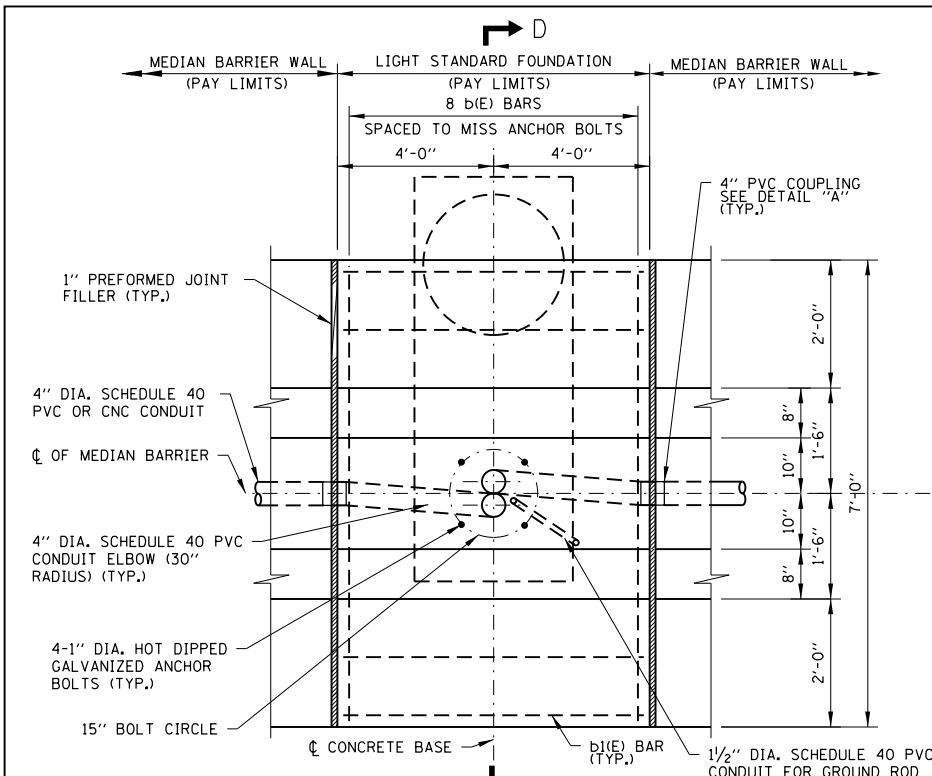

REINFORCEMENT BARS SCHEDULE					
BAR	NO.	SIZE	LENGTH	WT. LB.	SHAPE
a(E)	10	#6	5'-6"	83	
a1(E)	10	#4	7'-6"	50	
b(E)	8	#4	6'-6"	35	
b1(E)	8	#4	7'-8"	78	
d1(E)	20	#4	5'-8"	78	
s(E)	12	#4	7'-7"	61	
s1(E)	4	#4	8'-1"	22	
s2(E)	6	#4	5'-0"	20	
sp1(E)	1	#4	*		
v(E)	8	#6	3'-2"	38	
v1(E)	8	#6	12'-6"	150	

\* SEE D-D



LIGHT STANDARD FOUNDATION

STANDARD H1-09

APPROVED: *Paul Kovacs*  
CHIEF ENGINEERING OFFICER  
DATE: 2-7-2012

LIGHT STANDARD FOUNDATION DETAILS - MEDIAN BARRIER  
(TYPE 2 OFFSET CAISSON, 42" BARRIER)

- NOTES:
- SEE SHEET 1 OF THIS SERIES FOR NOTES.
  - FOR SLIP FORM, SEE SHEET 6 OF THIS SERIES

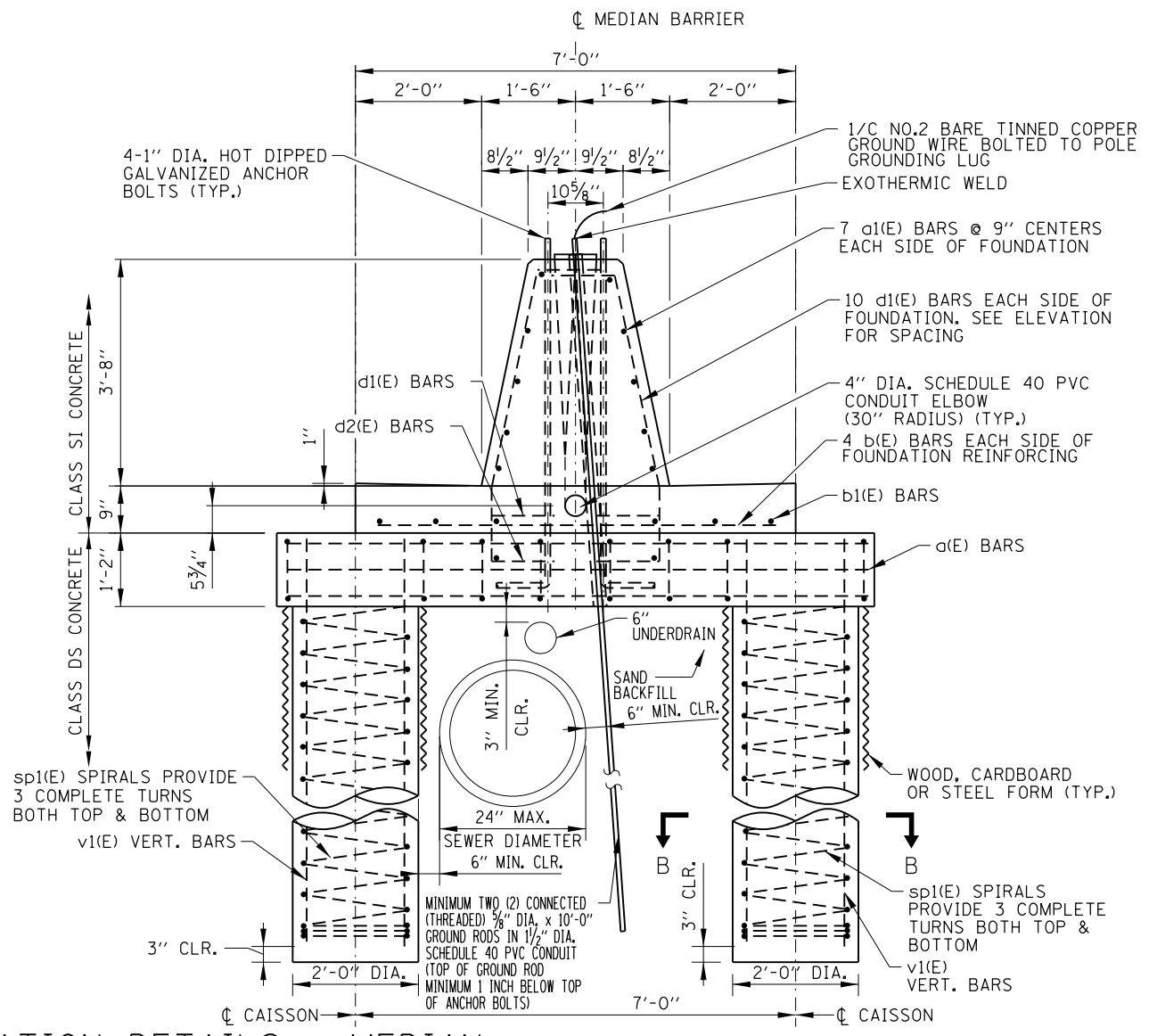
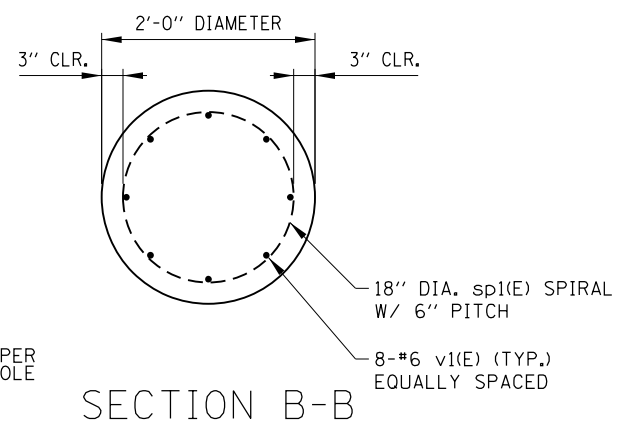
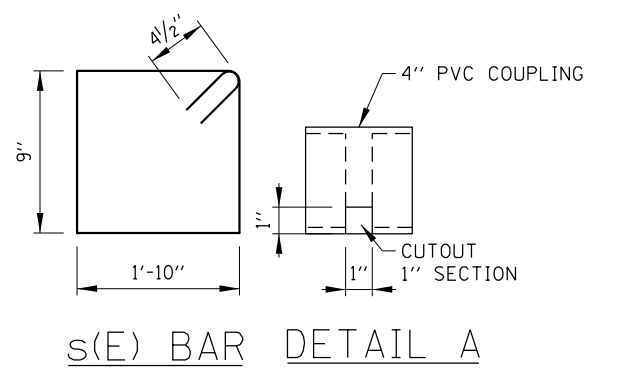
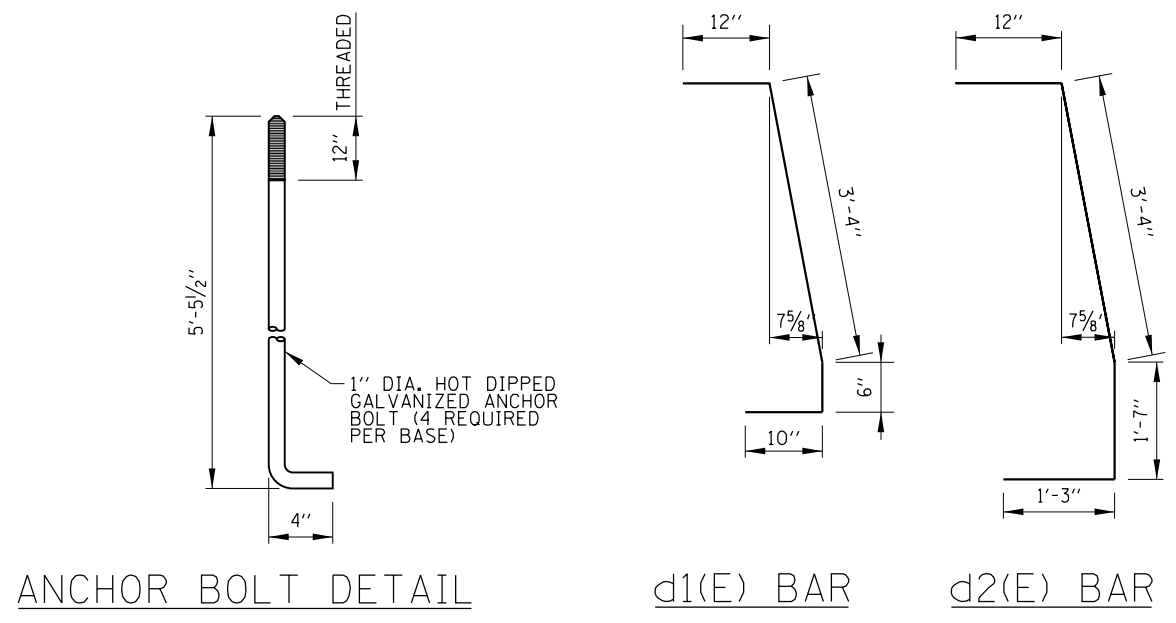
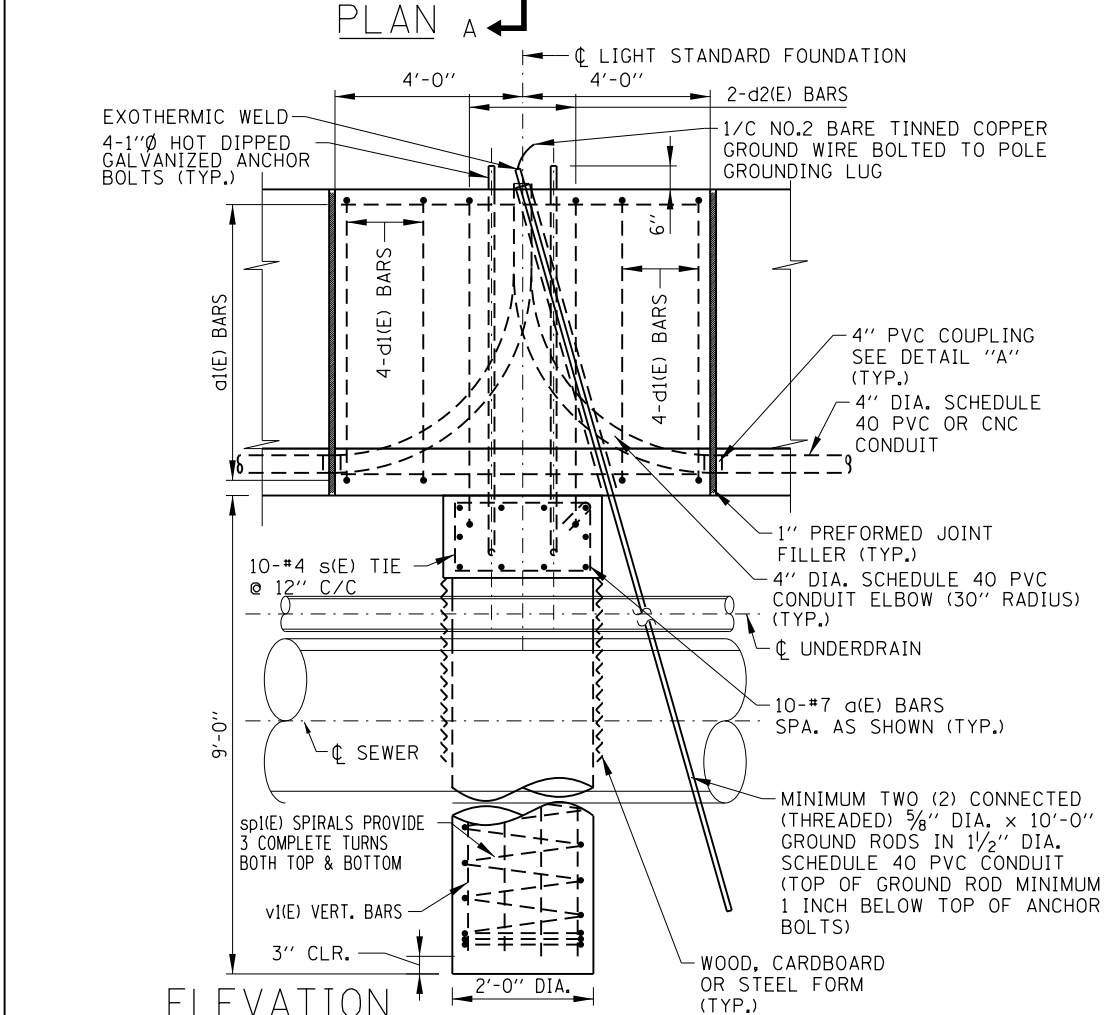
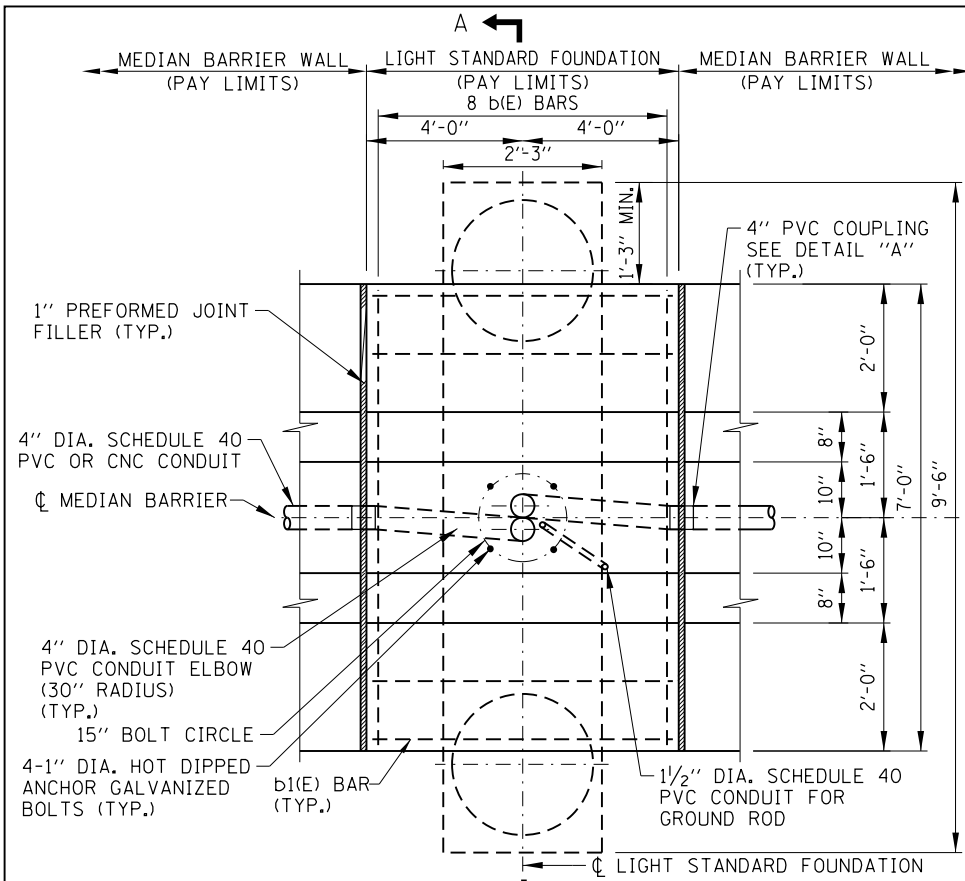

REINFORCEMENT BARS SCHEDULE					
BAR	NO.	SIZE	LENGTH	WT. LB.	SHAPE
a(E)	10	#7	9'-0"	184	
a1(E)	14	#4	7'-6"	70	
b(E)	8	#4	6'-6"	35	
b1(E)	4	#4	7'-8"	21	
d1(E)	16	#4	5'-8"	62	
d2(E)	4	#4	7'-2"	20	
s(E)	10	#4	5'-11"	40	
sp1(E)	2	#4	*		
v1(E)	16	#6	9'-9"	235	

\* SEE ELEVATION

- NOTES:**
- SEE SHEET 1 OF THIS SERIES FOR NOTES.
  - FOR SLIP FORM, SEE SHEET 6 OF THIS SERIES.

Paul Kovacs  
 APPROVED CHIEF ENGINEERING OFFICER DATE 2-7-2012

LIGHT STANDARD FOUNDATION DETAILS - MEDIAN BARRIER (TYPE 3 STRADDLED CAISSON, 42" BARRIER)

SHEET 5 OF 10

LIGHT STANDARD FOUNDATION  
 STANDARD H1-09

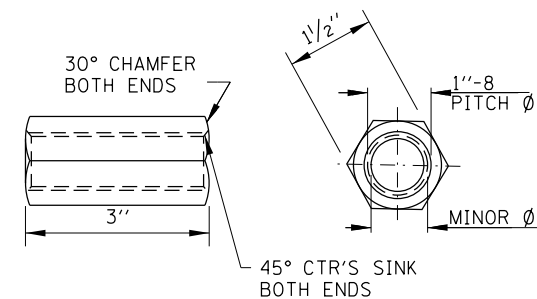
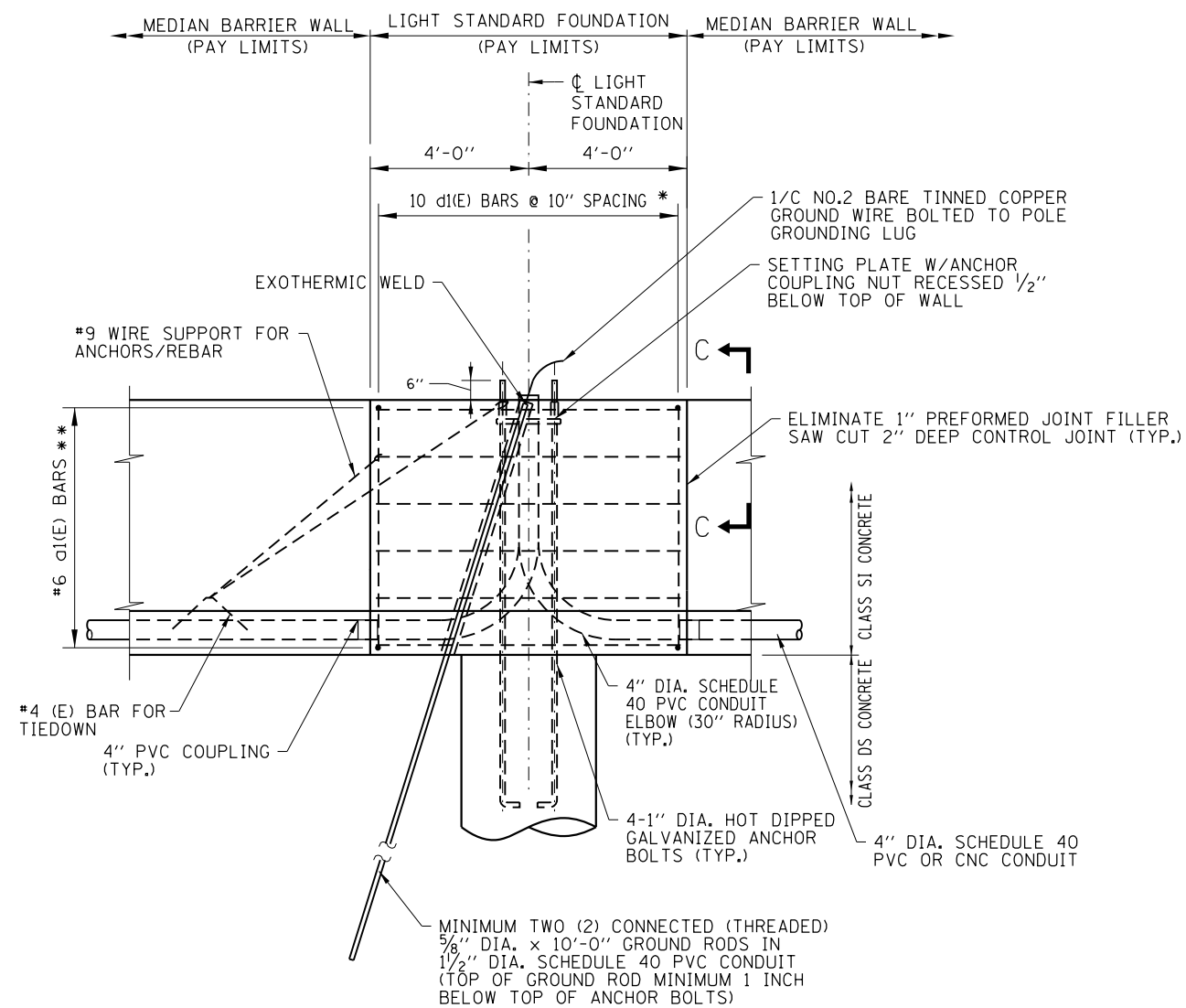
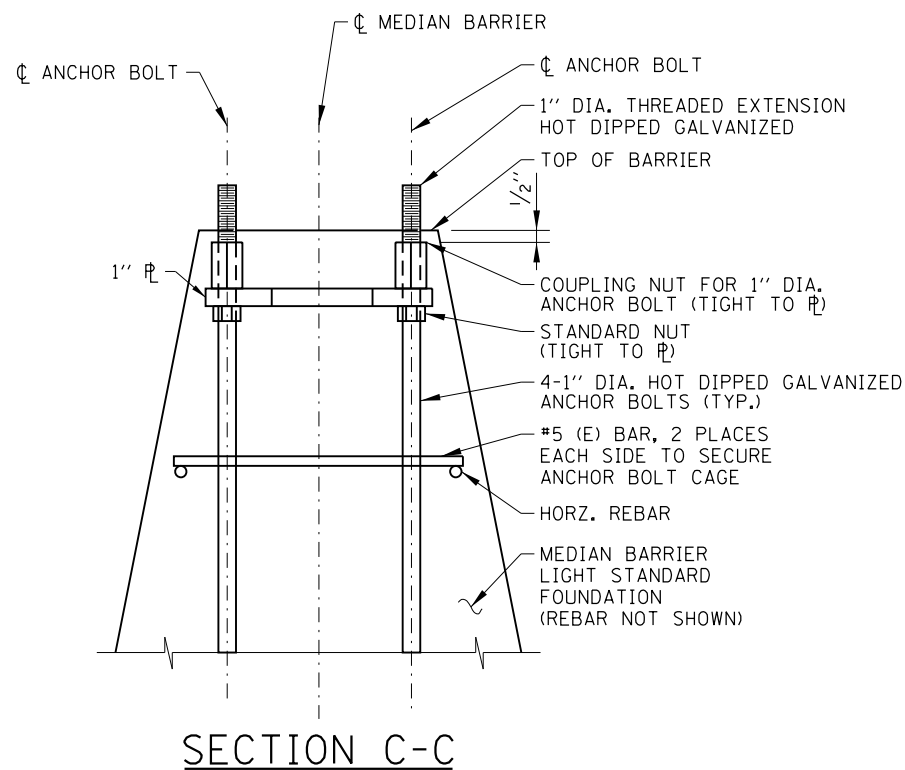

**COUPLING NUT**

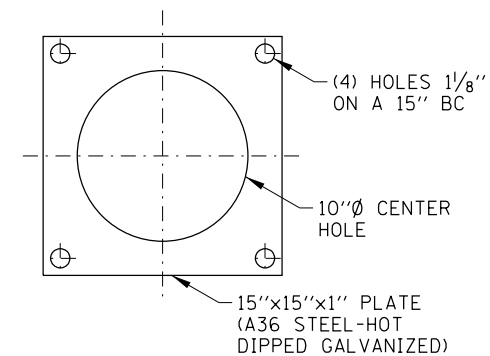

**SETTING PLATE**

\* #6 d1(E) BAR REPLACES #4 d1(E) BAR  
 \*\* #6 d1(E) BAR REPLACES #4 d1(E) BAR

**LIGHT STANDARD FOUNDATION DETAILS - MEDIAN BARRIER  
 (MODIFICATIONS FOR SLIPFORM POUR, 42" BARRIER)**

**NOTES:**

- SEE SHEET 1 OF THIS SERIES FOR NOTES.
- PLUG TOP OF COUPLER WITH PLASTIC PLUG OR COVER WHILE PLACING CONCRETE.

*Paul Kovacs*  
 APPROVED, CHIEF ENGINEERING OFFICER DATE 2-7-2012

**Illinois Tollway**

LIGHT STANDARD FOUNDATION

STANDARD H1-09

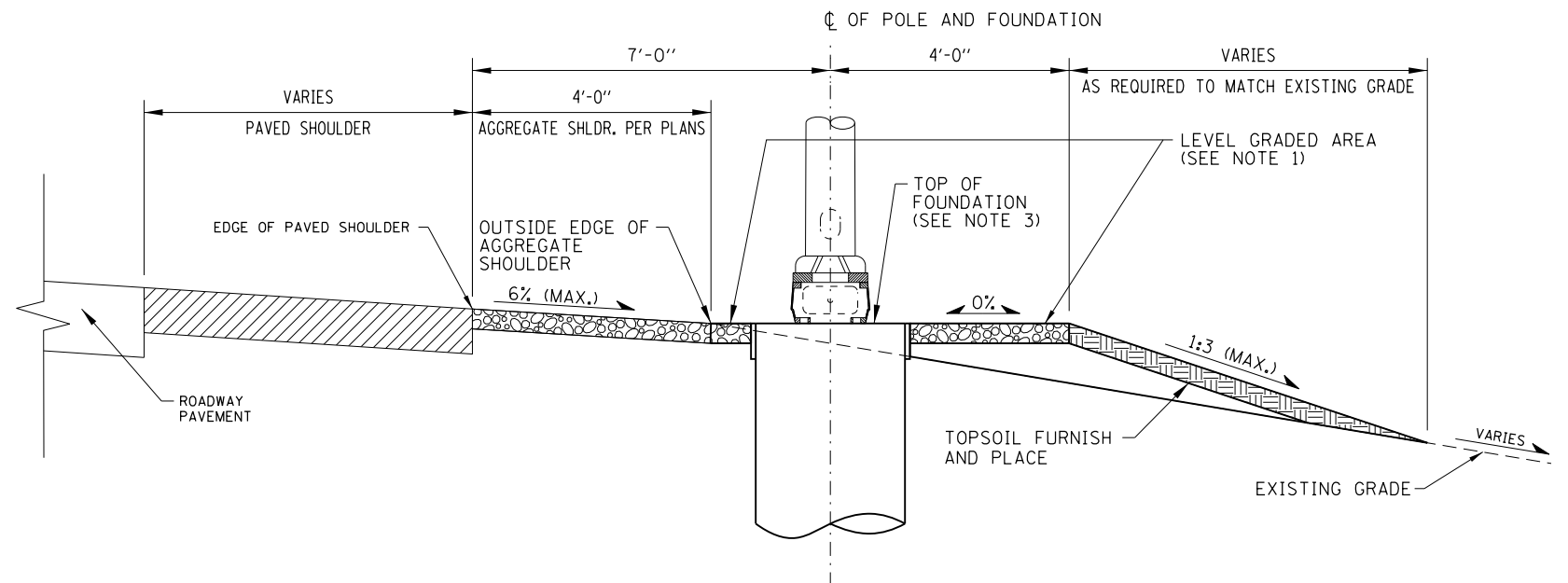
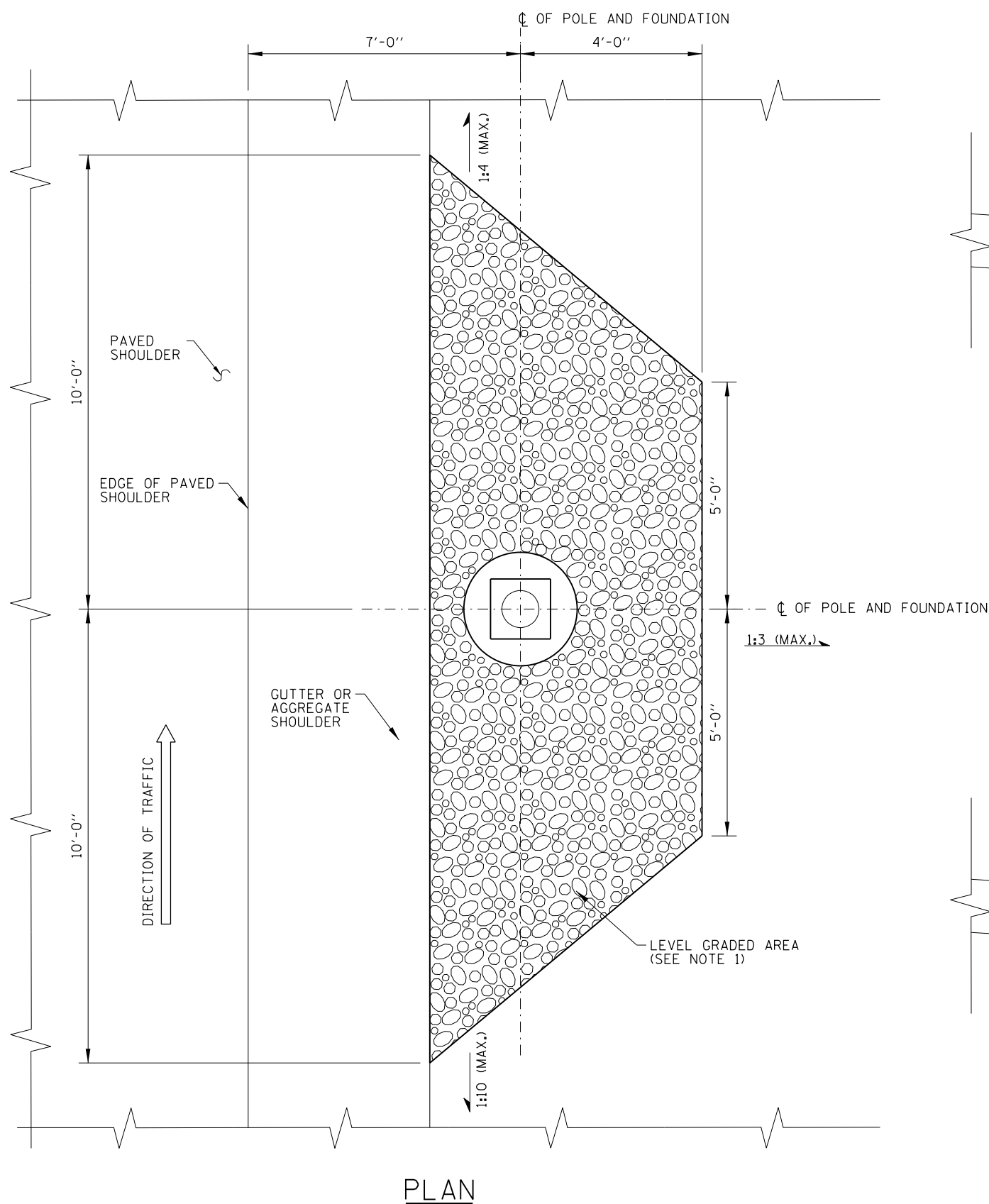

LIGHT STANDARD FOUNDATION  
ADJACENT TO AGGREGATE SHOULDER

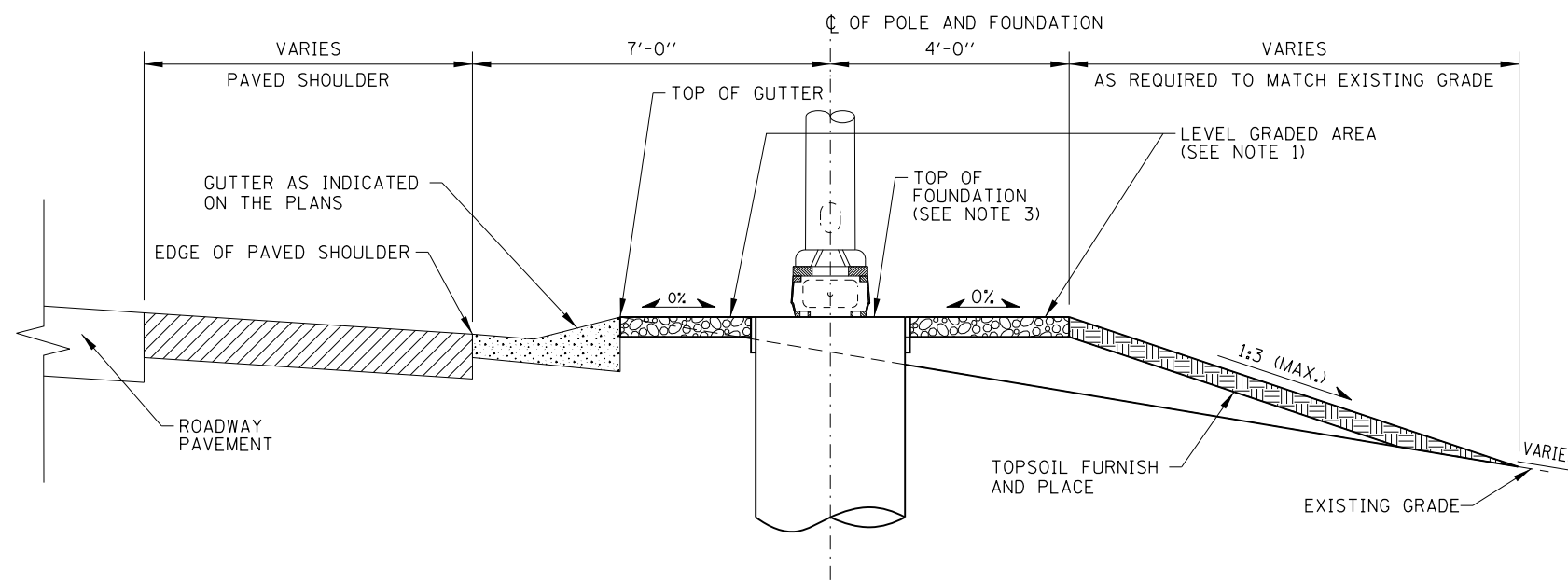

LIGHT STANDARD FOUNDATION  
ADJACENT TO GUTTER

LIGHT STANDARD FOUNDATION DETAILS - GRADING W/ FORESLOPE  
(GROUND MOUNTED UNITS)

APPROVED: *Paul Kovacs*  
CHIEF ENGINEERING OFFICER DATE: 2-7-2012

NOTE:  
SEE SHEET 1 OF THIS SERIES FOR NOTES.

SHEET 7 OF 10



LIGHT STANDARD  
FOUNDATION

STANDARD H1-09



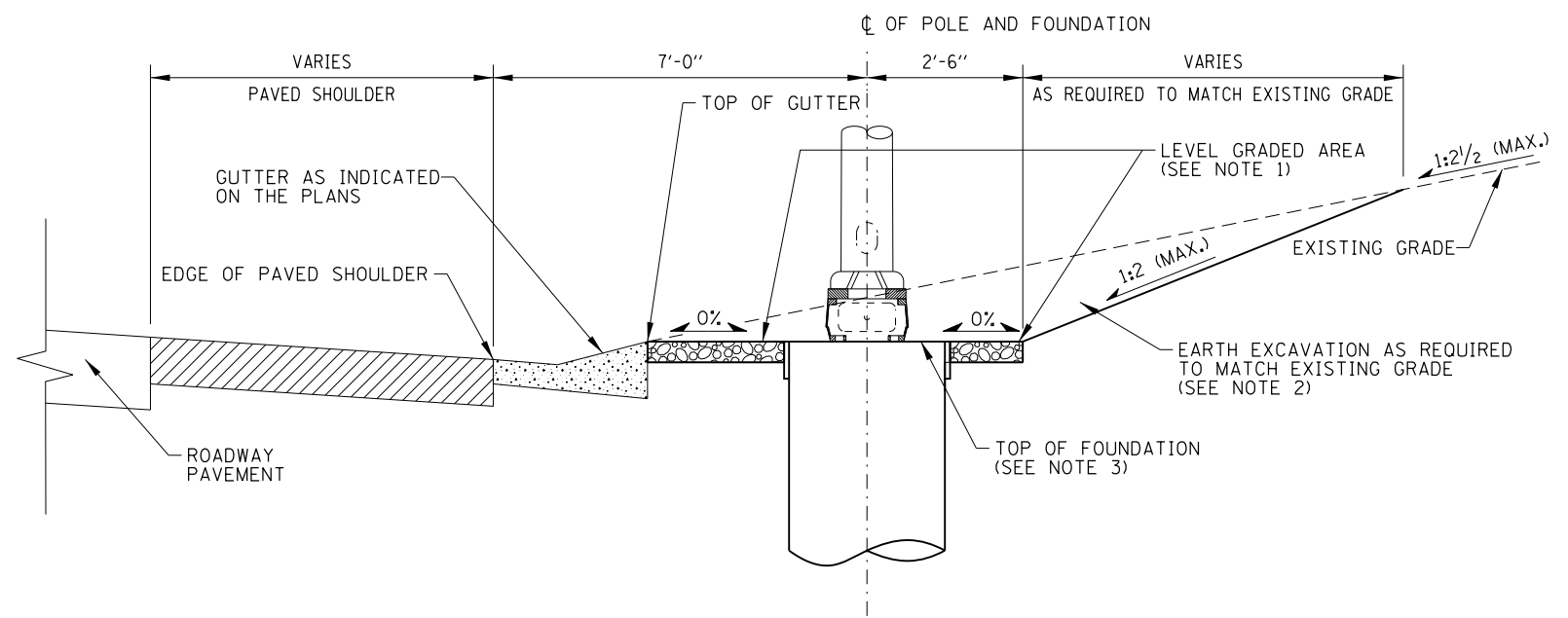
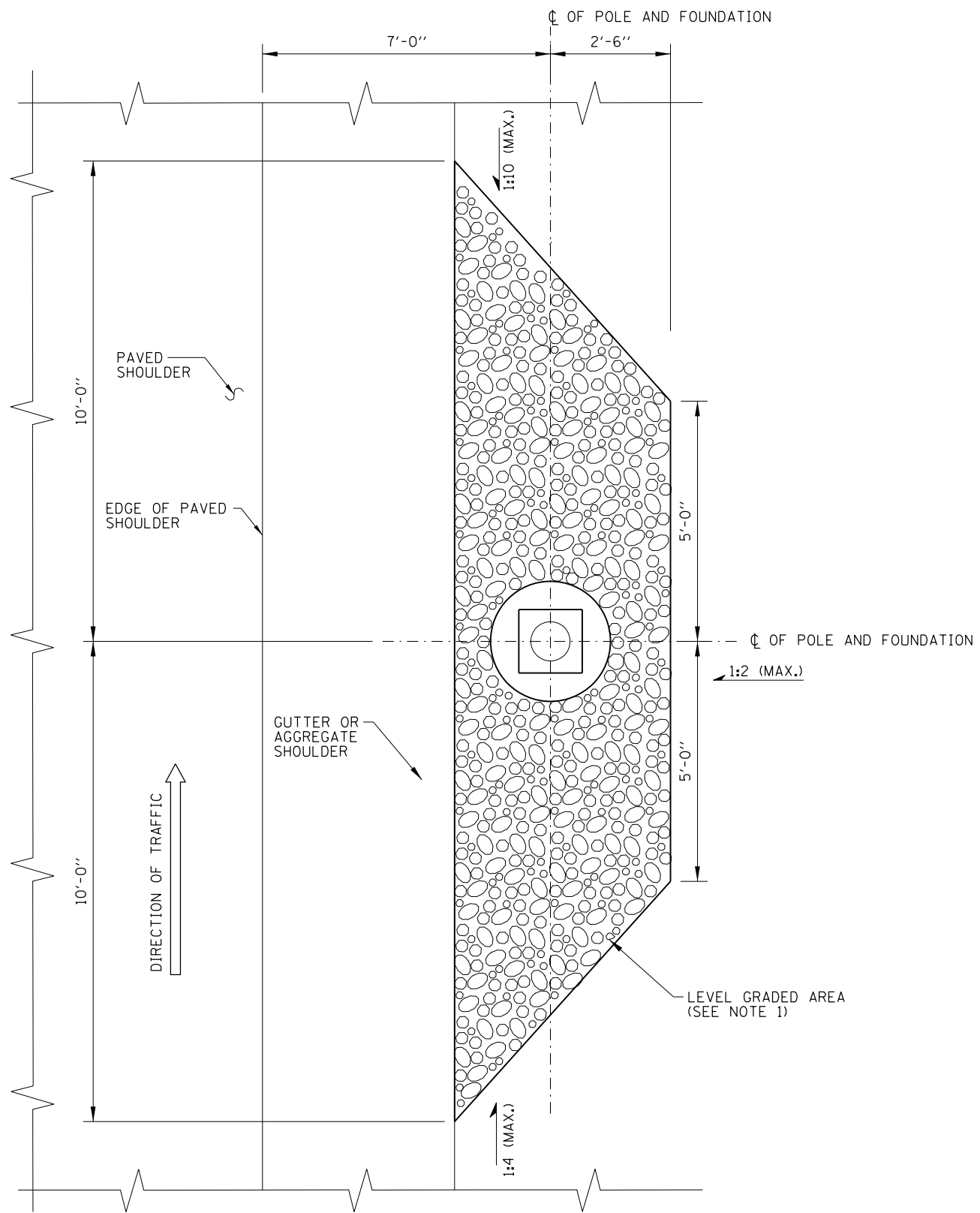

LIGHT STANDARD FOUNDATION  
ADJACENT TO GUTTER

LIGHT STANDARD FOUNDATION DETAILS - GRADING W/ BACKSLOPE  
(GROUND MOUNTED UNITS)

APPROVED: *Paul Kovacs*  
CHIEF ENGINEERING OFFICER DATE: 2-7-2012

NOTE:  
SEE SHEET 1 OF THIS SERIES FOR NOTES.



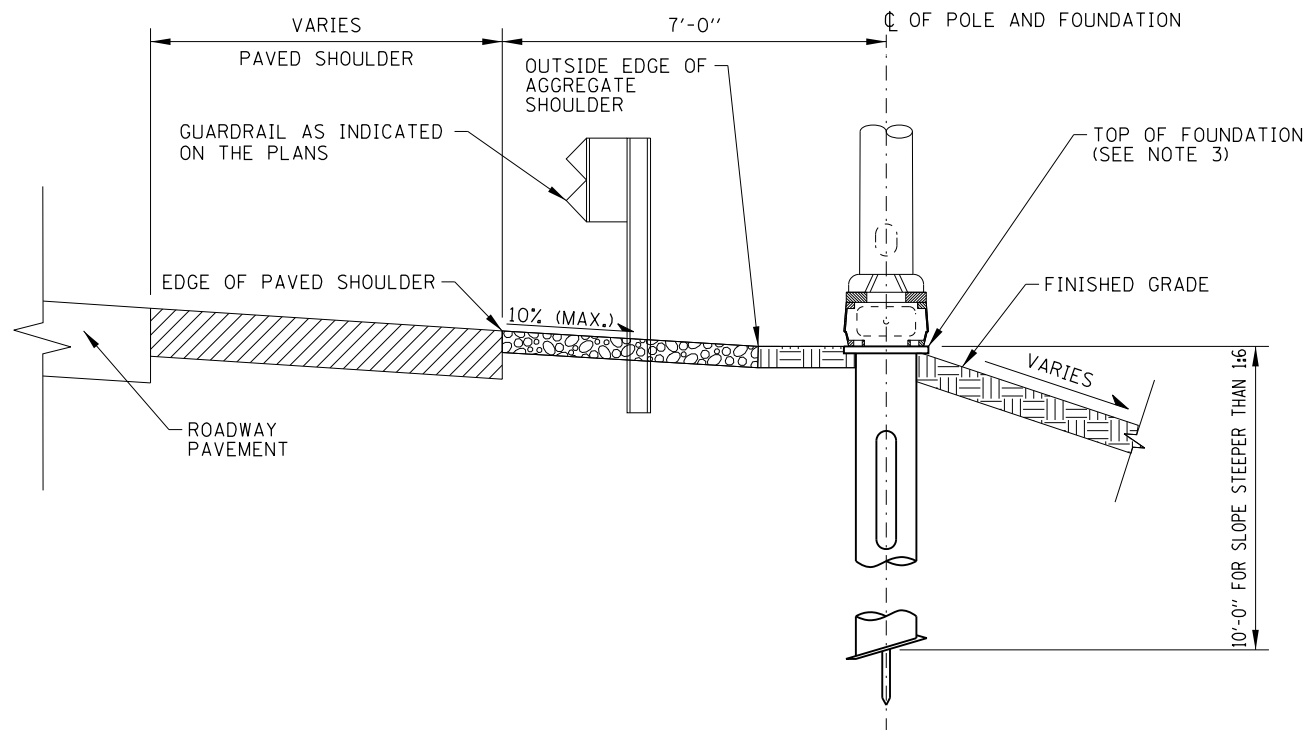

LIGHT STANDARD FOUNDATION - HELIX  
ADJACENT TO AGGREGATE SHOULDER

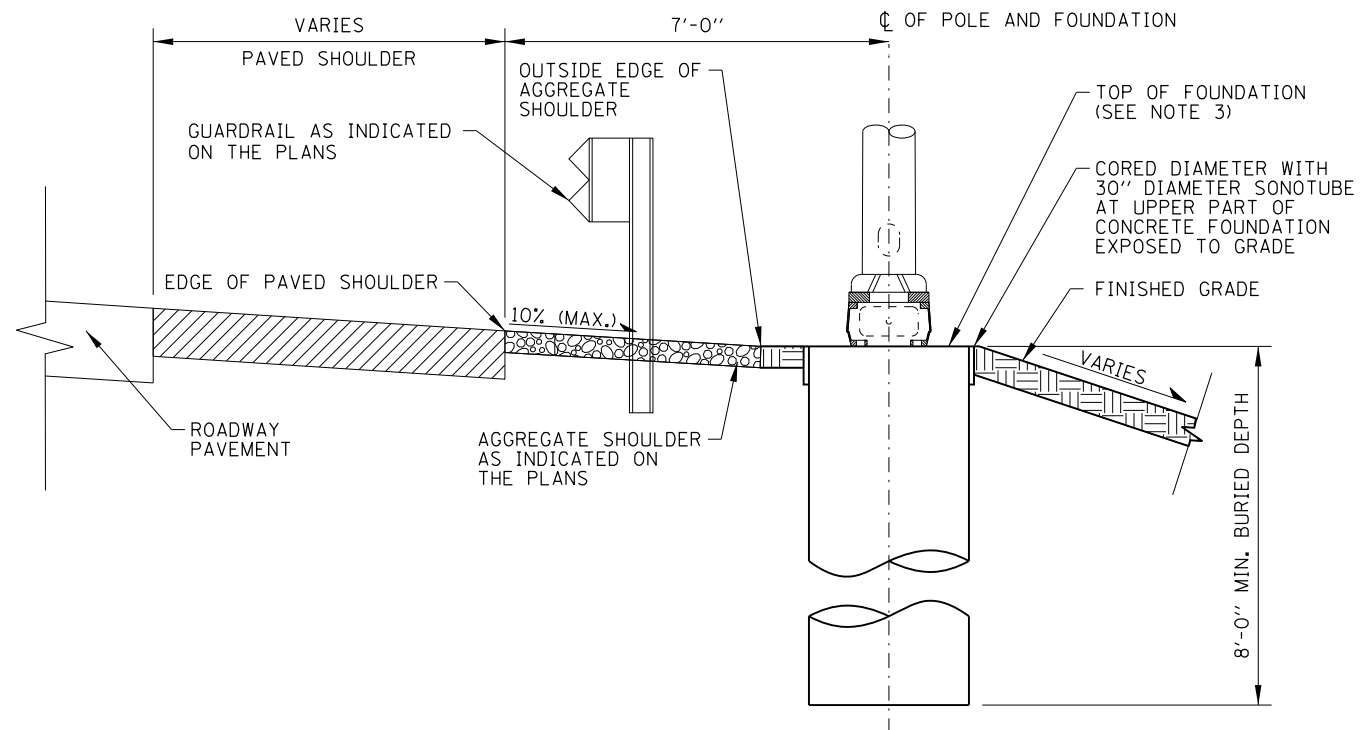

LIGHT STANDARD FOUNDATION - CONCRETE  
ADJACENT TO AGGREGATE SHOULDER

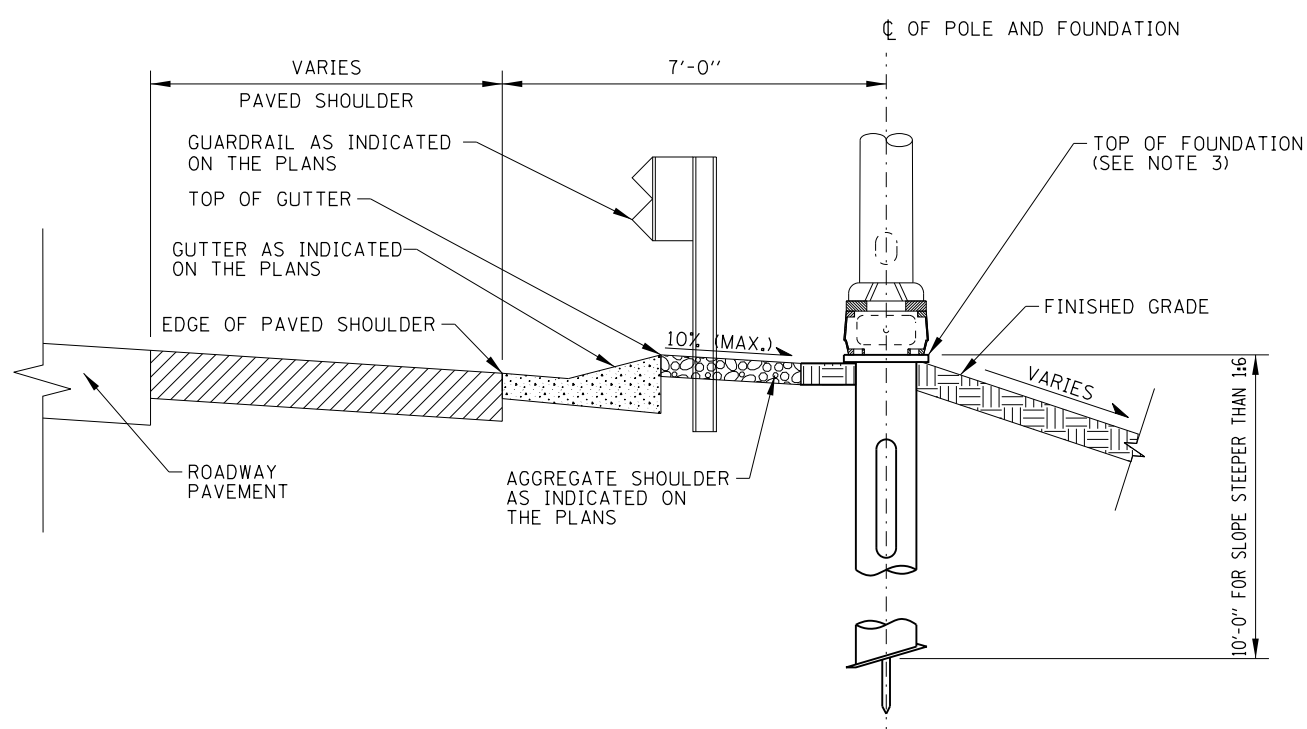

LIGHT STANDARD FOUNDATION - HELIX  
ADJACENT TO GUTTER

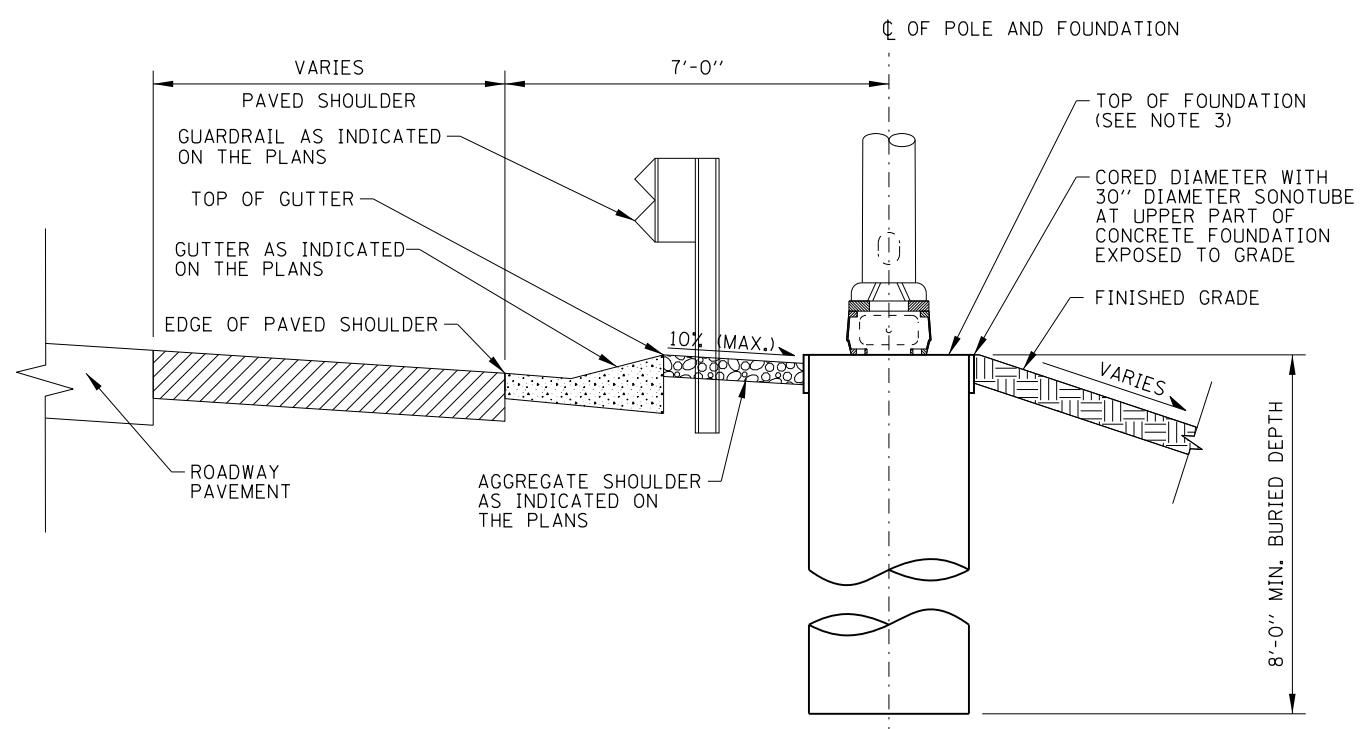

LIGHT STANDARD FOUNDATION - CONCRETE  
ADJACENT TO GUTTER

LIGHT STANDARD FOUNDATION DETAILS - ADJACENT TO GUARDRAIL  
(GROUND MOUNTED UNITS)

APPROVED: *Paul Kovacs*  
CHIEF ENGINEERING OFFICER DATE: 2-7-2012

NOTE:  
SEE SHEET 1 OF THIS SERIES FOR NOTES.

SHEET 9 OF 10

LIGHT STANDARD  
FOUNDATION

STANDARD H1-09

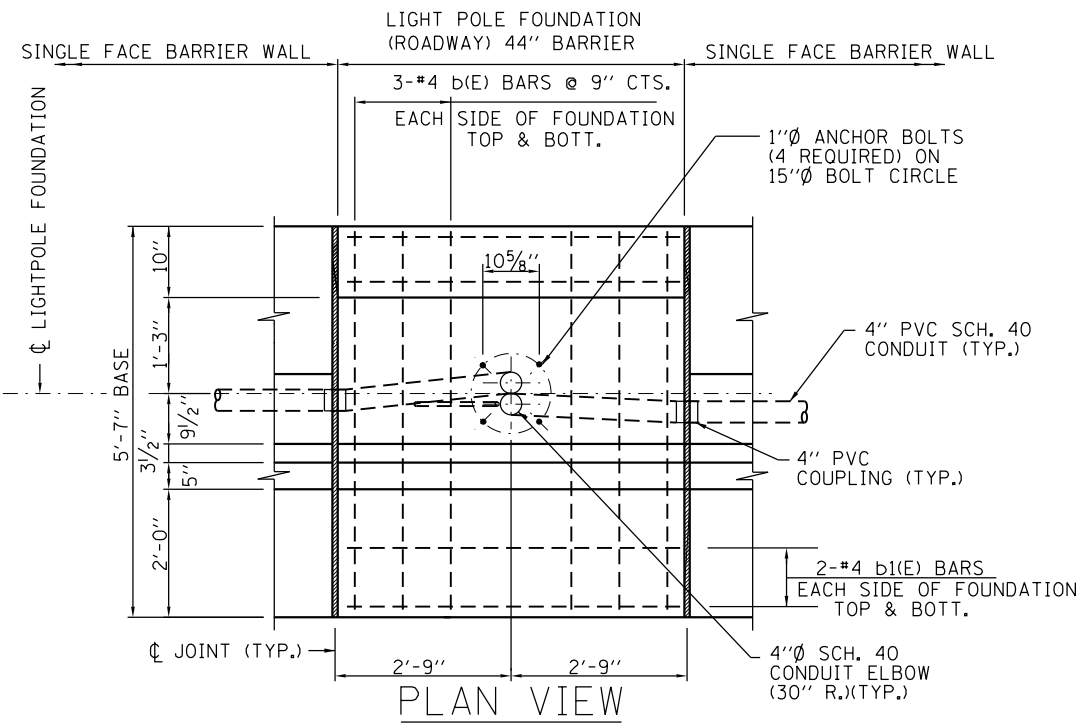

**NOTES:**

1. ALL BARS SHALL BE EPOXY COATED.
2. CONCRETE, REINFORCEMENT BARS, ANCHOR BOLTS, AND ALL OTHER COMPONENTS OF THE LIGHT POLE FOUNDATION ARE INCLUDED IN THE COST OF LIGHT POLE FOUNDATION (ROADWAY) 44" BARRIER.

REINFORCING BAR SCHEDULE					
BAR	NO.	SIZE	LENGTH	WT. LBS.	SHAPE
a1(E)	12	#4	5'-0"	40	—
b(E)	12	#4	5'-1"	41	—
b1(E)	8	#4	5'-2"	28	—
d1(E)	6	#4	6'-11"	28	⌋
d2(E)	6	#4	7'-0"	27	⌋
sp1(E)	•	#4	•	•	⌋
v1(E)	8	#6	12'-6"	150	—

• SEE SECT. A-A

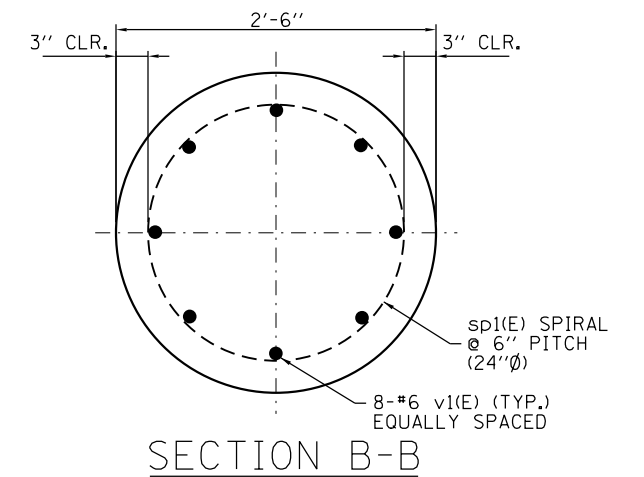
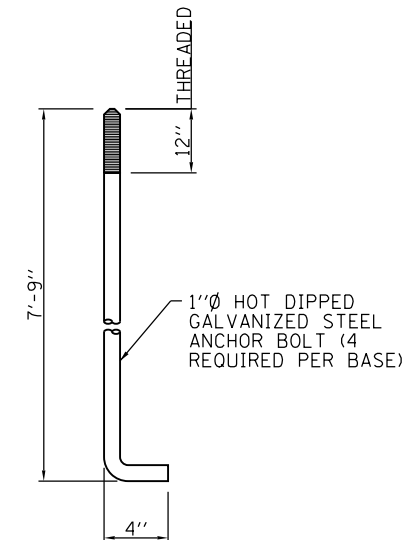
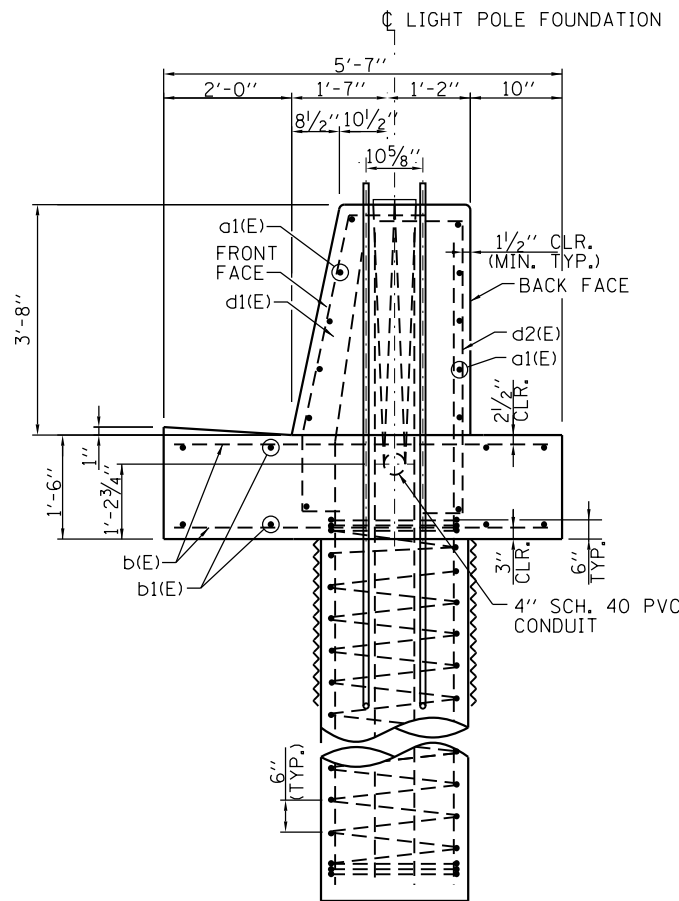
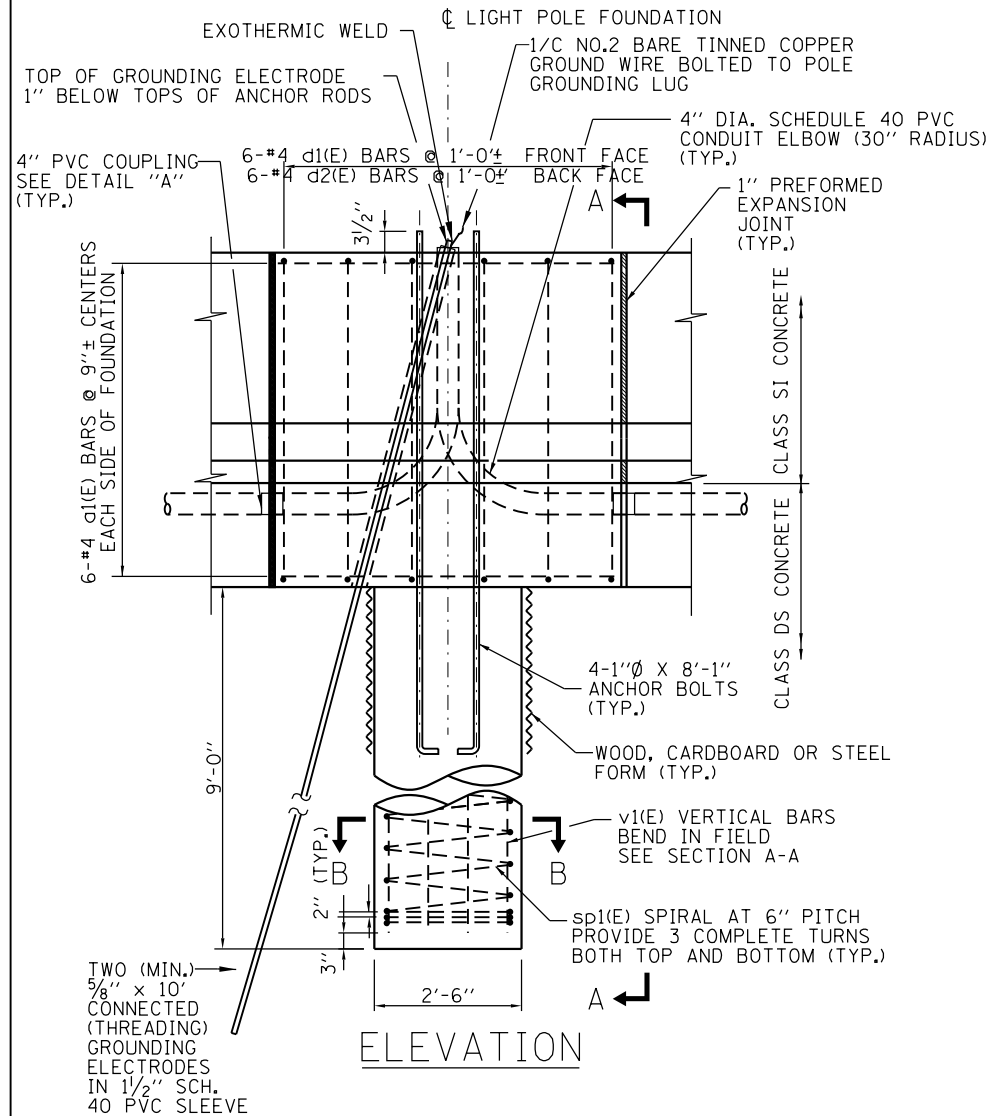
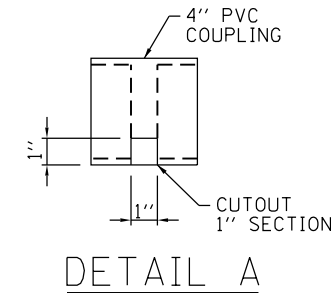
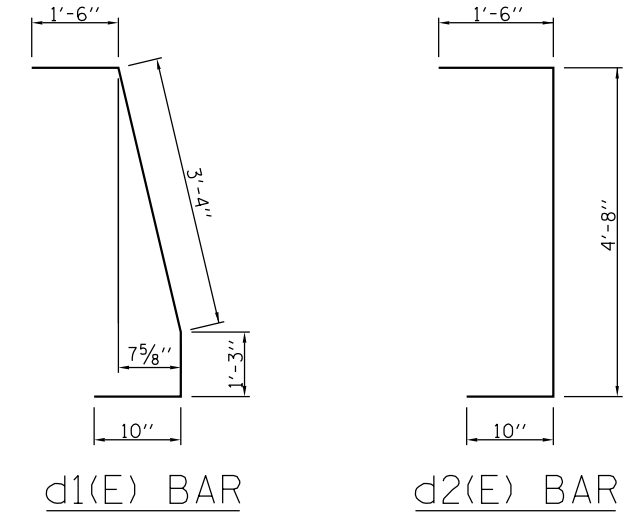

SECTION A-A

ANCHOR BOLT DETAIL

ELEVATION

SECTION B-B



*Paul Kovacs*

APPROVED, CHIEF ENGINEERING OFFICER

DATE 3-1-2020

LIGHT STANDARD FOUNDATION DETAILS - SINGLE FACE BARRIER

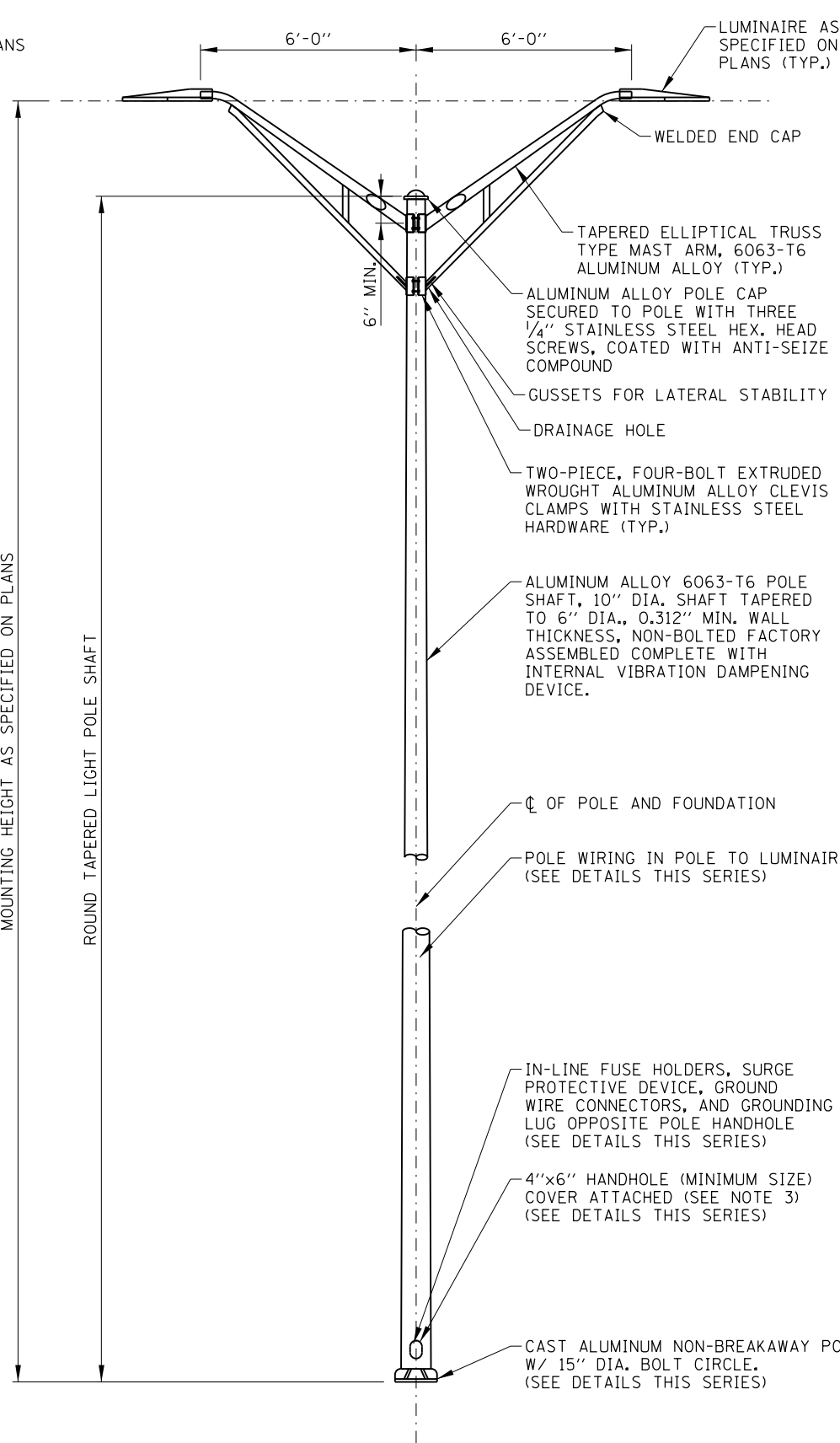
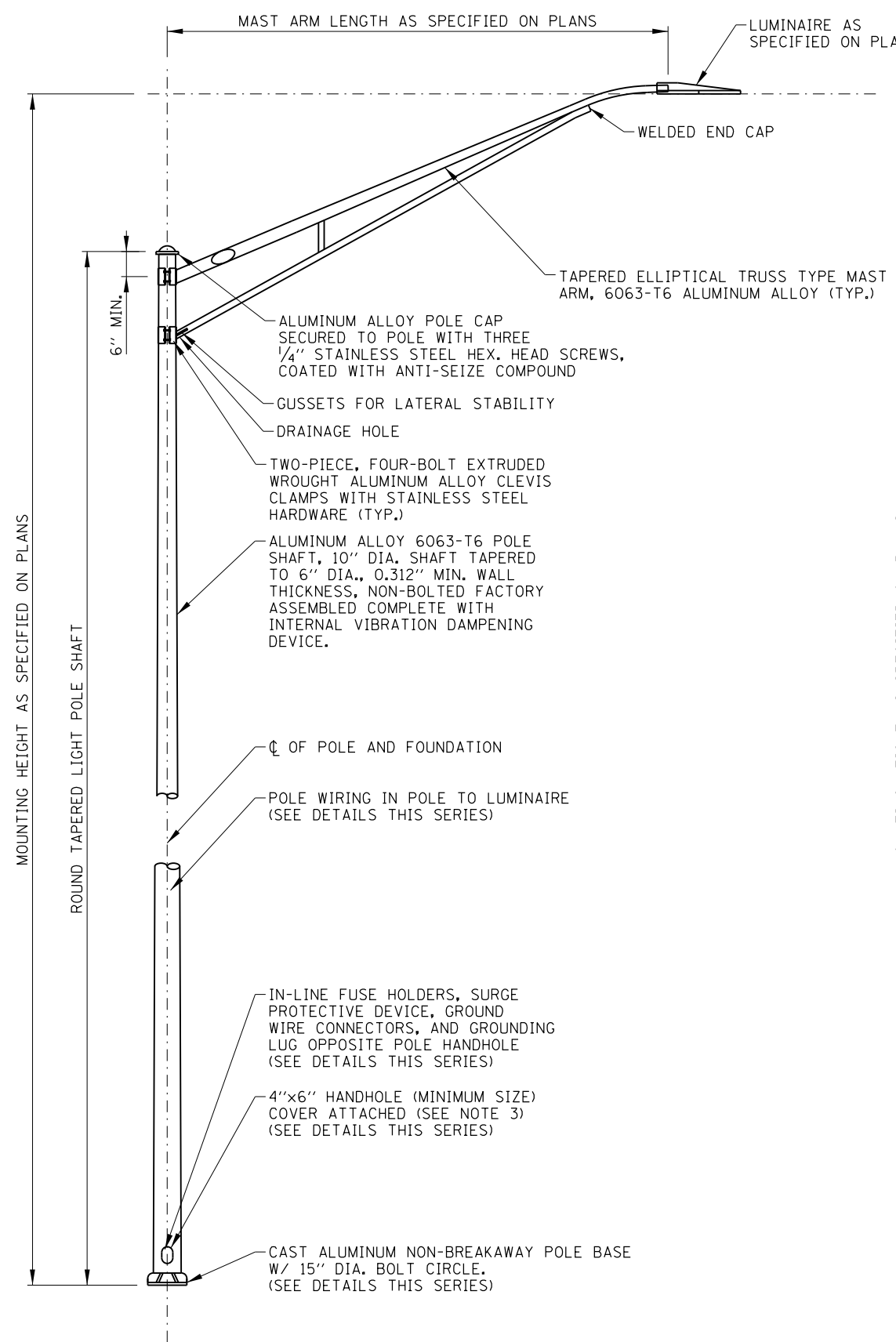

**NOTES:**

1. ALL LIGHT STANDARDS, BOTH NEW AND EXISTING, ARE SHOWN ON PLANS WITH THE SAMPLE DESCRIPTIONS SHOWN ON THIS SHEET.
2. FOR FOUNDATION DETAILS SEE STANDARD H1. FOR STRUCTURAL PARAPET FOUNDATION DETAILS, SEE STRUCTURAL PLANS.
3. HANDHOLE COVERS SHALL BE FASTENED USING TWO STAINLESS STEEL SCREWS WITH CAPTIVE STAINLESS STEEL NUTS OR INSERTS, PER ILLINOIS TOLLWAY SUPPLEMENTAL SPECIFICATION SECTION 1069.
4. PROVIDE A 24" LONG POLYETHYLENE TUBE TO PROTECT CABLES WHERE THEY PASS THROUGH THE GROMMETTED OPENING AT THE POLE/MAST ARM JUNCTION.
5. ALL GROUND MOUNTED LIGHT POLES SHALL BE PROVIDED WITH AN ACCEPTED FHWA BREAKAWAY BASE OR DEVICE PER THE ILLINOIS TOLLWAY SUPPLEMENTAL SPECIFICATIONS SECTION 1070.
6. EACH BRIDGE MOUNTED LIGHT STANDARD SHALL BE PROVIDED WITH SHOCK ABSORBING VIBRATION PADS, NUTS, WASHERS, LEVELING PLATE AND WIRE MESH FOR ITS ERECTION ON THE FOUNDATION AS SHOWN ON THE PLANS.
7. LIGHT STANDARD WIRING DETAIL FOR INSTALLATION WITH CONCRETE FOUNDATION SHOWN. DETAIL FOR INSTALLATION WITH HELIX FOUNDATION IS SIMILAR.
8. LIGHT STANDARD WIRING DETAILS SHOWN FOR TWIN MAST ARM (2 LUMINAIRES PER POLE) INSTALLATIONS. SINGLE MAST ARM (1 LUMINAIRE PER POLE) INSTALLATIONS SHALL OMIT TWO (2) IN-LINE FUSE HOLDERS, ONE SURGE PROTECTION DEVICE AND ASSOCIATED WIRING.
9. CONDUCTORS EXTENDED INTO LIGHT POLE BASE SHALL BE OF SUFFICIENT LENGTH TO WITHDRAW SPLICES AND/OR INSULATED JOINTS A MINIMUM 18" OUT OF THE POLE HANDHOLE.
10. ALL CONDUCTORS ORIGINATING IN POLE SHALL BE A 1/C NO. 10 AWG UNLESS OTHERWISE NOTED.
11. ALL EQUIPMENT SHALL BE GROUNDED AND BONDED IN ACCORDANCE WITH THE NATIONAL ELECTRICAL CODE AND THE NATIONAL ELECTRICAL SAFETY CODE.
12. WASHERS BETWEEN HEX NUTS AND POLE BASES SHALL BE 2.5" OUTER DIAMETER. WASHERS ON PARAPET OR MEDIAN MOUNTED LIGHT POLES SHALL BE MINIMUM 1/4" THICK. BENT OR DEFORMED WASHERS OR DAMAGED POLE BASES WILL NOT BE ACCEPTED. MULTIPLE STACKED WASHERS SHALL NOT BE SUBSTITUTED FOR APPROPRIATELY SIZED WASHERS.
13. ANCHOR BOLTS SHALL EXTEND OVER THE TOP OF HEX NUTS AND SHALL HAVE SUFFICIENT THREAD EXPOSED FOR LOCK NUT TABS TO MAKE CONTACT.

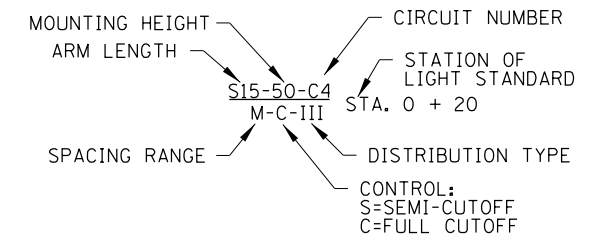

**LIGHT STANDARD DESCRIPTION - HPS LUMINAIRES**

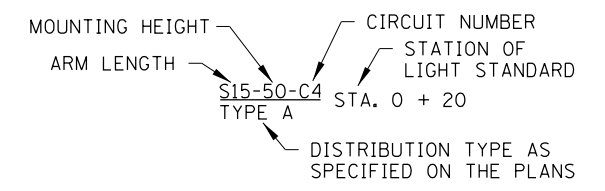

**LIGHT STANDARD DESCRIPTION - LED LUMINAIRES**

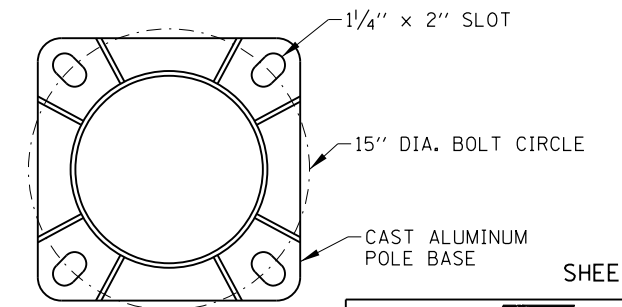

**POLE BASE**

**LIGHT STANDARD - SINGLE MAST ARM**

**LIGHT STANDARD - TWIN MAST ARM**

**LIGHT STANDARD DETAILS**

APPROVED: *Paul Kovacs*  
 CHIEF ENGINEERING OFFICER DATE: 2-7-2012

DATE	REVISIONS
3-11-2015	REVISED LIGHT STANDARD POLE WIRING DETAILS.
3-31-2016	REVISED BARRIER WALL UNIT MOUNTING DETAILS.
3-31-2017	REVISED LIGHT POLE AND MAST ARM DETAILS.
	REVISED WIRING DETAILS: GROUNDING & SPLICES.
3-01-2018	REVISED LIGHT POLE AND MAST ARM DETAILS.
3-01-2019	REVISED LIGHT POLE AND MAST ARM DETAILS.
3-01-2020	REMOVED BOLT COVERS.

**Illinois Tollway**

**LIGHT STANDARD DETAILS**

STANDARD H2-08

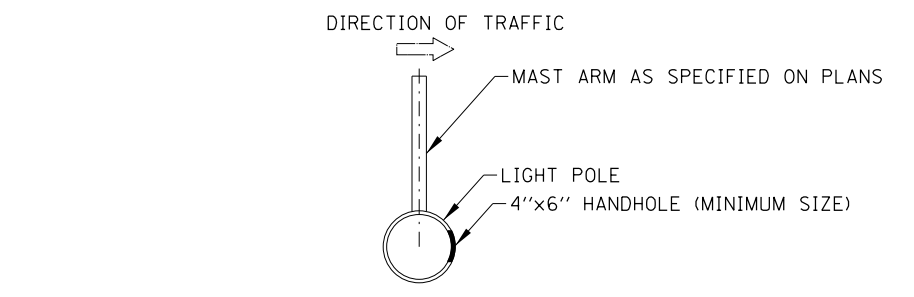
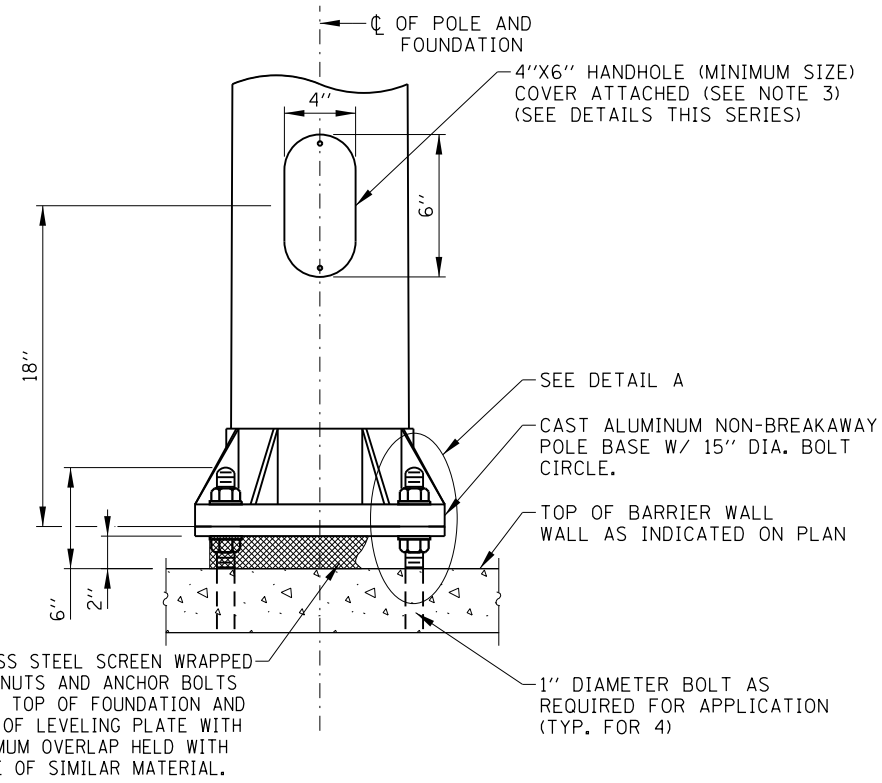
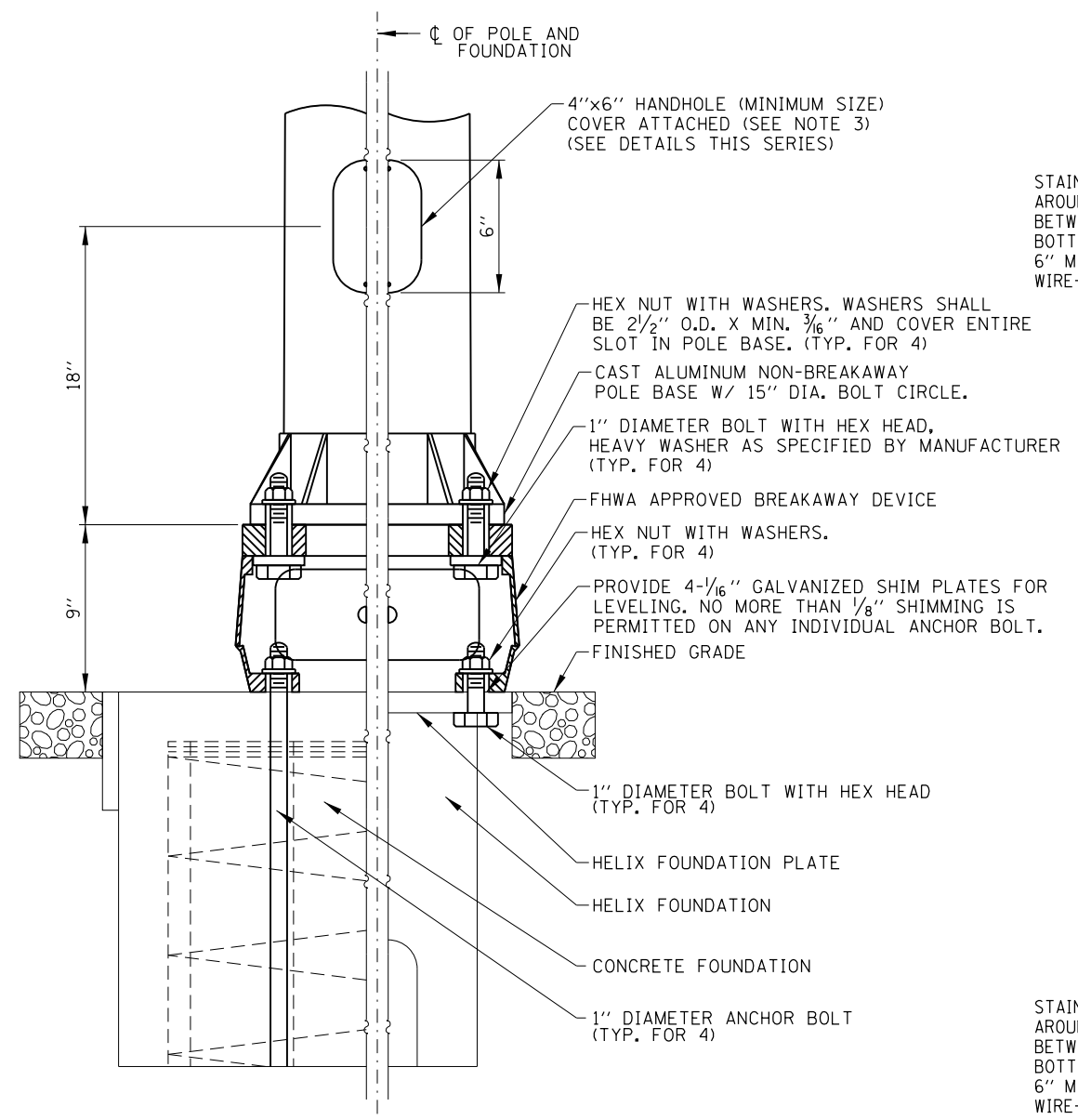
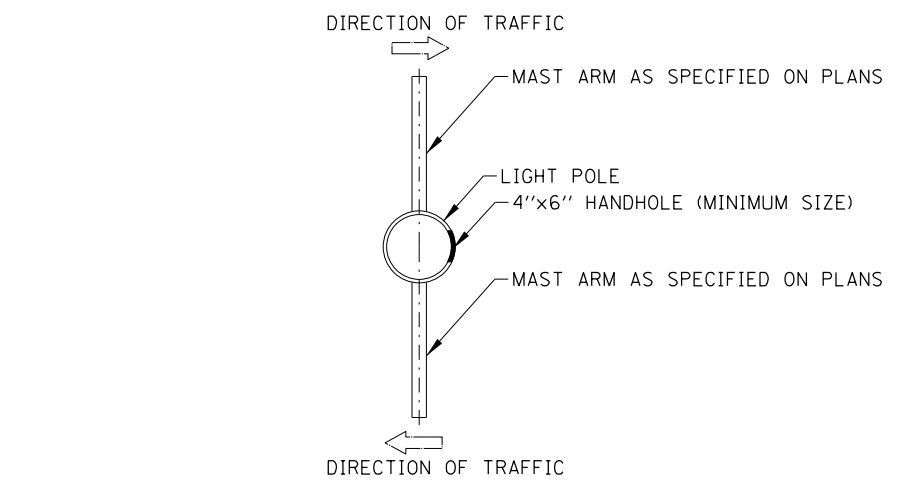
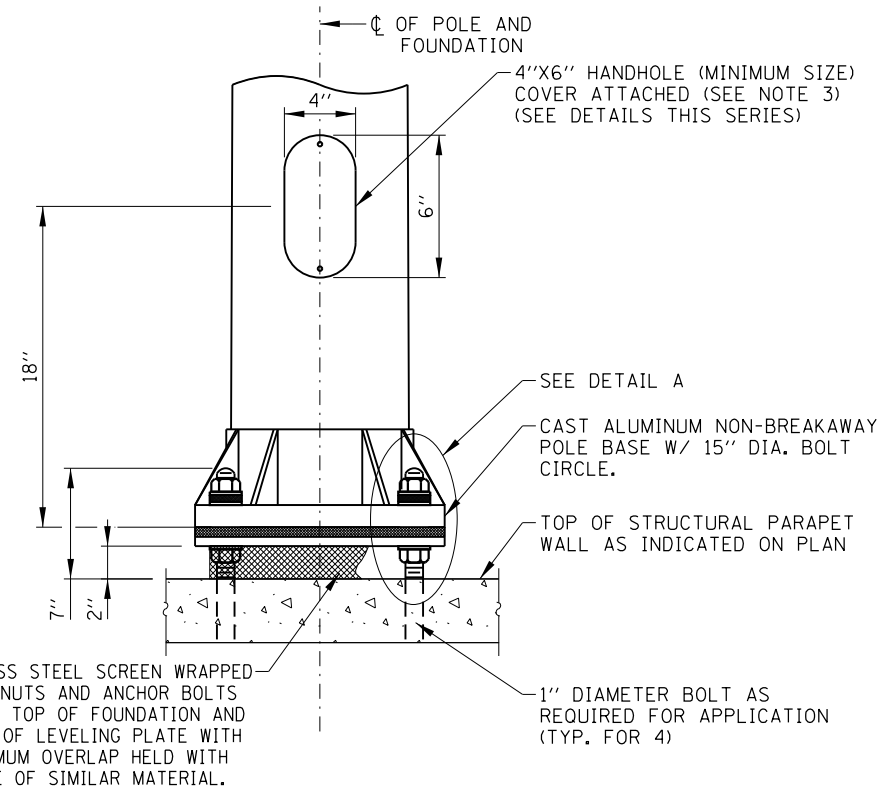
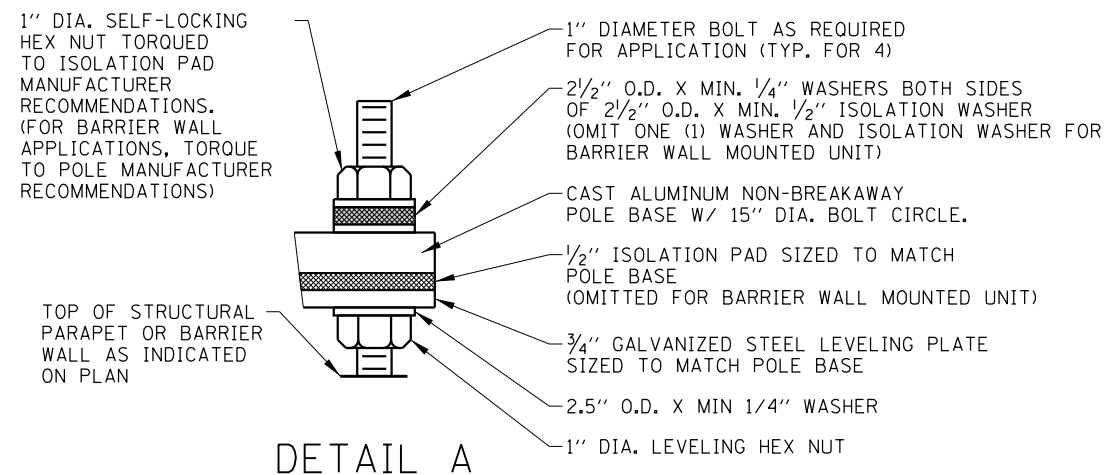

**LIGHT STANDARD HANDHOLE ORIENTATION DETAIL**

**LIGHT STANDARD MOUNTING DETAIL (GROUND MOUNTED UNITS)**

**LIGHT STANDARD MOUNTING DETAIL (BARRIER WALL MOUNTED UNITS)**

**LIGHT STANDARD MOUNTING DETAILS**

APPROVED: *Paul Kovacs* CHIEF ENGINEERING OFFICER DATE: 2-7-2012

NOTE: SEE SHEET 1 OF THIS SERIES FOR NOTES.

SHEET 2 OF 3

LIGHT STANDARD DETAILS

STANDARD H2-08

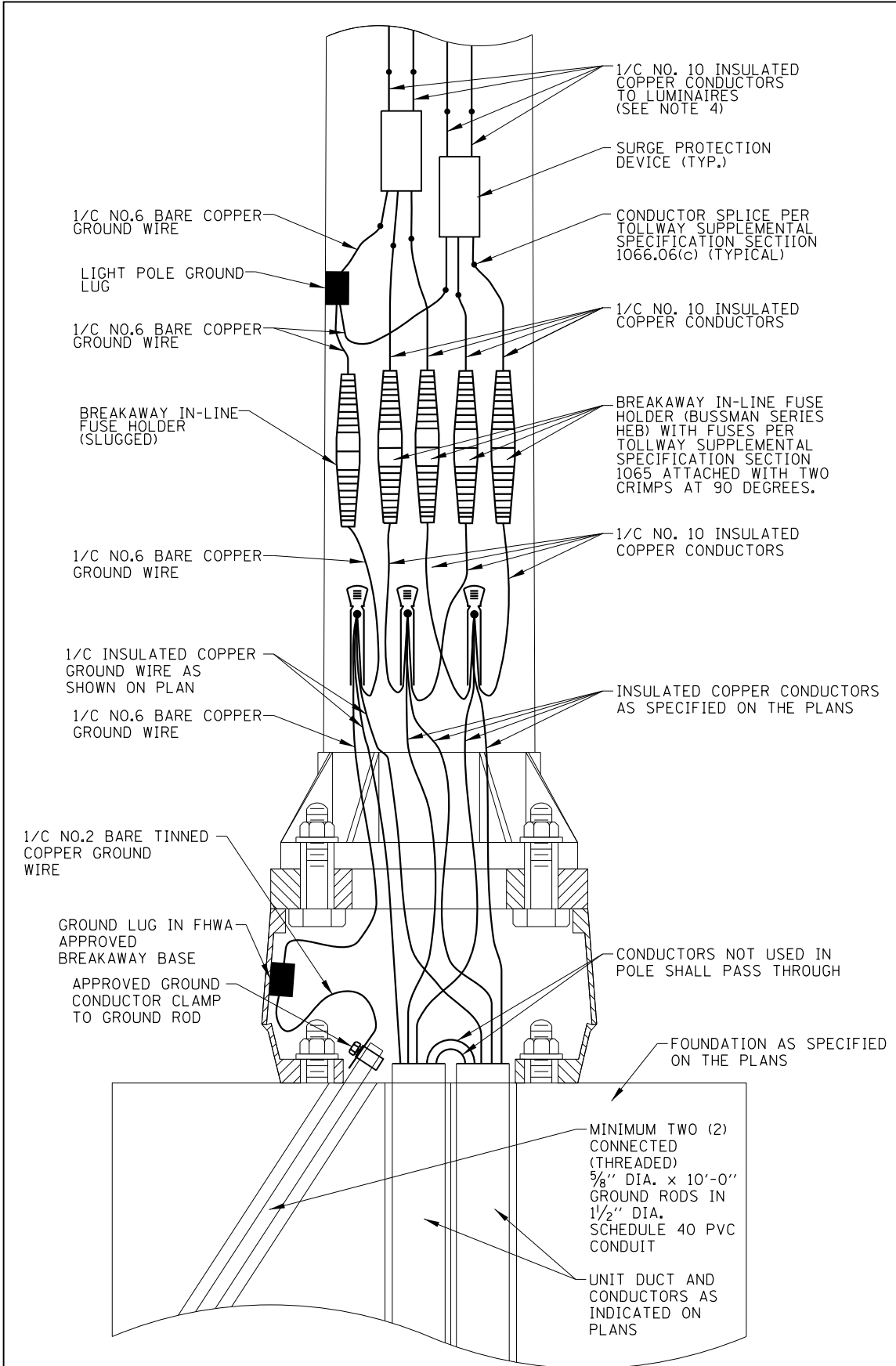

**LIGHT STANDARD WIRING DETAIL**  
**(GROUND MOUNTED UNITS)**  
 (SEE NOTES 7 & 8)

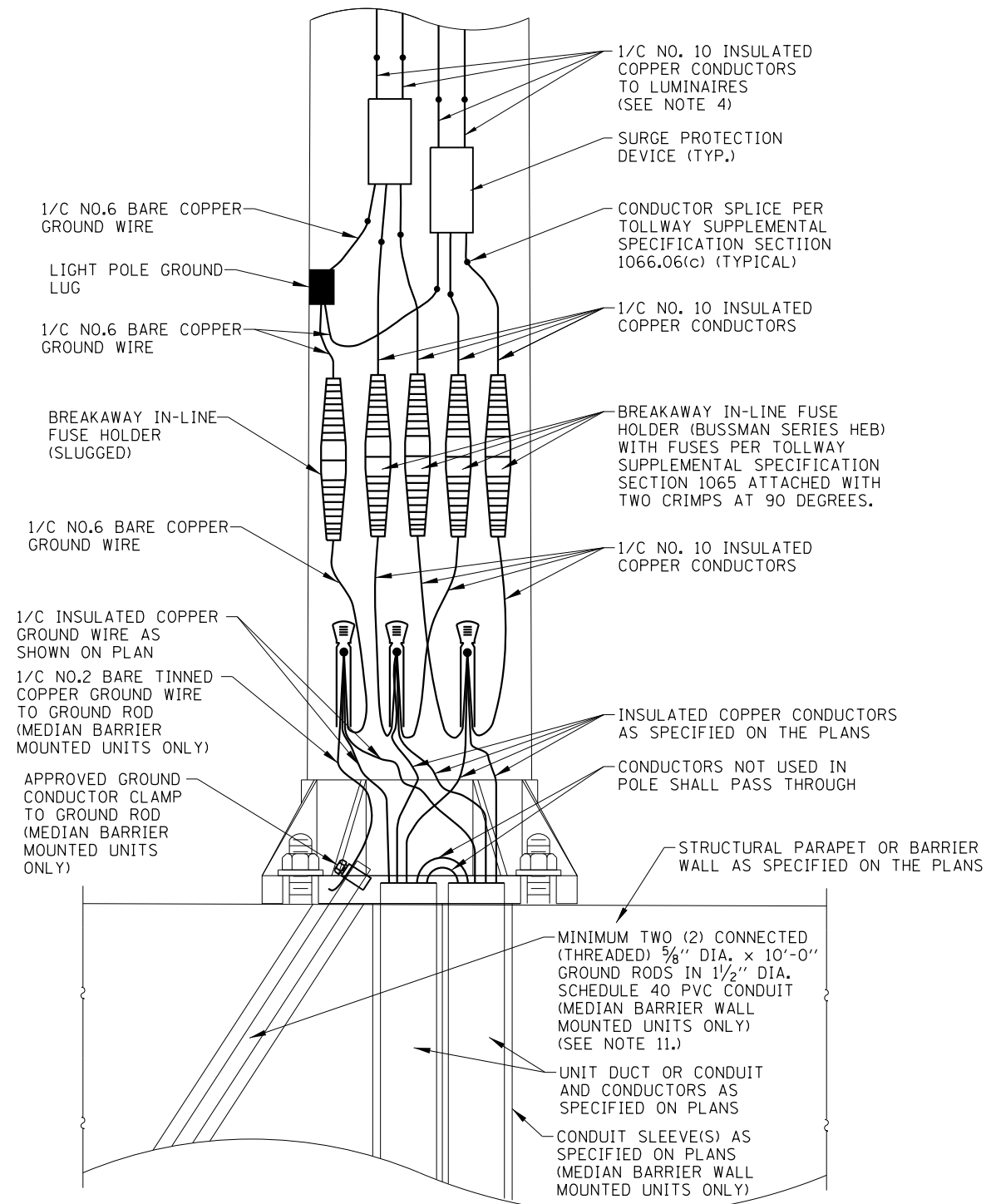

**LIGHT STANDARD WIRING DETAIL**  
**(STRUCTURAL AND BARRIER WALL MOUNTED UNITS)**

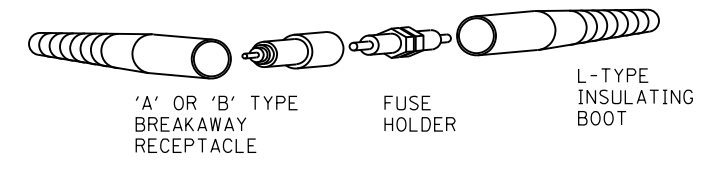

**IN-LINE FUSE HOLDER WITH BREAKAWAY FEATURE DETAIL**

*Paul Kovacs*  
 APPROVED, CHIEF ENGINEERING OFFICER  
 DATE 2-7-2012

**LIGHT STANDARD WIRING DETAILS**

**NOTE:**  
 SEE SHEET 1 OF THIS SERIES FOR NOTES.

SHEET 3 OF 3

LIGHT STANDARD DETAILS

STANDARD H2-08

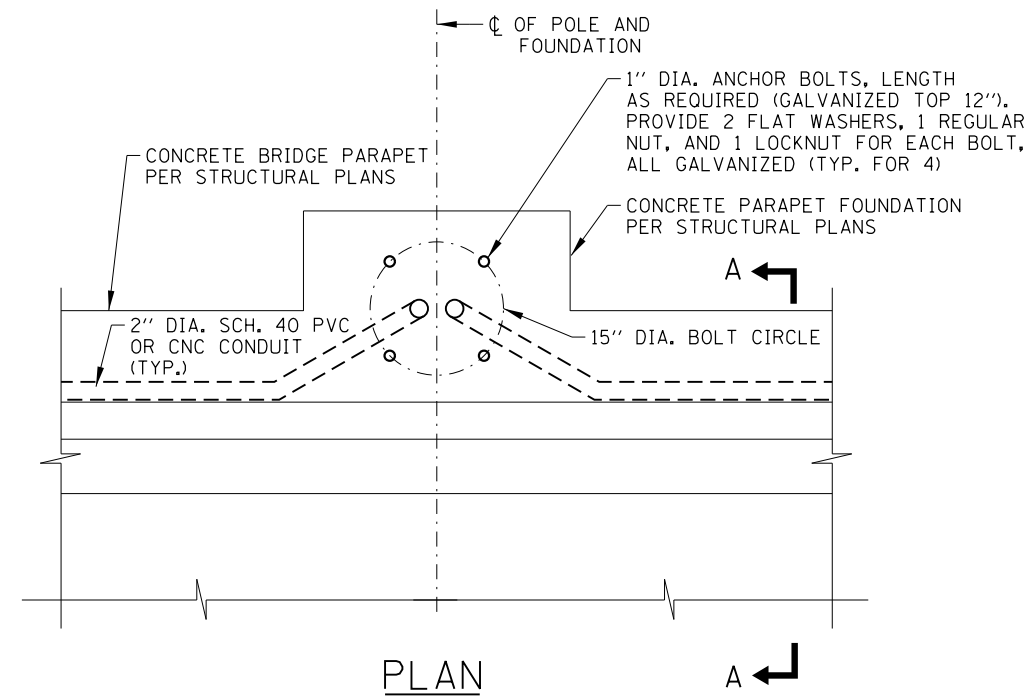

PLAN

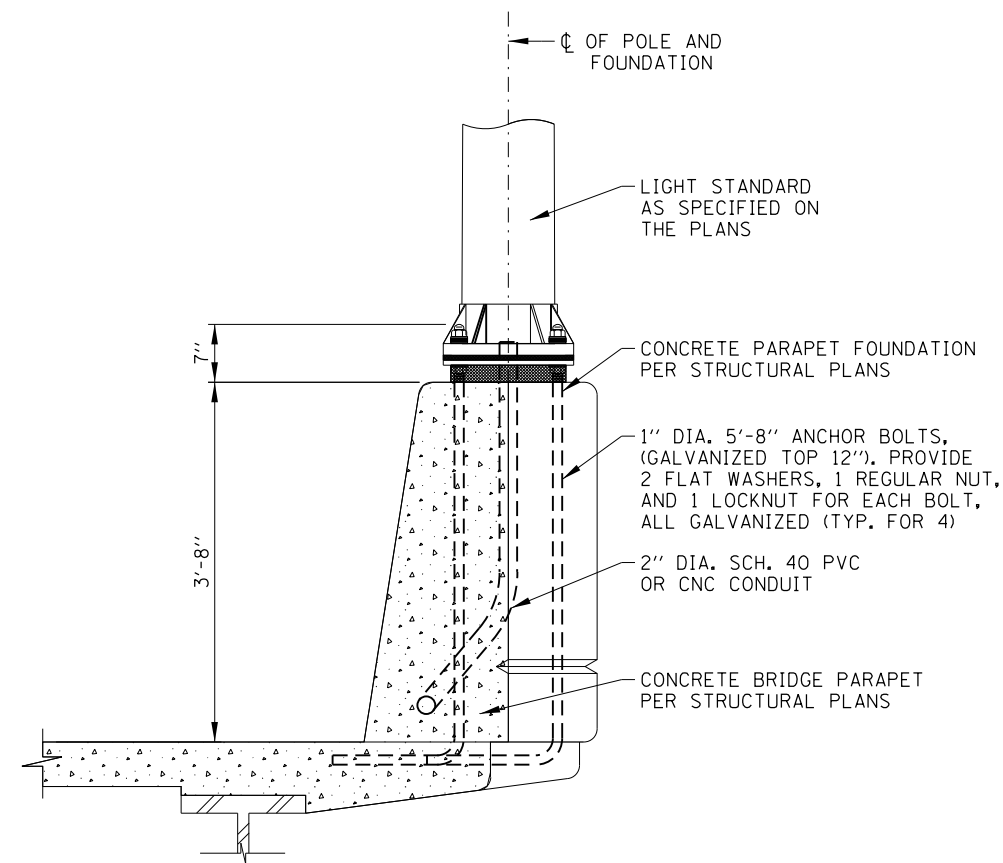

SECTION A-A

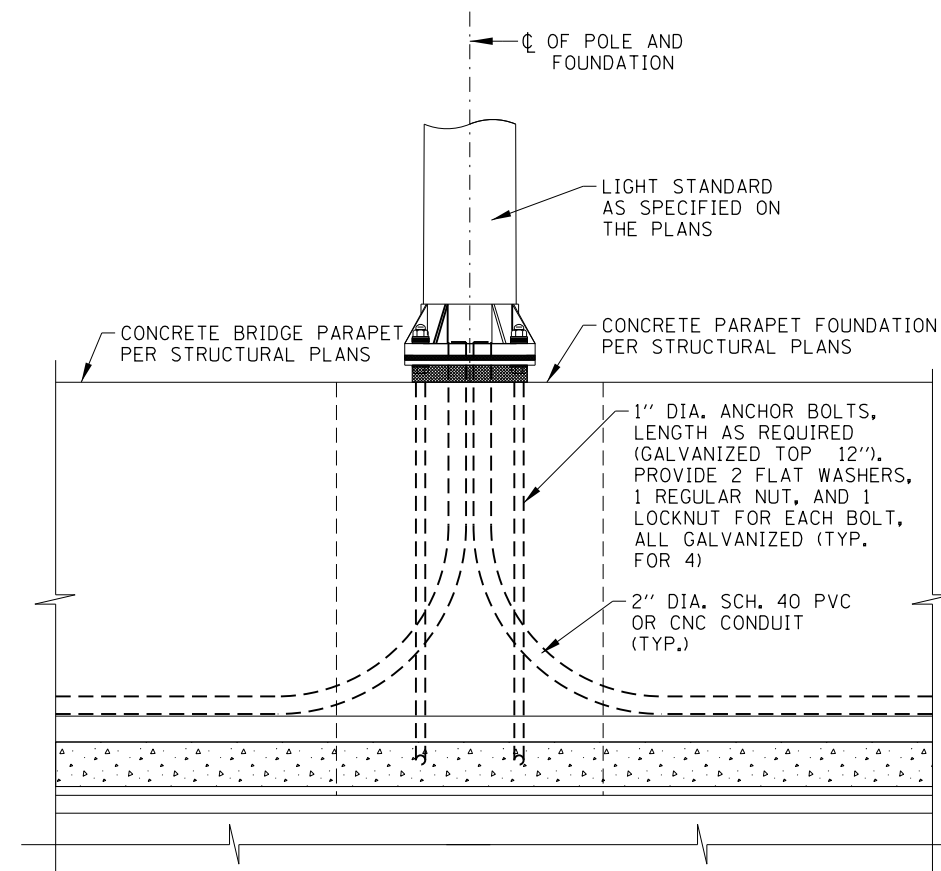

ELEVATION

**NOTES:**

1. FOR STRUCTURAL PARAPET FOUNDATION DETAILS, SEE STRUCTURAL PLANS.
2. THE END 4'-0" SECTION OF WINGWALL/PARAPET SHALL BE KEPT FREE FROM ANY ATTACHMENTS TO AVOID CONFLICT FROM TRAFFIC BARRIER TERMINAL.
3. ALL CONDUIT, JUNCTION BOXES AND APPURTENANCES MOUNTED TO STRUCTURE SHALL BE OFFSET FROM THE FACE OF THE STRUCTURE A MINIMUM OF ONE (1) INCH BY MEANS OF A STAINLESS STEEL C-CHANNEL. C-CHANNEL SHALL BE SECURED TO BRIDGE PARAPET WITH 1/2" DIA. EXPANSION ANCHORS (MIN. 2" LONG). EXPANSION ANCHORS SHALL BE HOT DIPPED GALVANIZED AFTER FABRICATION AND SHALL BE MADE BY PARABOLT, KWICK-BOLT OR WEJ-IT. CONDUIT SHALL BE SECURED WITH APPROVED CLAMPS A MINIMUM OF 5 FEET FROM CENTER AND A MINIMUM OF 2 FEET FROM ANY CHANGE IN DIRECTION OR JUNCTION BOX.
4. THE BARREL IN THE EXPANSION JOINT FITTING SHALL BE FULLY EMBEDDED IN THE CONCRETE ON ONE SIDE OF THE EXPANSION JOINT. ONE HALF THE LENGTH OF THE DEFLECTION FITTING SHALL BE EMBEDDED IN THE CONCRETE ON THE OTHER SIDE OF THE EXPANSION JOINT.
5. EXPANSION/DEFLECTION JOINTS SHALL BE PROVIDED AT ALL BRIDGE EXPANSION JOINTS.
6. ALL CLAMPS AND HARDWARE FOR CONDUIT MOUNTING SHALL BE OF LIKE MATERIAL AS THE CONDUIT.
7. ALL EQUIPMENT SHALL BE GROUNDED AND BONDED IN ACCORDANCE WITH THE NATIONAL ELECTRICAL CODE AND THE NATIONAL ELECTRICAL SAFETY CODE.

**CONDUIT EMBEDDED IN BRIDGE PARAPET**

APPROVED: *Paul Kovacs*  
CHIEF ENGINEERING OFFICER DATE: 2-7-2012.



BRIDGE  
CONDUIT DETAILS

STANDARD H3-06

DATE	REVISIONS
11-01-2012	REVISED JUNCTION BOX
3-11-2015	ADDED BRIDGE CONDUIT DETAILS
3-31-2017	REVISED NOTES
	REVISED APPROACH PARAPET CLEAR AREA DIM.
3-01-2018	TYPOGRAPHICAL CORRECTIONS.
3-01-2019	REVISED TO SHOW SINGLE SLOPE BARRIER.

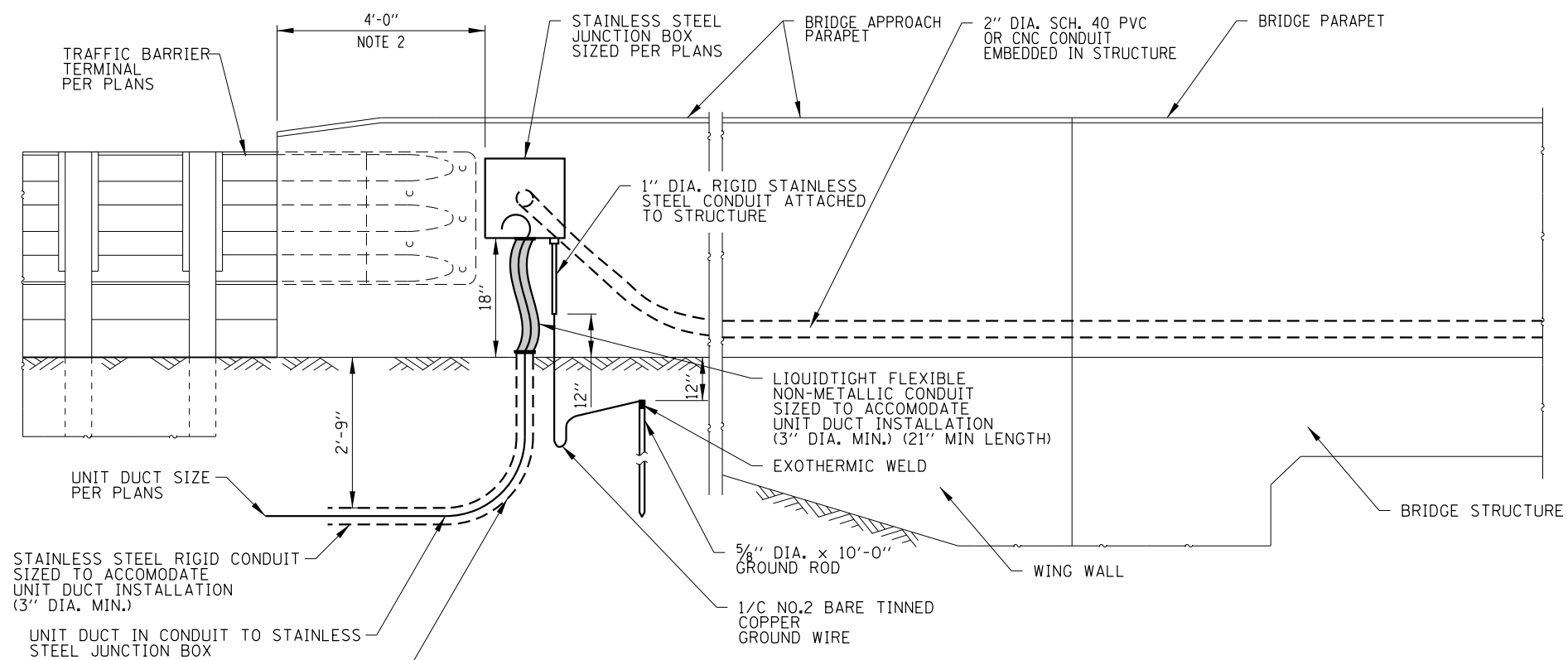

**CONDUIT EMBEDDED IN BRIDGE PARAPET WALLS  
(INTEGRAL/SEMI-INTEGRAL ABUTMENT WITH PARAPET ON APPROACH PAVEMENT)**

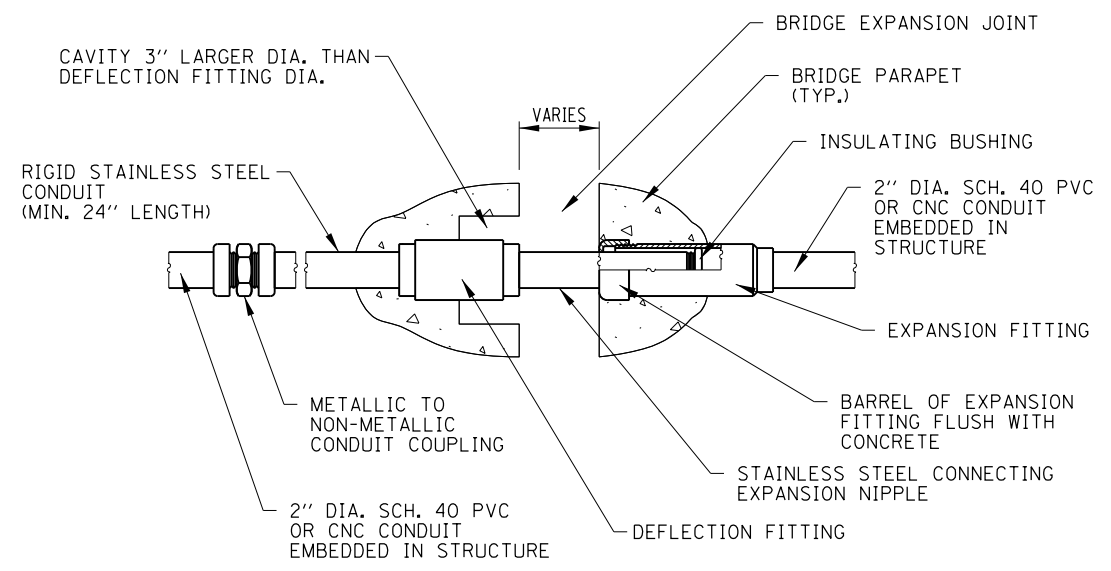

**COMBINATION EXPANSION/ DEFLECTION FITTING  
(SEE NOTES 4 & 5)**

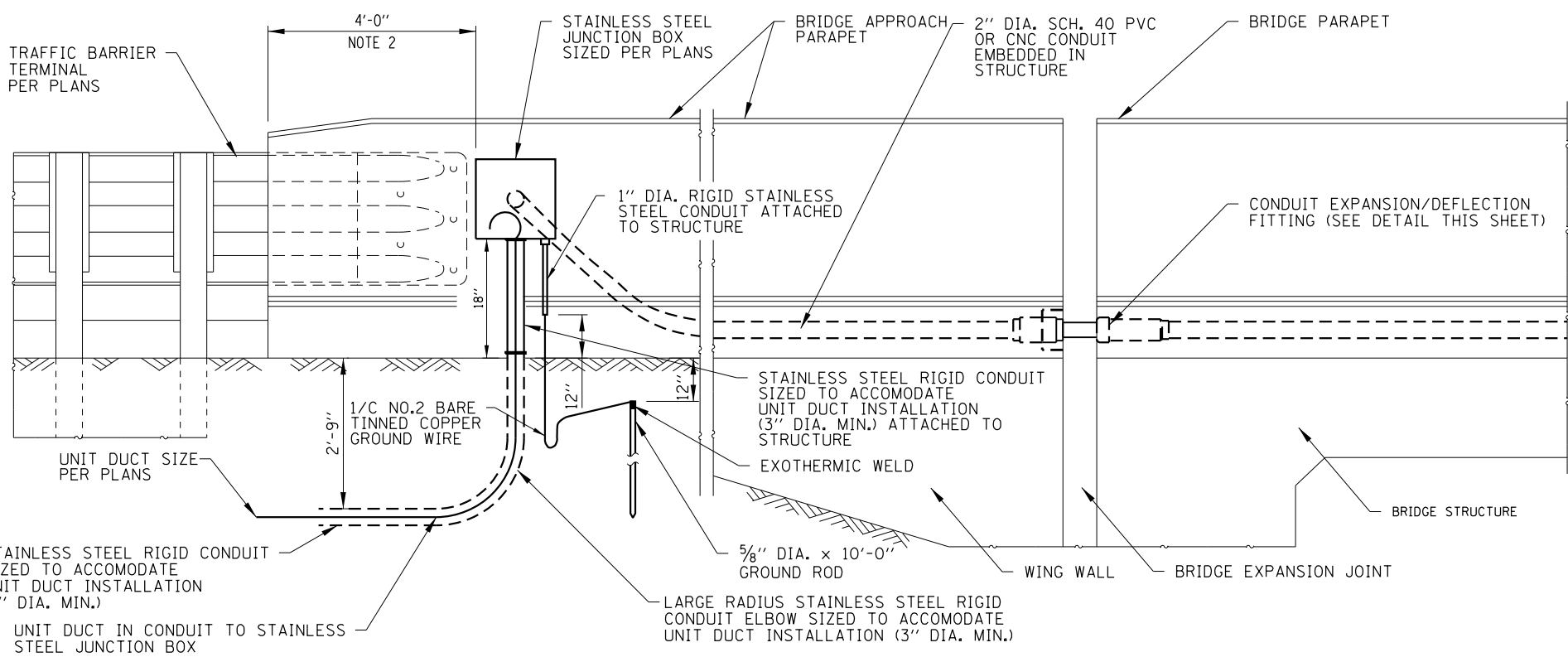

**CONDUIT EMBEDDED IN BRIDGE PARAPET WALLS  
(JOINTED ABUTMENT WITH PARAPET ON APPROACH PAVEMENT)**

APPROVED: *Paul Kovacs*  
CHIEF ENGINEERING OFFICER DATE: 2-7-2012

**NOTE:**  
SEE SHEET 1 OF THIS SERIES FOR NOTES.

SHEET 2 OF 4



BRIDGE  
CONDUIT DETAILS

STANDARD H3-06



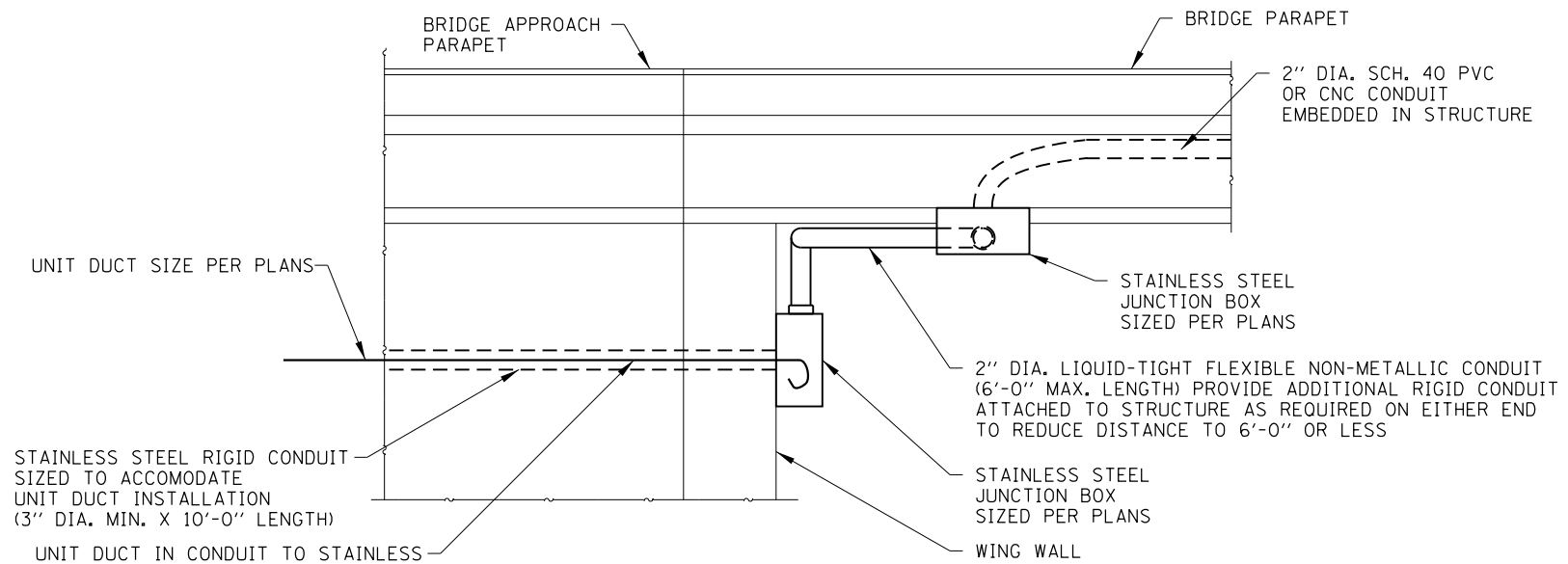

PLAN

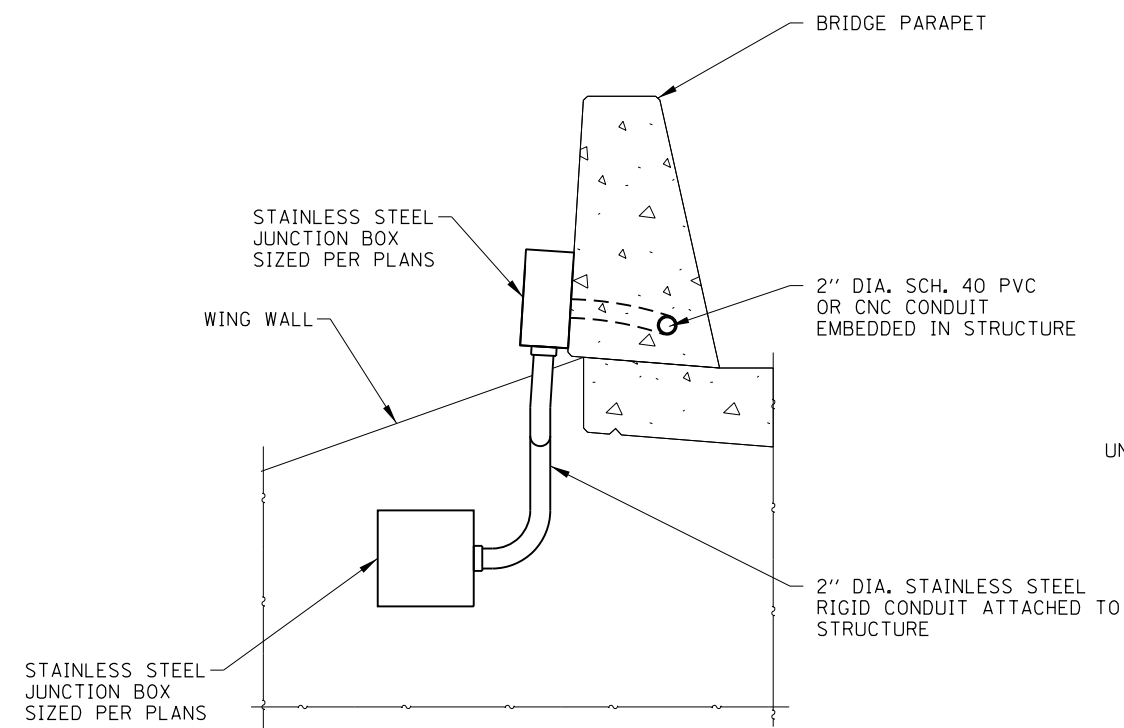

SECTION A-A

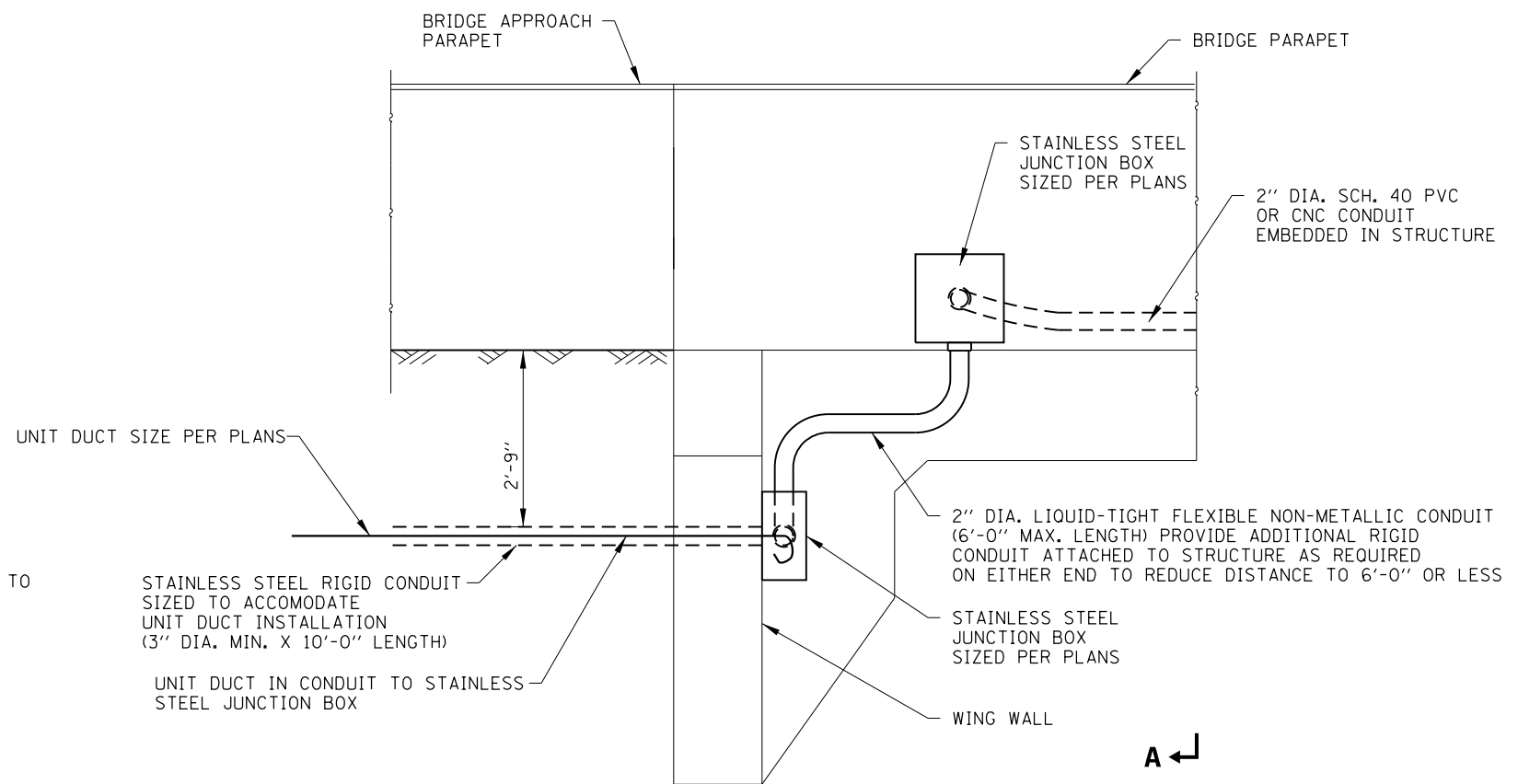

ELEVATION

NOTE:  
SEE SHEET 1 OF THIS SERIES FOR NOTES.



BRIDGE  
CONDUIT DETAILS

STANDARD H3-06

APPROVED: *Paul Kovacs*  
CHIEF ENGINEERING OFFICER DATE: 2-7-2012.

CONDUIT EMBEDDED IN BRIDGE PARAPET WALLS  
(INTEGRAL/SEMI-INTEGRAL ABUTMENT WITH PARAPET ENDING ON BRIDGE DECK)

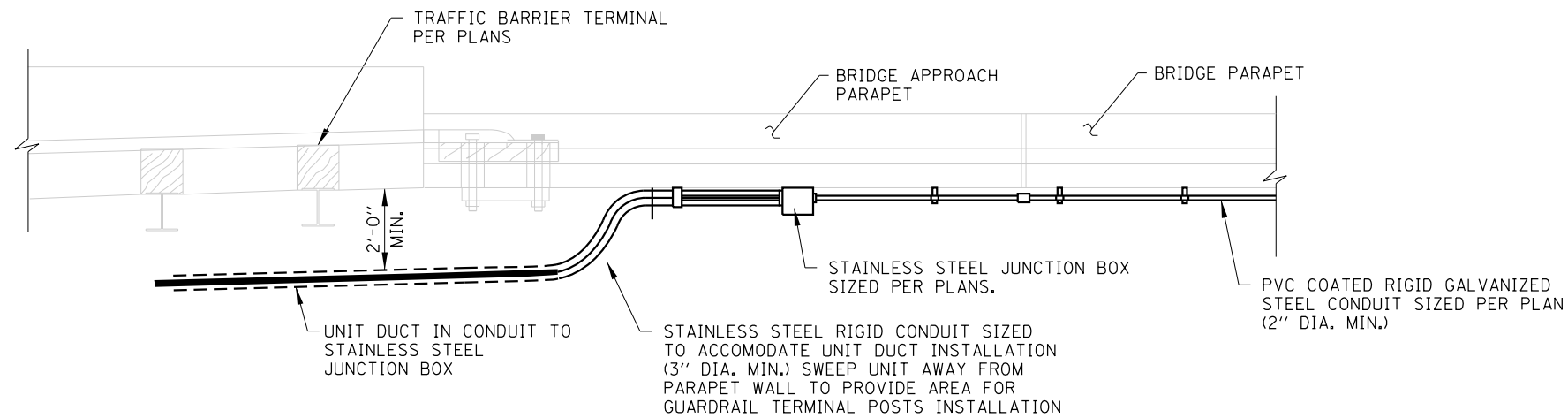

PLAN VIEW

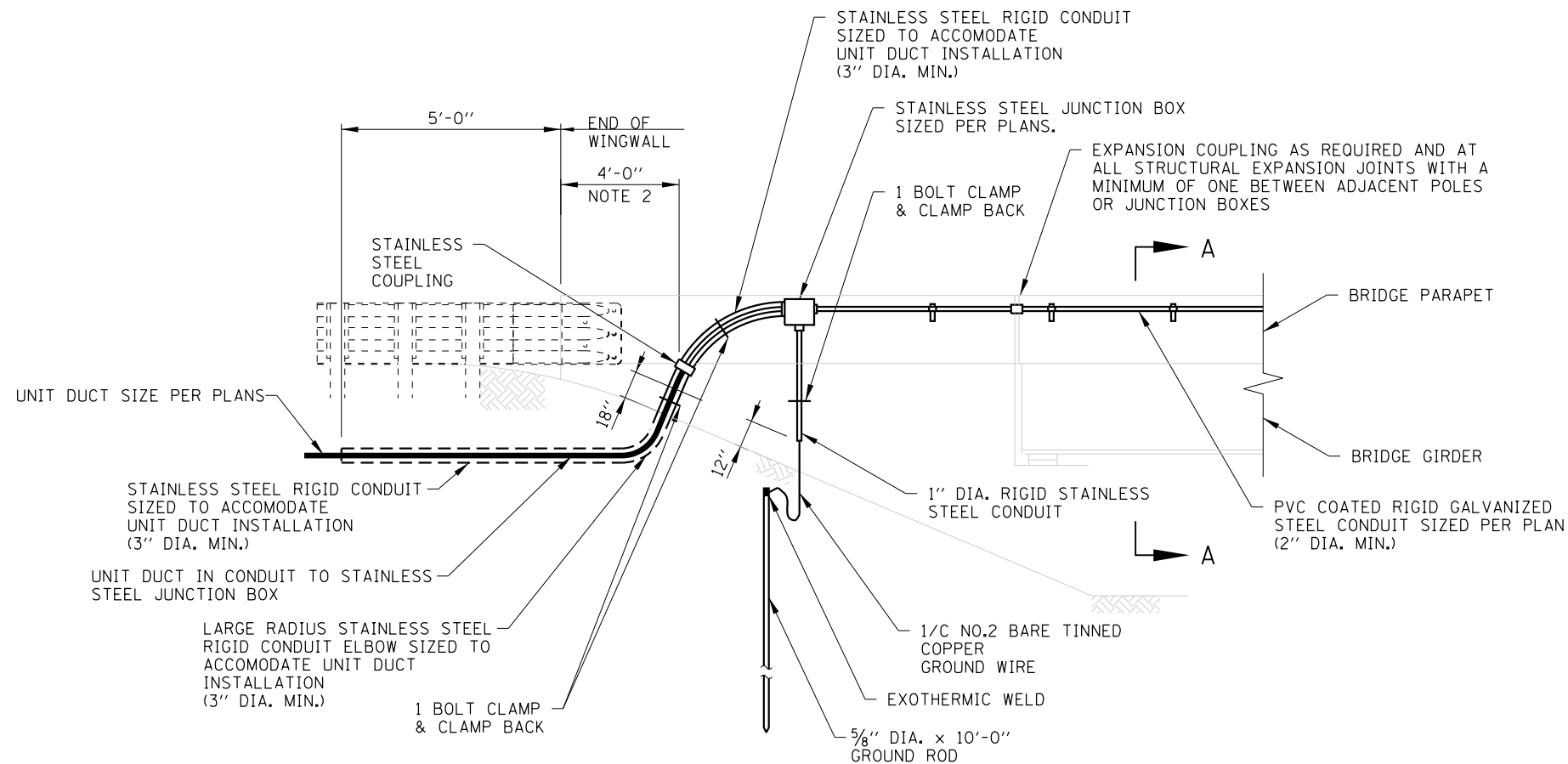

ELEVATION OF TYPICAL WINGWALL CONDUIT TRANSITION

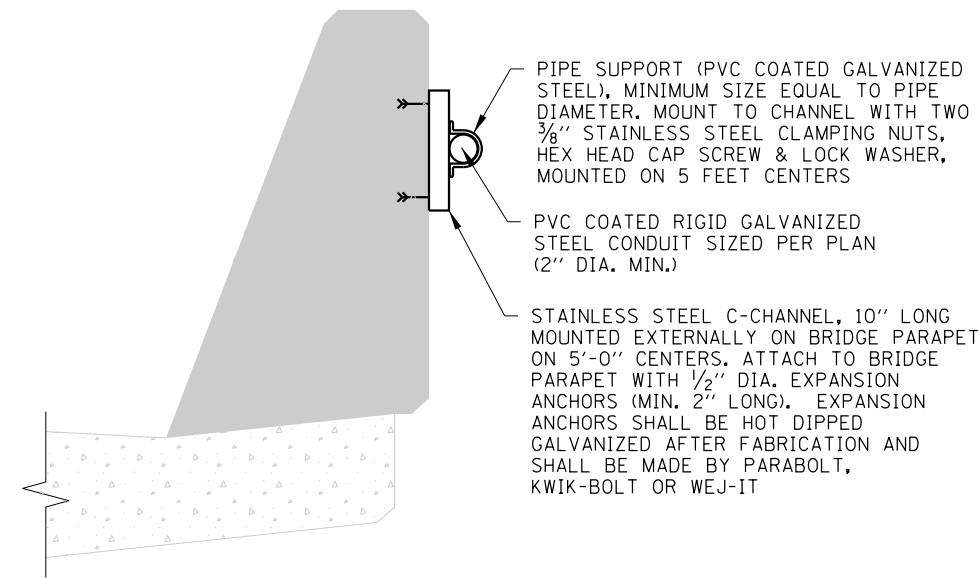

SECTION A-A

CONDUIT ATTACHED TO BRIDGE PARAPET

APPROVED. *Paul Kovacs* CHIEF ENGINEERING OFFICER DATE 2-7-2012.

NOTE: SEE SHEET 1 OF THIS SERIES FOR NOTES.

SHEET 4 OF 4

BRIDGE CONDUIT DETAILS

STANDARD H3-06

DIRECTION OF TRAFFIC

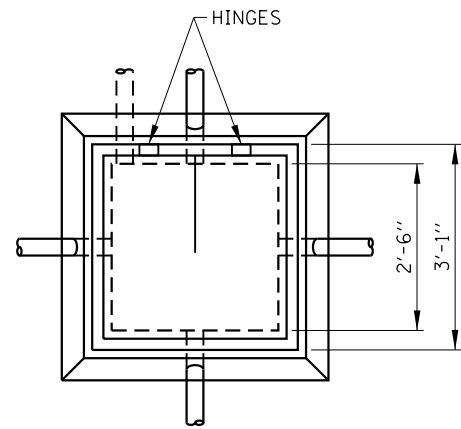

PLAN



EAST JORDAN  
EJ 8216



NEENAH  
R-6662-PS

**NOTES:**

1. HEAVY-DUTY HANDHOLE LOCATED IN UNPAVED AREAS AND NOT SHIELDED BY GUARDRAIL SHALL BE CONSTRUCTED WITH THE TOP FLUSH WITH THE ADJACENT SLOPE.
2. HEAVY-DUTY HANDHOLE SHALL BE CONSTRUCTED IN NON-PAVED AREAS. THE FRAME AND HINGED COVER SHALL BE EITHER NEENAH FOUNDRY R-6662-PS WITH TYPE G LIFTING HANDLE OR EAST JORDAN IRON WORKS EJ 8216 WITH MPIC OR APPROVED EQUAL. THE HINGED COVER SHALL BE PROVIDED WITH A LIFT ASSIST MECHANISM. THERE SHALL BE TWO SETS OF HINGES AND THE DESIGN SHALL ALLOW FOR THE COVER TO OPEN > 90 DEGREES. THE COVER SHALL BE PROVIDED WITH A HOLD OPEN SAFETY ARM THAT CATCHES TO PREVENT ACCIDENTAL CLOSURE. THE COVER SHALL ALSO BE ABLE TO BE MADE FULLY REMOVABLE. THE FRAME COVER SHALL BE INSTALLED WITH THE HINGES TO THE SIDE FACING APPROACHING TRAFFIC.
3. AGGREGATE FOR FRENCH DRAIN SHALL BE PER ARTICLE 1003.04 OF THE STANDARD SPECIFICATIONS.
4. 10 FEET OF EXTRA CABLE SHALL BE COILED IN EACH HANDHOLE.
5. ALL METALLIC COMPONENTS OF THE HANDHOLE SHALL BE GROUNDED AND BONDED IN ACCORDANCE WITH THE ILLINOIS TOLLWAY SUPPLEMENTAL SPECIFICATIONS SECTION 814, THE NATIONAL ELECTRICAL CODE AND THE NATIONAL ELECTRICAL SAFETY CODE.
6. THE HANDHOLE COVER SHALL BE LETTERED "ELECTRIC". LETTERING SHALL BE 2" FLAT FACE GOTHIC AND BE FLUSH WITH THE SLIP RESISTANT SURFACE.

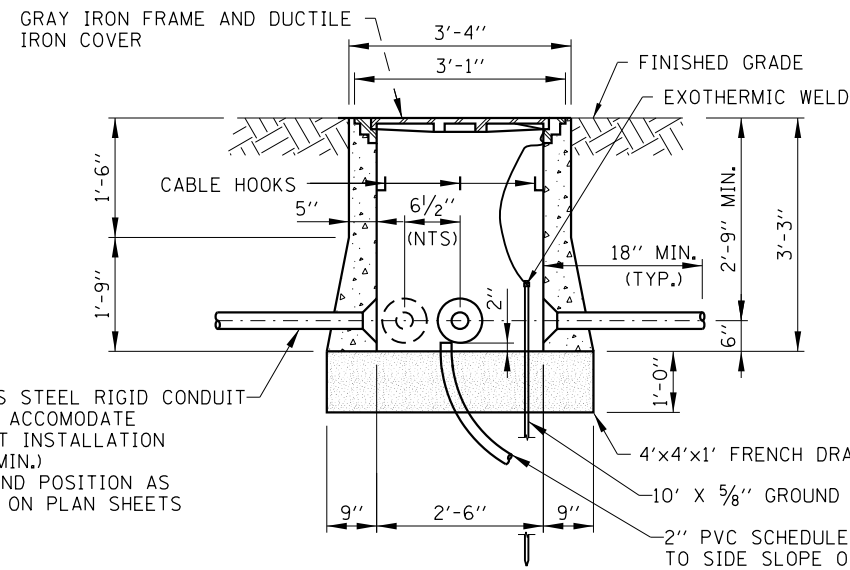

ELEVATION

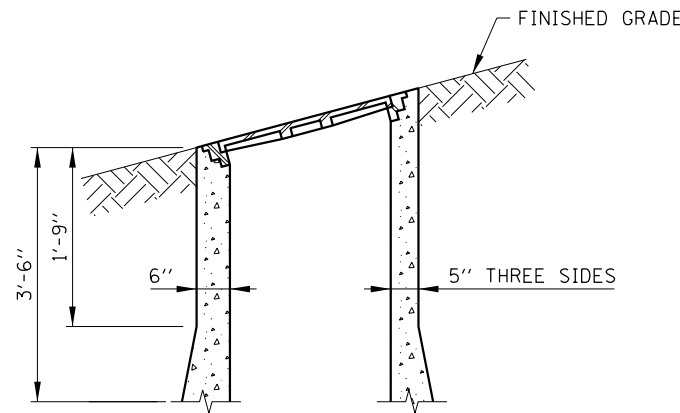

SLOPE INSTALLATION

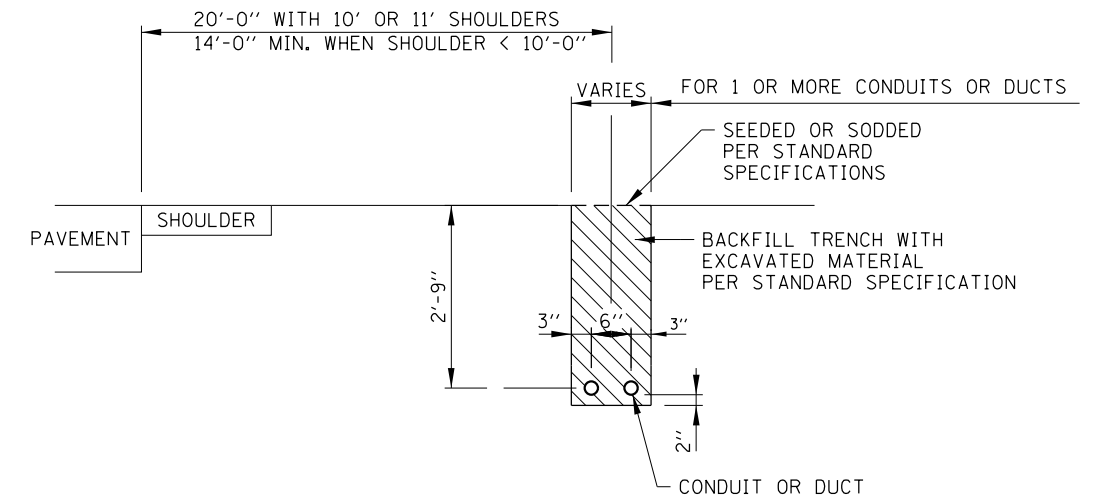

TRENCHING FOR CONDUIT IN NON-PAVED AREAS

HEAVY-DUTY HANDHOLE DETAILS

*Paul Kovacs*  
APPROVED..... CHIEF ENGINEER..... DATE 2-7-2012

DATE	REVISIONS
3-11-2015	DELETED NON HEAVY-DUTY HANDHOLE.
3-31-2016	NEW HINGED COVER AND REVISED NOTES.
3-31-2017	REVISED NOTES.
	REMOVED GROUND ROD FROM DETAIL.
3-1-2021	REMOVED SAND FROM CONDUIT TRENCH. GROUND ROD SHOWN IN ELEVATION VIEW.

**Illinois Tollway**

HEAVY-DUTY HANDHOLE AND BURIED WIRING DETAILS

STANDARD H4-05

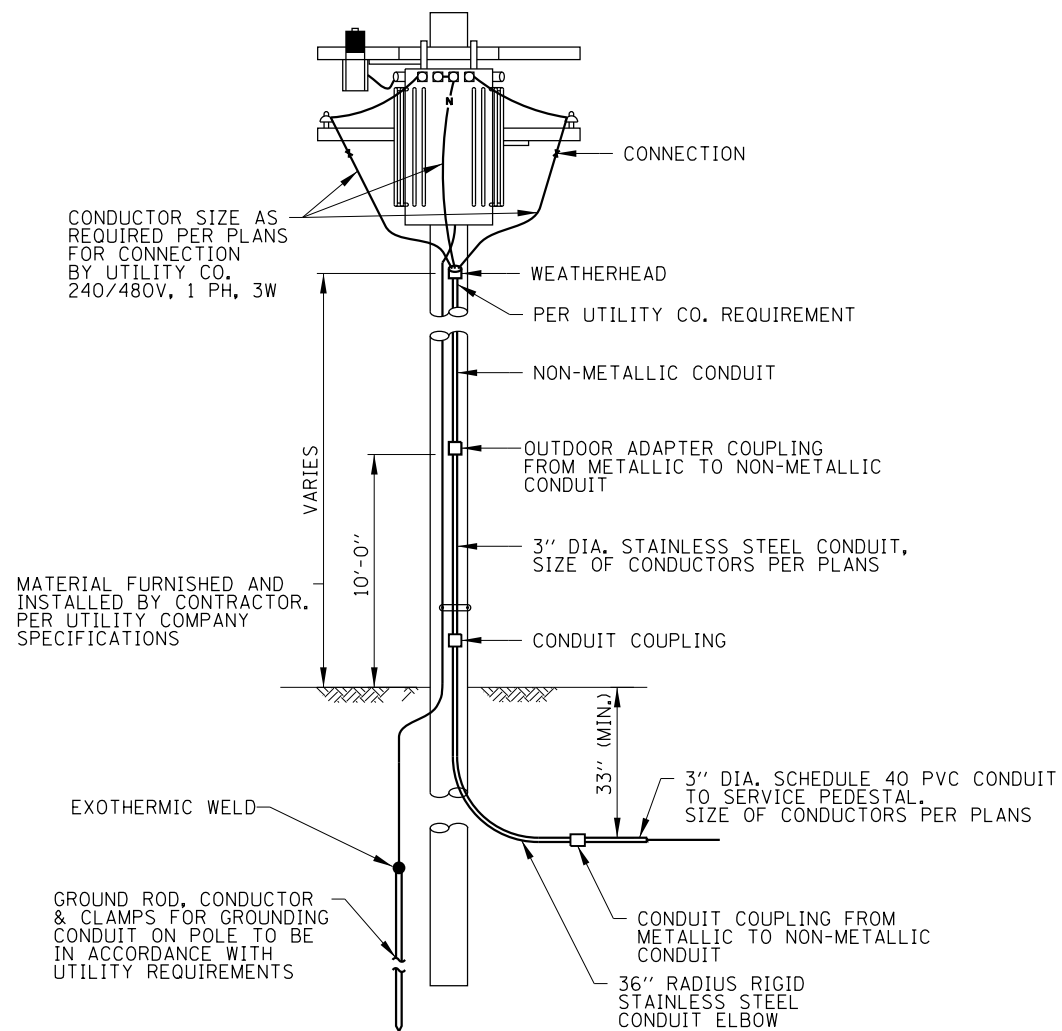

### UTILITY SERVICE POLE

SUBJECT TO UTILITY COMPANY APPROVAL

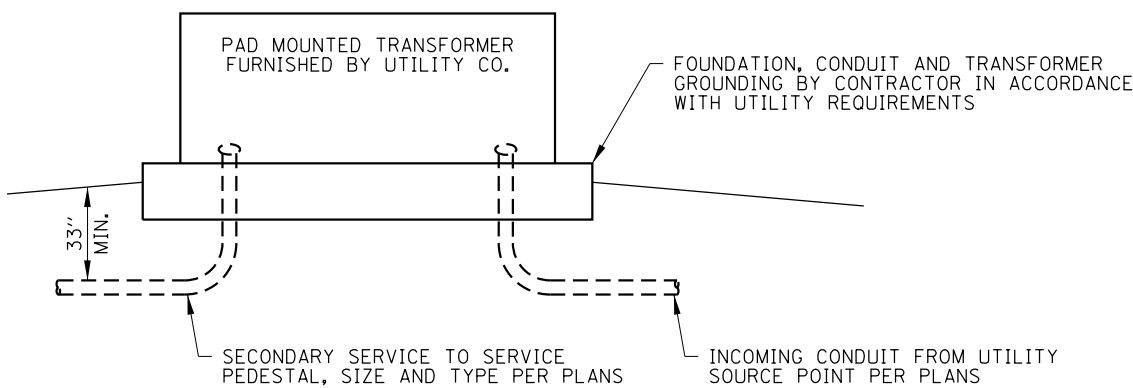

### UTILITY PAD MOUNTED TRANSFORMER

SUBJECT TO UTILITY COMPANY APPROVAL

#### NOTES:

- METER HOUSING SHALL BE MOUNTED TO BACK WALL OF CONTROL CABINET. PROVIDE A GATE IN R.O.W. FENCE TO ALLOW UTILITY ACCESS TO READ THE METER.
- CABLES FROM METER HOUSING SHALL PASS THROUGH BACK WALL OF CONTROL CABINET.
- CONTRACTOR MUST COORDINATE WITH PEDESTAL BASE SUPPLIER AND FURNISH THE NECESSARY ANCHOR RODS.
- PROVIDE A 2 1/2" CONDUIT HUB, 2 1/2" NIPPLE AND 2 1/2" TO 3" CONDUIT REDUCER FITTING.
- ALL EQUIPMENT SHALL BE GROUNDING AND BONDED IN ACCORDANCE WITH THE NATIONAL ELECTRICAL CODE AND THE NATIONAL ELECTRICAL SAFETY CODE.

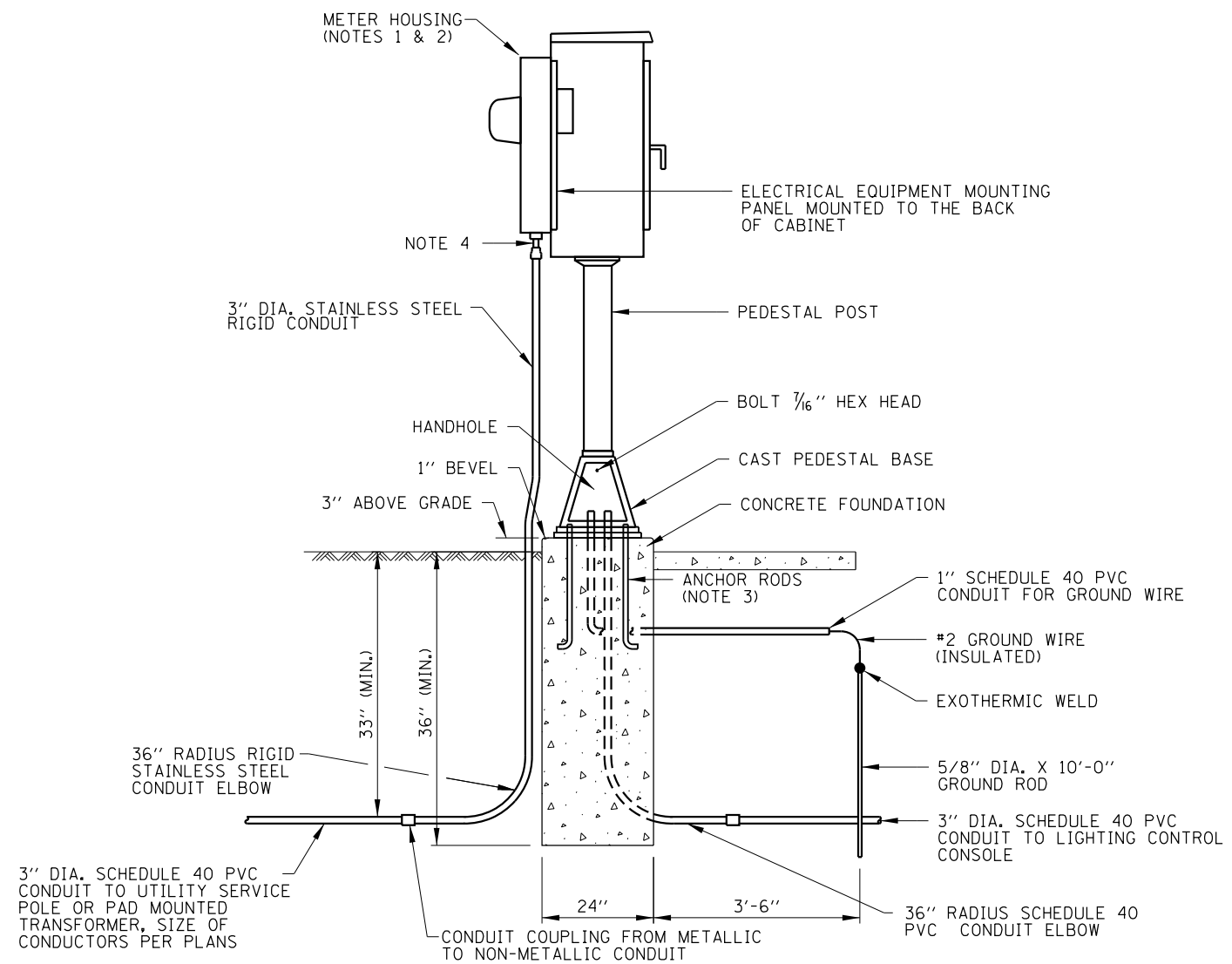

### SERVICE PEDESTAL WITH METER DETAIL



DATE	REVISIONS
3-31-2016	REVISED CONDUIT DEPTH.
3-31-2017	ADDED EQUIPMENT LAYOUTS
3-1-2018	TYPOGRAPHICAL CORRECTIONS.
3-1-2021	ADDED COMBINED LIGHTING/ITS PEDESTAL.

SERVICE POLE AND PEDESTAL DETAILS

STANDARD H5-06

APPROVED: *Paul Kovacs*  
 CHIEF ENGINEERING OFFICER DATE: 2-7-2012.

**ITEM DESCRIPTION**

- ① POWER DISTRIBUTION/TERMINAL BLOCK, WITH INGRESS PROTECTION RATING IP20.
- ② SURGE PROTECTION DEVICE
- ③ CIRCUIT BREAKER, 200 AMPERE, 2-POLE, 600 VOLT RATED
- ④ GROUNDING AND/OR NEUTRAL BUS
- ⑤ CIRCUIT BREAKER, 30 AMPERE (OR AS REQUIRED BY CONTRACT PLANS), 2-POLE, 600 VOLT RATED
- ⑥ CIRCUIT BREAKER, 30 AMPERE, 2-POLE, 600 VOLT RATED

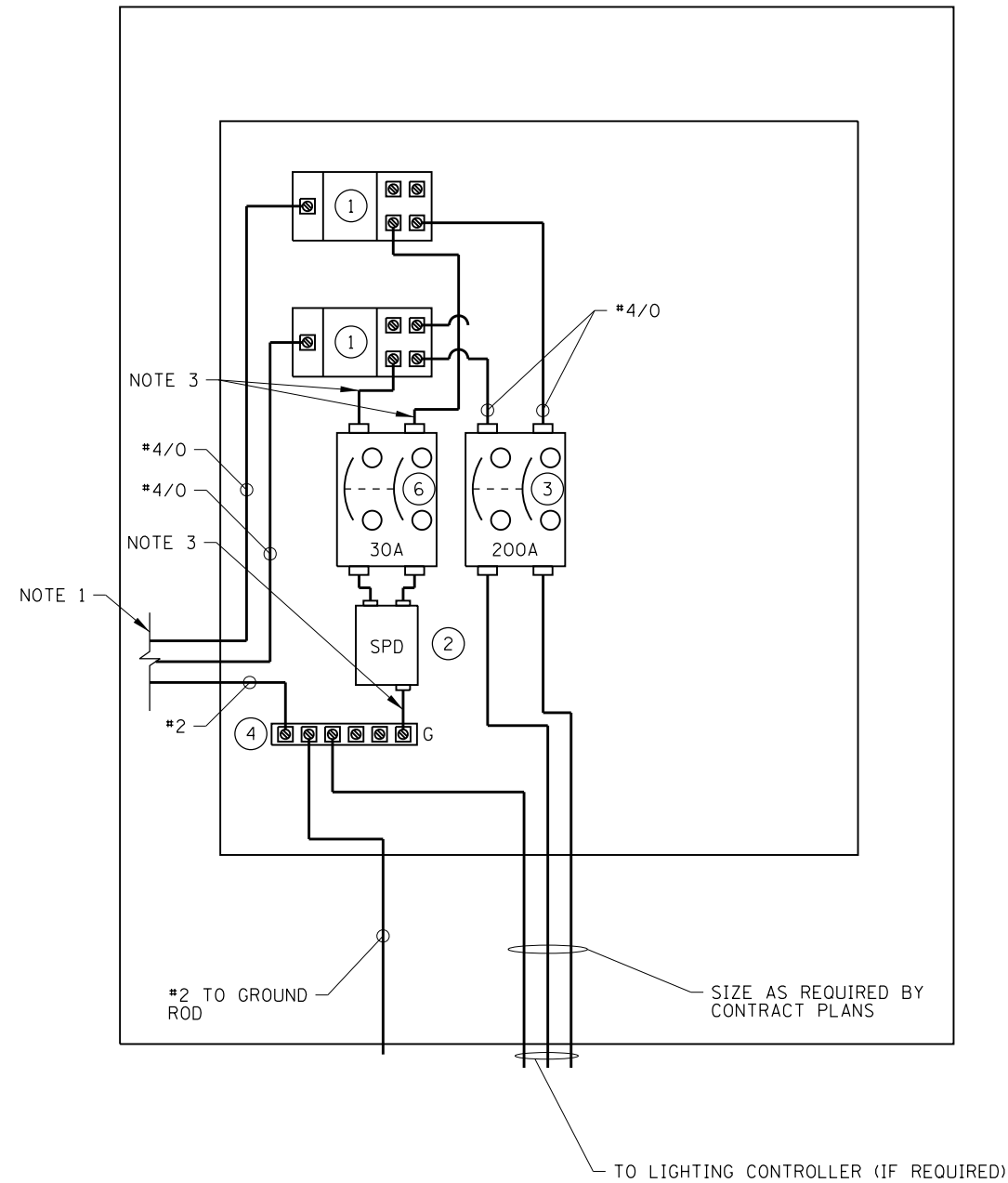

**SERVICE PEDESTAL INTERIOR ELECTRIC EQUIPMENT LAYOUT & WIRING DIAGRAM**

ROADWAY LIGHTING

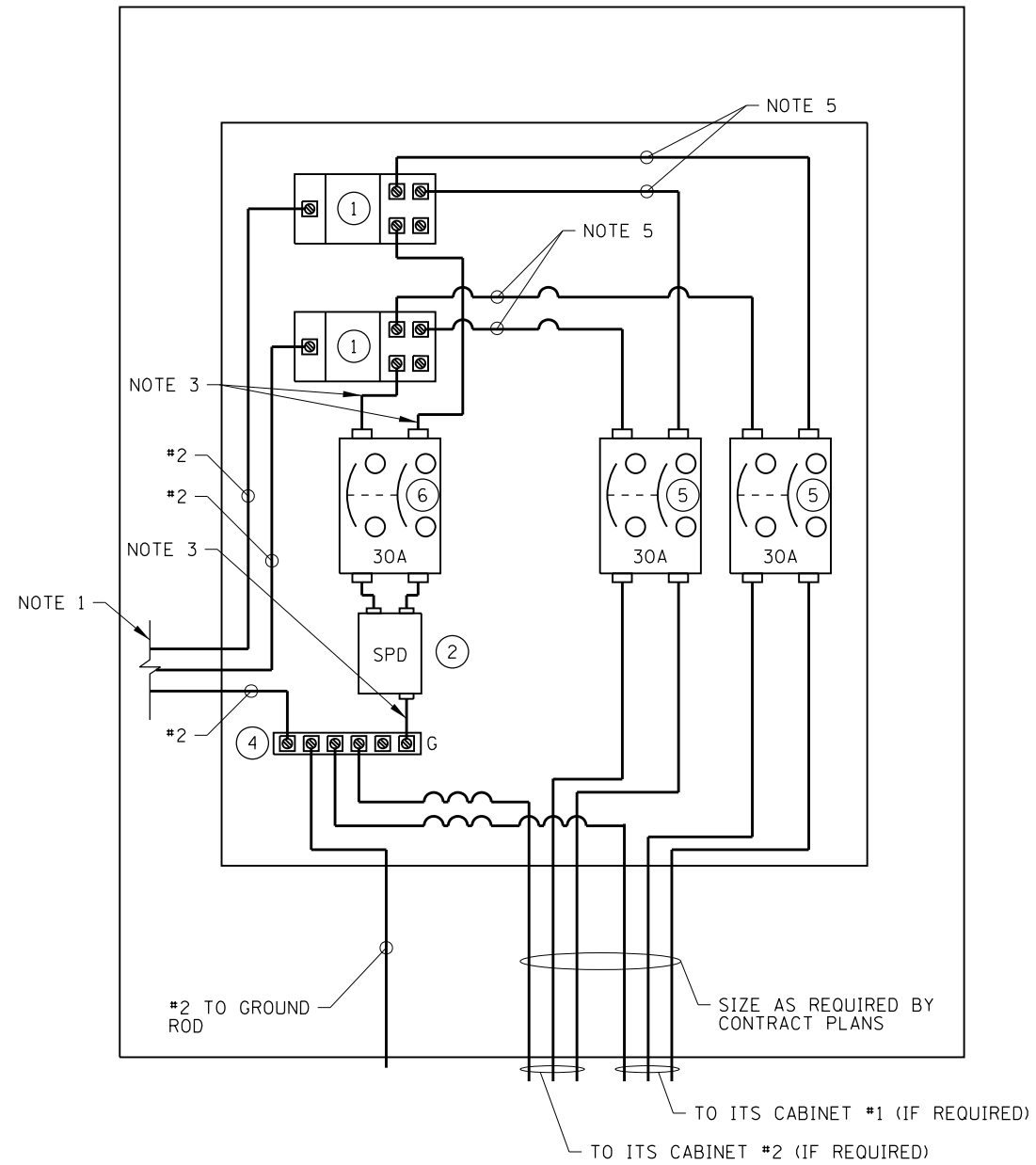

**SERVICE PEDESTAL INTERIOR ELECTRIC EQUIPMENT LAYOUT & WIRING DIAGRAM**

ROADWAY ITS

**NOTES:**

1. ELECTRIC SERVICE CONDUCTORS FROM METER HOUSING.
2. ELECTRIC SERVICE CONDUCTORS TO LIGHTING CONTROL CONSOLE. SIZE AS INDICATED ON THE PLANS.
3. SURGE PROTECTION DEVICE CONDUCTORS SIZE SHALL BE ACCORDING TO MANUFACTURER'S RECOMMENDATION.
4. ELECTRIC CONDUCTORS SHOWN WITH MINIMUM SIZES. LARGER SIZES SHALL BE USED AS REQUIRED OR AS SHOWN ON THE PLANS.
5. CABLES SHALL BE MINIMUM #4 AWG OR AS REQUIRED FOR CIRCUIT BREAKER.



SERVICE POLE AND PEDESTAL DETAILS

STANDARD H5-06

APPROVED: *Paul Kovacs*  
CHIEF ENGINEERING OFFICER DATE: 2-7-2012.

**ITEM DESCRIPTION**

- ① POWER DISTRIBUTION/TERMINAL BLOCK, WITH INGRESS PROTECTION RATING IP20.
- ② SURGE PROTECTION DEVICE
- ③ CIRCUIT BREAKER, 200 AMPERE, 2-POLE, 600 VOLT RATED
- ④ GROUNDING AND/OR NEUTRAL BUS
- ⑤ CIRCUIT BREAKER, 30 AMPERE (OR AS REQUIRED BY CONTRACT PLANS), 2-POLE, 600 VOLT RATED
- ⑥ CIRCUIT BREAKER, 30 AMPERE, 2-POLE, 600 VOLT RATED

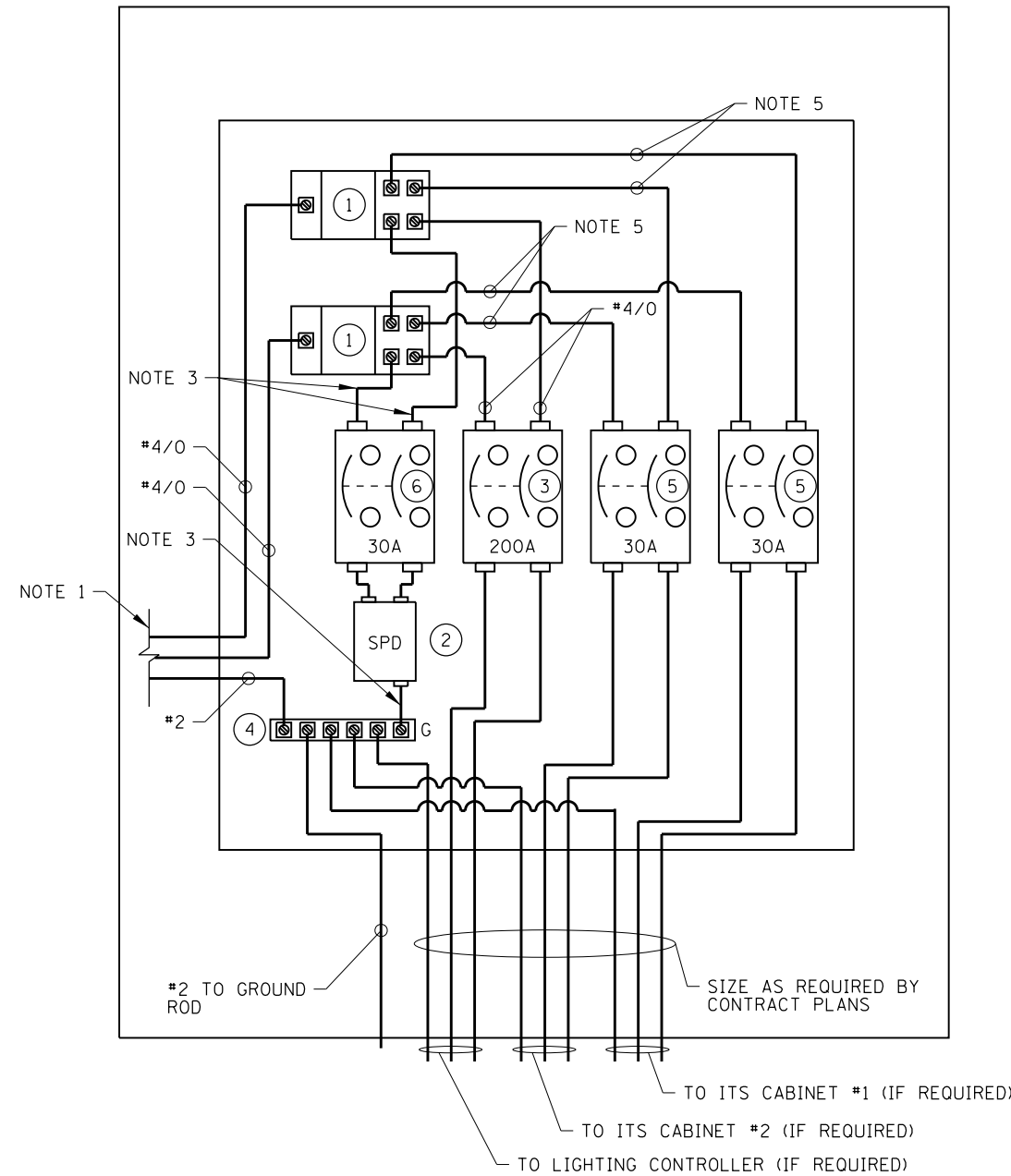

**SERVICE PEDESTAL INTERIOR ELECTRIC EQUIPMENT LAYOUT & WIRING DIAGRAM**

COMBINED ROADWAY LIGHTING / ITS

**NOTES:**

- 1. ELECTRIC SERVICE CONDUCTORS FROM METER HOUSING.
- 2. ELECTRIC SERVICE CONDUCTORS TO LIGHTING CONTROL CONSOLE. SIZE AS INDICATED ON THE PLANS.
- 3. SURGE PROTECTION DEVICE CONDUCTORS SIZE SHALL BE ACCORDING TO MANUFACTURER'S RECOMMENDATION.
- 4. ELECTRIC CONDUCTORS SHOWN WITH MINIMUM SIZES. LARGER SIZES SHALL BE USED AS REQUIRED OR AS SHOWN ON THE PLANS.
- 5. CABLES SHALL BE MINIMUM #4 AWG OR AS REQUIRED FOR CIRCUIT BREAKER.



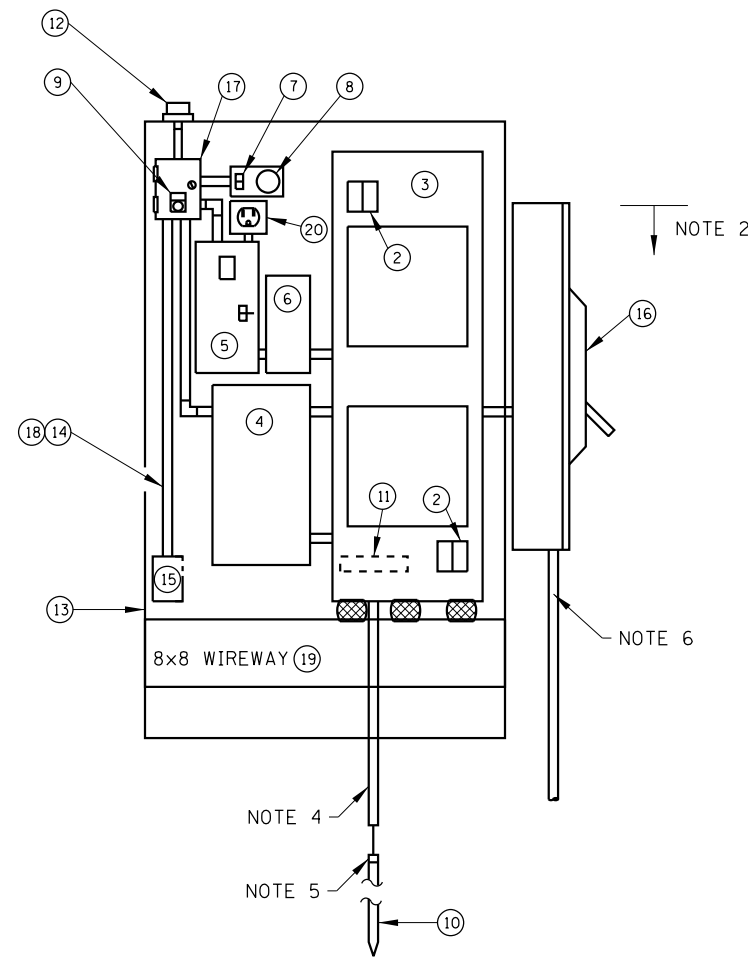

INTERIOR EQUIPMENT LAYOUT

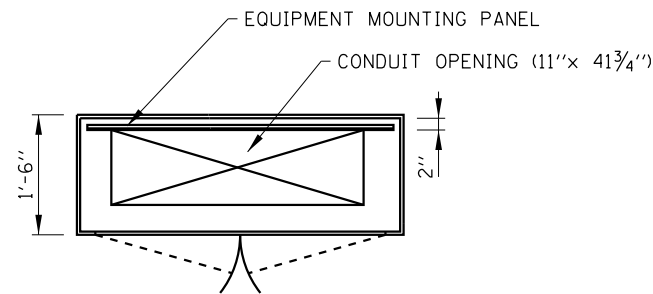

SECTION B-B

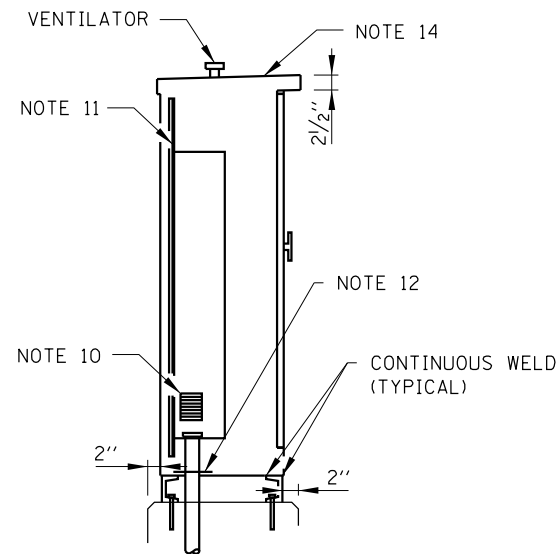

SECTION A-A

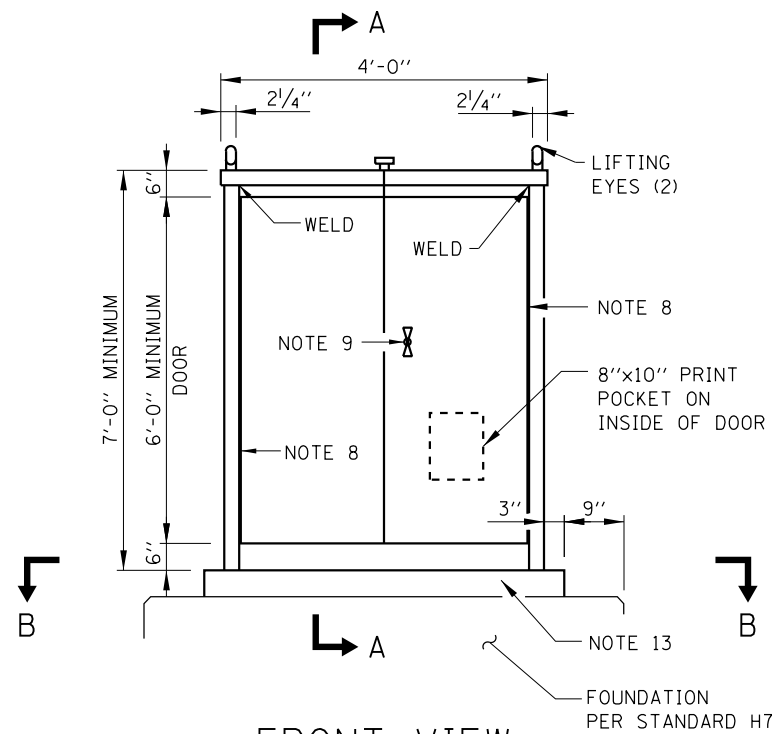

FRONT VIEW

CONTROL CONSOLE DETAILS  
(EXTERIOR INSTALLATION)

**NOTES:**

1. ALL EQUIPMENT SHALL BE GROUNDED AND BONDED IN ACCORDANCE WITH THE NATIONAL ELECTRICAL CODE AND THE NATIONAL ELECTRICAL SAFETY CODE.
2. 5'-0" MAXIMUM HEIGHT ABOVE GRADE.
3. NOT USED.
4. 3/4" PVC CONDUIT IN CONCRETE, SEE FOUNDATION DETAILS (STANDARD H7).
5. EXOTHERMIC WELD NO. 2 BARE TINNED COPPER GROUND CABLE TO GROUND ROD.
6. TO SERVICE PEDESTAL AS INDICATED ON PLANS.
7. NOT USED.
8. CONTINUOUS STAINLESS STEEL PIANO HINGES.
9. 3-POINT LATCH VAULT TYPE HANDLE WITH MASTER KEYED CHICAGO CYLINDER LOCK CATALOG NO. 60
10. SCREENED LOUVERS ON SIDES OF CABINET.
11. 10 GAUGE GALVANIZED STEEL EQUIPMENT MOUNTING PANEL (PAINTED WHITE).
12. REMOVABLE #10 GAUGE 13"x43 3/4" STAINLESS STEEL PLATE. DRILL PLATE AS REQUIRED FOR CONDUIT ENTRY.
13. 4" x 2 1/2" STAINLESS STEEL CHANNEL (2 REQUIRED-FRONT AND BACK). EXTEND CHANNEL 3" BEYOND ENCLOSURE (CONTINUOUSLY WELD CHANNEL TO ENCLOSURE).
14. TOP SLOPED 1/2" TO REAR FOR DRAINAGE.
15. FOR WIRING DIAGRAM SEE SHEET 2 OF THIS SERIES.
16. ALL EQUIPMENT WITHIN LIGHTING CONTROLLER SHALL BE SEPERATED A MINIMUM OF THREE (3) INCHES FROM EACHOTHER.
17. MAIN PANELBOARD (ITEM 3) SHALL BE POSITIONED SUCH THAT BOTH DOORS (DOOR-IN-DOOR) OF THE PANELBOARD MAY BE FULLY OPENED WITHIN EXTERIOR ENCLOSURE (ITEM 13) WITHOUT REMOVAL

**ITEM DESCRIPTION:**

- ① NOT USED.
- ② SECONDARY SURGE ARRESTERS, 2 POLE, 650 VOLT.
- ③ MAIN PANELBOARD IN A NEMA 1 ENCLOSURE, 480/240 VOLT, 1 PHASE, 3 WIRE, 2 SECTION, 200 AMP, 2 POLE MAIN CIRCUIT BREAKER 65,000 AMPERES SYMMETRICAL INTERRUPTING CAPACITY WITH CIRCUIT BREAKERS PER SCHEDULE ON PLANS. DOOR HINGES ON RIGHT SIDE.
- ④ LIGHTING CONTACTOR, ELECTRICALLY HELD, 480 VOLT, 200 AMP, 2 POLE, 120 VOLT CONTROL, WITH 250 VOLT, 15 AMP CONTROL LINE FUSE, IN A NEMA 1 ENCLOSURE.
- ⑤ SECONDARY BREAKER, 15 AMPERE TRIP, 120 VOLT, SINGLE POLE, 65,000 AMPERES SYMMETRICAL INTERRUPTING CAPACITY IN A NEMA 1 SURFACE MOUNTED ENCLOSURE.
- ⑥ STEP DOWN TRANSFORMER, 1500 VA, 480 VOLT PRIMARY, 120 VOLT SECONDARY, SINGLE PHASE, 60 HERTZ, DRY TYPE, NEMA 3R ENCLOSURE.
- ⑦ SINGLE POLE, 15 AMPERE SWITCH, IN A NEMA 1 ENCLOSURE (WITH ITEM 8), RATED AT 120-277 VAC.
- ⑧ LAMP HOLDER 660W, 600V, MOUNTED ON A NEMA 1 ENCLOSURE (WITH ITEM 7), W/LED LAMP.
- ⑨ HAND-OFF-AUTO SELECTOR SWITCH WITH LEGEND PLATE. MOUNTED IN THE COVER OF ITEM 17.
- ⑩ 5/8" DIA. x 10'-0" LONG GROUND ROD DRIVEN EXTERNAL TO THE FOUNDATION WITHIN GROUND WELL.
- ⑪ GROUND BUS MOUNTED IN PANELBOARD ENCLOSURE.
- ⑫ PHOTO ELECTRIC CONTROL SWITCH, WITH RECEPTACLE.
- ⑬ NEMA TYPE 3R STAINLESS STEEL ENCLOSURE WITH DRIP SHIELD AND STAINLESS STEEL HARDWARE. ENCLOSURE SHALL CONFORM TO J.I.C. STANDARDS WITH CELLULAR NEOPRENE GASKETED DOORS, ALL SEAMS CONTINUOUSLY WELDED, 10 GAUGE STAINLESS STEEL BODY, REMOVABLE STEEL (PAINTED WHITE) PANEL INSIDE THE BACK AND A FACTORY INSTALLED DRIP SHIELD. THE ENCLOSURE SHALL HAVE CONTINUOUS HINGED DOORS MEETING IN THE CENTER, OVERLAPPED AND GASKETED, WITH NO CENTERPOST. AN OIL TIGHT KEY LOCKING HANDLE WITH 3 POINT LATCH SHALL BE PROVIDED (FURNISH 6 KEYS). EACH END OF THE ENCLOSURE SHALL HAVE A SCREENED, GASKETED VENTILATING LOUVER AND THE TOP OF THE ENCLOSURE SHALL HAVE A VENTILATOR. INTERNAL CONDUIT SHALL HAVE LOCKNUTS, INSULATING BUSHING AND CONDULET FITTINGS AS REQUIRED. INTERNAL WIRING SHALL BE XLP INSULATED NEC TYPE RHH/RHW-2. PROVIDE A WIRING DIAGRAM IN A PRINT POCKET ON THE INSIDE OF THE CABINET DOOR.
- ⑭ INTERNAL CONTROL WIRING SHALL BE #12 AWG, STRANDED, XLP INSULATED NEC TYPE RHH/RHW-2 RATED 600 VOLT, WITH SUITABLE COLOR CODING TO BE APPROVED BY THE ENGINEER BEFORE CONSTRUCTION.
- ⑮ 200 WATT, 120 VOLT CABINET HEATER WITH INTEGRAL THERMOSTAT.
- ⑯ SERVICE SAFETY SWITCH, 200 AMP, 600 VOLT, NON-FUSED, NEMA 4X STAINLESS STEEL ENCLOSURE.
- ⑰ NEMA TYPE 1, 8"x6"x4" JUNCTION BOX & COVER WITHOUT KNOCKOUTS. ITEM 9 IS MOUNTED IN THE COVER.
- ⑱ INTERNAL CONDUIT AND FITTINGS SHALL BE 3/4" MINIMUM.
- ⑳ 8"x8" WIREWAY WITH 3-3" NIPPLES.
- ㉑ GCFI OUTLET.



EXTERIOR  
CONTROL CONSOLE  
DETAILS

STANDARD H6-06

DATE	REVISIONS
3-31-2014	REVISED NOTES AND ITEM DESCRIPTIONS.
3-11-2015	REVISED CONDUITS TO STAINLESS STEEL.
3-31-2016	REVISED NOTE 2.
3-31-2017	REMOVED METER HOUSING.
3-01-2018	REMOVED CONTACTOR RELAY, ADDED GCFI OUTLET.

*Paul Kovacs*  
APPROVED. CHIEF ENGINEERING OFFICER DATE 2-7-2012.

**NOTES:**

1. ALL EQUIPMENT SHALL BE GROUNDED AND BONDED IN ACCORDANCE WITH THE NATIONAL ELECTRICAL CODE AND THE NATIONAL ELECTRICAL SAFETY CODE.
2. TO SERVICE PEDESTAL, 480/240V, 1 PHASE, 3 WIRE, GROUNDED. SEE STANDARD H5.
3. ITEM NUMBERS REFER TO EQUIPMENT LIST ON SHEET 1 OF THIS SERIES.
4. PROVIDE CIRCUIT BREAKERS PER SCHEDULE ON THE CONTRACT PLANS (MINIMUM OF 12).
5. FOR INTERIOR EQUIPMENT LAYOUT SEE SHEET 1 OF THIS SERIES.

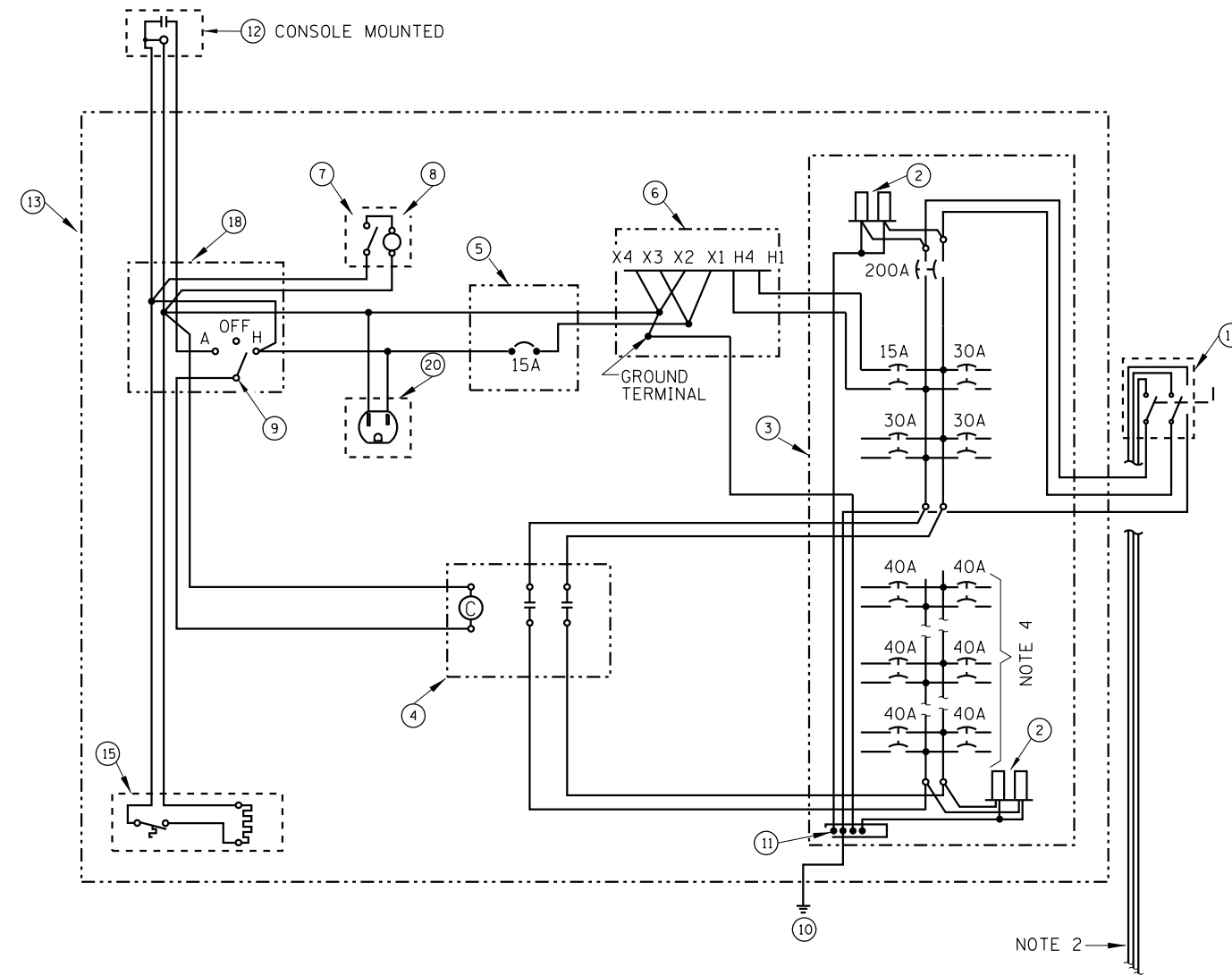

CONTROL CONSOLE WIRING DIAGRAM

CONTROL CONSOLE DETAILS  
(EXTERIOR INSTALLATION)



EXTERIOR  
CONTROL CONSOLE  
DETAILS

STANDARD H6-06

*Paul Kovacs*  
APPROVED, CHIEF ENGINEERING OFFICER DATE 2-7-2012.



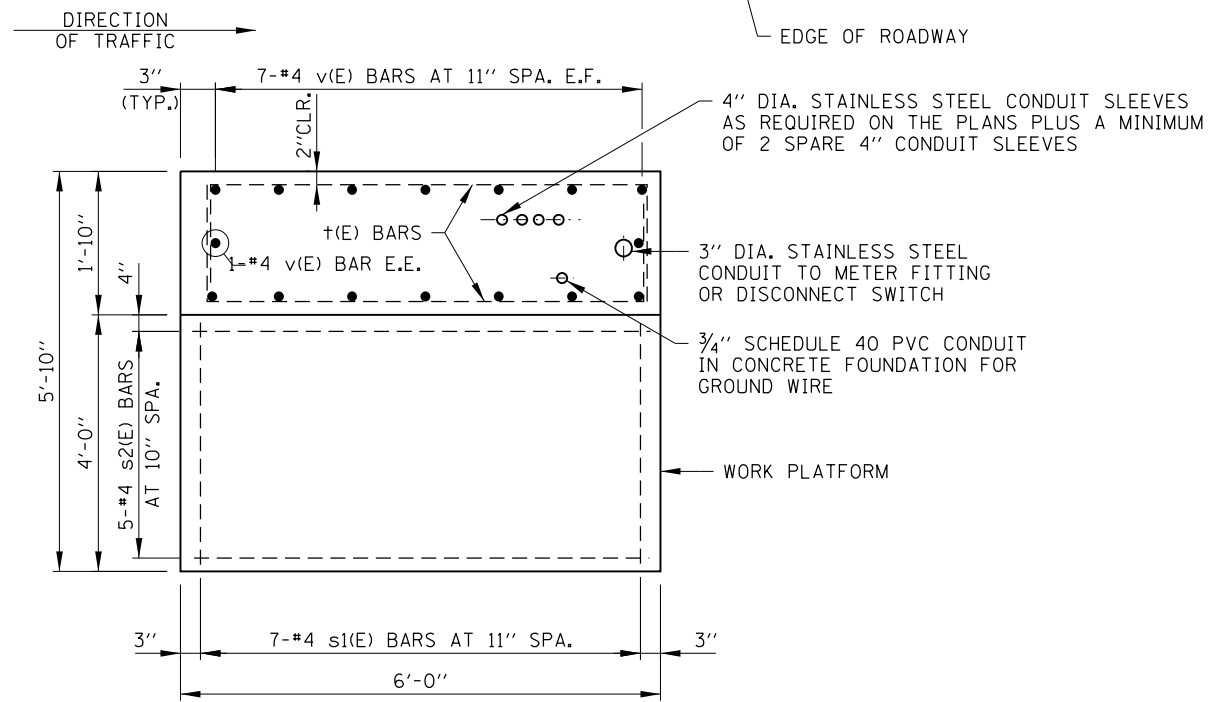

PLAN

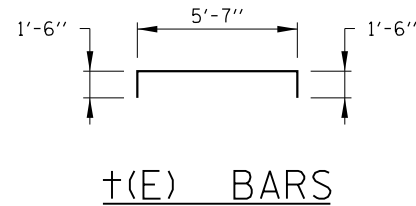

NOTES:

1. EXPOSED CONCRETE EDGES SHALL HAVE 3/4"x45° CHAMFERS EXCEPT WHERE SHOWN OTHERWISE. CHAMFERS ON VERTICAL EDGES SHALL BE CONTINUED A MINIMUM OF ONE FOOT BELOW FINISHED GROUND LEVEL.
2. ALL REINFORCEMENT BARS SHALL BE EPOXY COATED (E) AND SHALL CONFORM TO THE REQUIREMENTS OF AASHTO M-31 (ASTM A615), GRADE 60 DEFORMED BARS.
3. REINFORCEMENT BENDING DETAILS SHALL BE IN ACCORDANCE WITH THE "MANUAL OF STANDARD PRACTICE FOR DETAILING REINFORCED CONCRETE STRUCTURES", ACI 315, LATEST EDITION.
4. REINFORCEMENT BAR BENDING DIMENSIONS ARE OUT TO OUT.
5. COVER FROM THE FACE OF CONCRETE TO FACE OF REINFORCEMENT BARS SHALL BE 3" FOR ALL SURFACES UNLESS OTHERWISE SHOWN.
6. FOR CLARITY, CONTROL CONSOLE AND RAILINGS ARE NOT SHOWN IN PLAN VIEW.
7. ALL EQUIPMENT SHALL BE GROUNDED AND BONDED IN ACCORDANCE WITH THE NATIONAL ELECTRICAL CODE AND THE NATIONAL ELECTRICAL SAFETY CODE.

REINFORCEMENT BARS SCHEDULE					
BARS	NO.	SIZE	LENGTH	WT. LB.	SHAPE
v(E)	16	#4	4'-0"	43	—
t(E)	10	#4	8'-7"	57	⌌
s1(E)	7	#4	3'-8"	17	—
s2(E)	5	#4	5'-8"	19	—

BILL OF MATERIAL		
DESCRIPTION	UNIT	QUANTITY
REINF. BARS, EPOXY COATED	POUND	136
CLASS "SI" CONCRETE	CU. YD.	2.3

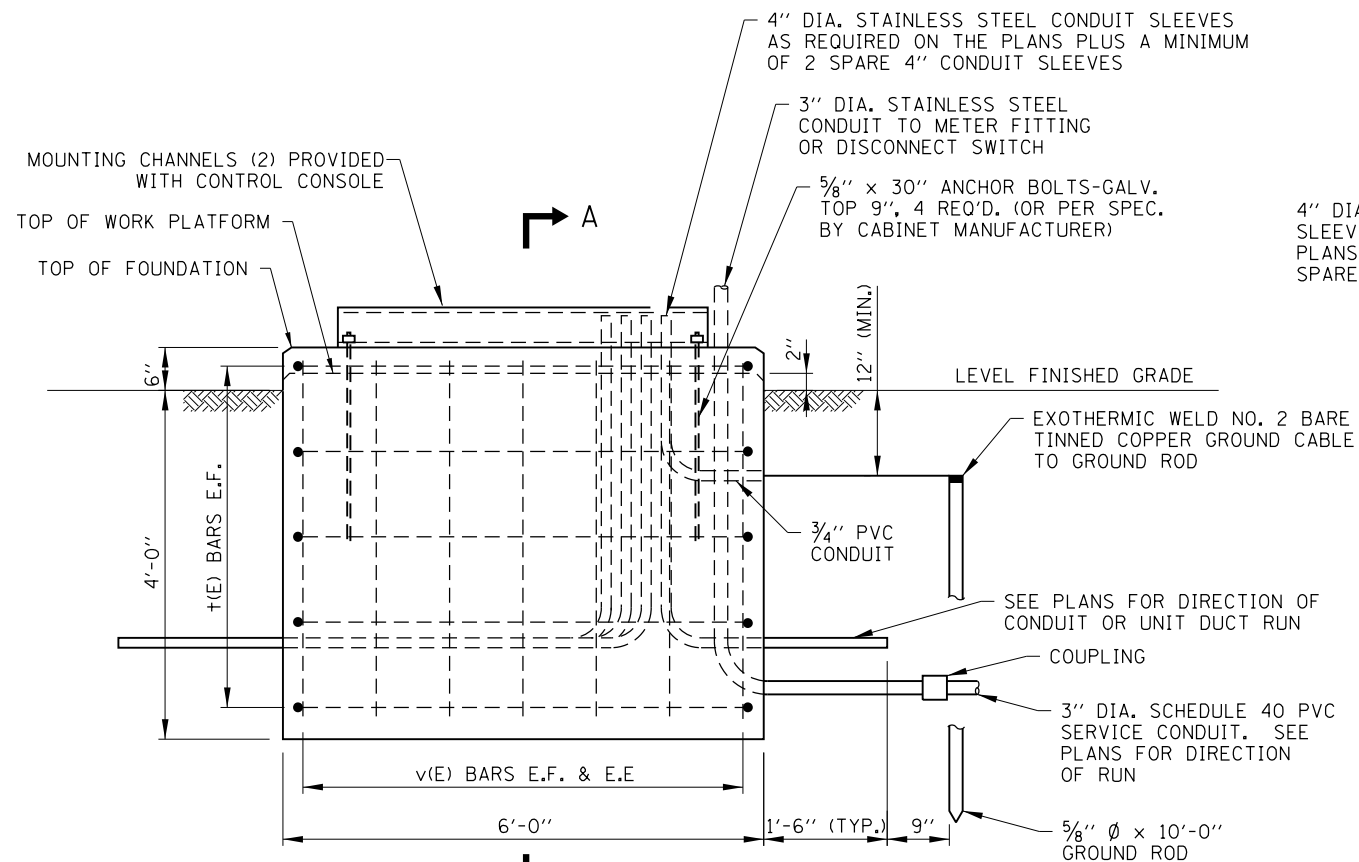

ELEVATION

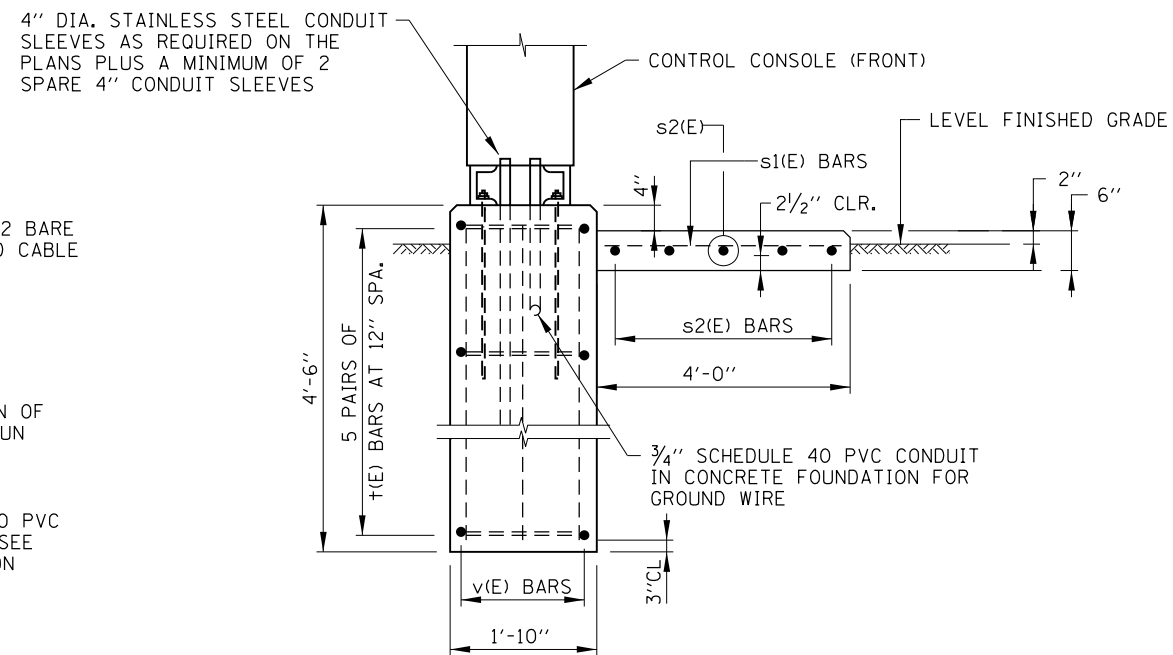

SECTION A-A



APPROVED: *Paul Kovacs*  
 CHIEF ENGINEER DATE: 2-7-2012

TYPE A CONTROL CONSOLE FOUNDATION

DATE	REVISIONS
2-07-2012	REVISED TYPE A AND TYPE B CONTROL CONSOLE FOUNDATIONS.
3-11-2015	REVISED CONDUITS TO STAINLESS STEEL.
3-04-2019	REVISED CONDUITS TO MATCH H5

EXTERIOR CONTROL CONSOLE FOUNDATION DETAILS

STANDARD H7-03

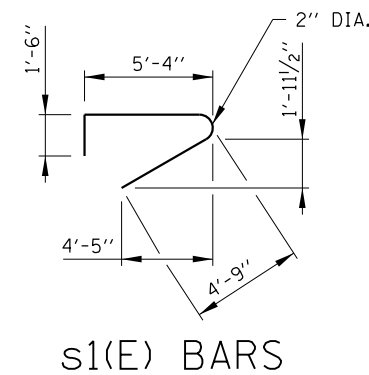
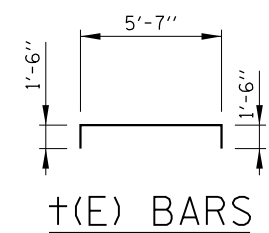
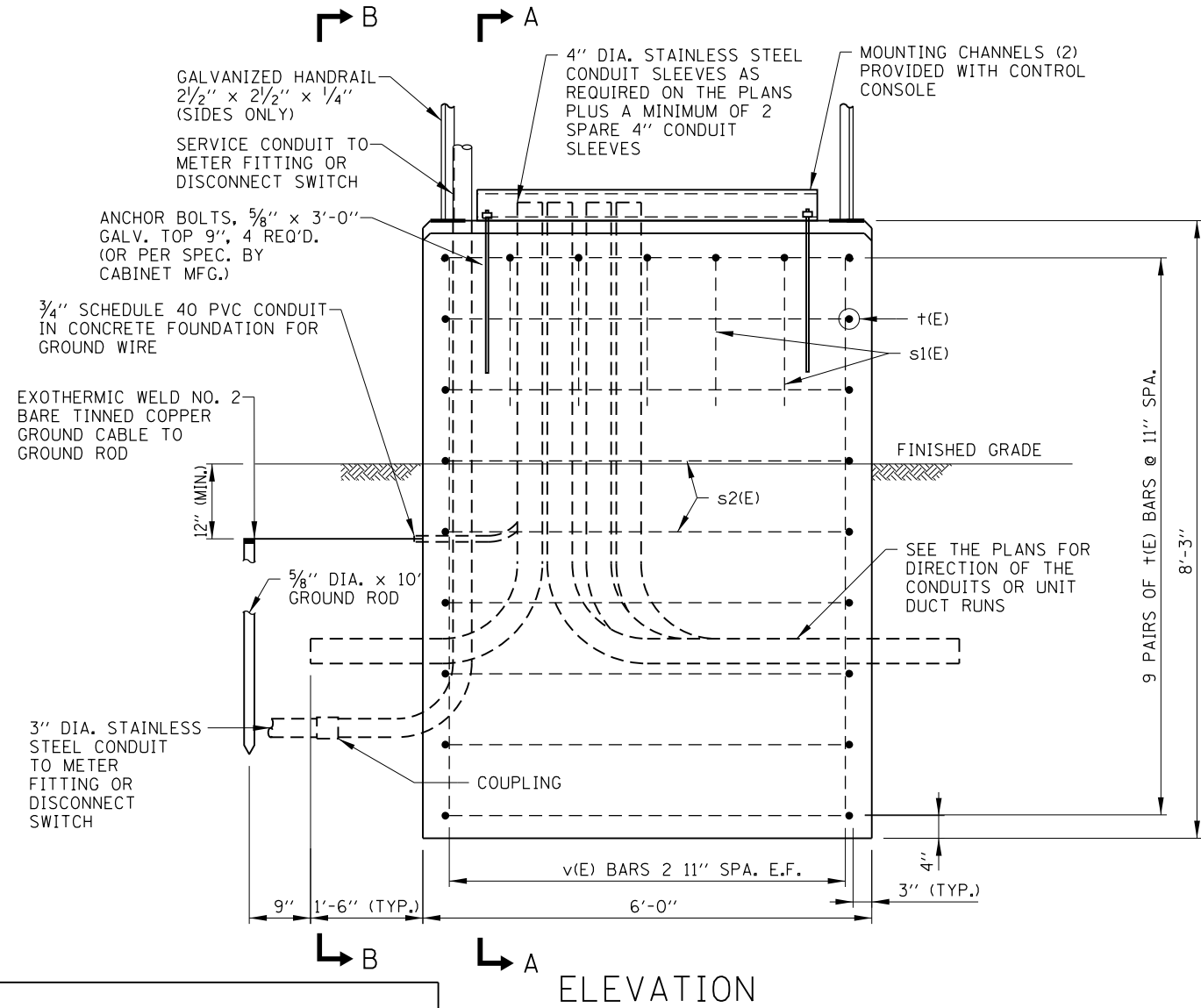
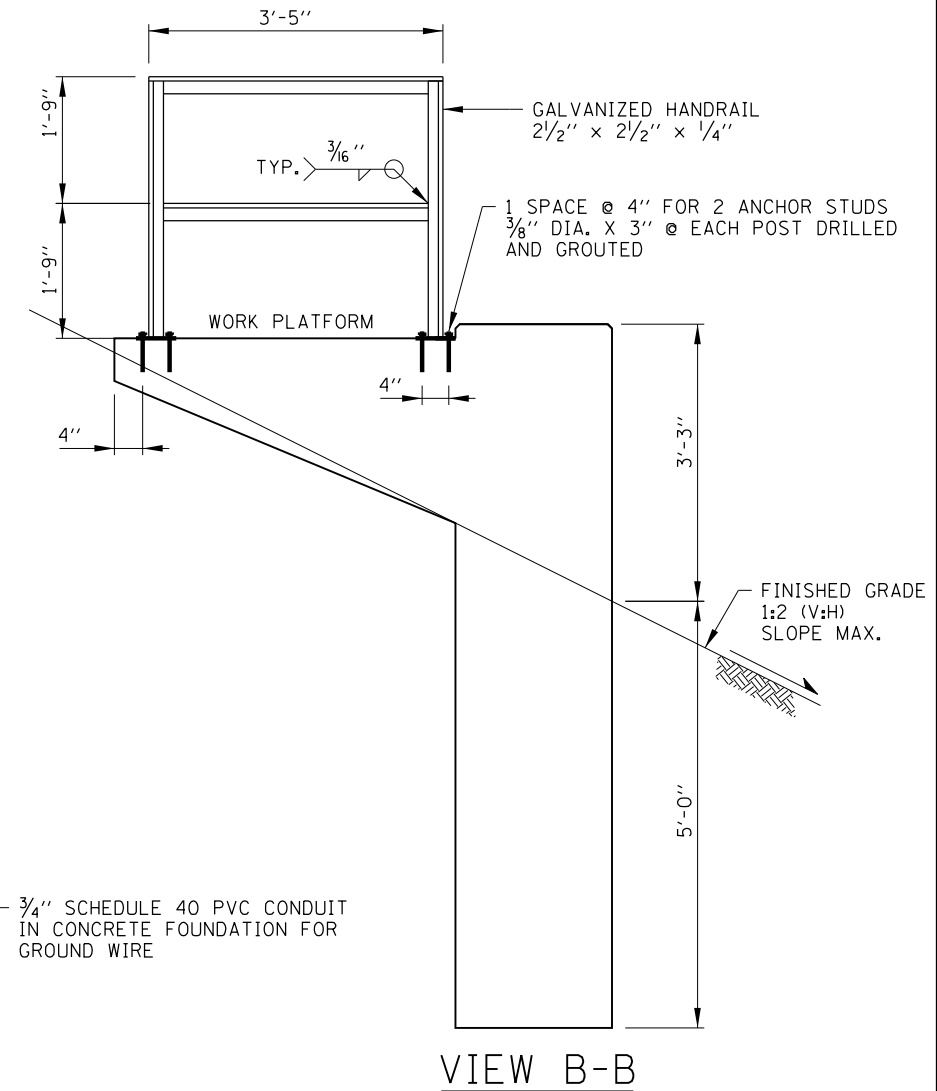
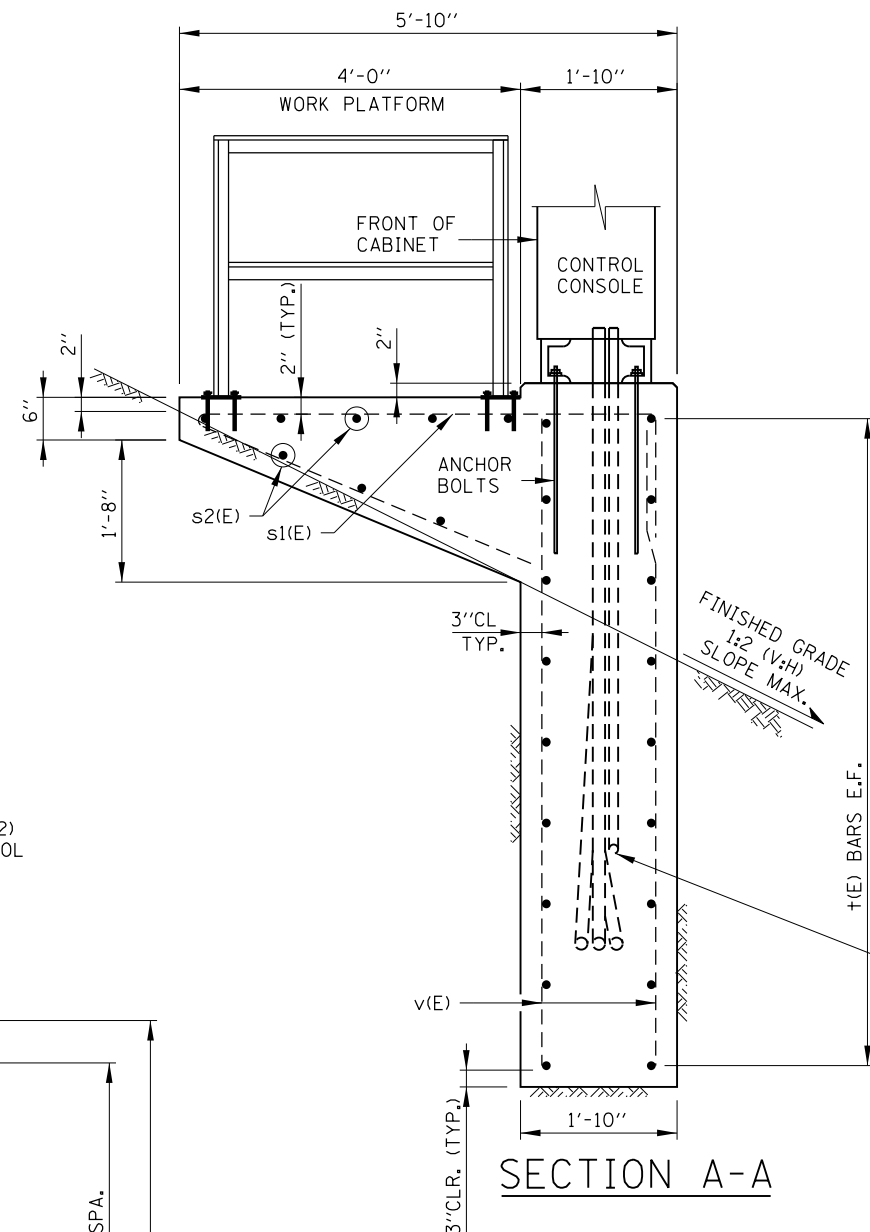
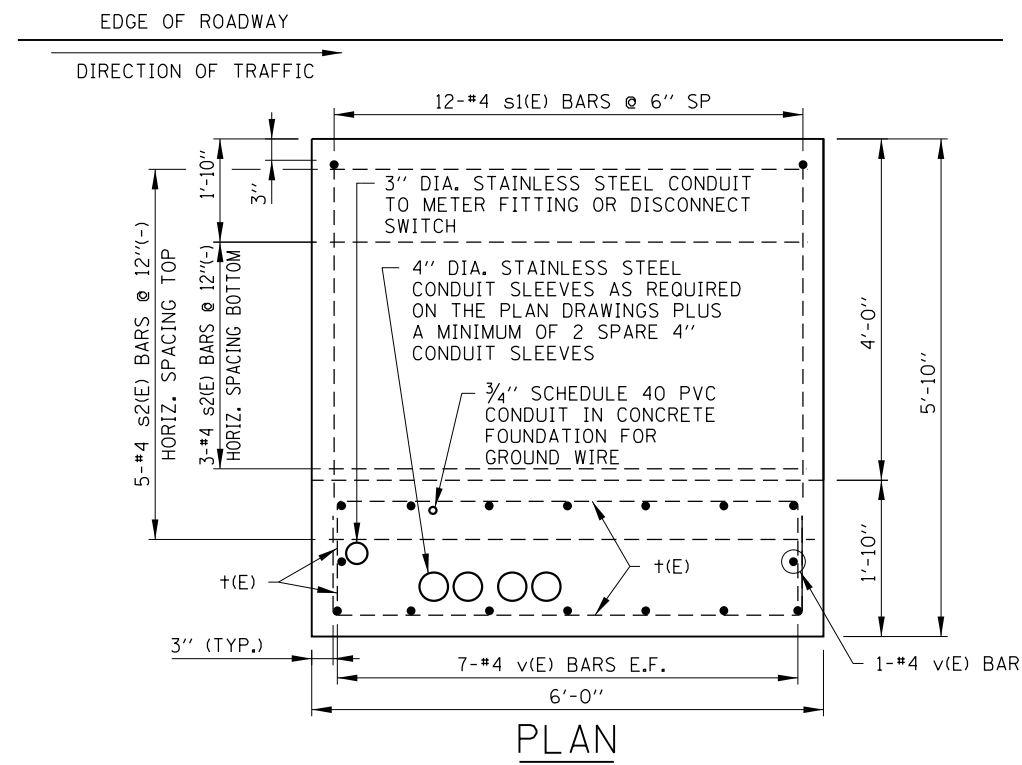

REINFORCEMENT BARS SCHEDULE					
BARS	NO.	SIZE	LENGTH	WT. LB.	SHAPE
v(E)	16	#4	7'-10"	84	—
t(E)	18	#4	8'-7"	103	┌
s1(E)	12	#4	11'-9"	94	└
s2(E)	8	#4	5'-6"	29	—

BILL OF MATERIAL		
DESCRIPTION	UNIT	QTY
REINF. BARS, EPOXY COATED	POUND	310
CLASS "SI" CONCRETE	CU. YD.	9.4
STRUCTURAL STEEL	POUND	158

Paul Kovacs  
APPROVED... CHIEF ENGINEER... DATE 2-7-2012

TYPE B CONTROL CONSOLE FOUNDATION

NOTES:  
SEE SHEET 1 OF THIS SERIES FOR NOTES.

SHEET 2 OF 2

EXTERIOR CONTROL CONSOLE FOUNDATION DETAILS

STANDARD H7-03

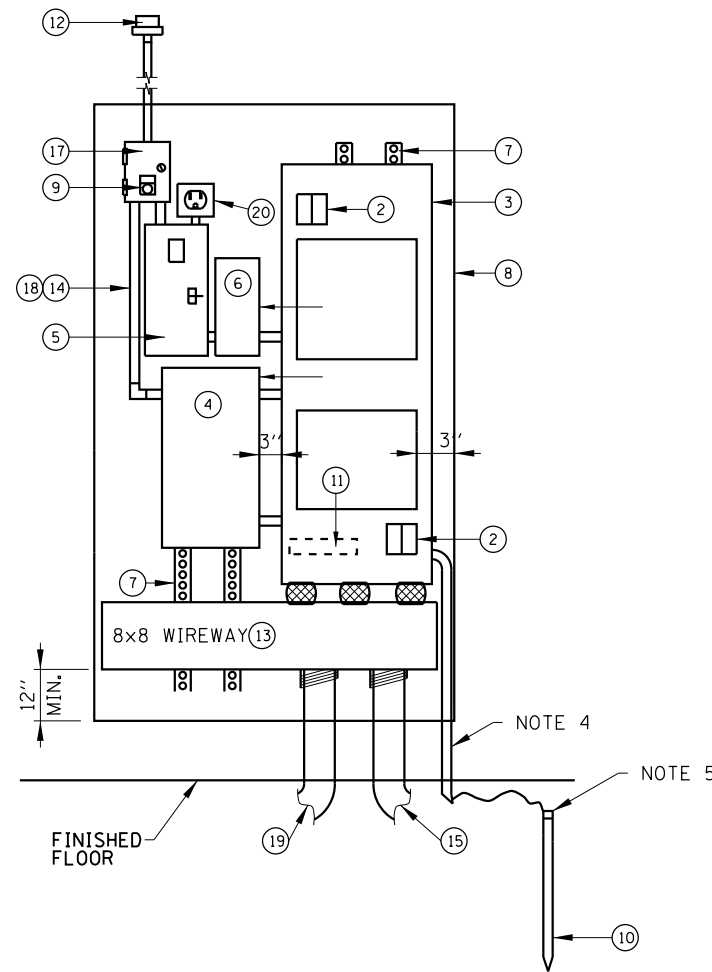

INTERIOR EQUIPMENT LAYOUT

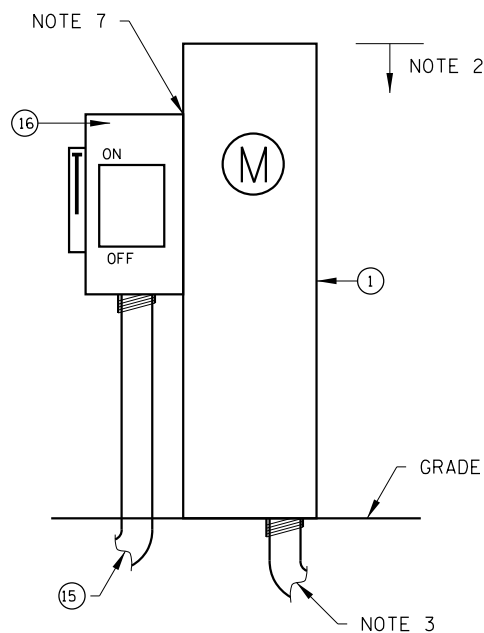

SERVICE ENTRANCE DETAIL

**NOTES:**

1. PROVIDE POWER UTILITY CO. METER HOUSING AS INDICATED ON PLANS.
2. 5'-0" MAXIMUM HEIGHT ABOVE GRADE.
3. STAINLESS STEEL CONDUIT TO UTILITY SERVICE AS INDICATED ON PLANS.
4. 3/4" PVC CONDUIT.
5. EXOTHERMIC WELD NO. 2 BARE TINNED COPPER GROUND CABLE TO GROUND ROD 12"-24" BELOW GRADE.
6. TO POWER UTILITY COMPANY, SERVICE AS INDICATED ON PLANS.
7. CONDUIT AND CABLE BETWEEN METER FITTING AND DISCONNECT SWITCH. CONDUIT AND CABLE SHALL BE THE SAME AS THE SERVICE.
8. LABEL ALL EQUIPMENT AS "ROADWAY LIGHTING" + DEVICE AND BUILDING\* (IF APPLICABLE).
9. FOR WIRING DIAGRAM SEE SHEET 2 OF THIS SERIES.
10. ALL EQUIPMENT SHALL BE GROUNDED AND BONDED IN ACCORDANCE WITH THE NATIONAL ELECTRICAL CODE AND THE NATIONAL ELECTRICAL SAFETY CODE.

**ITEM**

**DESCRIPTION**

- |   |   |
|---|---|
| <ol style="list-style-type: none"> <li>①</li> <li>②</li> <li>③</li> <li>④</li> <li>⑤</li> <li>⑥</li> <li>⑦</li> <li>⑧</li> <li>⑨</li> <li>⑩</li> <li>⑪</li> <li>⑫</li> <li>⑬</li> <li>⑭</li> <li>⑮</li> <li>⑯</li> <li>⑰</li> <li>⑱</li> <li>⑳</li> </ol> | <p>METER HOUSING, MILBANK U8436-0.</p> <p>SECONDARY SURGE ARRESTERS, 2 POLE, 650 VOLT.</p> <p>MAIN PANELBOARD IN A NEMA 1 ENCLOSURE, 480/240 VOLT, 1 PHASE, 3 WIRE, 2 SECTION, 200 AMP, 2 POLE MAIN CIRCUIT BREAKER 65,000 AMPERES SYMMETRICAL INTERRUPTING CAPACITY WITH CIRCUIT BREAKERS PER SCHEDULE ON PLANS. DOOR HINGES ON RIGHT SIDE.</p> <p>LIGHTING CONTACTOR, ELECTRICALLY HELD, 480 VOLT, 200 AMP, 2 POLE, 120 VOLT CONTROL, WITH 250 VOLT, 15 AMP CONTROL LINE FUSE, IN A NEMA 1 ENCLOSURE.</p> <p>SECONDARY BREAKER, 15 AMPERE TRIP, 120 VOLT, SINGLE POLE, 65,000 AMPERES SYMMETRICAL INTERRUPTING CAPACITY IN A NEMA 1 SURFACE MOUNTED ENCLOSURE.</p> <p>STEP DOWN TRANSFORMER, 1500 VA, 480 VOLT PRIMARY, 120 VOLT SECONDARY, SINGLE PHASE, 60 HERTZ, DRY TYPE, NEMA 3R ENCLOSURE.</p> <p>1/4" X 3/4" C-CHANNEL (UNISTRUT) FOR ALL EQUIPMENT STANDOFF</p> <p>1/2" EQUIPMENT MOUNTING PANEL (4' W X 7' H)</p> <p>HAND-OFF-AUTO SELECTOR SWITCH WITH LEGEND PLATE. MOUNTED IN THE COVER OF ITEM 17.</p> <p>ROUTED TO BUILDING GROUND SYSTEM. IF NO GROUND AVAILABLE CONTRACTOR SHALL PROVIDE 5/8" DIA. X 10'-0" LONG GROUND ROD WITHIN GROUND WELL.</p> <p>GROUND BUS MOUNTED IN PANELBOARD ENCLOSURE.</p> <p>PHOTO ELECTRIC CONTROL SWITCH MOUNTED ON SOUTH EXTERIOR SIDE OF BUILDING (VIEW UNOBSTRUCTED).</p> <p>8"x8" WIREWAY WITH 3-3" NIPPLES.</p> <p>INTERNAL CONTROL WIRING SHALL BE #12 AWG, STRANDED, INSULATED NEC TYPE THWN/THHN RATED 600 VOLT, WITH SUITABLE COLOR CODING TO BE APPROVED BY THE ENGINEER BEFORE CONSTRUCTION.</p> <p>2" STAINLESS STEEL CONDUIT FROM SERVICE SAFETY SWITCH TO LIGHTING CONTROLLER WIREWAY.</p> <p>SERVICE SAFETY SWITCH, 200 AMP, 600 VOLT, NON-FUSED, NEMA 4X STAINLESS STEEL ENCLOSURE.</p> <p>NEMA TYPE 1, 8"x6"x4" JUNCTION BOX &amp; COVER WITHOUT KNOCKOUTS. ITEM 9 IS MOUNTED IN THE COVER.</p> <p>INTERNAL CONDUIT AND FITTINGS SHALL BE 3/4" MINIMUM.</p> <p>(2) 4" STAINLESS STEEL CONDUIT TO LIGHTING CONTROLLER HANDHOLE. REFER TO SITE PLAN FOR LOCATION.</p> <p>GCFI OUTLET.</p> |
|---|---|



INTERIOR  
CONTROL CONSOLE  
DETAILS

STANDARD H8-03

DATE	REVISIONS
3-31-2016	REVISED NOTE 2.
3-01-2017	REMOVED MFR. & PART NUMBERS
3-01-2018	REMOVED CONTACTOR RELAY, ADDED GCFI OUTLET.

CONTROL CONSOLE DETAILS  
(INTERIOR INSTALLATION)

*Paul Kovacs*  
APPROVED, CHIEF ENGINEERING OFFICER DATE 2-7-2012.

**NOTES:**

1. TO UTILITY SERVICE. 480/240V, 1 PHASE, 3 WIRE, GROUNDED, WHEN A METER HOUSING IS REQUIRED (FED FROM PAD MOUNTED UTILITY TRANSFORMER WITHIN ILLINOIS TOLLWAY RIGHT-OF-WAY).
2. TO SERVICE PEDESTAL, 480/240V, 1 PHASE, 3 WIRE, GROUNDED. SEE STANDARD H5.
3. ITEM NUMBERS REFER TO EQUIPMENT LIST ON SHEET 1 OF THIS SERIES.
4. PROVIDE CIRCUIT BREAKERS PER SCHEDULE ON THE CONTRACT PLANS (MINIMUM OF 12).
5. FOR INTERIOR EQUIPMENT LAYOUT SEE SHEET 1 OF THIS SERIES.
6. ALL EQUIPMENT SHALL BE GROUNDED AND BONDED IN ACCORDANCE WITH THE NATIONAL ELECTRICAL CODE AND THE NATIONAL ELECTRICAL SAFETY CODE.
7. CONDUIT AND CABLE BETWEEN METER FITTING AND DISCONNECT SWITCH Routed BETWEEN CONTROL CONSOLE AND CONCRETE FOUNDATION, WHEN A METER HOUSING IS REQUIRED. CONDUIT AND CABLE SHALL BE THE SAME AS THE SERVICE.

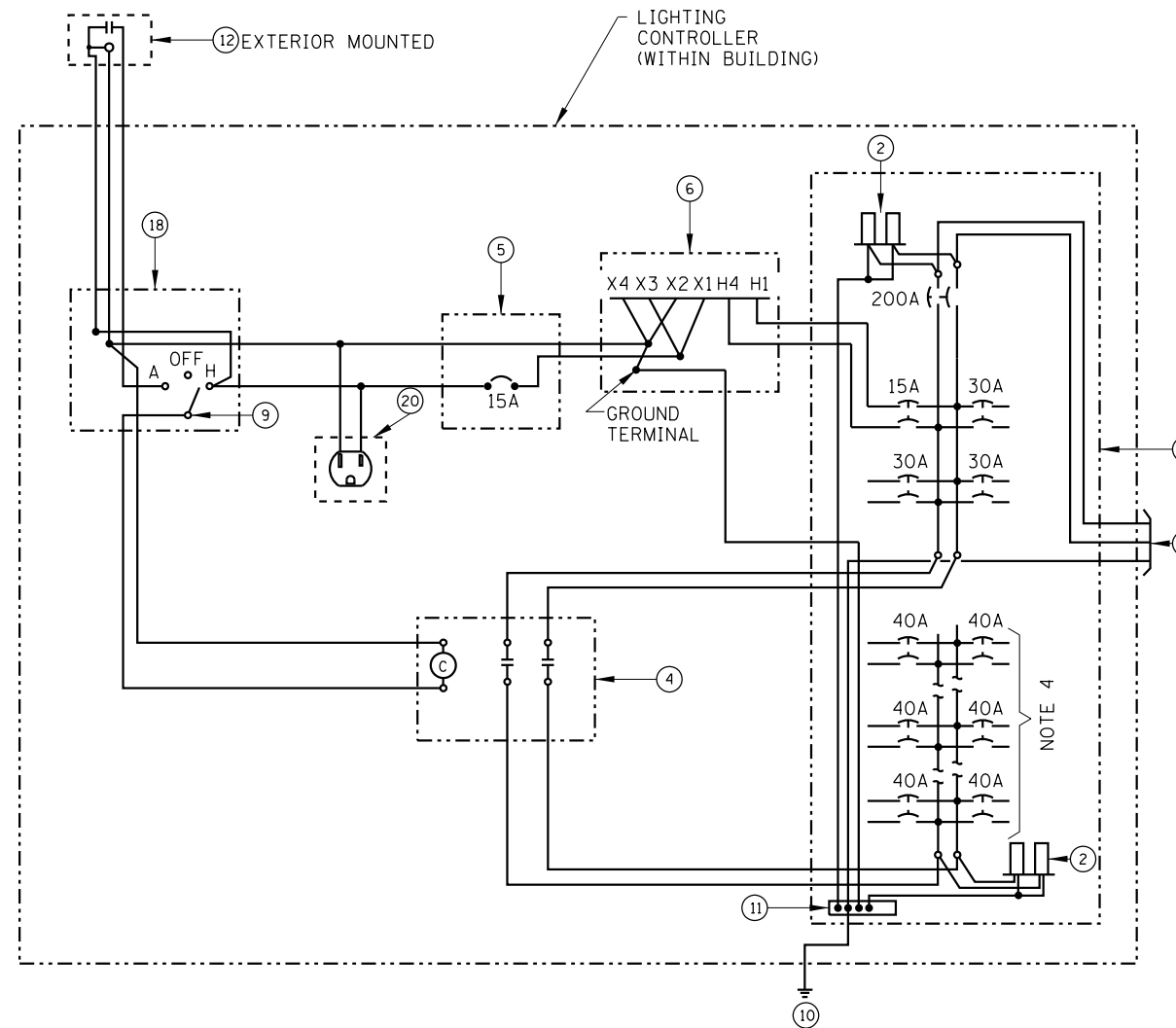

CONTROL CONSOLE WIRING DIAGRAM

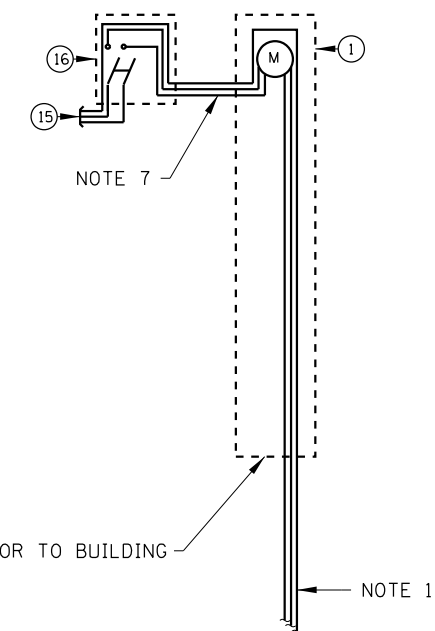

CONTROL CONSOLE DETAILS  
(INTERIOR INSTALLATION)

*Paul Kovacs*  
APPROVED, CHIEF ENGINEERING OFFICER DATE 2-7-2012.



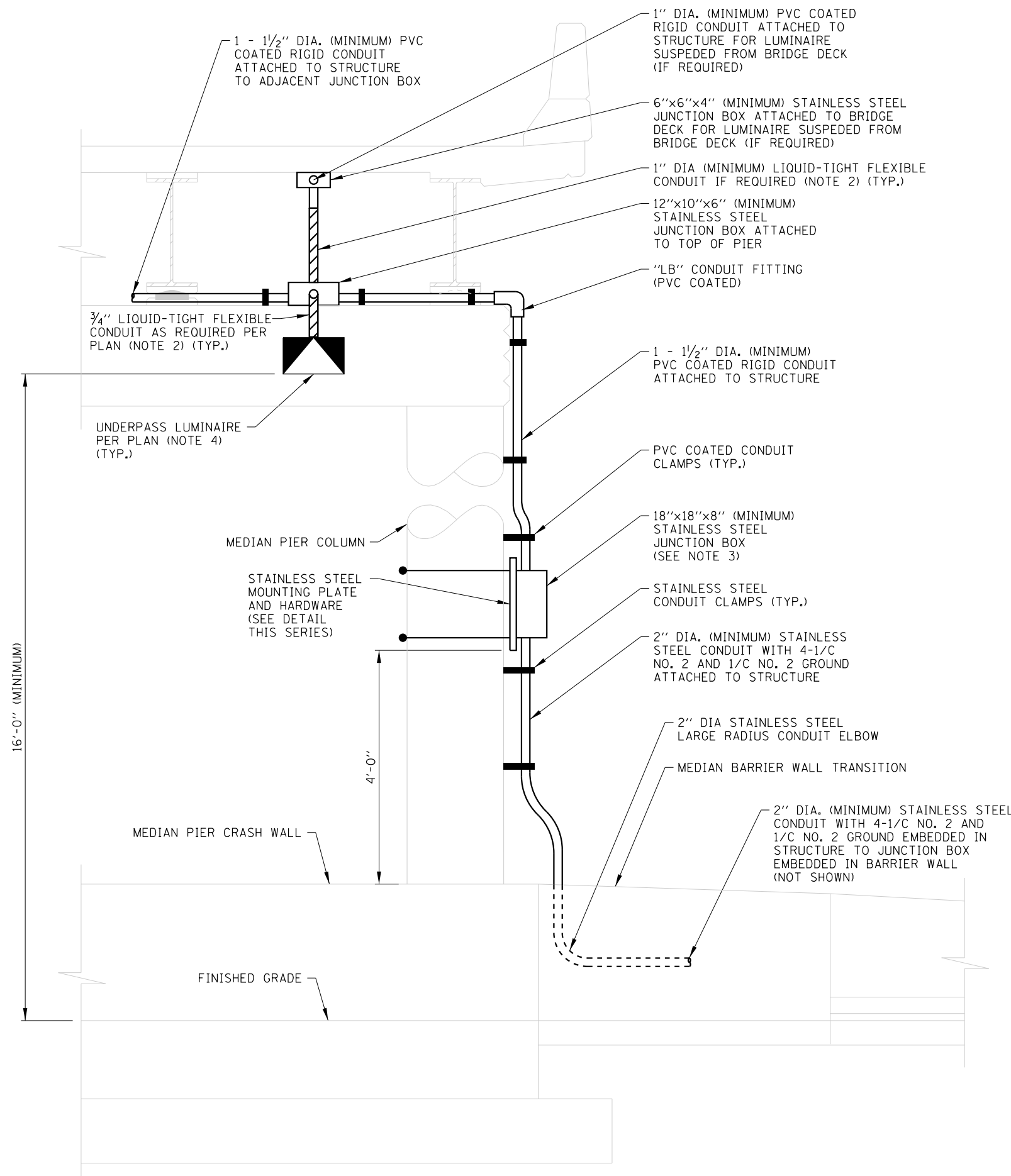

**NOTES:**

1. USE OF THIS STANDARD DETAIL IS LIMITED TO THE INSTALLATION OF LIGHT EMITTING DIODE LUMINAIRES ONLY. FOR INSTALLATION OF OTHER LIGHT SOURCE TYPES, REFER TO PLAN DETAILS.
2. LIQUID-TIGHT FLEXIBLE CONDUIT, MAXIMUM LENGTH 6'-0", TYPICAL FOR EACH INSTANCE AS SHOWN. PROVIDE SUFFICIENT LENGTH OF PVC COATED RIGID GALVANIZED STEEL CONDUIT AS REQUIRED CONDUIT AS REQUIRED SO THE MAXIMUM LENGTH OF REQUIRED LIQUID-TIGHT DOES NOT EXCEED 6'-0". LIQUID-TIGHT FLEXIBLE CONDUIT.
3. PROVIDE TWO (2) 2-POLE 30A, 600 VOLT CIRCUIT BREAKERS (EATON HFD OR APPROVED EQUAL), TWO (2) SURGE PROTECTION DEVICES (IN ACCORDANCE WITH ARTICLE 1065.02 OF THE STANDARD SPECIFICATIONS) AND SUFFICIENT 30 AMPERE, 600 VOLT TERMINAL BLOCKS TO SPLIT 480 VOLT WIRING FROM CIRCUIT BREAKER TO TWO (2) NO. 10 WIRES FOR EACH LUMINAIRE.
4. WIRING SHALL BE 2-1/C NO. 10 WITH 1/C NO. 10 GROUND OR AS INDICATED ON THE PLANS TERMINATING AT EACH LUMINAIRE. SEE PLANS FOR REMAINING WIRING REQUIREMENTS.
5. THE CONTRACTOR SHALL PROVIDE EXPANSION/DEFLECTION FITTINGS (O-Z/GEDNEY TYPE AXDX) WHERE CONDUITS CROSS STRUCTURE EXPANSION JOINTS.
6. IN NEW BRIDGE DECKS, PROVIDE STAINLESS STEEL SINGLE COIL, FLARED LOOP INSERTS CAST IN THE DECK FOR 3/4" DIAMETER STAINLESS STEEL THREADED RODS. IN EXISTING BRIDGE DECKS, PROVIDE DRILLED STAINLESS STEEL EXPANSION TYPE ANCHORS FOR 3/4" DIAMETER STAINLESS STEEL THREADED RODS. EXPANSION TYPE ANCHORS SHALL HAVE A MINIMUM OF 500 POUNDS CAPACITY EACH.
7. NOT USED.
8. ALL ITEMS MOUNTED TO BRIDGE PIER SHALL BE OFFSET FROM THE STRUCTURE A MINIMUM OF ONE (1) INCH BY USE OF STAINLESS STEEL C-CHANNEL.
9. WHERE BEAM DEPTH EXCEEDS FIVE (5) FEET, THE DESIGNER SHALL PROVIDE A METHOD FOR ATTACHMENT OF THE HANGER ASSEMBLIES SUCH THAT THE LENGTH OF THE ASSEMBLIES DO NOT EXCEED FIVE (5) FEET.
10. DETAILS SHOWN ARE FOR UNDERPASS LIGHTING INSTALLATIONS FED FROM THE MEDIAN BARRIER WALL. FOR INSTALLATIONS FED FROM A BRIDGE ABUTMENT, REFER TO THE PLAN DETAILS.
11. UNDERPASS LUMINAIRES SUSPENDED FROM BRIDGE DECK SHALL BE INSTALLED CENTERED BETWEEN THE BRIDGE BEAMS. THE LUMINAIRE SHALL BE LOCATED SUCH THAT IT IS SETBACK A MINIMUM OF 1 FOOT FROM THE OUTSIDE EDGE OF THE SHOULDER PAVEMENT WITH THE TOP OF THE LUMINAIRE MOUNTING PLATE A MAXIMUM OF 1 INCH FROM THE BOTTOM OF THE BRIDGE BEAM. IN NO CASE SHALL ANY PORTION OF THE SUSPENDED LUMINAIRE OR SUPPORTING HARDWARE BE LOWER THAN 14'-6" WHEN MEASURED TO THE OUTSIDE EDGE OF THE ADJACENT SHOULDER PAVEMENT.
12. IN NO INSTANCE SHALL ANY UNDERPASS LUMINAIRE OR ANY OTHER ELECTRICAL EQUIPMENT BE INSTALLED BELOW THE ELEVATION OF THE BOTTOM OF THE BRIDGE BEAM WHEN OVER ANY PAVEMENT (ROADWAY OR SHOULDER) WITH EXCEPTION OF THOSE MOUNTED TO THE MEDIAN PIER AT WHICH CASE THE MINIMUM HEIGHT SHALL BE 16'-0" WHEN MEASURED TO THE LOWEST PORTION OF THE LUMINAIRE OR SUPPORTING HARDWARE.
13. LUMINAIRE MOUNTING PLATE FOR LUMINAIRES SUPENDED FROM BRIDGE DECK SHALL BE OF THE DIMENSIONS NECESSARY AND FIELD DRILLED TO ACCOMODATE THE SPECIFIC LUMINAIRE PROVIDED AND ASSOCIATE LUMINAIRE HANGER ASSEMBLIES.
14. SEE PLANS FOR UNDERPASS LUMINAIRE LOCATIONS AND MOUNTING HEIGHTS.
15. SEE STRUCTURAL DRAWINGS FOR SPECIFIC STRUCTURE DETAILS.
16. ALL EQUIPMENT SHALL BE GROUNDED AND BONDED IN ACCORDANCE WITH THE NATIONAL ELECTRICAL CODE AND THE NATIONAL ELECTRICAL SAFETY CODE.



**UNDERPASS LIGHTING  
(MEDIAN PIER MOUNTED LUMINAIRE & FEEDER INSTALLATION)**

APPROVED *Paul Kovacs* CHIEF ENGINEER DATE 3-31-2016

DATE	REVISIONS
03-31-17	Revised Notes to remove incidentals

UNDERPASS LIGHTING  
INSTALLATION DETAILS

STANDARD H9-01

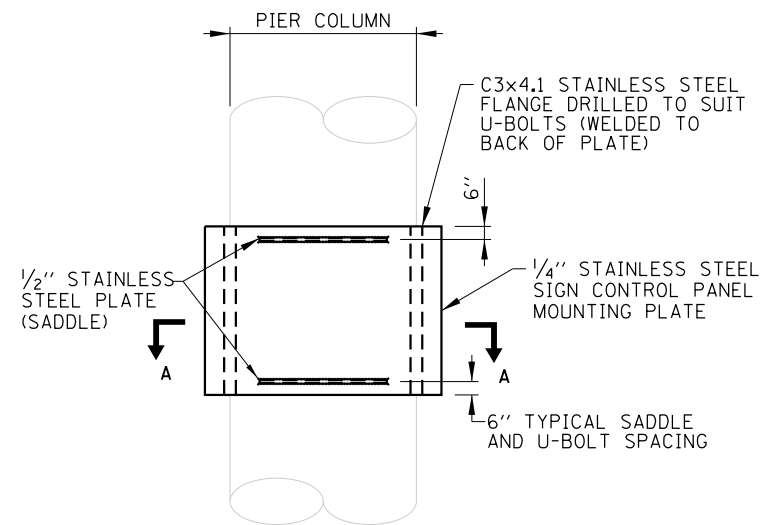

ELEVATION

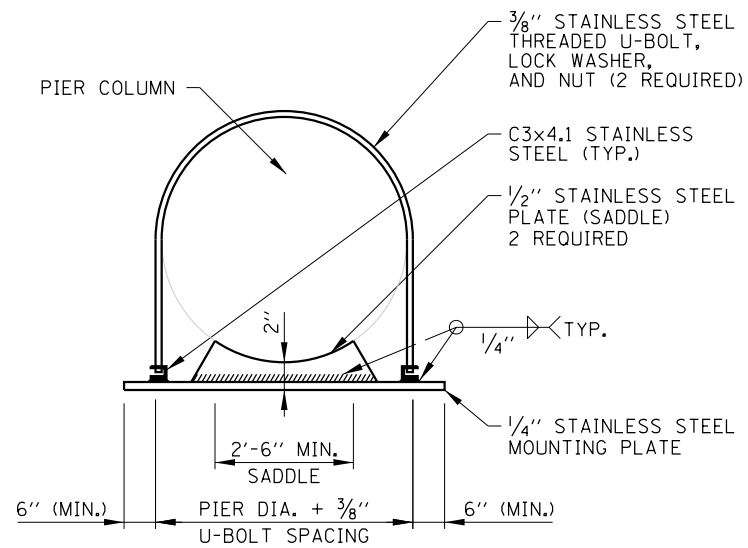

SECTION A-A

MEDIAN PIER JUNCTION BOX MOUNTING PLATE DETAIL

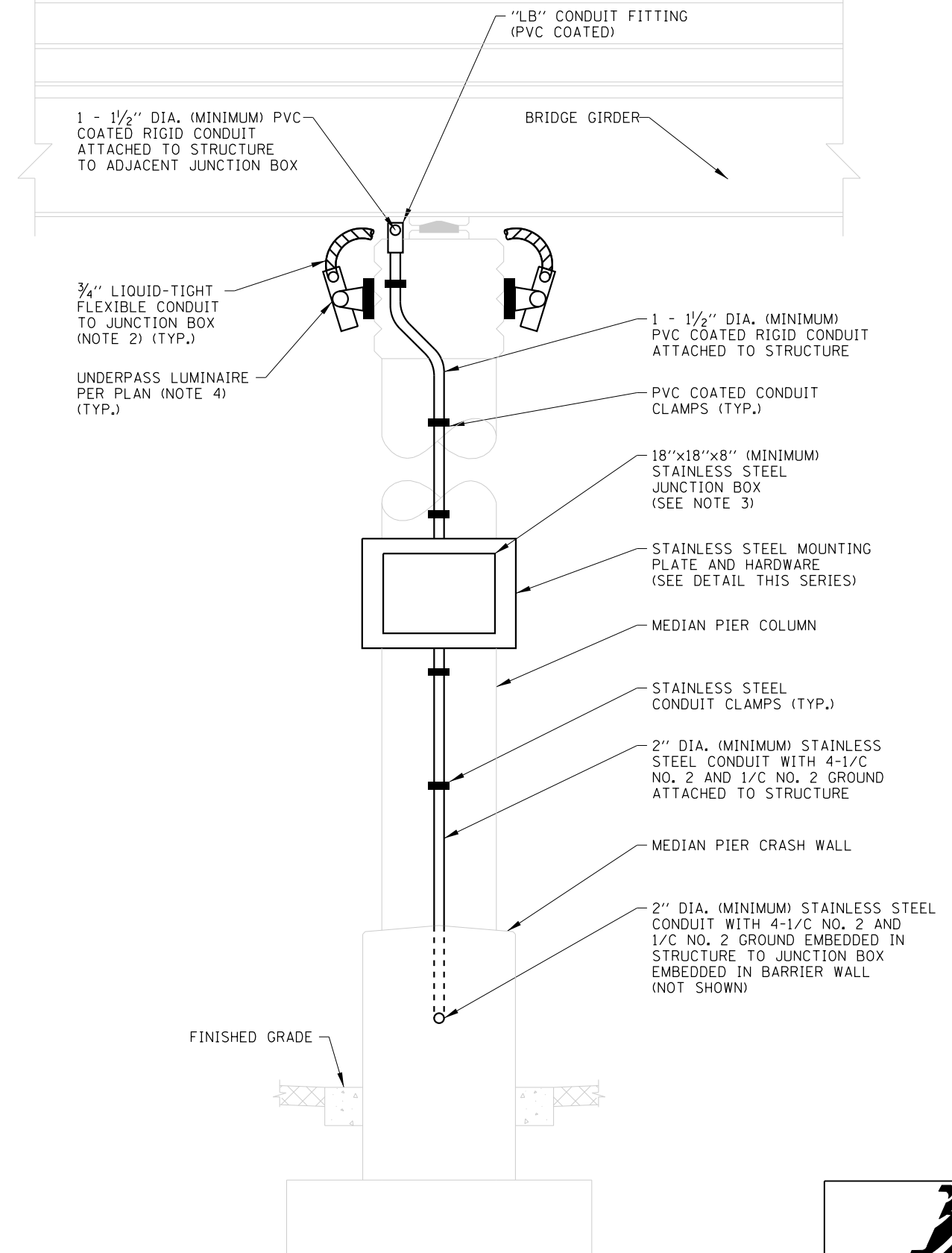

UNDERPASS LIGHTING  
(MEDIAN PIER MOUNTED LUMINAIRE & FEEDER INSTALLATION)

NOTE:  
FOR NOTES SEE SHEET 1 OF THIS SERIES.



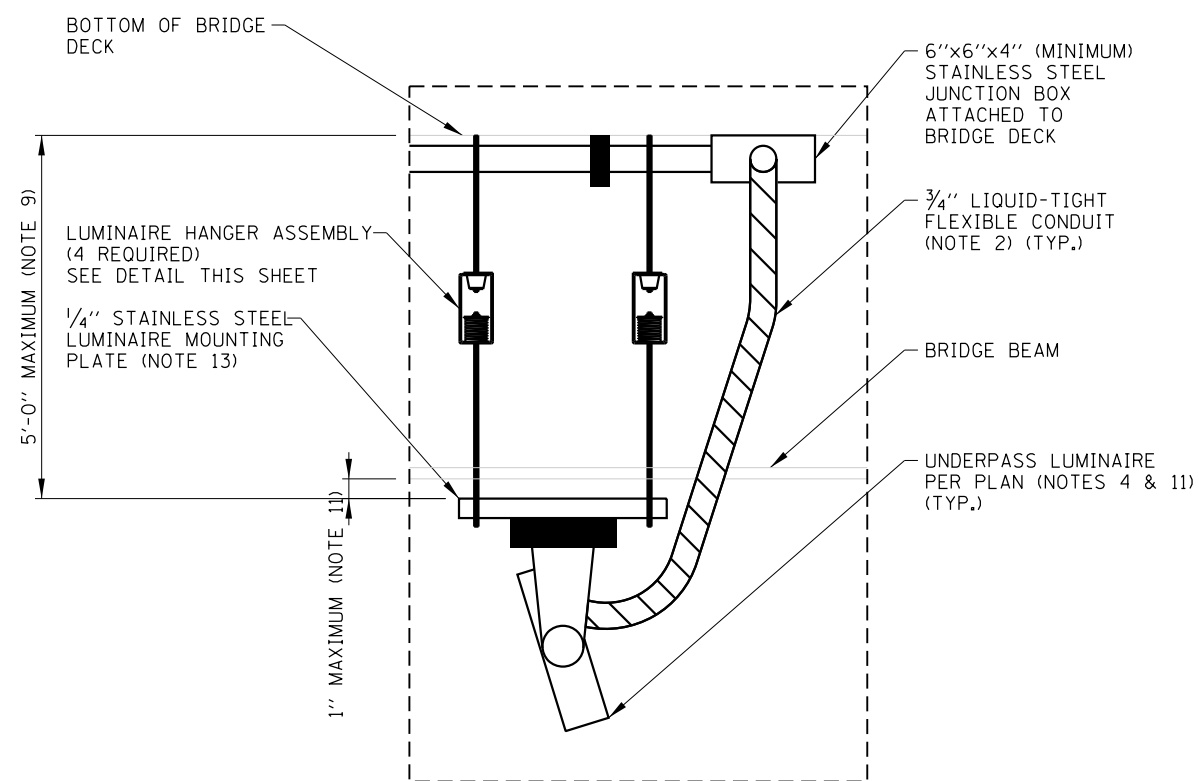
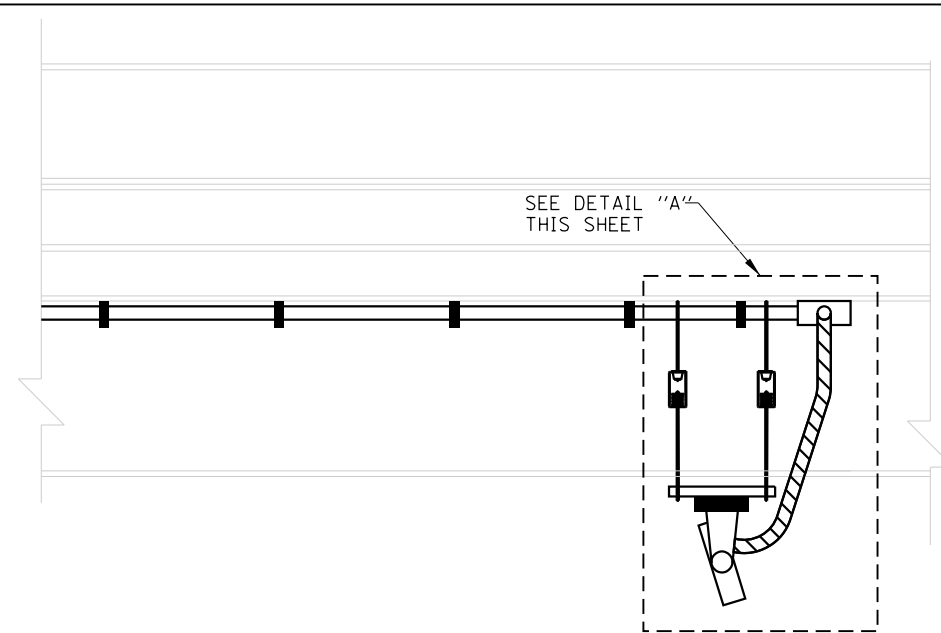
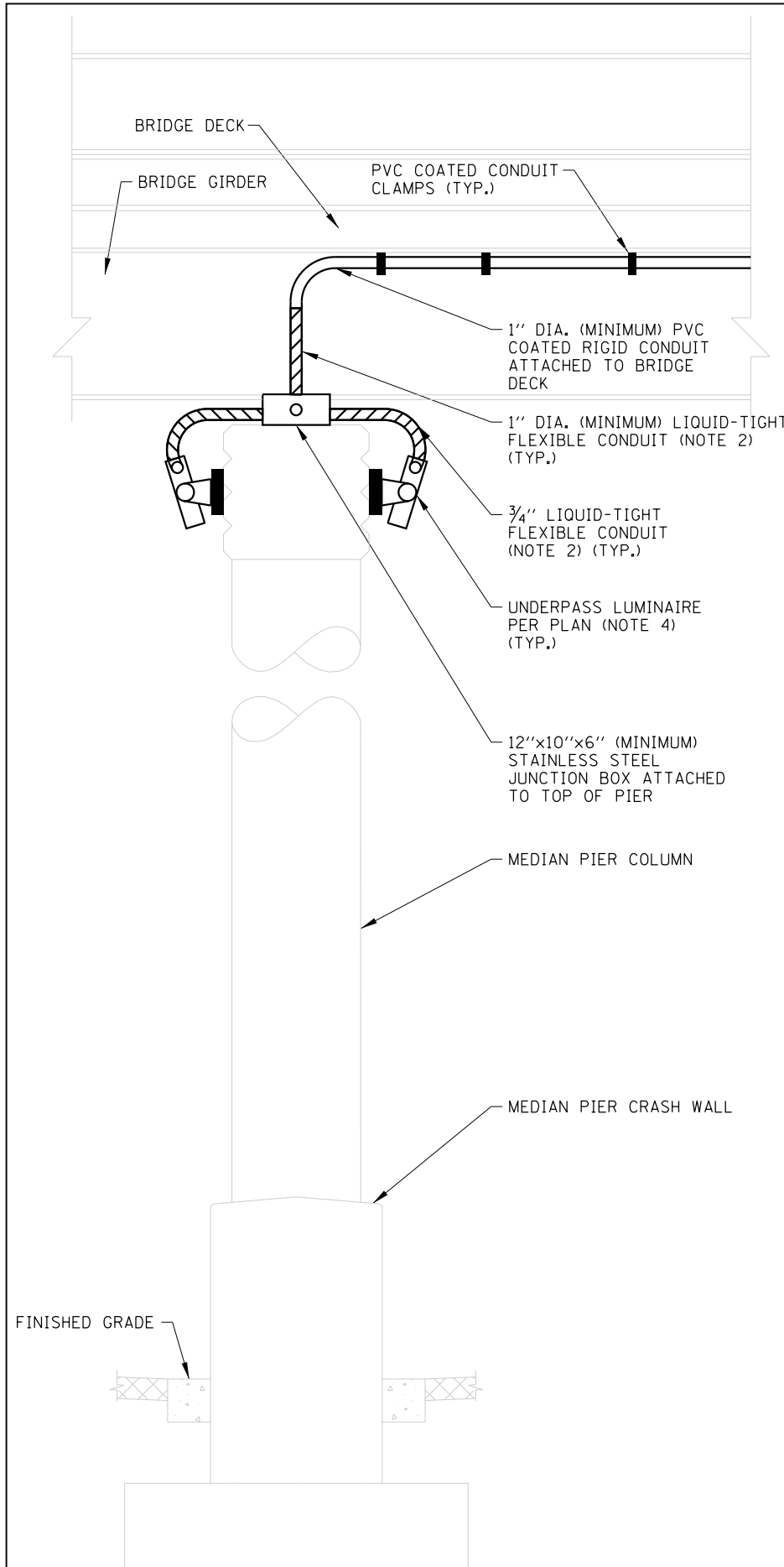

DETAIL A

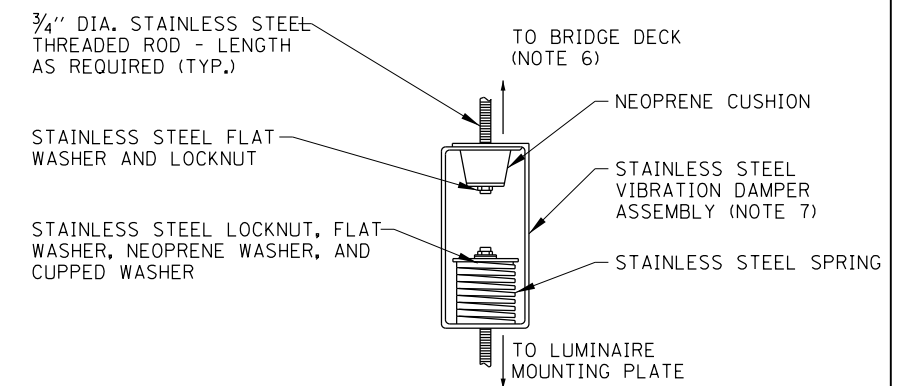
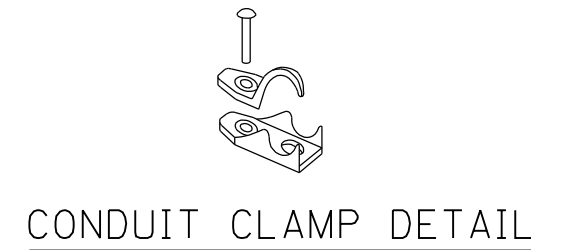

LUMINAIRE HANGER ASSEMBLY DETAIL

UNDERPASS LIGHTING  
(BRIDGE DECK SUSPENDED LUMINAIRE & MISCELLANEOUS DETAILS)

APPROVED *Paul Kovacs* CHIEF ENGINEER DATE 3-31-2016

NOTE:  
 FOR NOTES SEE SHEET 1 OF THIS SERIES.



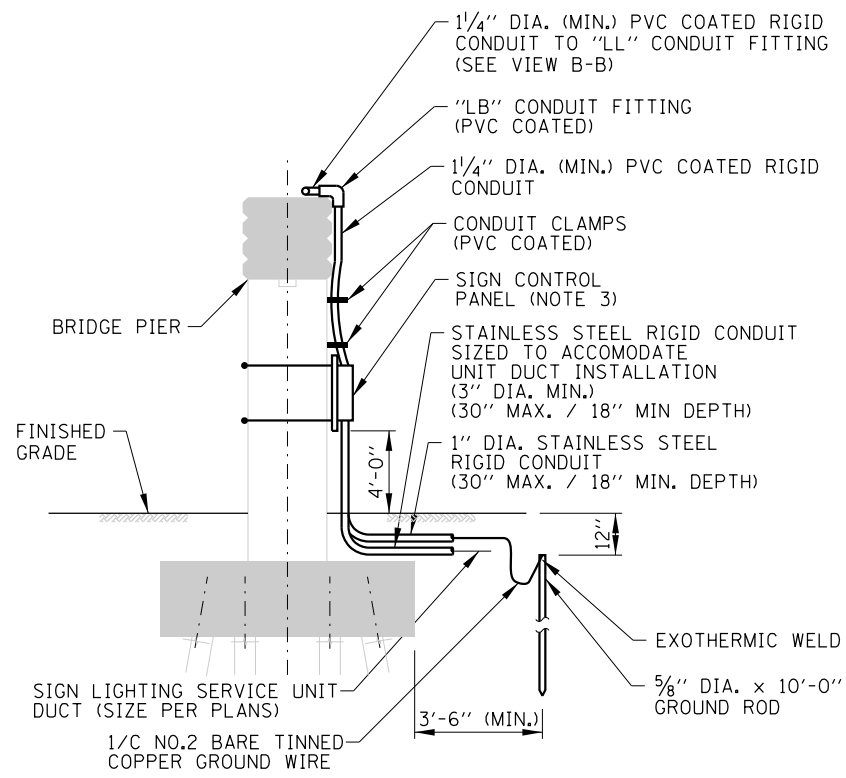

SECTION A-A

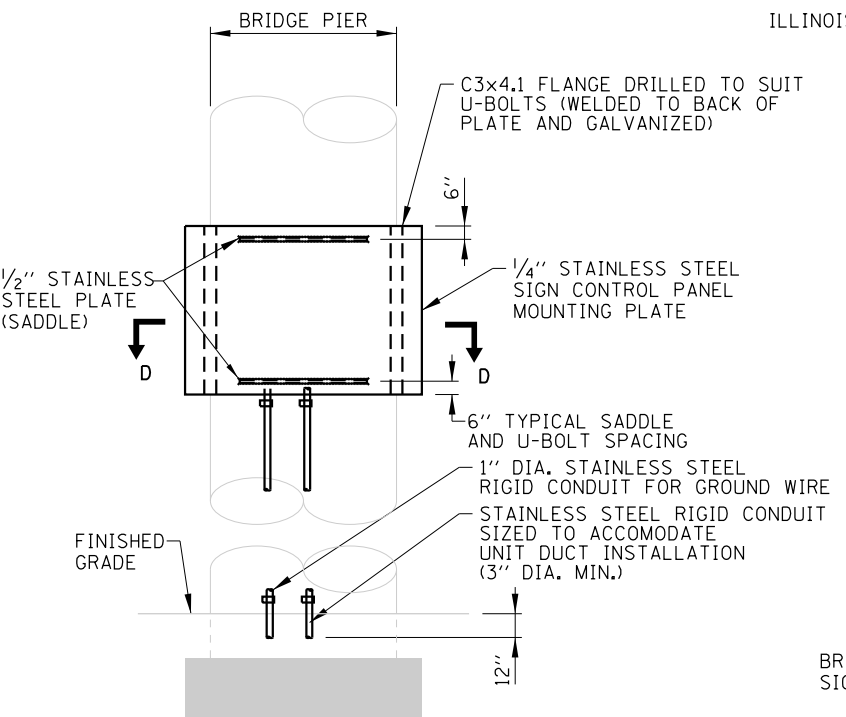

VIEW C-C

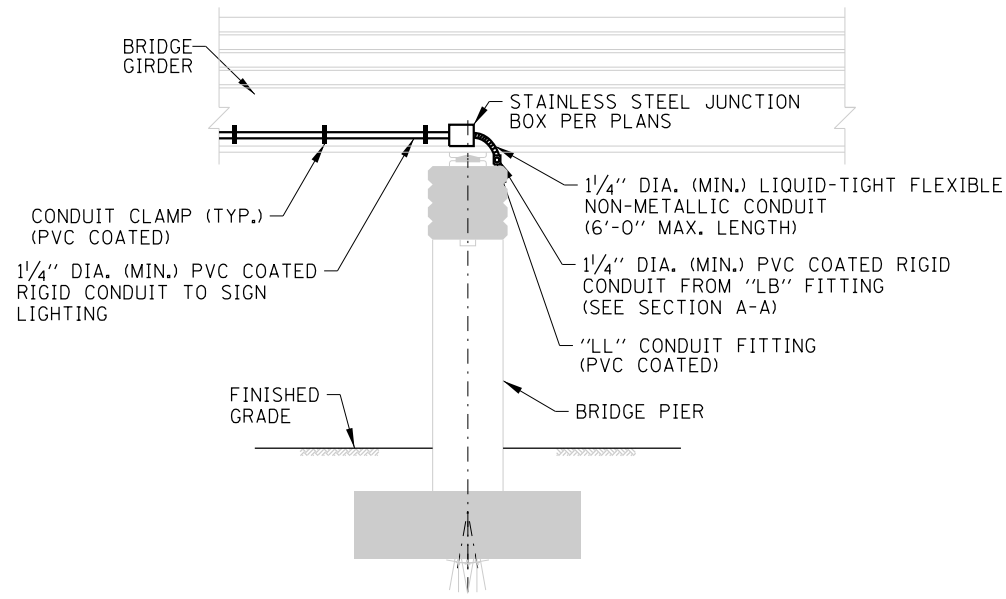

SECTION B-B

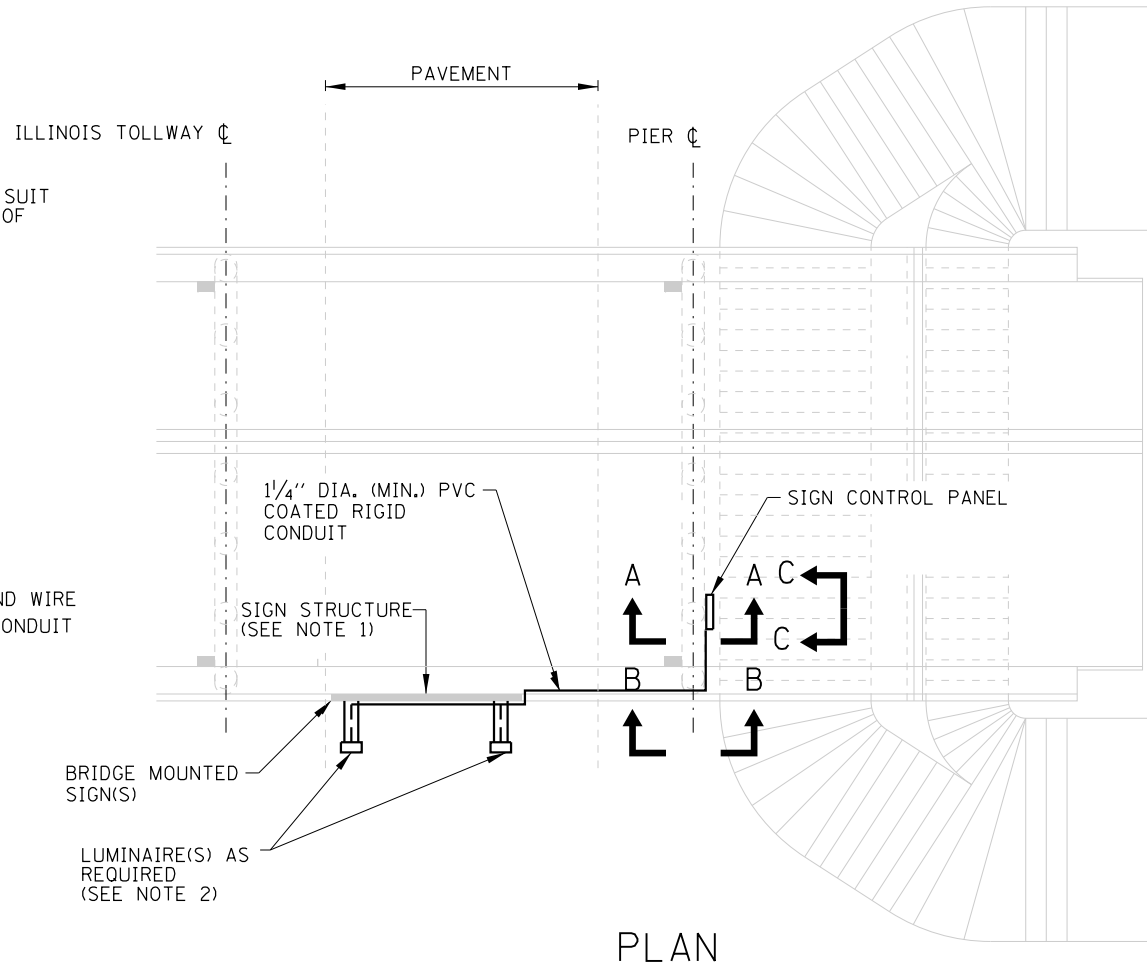

PLAN

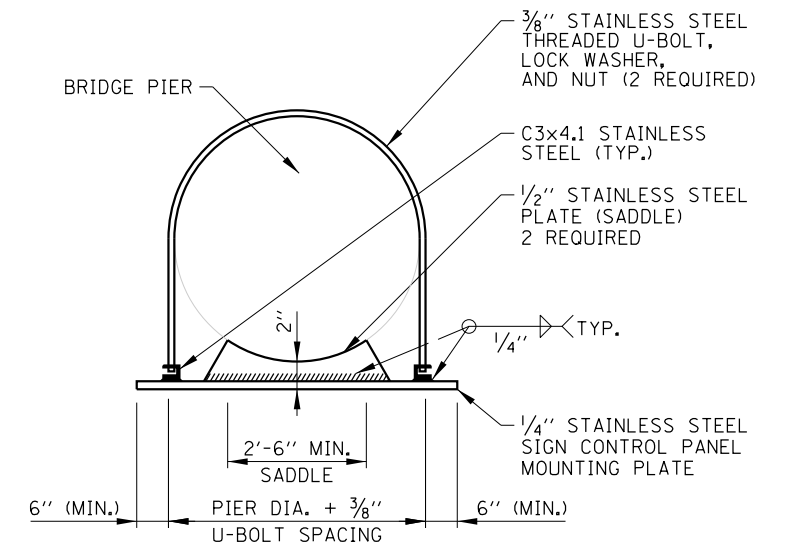

SECTION D-D

NOTES:

1. FOR SIGN STRUCTURE INSTALLATION DETAILS SEE SHEET 3 OF 3 IN THIS SERIES.
2. FOR SIGN LUMINAIRE INSTALLATION AND WIRING AND FOR INSTALLATION OF CONDUIT IN FIXTURE SUPPORT CHANNEL, SEE STANDARD H14.
3. FOR TYPICAL SIGN CONTROL PANEL DETAILS SEE SHEET 2 OF 3 IN THIS SERIES.
4. DETAILS SHOWN ON THIS SHEET ARE WITHOUT FLASHING BEACON. INSTALLATION OF FLASHING BEACON REQUIRES ADDITIONAL WORK AS SHOWN ON TYPICAL SIGN CONTROL PANEL DETAIL (SHEET 2 OF 3 IN THIS SERIES).
5. LUMINAIRE SUPPORT MEMBERS TO BE INSTALLED ONLY WHEN THE SIGN IS TO BE ILLUMINATED. MAINLINE TOLL PLAZA APPROACH SIGNS SHALL BE ILLUMINATED. DESIGNER TO DETERMINE REQUIREMENTS FOR LIGHTING ALL OTHER SIGNS BASED ON ROADWAY GEOMETRY.
6. PROVIDE 12" FLASHING BEACON ONLY WHERE INDICATED ON PLANS. FLASHING BEACON TO BE ATTACHED TO SUPPORT WITH STAINLESS STEEL SCREWS AND NEOPRENE SPACERS. DRILLED SCREW HOLES TO BE SEALED WATER-TIGHT.
7. SEE STRUCTURAL DRAWINGS FOR DETAILS OF SIGN SUPPORTS AND FIXTURE SUPPORT CHANNELS.
8. CONDUITS, CONDUIT FITTINGS, CLAMPS, AND APPURTENANCES ATTACHED TO ALUMINUM STRUCTURAL SUPPORTS SHALL BE PVC COATED ALUMINUM. PVC COATED GALVANIZED STEEL CONDUITS, CONDUIT FITTINGS, CLAMPS, AND APPURTENANCES SHALL BE UTILIZED WHERE ATTACHED TO STEEL STRUCTURAL SUPPORTS OR WHERE ATTACHED TO CONCRETE STRUCTURES UNLESS NOTED OTHERWISE HEREIN. THREADED JOINTS BETWEEN DISSIMILAR METALS SHALL BE COATED WITH AN APPROVED THREAD LUBRICANT.
9. ALL EQUIPMENT SHALL BE GROUNDED AND BONDED IN ACCORDANCE WITH THE NATIONAL ELECTRICAL CODE AND THE NATIONAL ELECTRICAL SAFETY CODE.

APPROVED. *Paul Kovacs*  
CHIEF ENGINEERING OFFICER DATE 2-7-2012.

BRIDGE MOUNTED SIGN LIGHTING  
(BRIDGE PIER MOUNTED FEEDER INSTALLATION)

DATE	REVISIONS
3-11-2015	REVISED CONDUITS TO STAINLESS STEEL.
3-01-2018	ADDED SURGE PROTECTION DEVICE.
3-01-2019	REVISED TO SHOW SINGLE SLOPE PARAPET.

SHEET 1 OF 3



BRIDGE MOUNT SIGN LIGHTING DETAILS

STANDARD H10-04



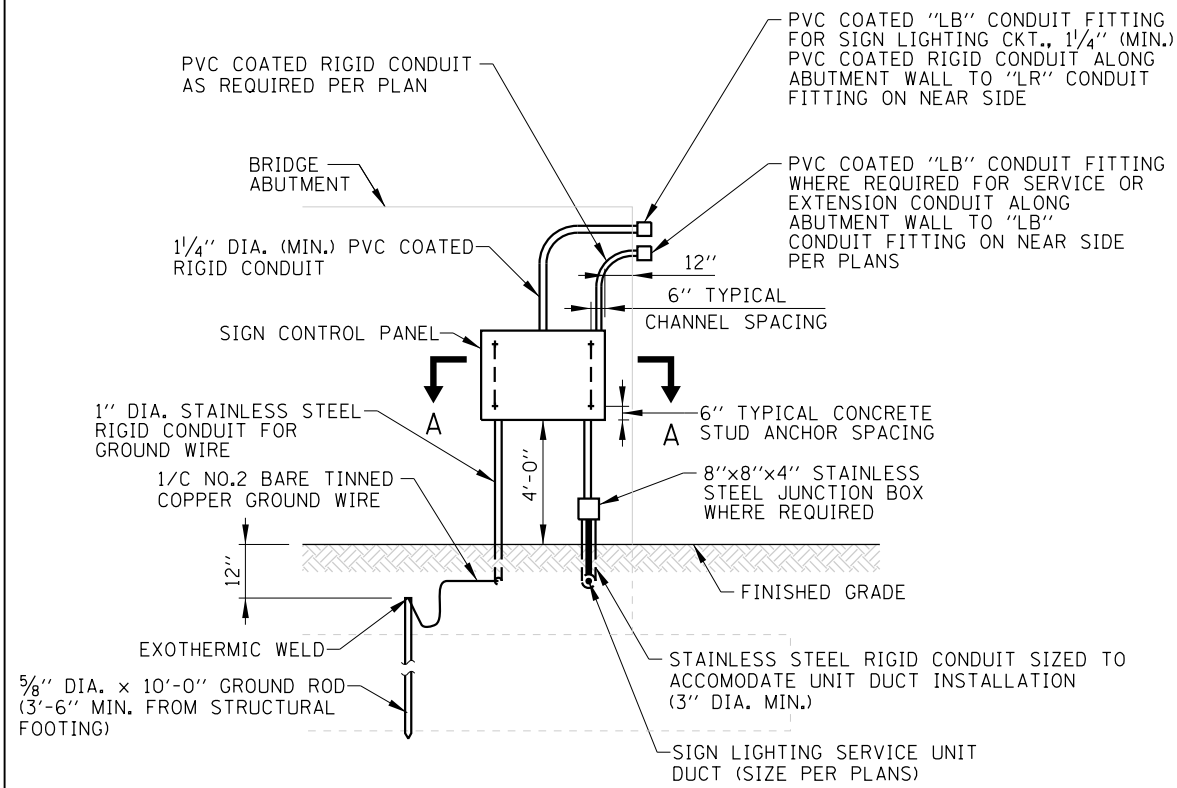

FAR SIDE ABUTMENT END ELEVATION

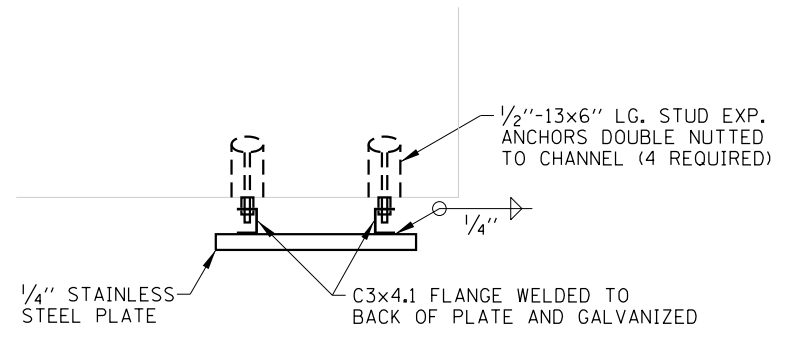

SECTION A-A

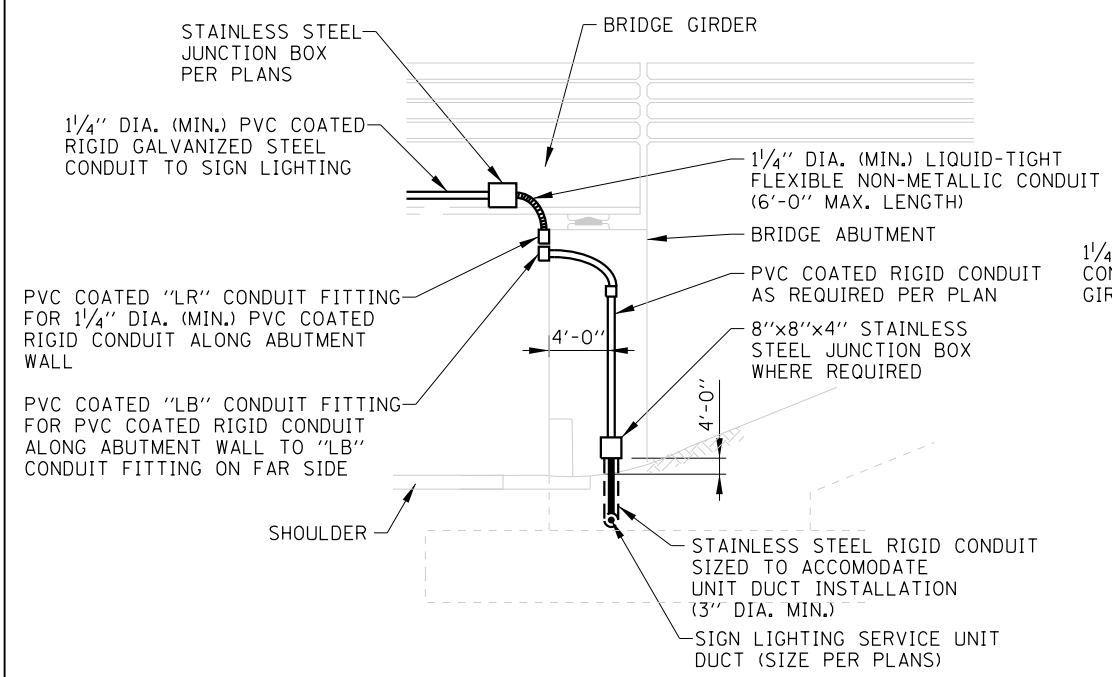

NEAR SIDE ABUTMENT END ELEVATION

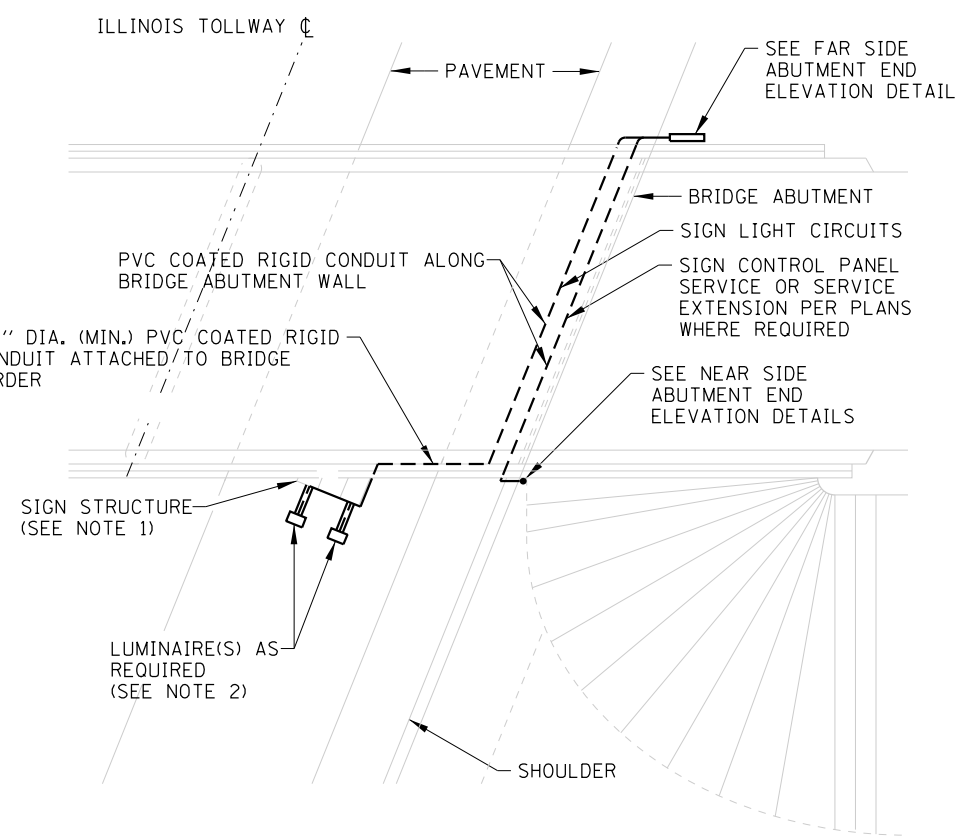

PLAN

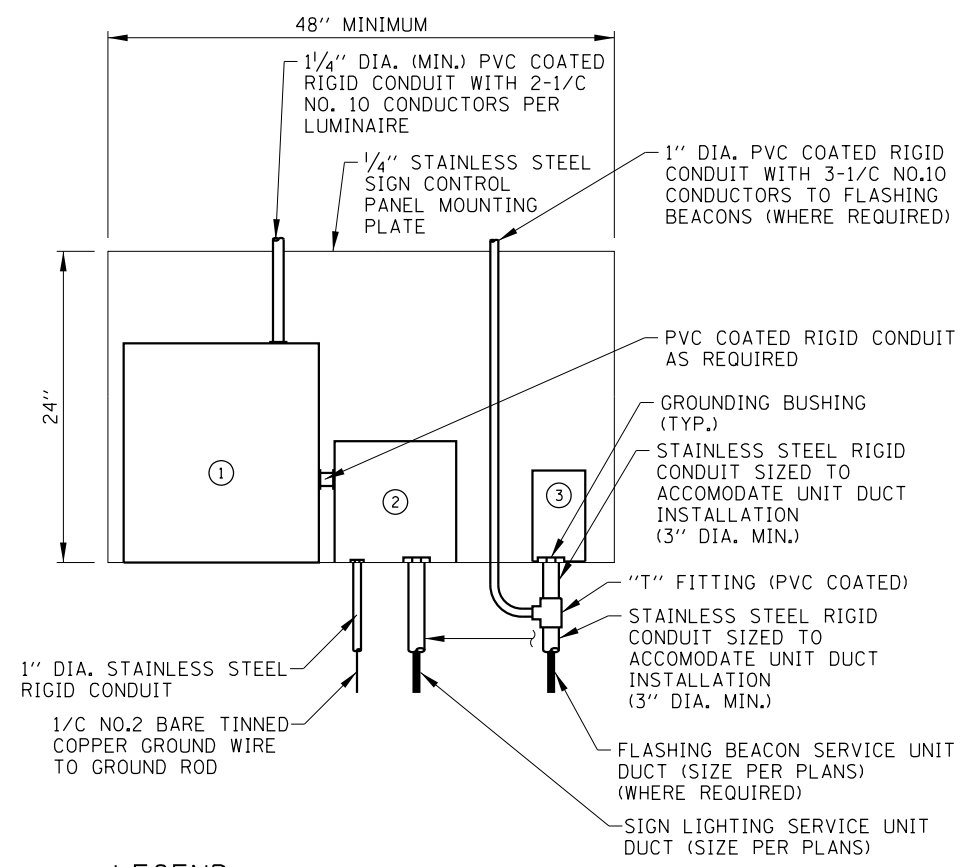

LEGEND:

- ① 18"x18"x8" STAINLESS STEEL JUNCTION BOX. PROVIDE SUFFICIENT 30 AMPERE, 600 VOLT TERMINAL BLOCKS TO SPLIT 480 VOLT WIRING FROM SIGN SERVICE CIRCUIT BREAKER TO TWO NO. 10 WIRES FOR EACH LUMINAIRE.
- ② SIGN LIGHTING SERVICE - CIRCUIT BREAKER (30 AMP/2 POLE) IN NEMA TYPE 4 C.I. ENCLOSURE, OZ TYPE "YW" WITH MOUNTING FEET OR APPROVED EQUAL. PROVIDE SURGE PROTECTION DEVICE (IN ACCORDANCE WITH ARTICLE 1065.02 OF THE STANDARD SPECIFICATIONS).
- ③ FLASHING BEACON CONTROLLER.

TYPICAL SIGN CONTROL PANEL DETAIL

(FOR TYPICAL WIRING DIAGRAM SEE STANDARD H14)

BRIDGE MOUNTED SIGN LIGHTING  
(BRIDGE ABUTMENT MOUNTED FEEDER INSTALLATION)

APPROVED: *Paul Kovacs*  
CHIEF ENGINEERING OFFICER DATE: 2-7-2012

NOTES:  
SEE SHEET 1 OF THIS SERIES FOR NOTES.

SHEET 2 OF 3

BRIDGE MOUNT SIGN LIGHTING DETAILS

STANDARD H10-04

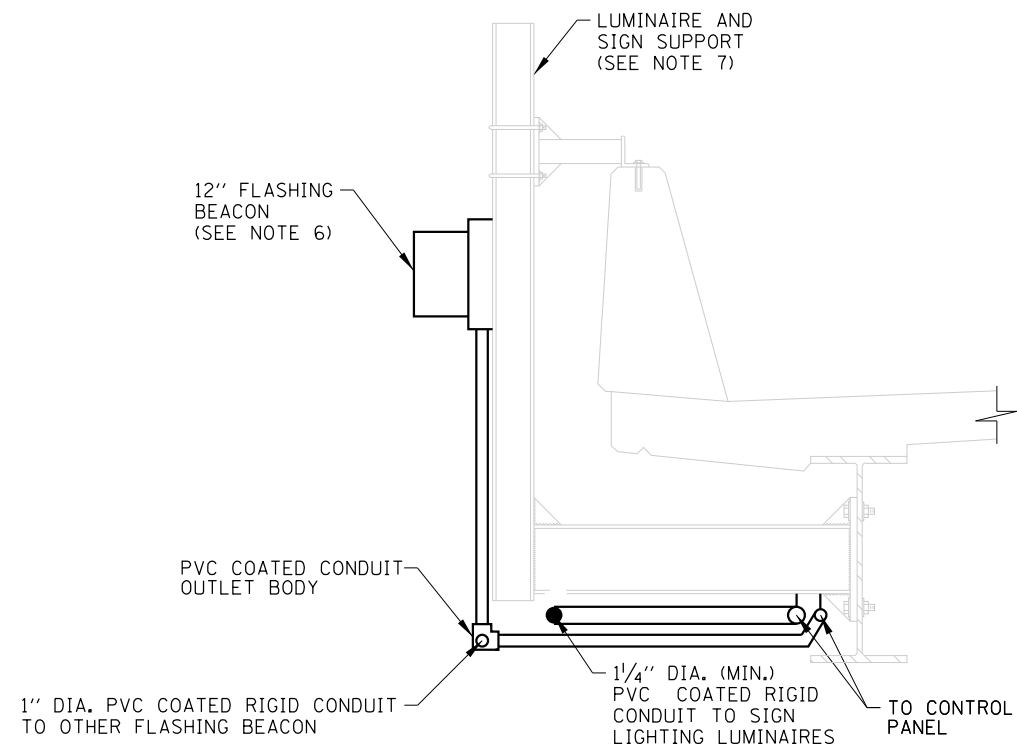

**SECTION A-A**  
(STEEL BRIDGE SHOWN)

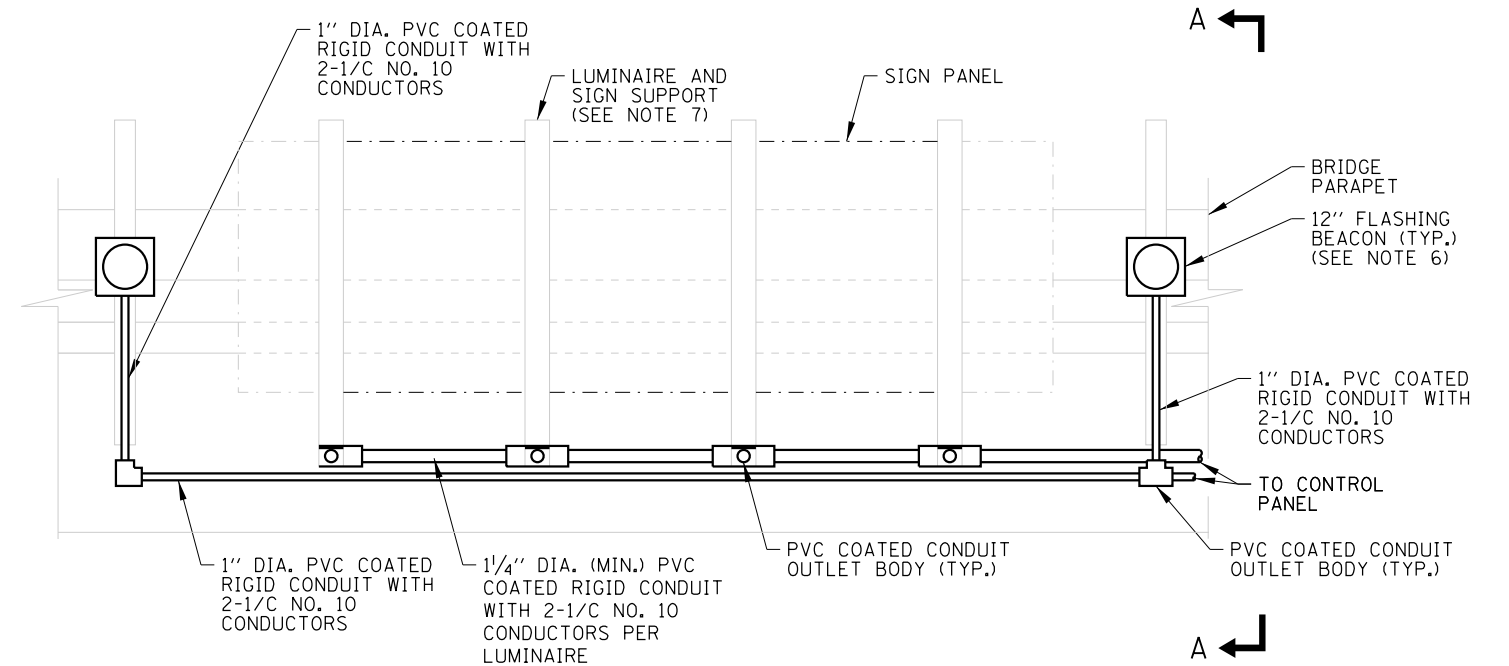

**TYPICAL FRONT ELEVATION WITH FLASHING BEACON**  
(LUMINAIRES NOT SHOWN FOR CLARITY)

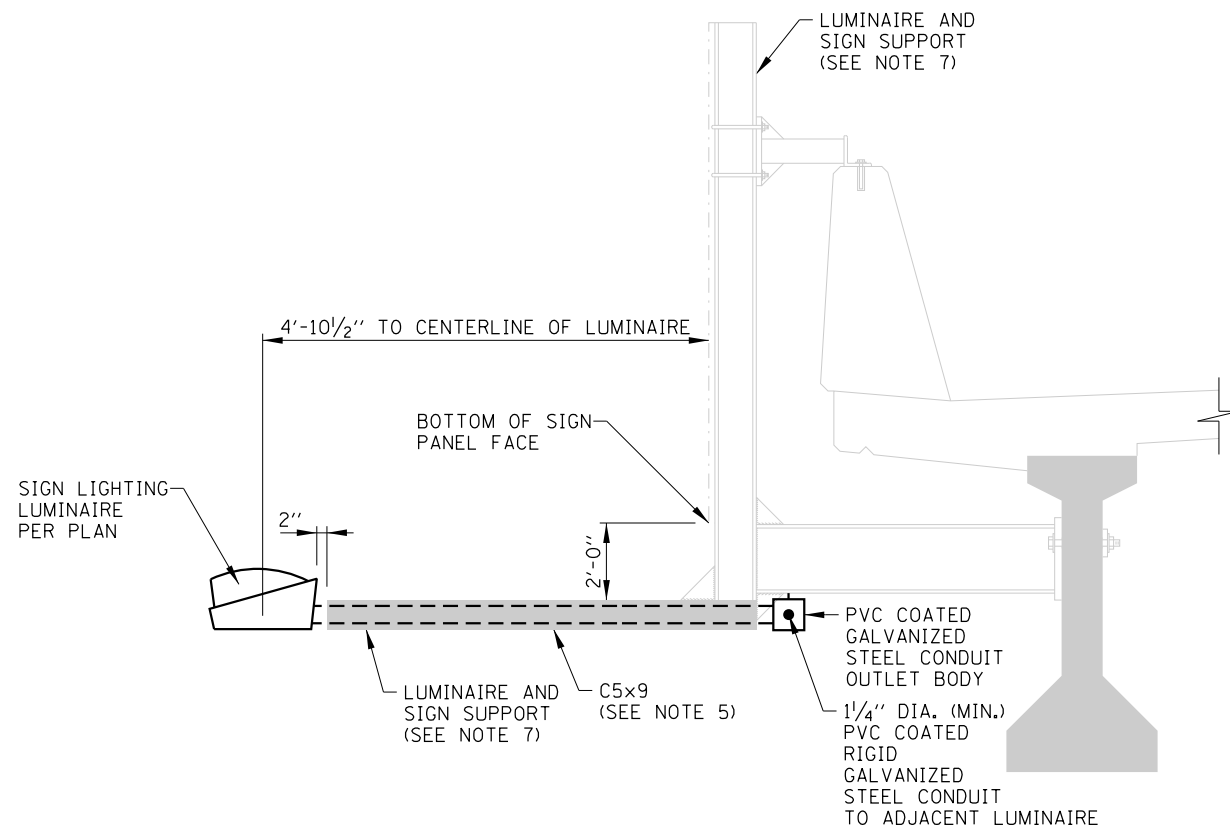

**SECTION B-B**  
(CONCRETE BRIDGE SHOWN)

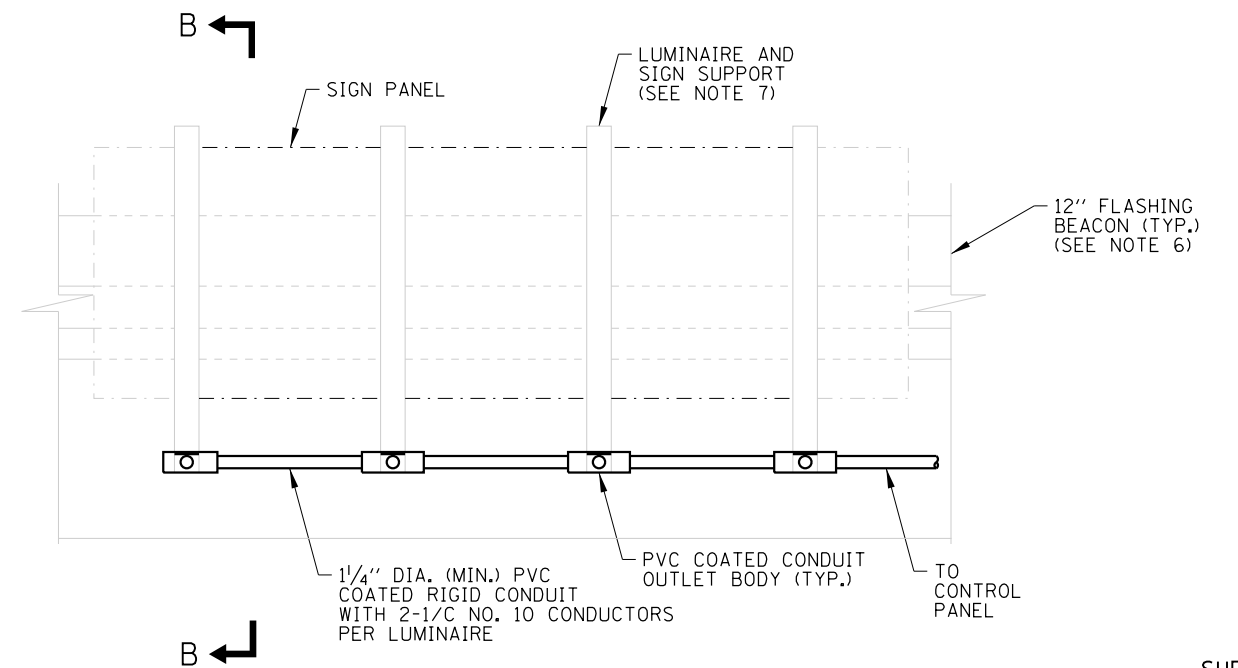

**TYPICAL FRONT ELEVATION WITHOUT FLASHING BEACON**  
(LUMINAIRES NOT SHOWN FOR CLARITY)

**BRIDGE MOUNTED SIGN LIGHTING  
(LUMINAIRE MOUNTING & CONDUIT DETAILS)**

APPROVED: *Paul Kovacs*  
CHIEF ENGINEERING OFFICER DATE: 2-7-2012

**NOTES:**  
SEE SHEET 1 OF THIS SERIES FOR NOTES.



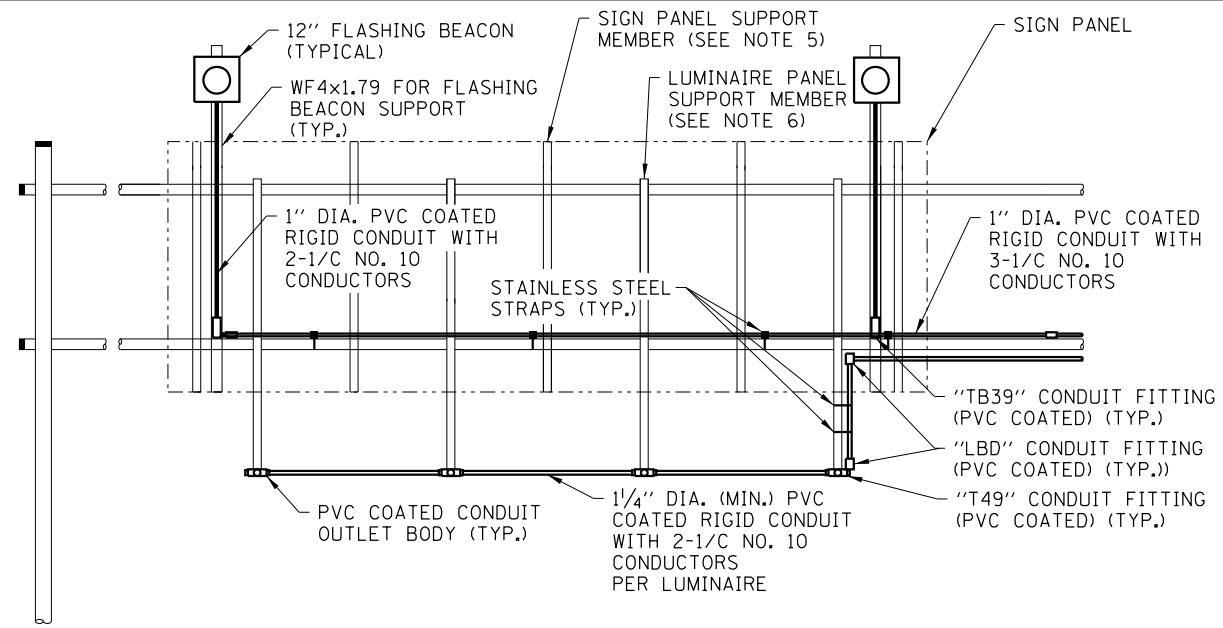

**FRONT ELEVATION WITH FLASHING BEACON**  
(LUMINAIRES NOT SHOWN FOR CLARITY)

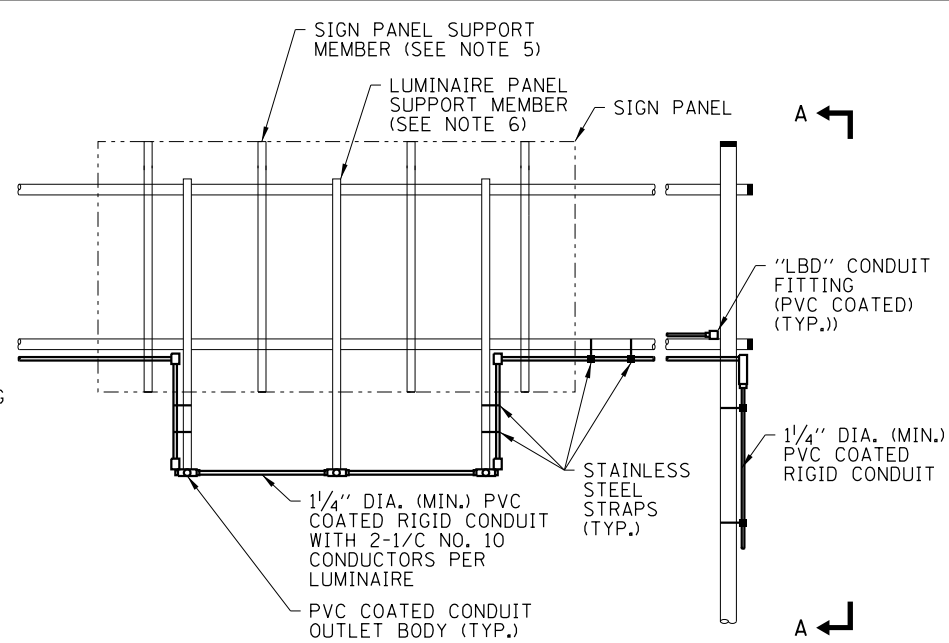

**FRONT ELEVATION WITHOUT FLASHING BEACON**  
(LUMINAIRES NOT SHOWN FOR CLARITY)

**NOTES:**

1. CONDUITS, CONDUIT FITTINGS, CLAMPS, AND APPURTENANCES ATTACHED TO ALUMINUM STRUCTURAL SUPPORTS SHALL BE PVC COATED ALUMINUM. PVC COATED GALVANIZED STEEL CONDUITS, CONDUIT FITTINGS, CLAMPS, AND APPURTENANCES SHALL BE UTILIZED WHERE ATTACHED TO STEEL STRUCTURAL SUPPORTS OR WHERE ATTACHED TO CONCRETE STRUCTURES UNLESS NOTED OTHERWISE HEREIN. THREADED JOINTS BETWEEN DISSIMILAR METALS SHALL BE COATED WITH AN APPROVED THREAD LUBRICANT.
2. PROVIDE 12" FLASHING BEACON ONLY WHERE INDICATED ON PLANS. FLASHING BEACON TO BE ATTACHED TO SUPPORT WITH STAINLESS STEEL SCREWS AND NEOPRENE SPACERS. DRILLED SCREW HOLES TO BE SEALED WATER-TIGHT.
3. ALL EQUIPMENT SHALL BE GROUNDED AND BONDED IN ACCORDANCE WITH THE NATIONAL ELECTRICAL CODE AND THE NATIONAL ELECTRICAL SAFETY CODE.
4. ALL STEEL TO BE HOT DIPPED GALVANIZED AFTER WELDING PER ILLINOIS TOLLWAY SUPPLEMENTAL SPECIFICATION SECTION 733.
5. SEE STRUCTURAL DRAWINGS FOR DETAILS OF SIGN SUPPORTS AND FIXTURE SUPPORT CHANNELS.
6. LUMINAIRE SUPPORT MEMBERS TO BE INSTALLED ONLY WHEN STRUCTURE IS TO BE ILLUMINATED. MAINLINE PLAZA APPROACH SIGNS SHALL BE ILLUMINATED.
7. FOR SIGN LUMINAIRE INSTALLATION AND WIRING AND FOR INSTALLATION OF CONDUIT IN FIXTURE SUPPORT CHANNEL, SEE STANDARD H14.

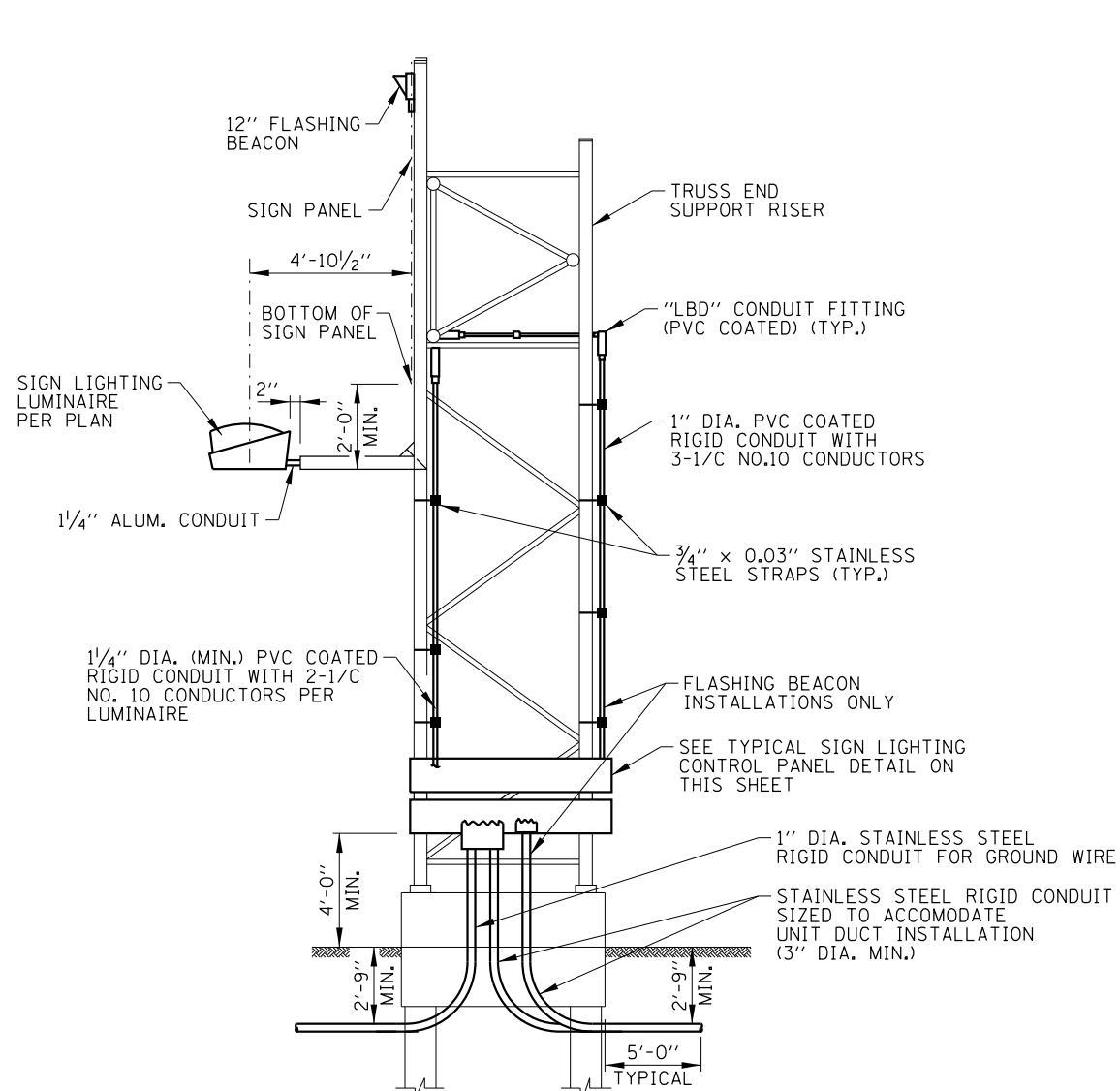

**SECTION A-A**  
**FULL ELEVATION (OUTSIDE FOUNDATION)**

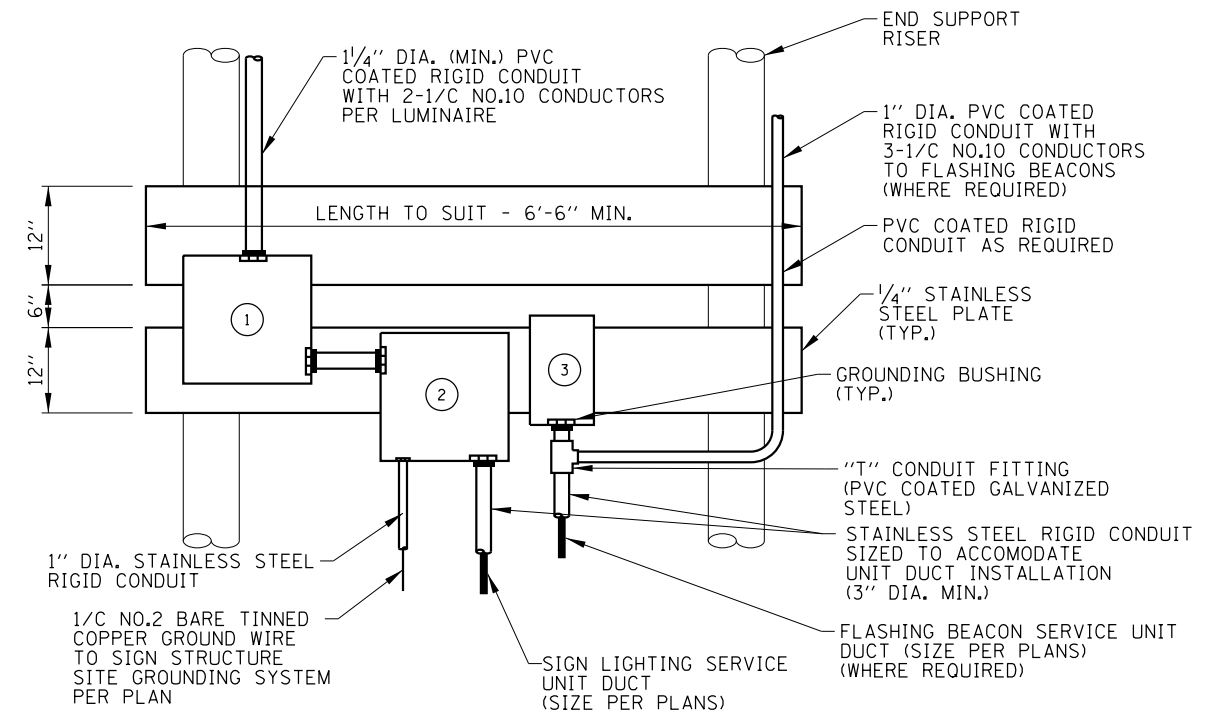

**LEGEND:**

- ① 18"x18"x8" STAINLESS STEEL JUNCTION BOX. PROVIDE SUFFICIENT 30 AMPERE, 600 VOLT TERMINAL BLOCKS TO SPLIT 480 VOLT WIRING FROM SIGN SERVICE CIRCUIT BREAKER TO TWO NO. 10 WIRES FOREACH LUMINAIRE.
- ② SIGN LIGHTING SERVICE - CIRCUIT BREAKER (30 AMP/2 POLE) IN NEMA TYPE 4 STAINLESS STEEL TYPE 316 WITH MOUNTING FEET OR APPROVED EQUAL. PROVIDE SURGE PROTECTION DEVICE (IN ACCORDANCE WITH ARTICLE 1065.02 OF THE STANDARD SPECIFICATIONS).
- ③ FLASHING BEACON CONTROLLER.

**TYPICAL SIGN LIGHTING CONTROL PANEL**

(FOR TYPICAL WIRING DIAGRAM SEE STANDARD H14)

DATE	REVISIONS
3-31-2014	REVISED FOUNDATION.
3-11-2015	REVISED CONDUIT MATERIALS
3-11-2015	REVISED CONDUIT MATERIALS
3-01-2018	ADDED SURGE PROTECTIVE DEVICE
3-01-2019	STAINLESS STEEL SERVICE JUNCTION BOX



SPAN TYPE STRUCTURE  
SIGN LIGHTING DETAILS

STANDARD H11-05

APPROVED: *Paul Kovacs*  
CHIEF ENGINEERING OFFICER DATE: 2-7-2012.

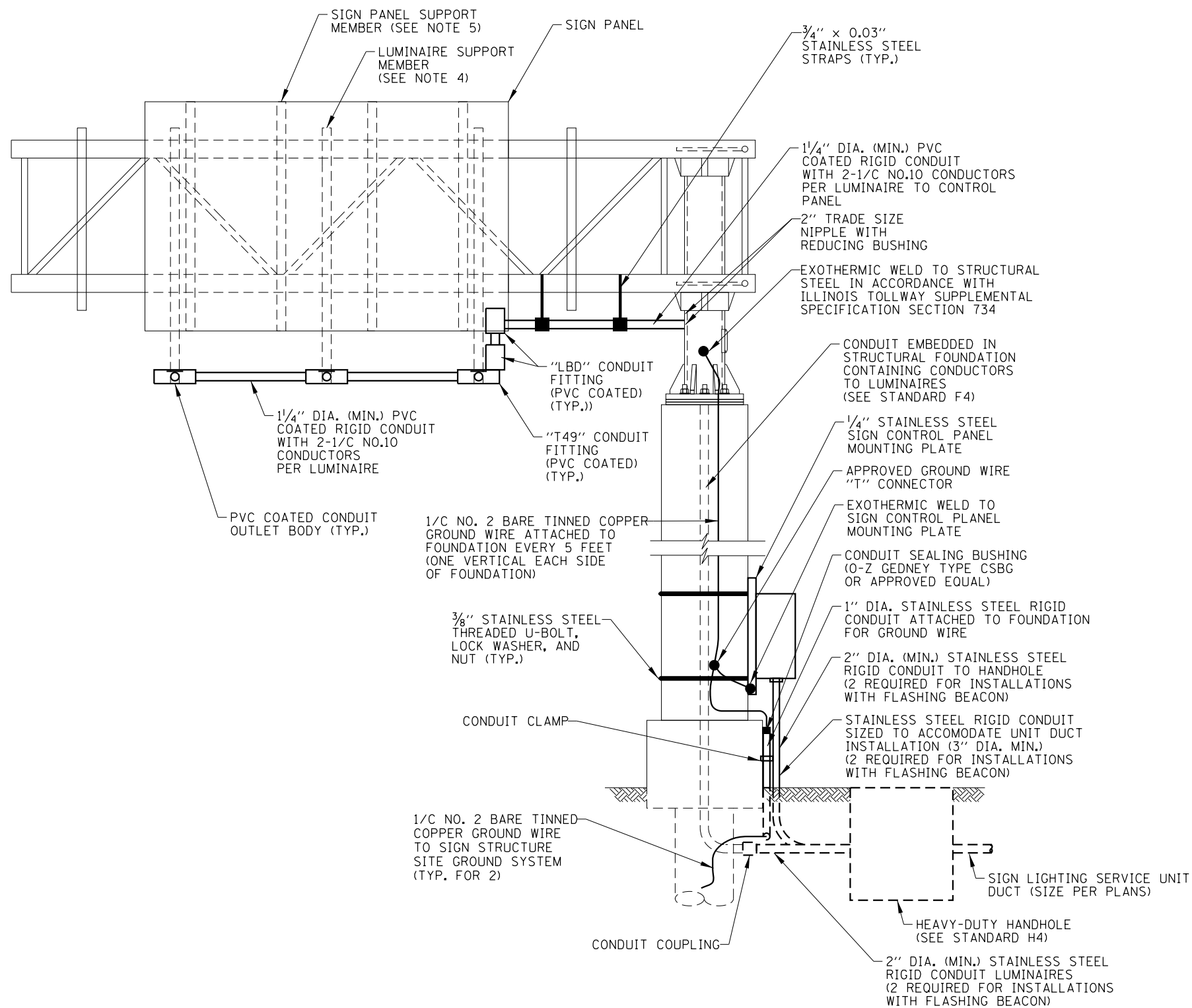

TYPICAL FRONT ELEVATION WITH FLASHING BEACON  
(LUMINAIRES NOT SHOWN FOR CLARITY)

**NOTES:**

1. A GROUND WIRE (NO. 12 AWG.) WILL BE RUN FROM THE GROUNDING BUSHING (OVERHEAD SUPPORT) TO THE GROUNDING BUSHING IN THE JUNCTION BOX.
2. ALL EQUIPMENT SHALL BE GROUNDED AND BONDED IN ACCORDANCE WITH THE NATIONAL ELECTRICAL CODE AND THE NATIONAL ELECTRICAL SAFETY CODE.
3. CONDUITS, CONDUIT FITTINGS, CLAMPS, AND APPURTENANCES ATTACHED TO ALUMINUM STRUCTURAL SUPPORTS SHALL BE PVC COATED ALUMINUM. PVC COATED GALVANIZED STEEL CONDUITS, CONDUIT FITTINGS, CLAMPS, AND APPURTENANCES SHALL BE UTILIZED WHERE ATTACHED TO STEEL STRUCTURAL SUPPORTS OR WHERE ATTACHED TO CONCRETE STRUCTURES UNLESS NOTED OTHERWISE HEREIN. THREADED JOINTS BETWEEN DISSIMILAR METALS SHALL BE COATED WITH AN APPROVED THREAD LUBRICANT.
4. LUMINAIRE SUPPORT MEMBERS TO BE INSTALLED ONLY WHEN THE SIGN IS TO BE ILLUMINATED. MAINLINE TOLL PLAZA APPROACH SIGNS SHALL BE ILLUMINATED.
5. SEE STRUCTURAL DRAWINGS FOR DETAILS OF SIGN SUPPORTS AND FIXTURE SUPPORT CHANNELS.
6. FOR SIGN LUMINAIRE INSTALLATION AND WIRING AND FOR INSTALLATION OF CONDUIT IN FIXTURE SUPPORT CHANNEL, SEE STANDARD H14.
7. ALL STEEL TO BE HOT DIPPED GALVANIZED AFTER WELDING PER ILLINOIS TOLLWAY SUPPLEMENTAL SPECIFICATION SECTION 733.
8. PROVIDE 12" FLASHING BEACON ONLY WHERE INDICATED ON PLANS. FLASHING BEACON TO BE ATTACHED TO SUPPORT WITH STAINLESS STEEL SCREWS AND NEOPRENE SPACERS. DRILLED SCREW HOLES TO BE SEALED WATERTIGHT.



APPROVED: *Paul Kovacs*  
CHIEF ENGINEERING OFFICER DATE: 2-7-2012.

DATE	REVISIONS
2-07-2012	ADDED SIGN POST SUPPORT MEMBERS, REVISED NOTES, REMOVED CANISTER BALLAST AND ADDED JUNCTION BOX.
3-11-2015	REVISED CONDUITS TO STAINLESS STEEL.
3-01-2018	ADDED SURGE PROTECTION DEVICE.

CANTILEVER STRUCTURE  
SIGN LIGHTING DETAILS

STANDARD H12-04

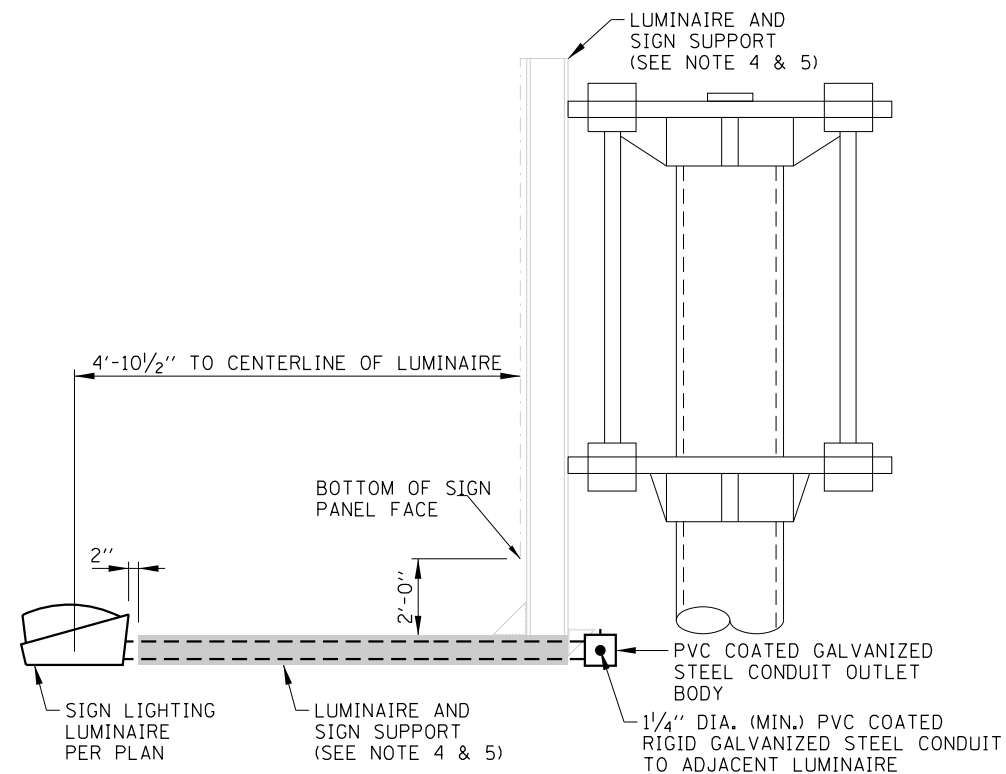

## SIGN LUMINAIRE INSTALLATION

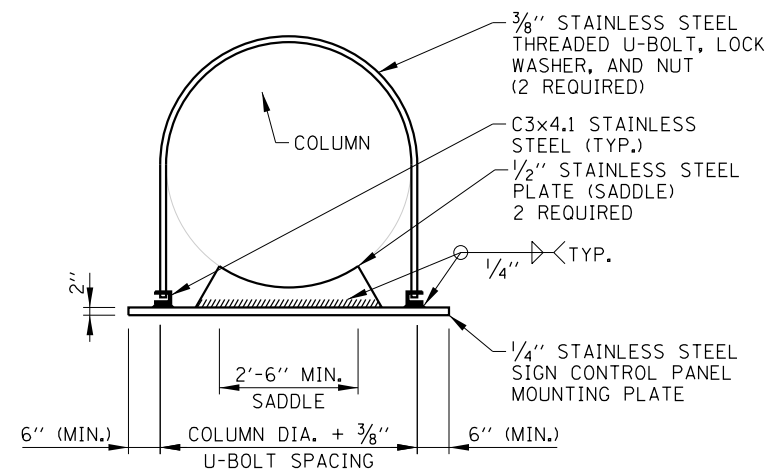

### SECTION A-A

(CONTROL EQUIPMENT NOT SHOWN FOR CLARITY)

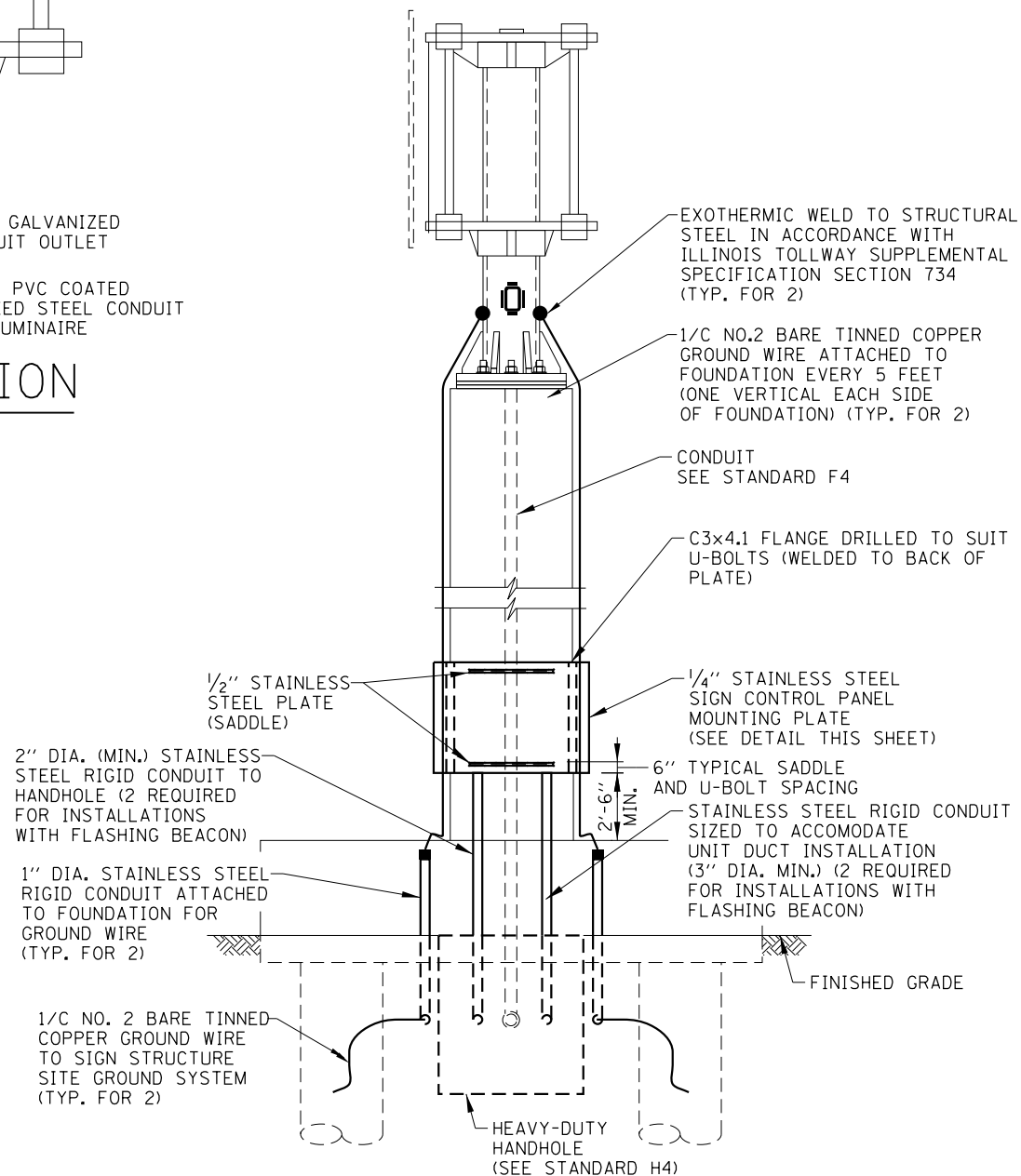

## TYPICAL SIDE ELEVATION

(LUMINAIRES NOT SHOWN FOR CLARITY)

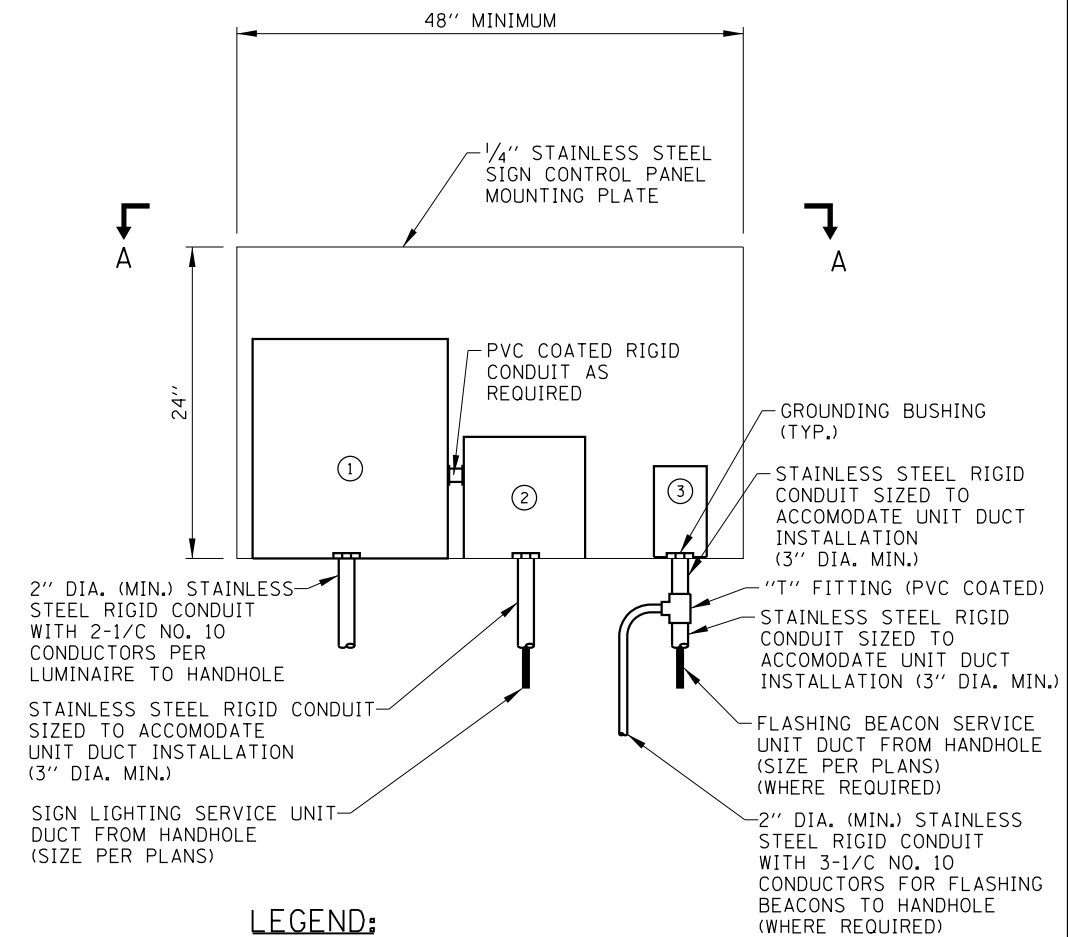

### LEGEND:

- ① 18"x18"x8" STAINLESS STEEL JUNCTION BOX. PROVIDE SUFFICIENT 30 AMPERE, 600 VOLT TERMINAL BLOCKS TO SPLIT 480 VOLT WIRING FROM SIGN SERVICE CIRCUIT BREAKER TO TWO NO. 10 WIRES FOR EACH LUMINAIRE.
- ② SIGN LIGHTING SERVICE - CIRCUIT BREAKER (30 AMP/2 POLE) IN NEMA TYPE 4 C.I. ENCLOSURE, OZ TYPE "YW" WITH MOUNTING FEET OR APPROVED EQUAL. PROVIDE SURGE PROTECTION DEVICE (IN ACCORDANCE WITH ARTICLE 1065.02 OF THE STANDARD SPECIFICATIONS).
- ③ FLASHING BEACON CONTROLLER.

## TYPICAL SIGN CONTROL PANEL DETAIL

(FOR TYPICAL WIRING DIAGRAM SEE STANDARD H14)

APPROVED. *Paul Kovacs* CHIEF ENGINEERING OFFICER DATE: 2-7-2012.

NOTES:  
SEE SHEET 1 OF THIS SERIES FOR NOTES.

SHEET 2 OF 2



CANTILEVER STRUCTURE  
SIGN LIGHTING DETAILS

STANDARD H12-04

RESERVED

APPROVED..... CHIEF ENGINEER ..... DATE .....

DATE	REVISIONS

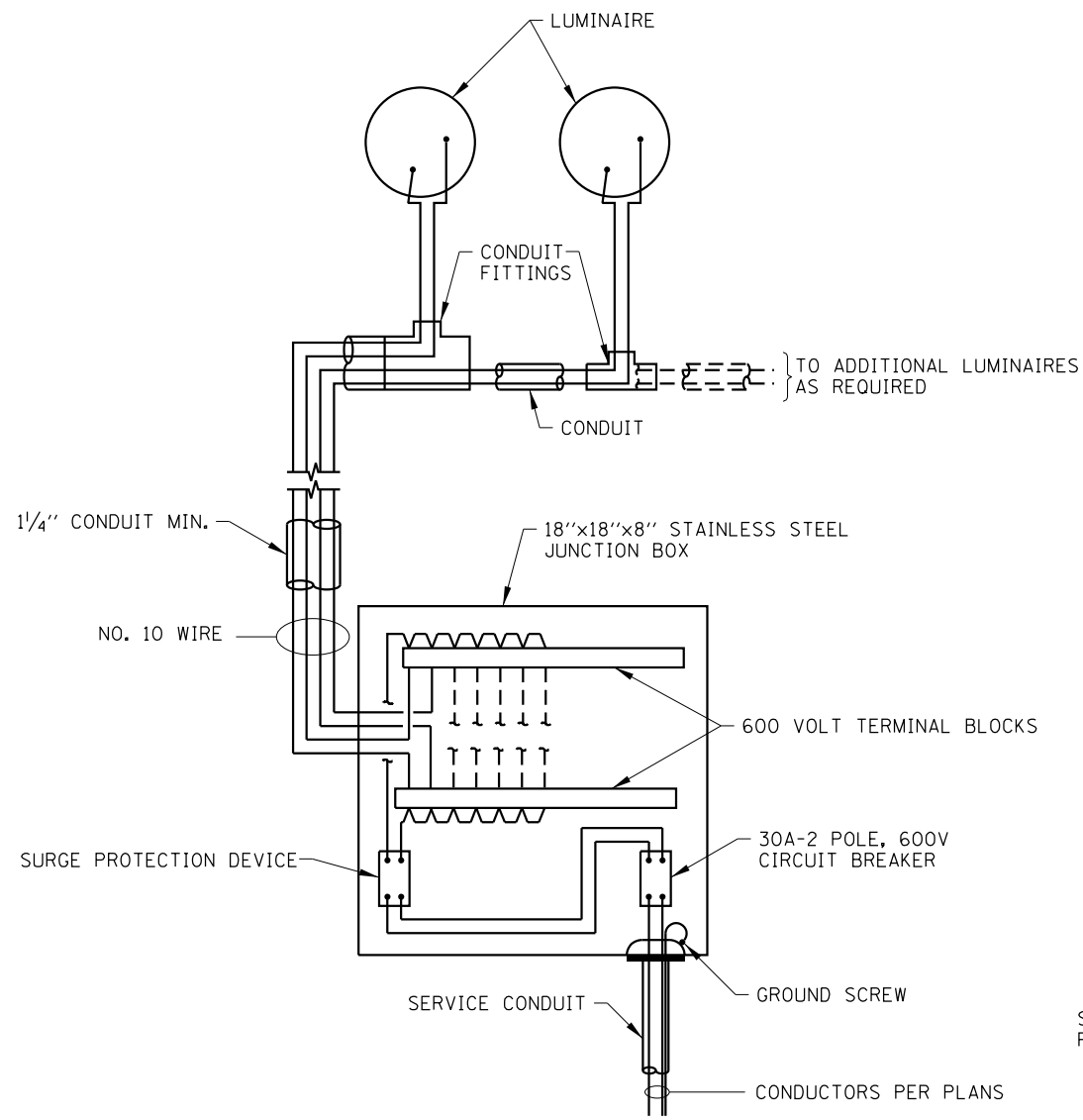

RESERVED
STANDARD H13

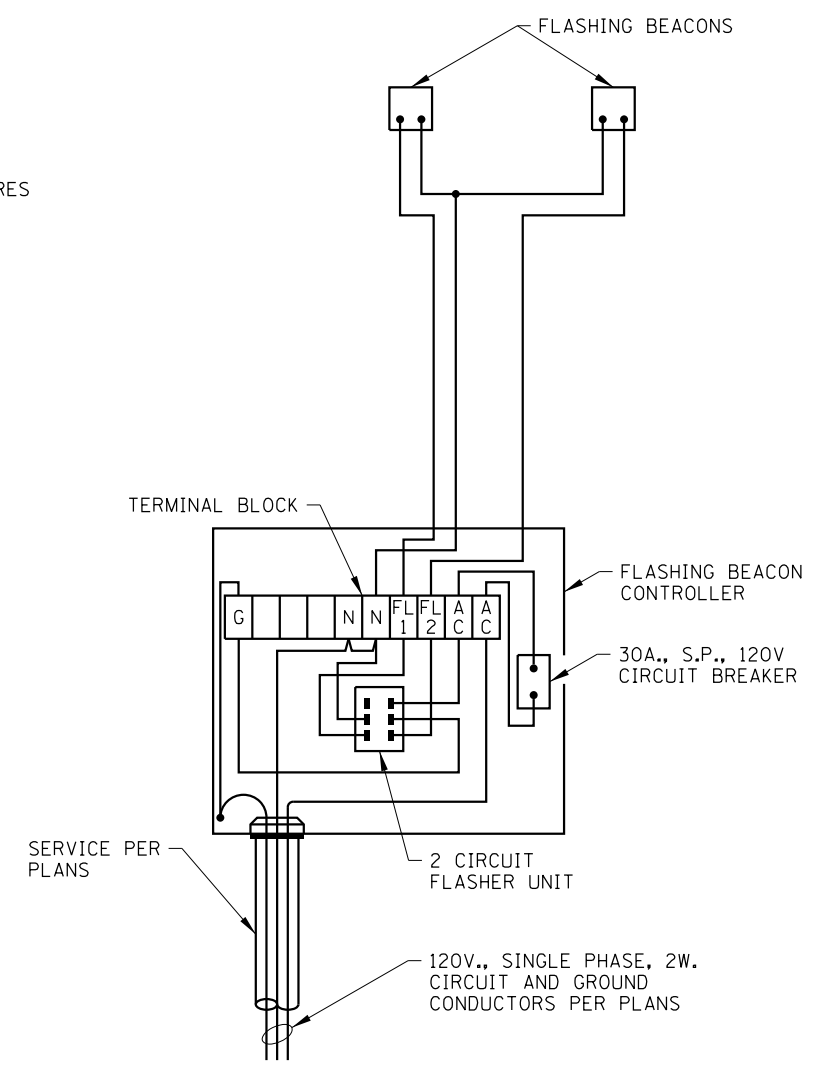

**SIGN WIRING DIAGRAM**  
NO SCALE

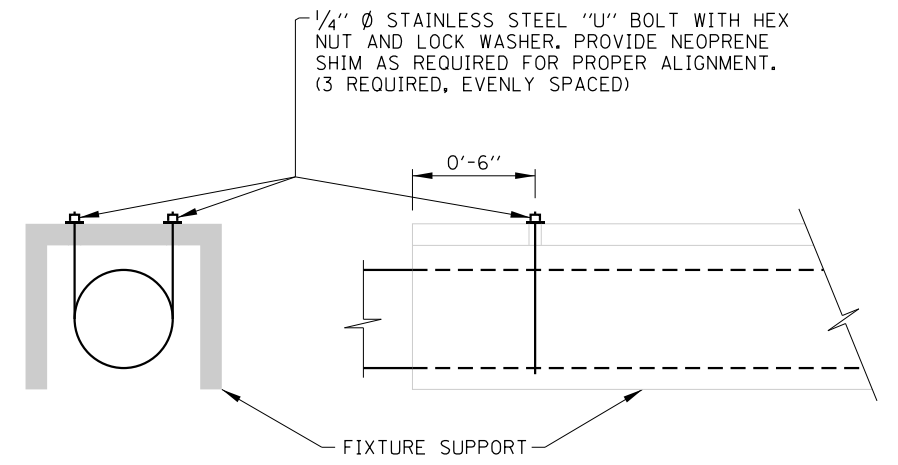

**FLASHING BEACON WIRING DIAGRAM**  
NO SCALE



**LUMINAIRE SUPPORT DETAIL**  
NO SCALE

**NOTES:**

1. SEE STRUCTURAL DRAWINGS FOR DETAILS OF SIGN SUPPORTS AND FIXTURE SUPPORT CHANNELS.
2. CONDUITS, CONDUIT FITTINGS, CLAMPS, AND APPURTENANCES ATTACHED TO ALUMINUM STRUCTURAL SUPPORTS SHALL BE PVC COATED ALUMINUM. PVC COATED GALVANIZED STEEL CONDUITS, CONDUIT FITTINGS, CLAMPS, AND APPURTENANCES SHALL BE UTILIZED WHERE ATTACHED TO STEEL STRUCTURAL SUPPORTS OR WHERE ATTACHED TO CONCRETE STRUCTURES UNLESS NOTED OTHERWISE HEREIN. THREADED JOINTS BETWEEN DISSIMILAR METALS SHALL BE COATED WITH AN APPROVED THREAD LUBRICANT.
3. ALL EQUIPMENT SHALL BE GROUNDED AND BONDED IN ACCORDANCE WITH THE NATIONAL ELECTRICAL CODE AND THE NATIONAL ELECTRICAL SAFETY CODE.
4. INSTALL SURGE PROTECTION DEVICE IN ACCORDANCE WITH ARTICLE 1065.02 OF THE SUPPLEMENTAL SPECIFICATIONS.

*Paul Kovacs*  
APPROVED, CHIEF ENGINEERING OFFICER DATE 2-7-2012.

DATE	REVISIONS
2-07-2012	REMOVED CANISTER BALLASTS, NEW JUNCTION BOX AND TERMINAL BLOCKS
3-11-2015	REVISED NOTES
3-01-2018	TYPOGRAPHICAL CORRECTIONS.
3-1-2020	REVISED NOTES



SIGN LUMINAIRE MOUNTING DETAIL AND WIRING DIAGRAMS  
STANDARD H14-04

RESERVED

APPROVED..... CHIEF ENGINEER..... DATE .....

DATE	REVISIONS



RESERVED
STANDARD H15

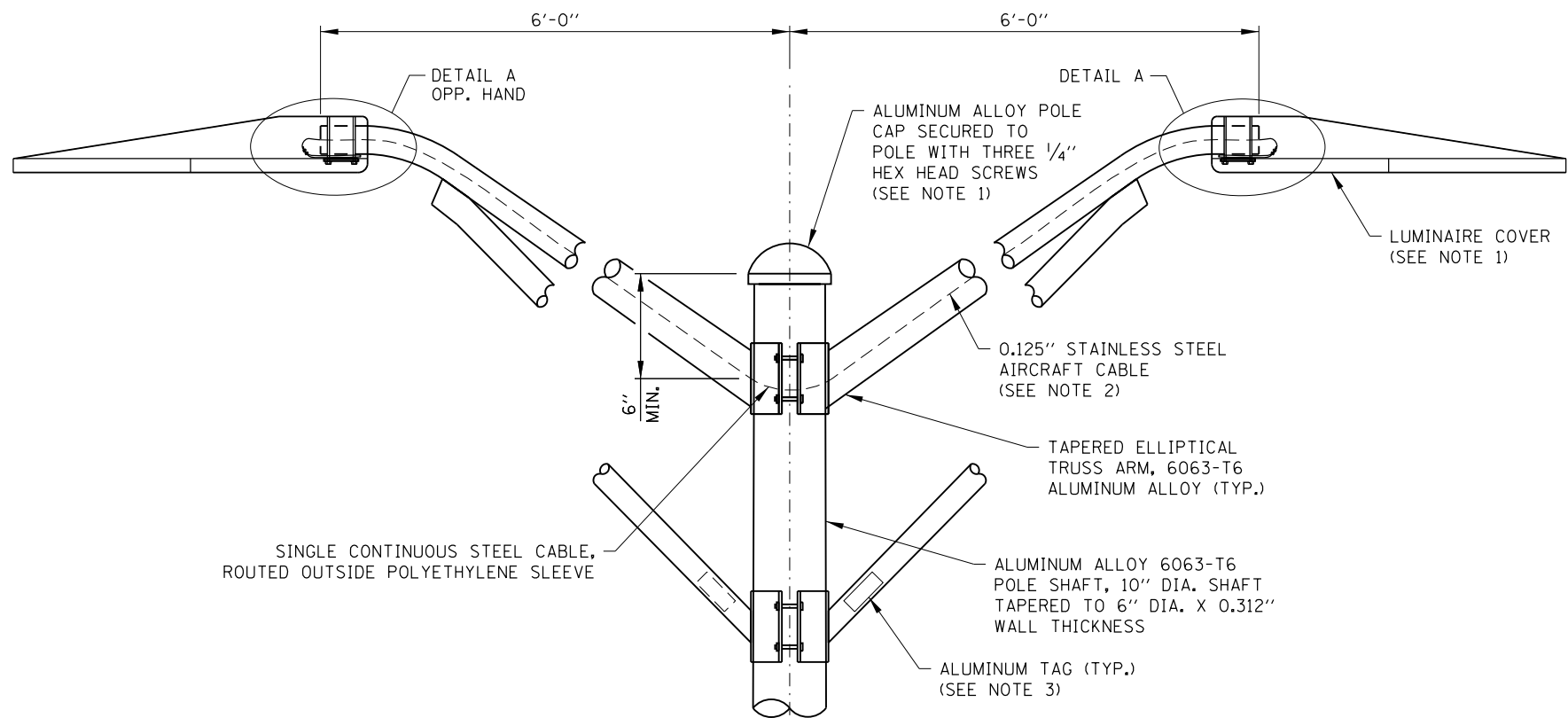

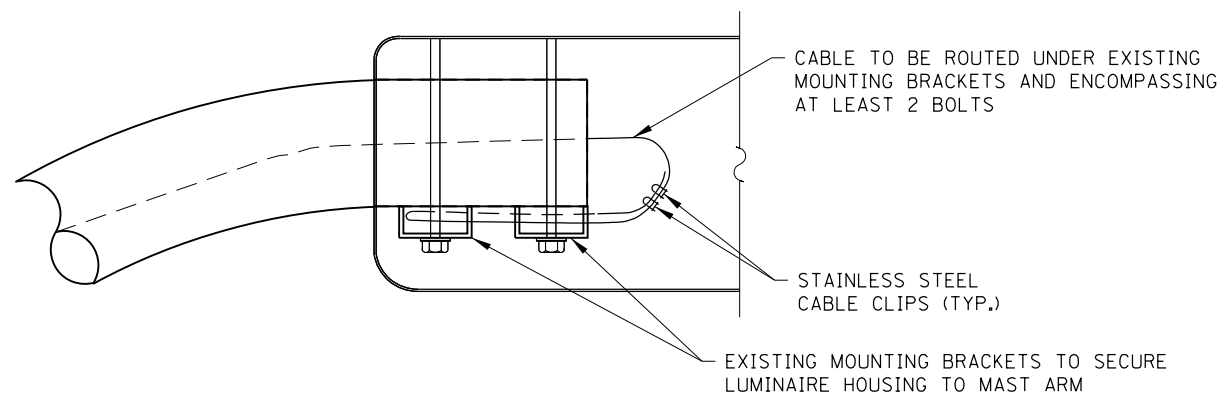

**LIGHT STANDARD - TRUSS ARM**  
(TWIN TRUSS ARM SHOWN, TWIN MAST ARM SIMILAR)

N.T.S.



**DETAIL A**  
N.T.S.

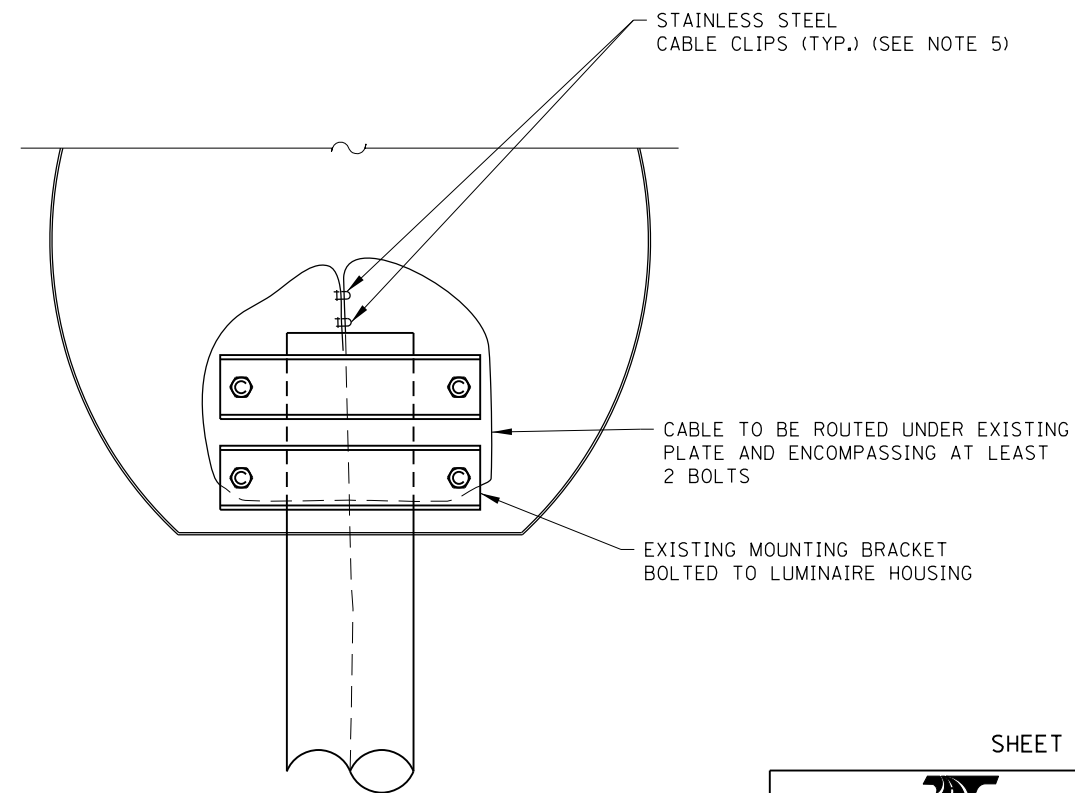

**BOTTOM VIEW**  
N.T.S.

**NOTES:**

1. POLE CAP TO BE REMOVED AND LUMINAIRE LID TO BE OPENED FOR PLACEMENT OF THE CABLE ASSEMBLY AND PUT BACK IN PLACE. NEW CAP SCREWS SHALL BE USED.
2. THE BREAKING STRENGTH OF THE ASSEMBLED CABLE SHALL BE 1,700 POUNDS MINIMUM. ALLOW FOR 9" TO 12" SLACK IN THE CABLE.
3. ALUMINUM TAG WITH POLE IDENTIFICATION NUMBERS AS PER SPECIAL PROVISIONS.
4. CONTRACTOR SHALL ROUTE CABLE WITHIN LUMINAIRE IN SUCH A WAY THAT IT DOES NOT BECOME PINCHED BETWEEN THE MAST ARM AND MOUNTING BRACKET.
5. CABLE LOOPS SHALL BE CLOSED SUCH THAT EACH END OF THE CABLE PASSES THROUGH CLIPS IN OPPOSING DIRECTIONS.
6. MINIMIZE SLACK WITHIN LUMINAIRE.

*Paul Kovacs*  
APPROVED, CHIEF ENGINEERING OFFICER DATE 2-22-2018

DATE	REVISIONS
3-01-2020	REVISED BRACKET AND ROUTING DETAILS.



MAST ARM  
CABLE ASSEMBLY  
(TWIN MAST ARM)

STANDARD H16-01

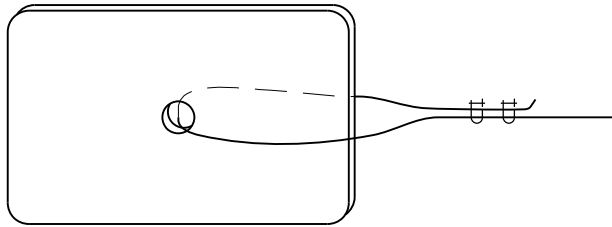
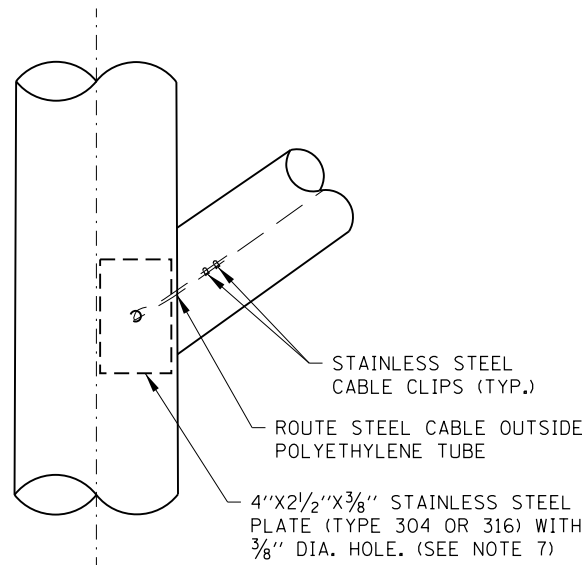
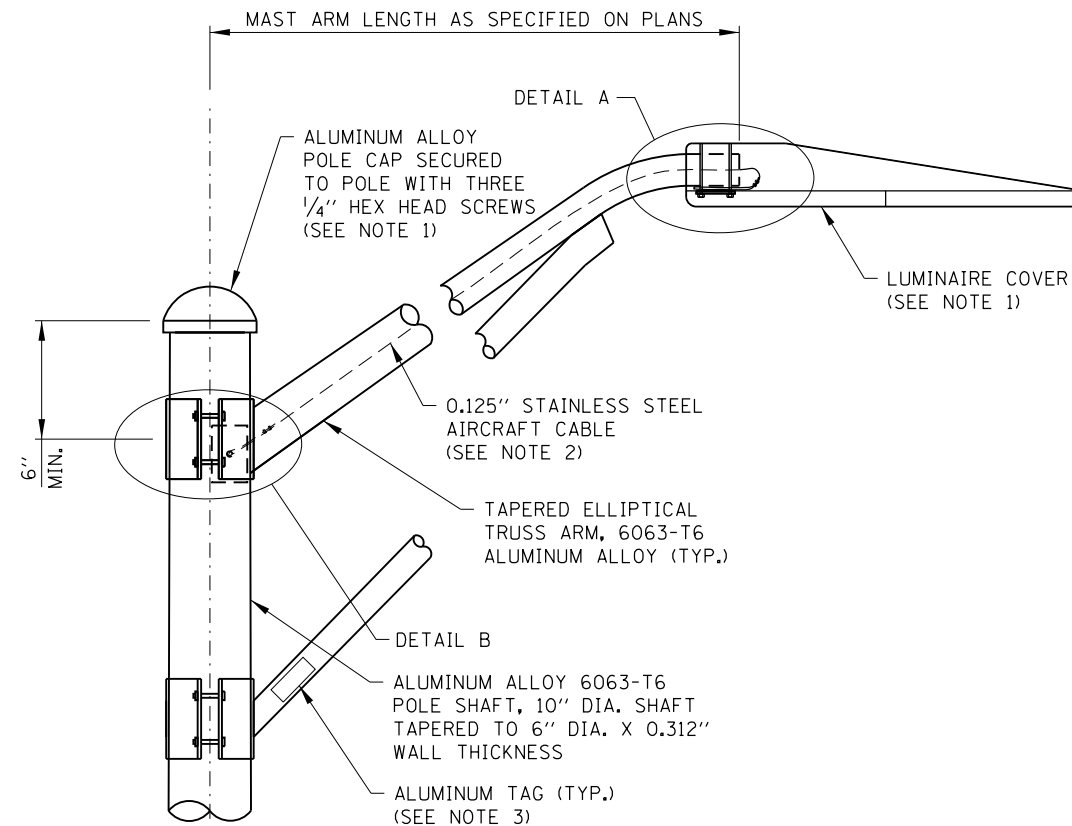

PLATE ATTACHMENT DETAIL



DETAIL B  
 (BRACKET CLAMPS OMITTED FOR CLARITY)  
 N.T.S.



LIGHT STANDARD - TRUSS ARM  
 (SINGLE TRUSS ARM SHOWN, SINGLE MAST ARM SIMILAR)

N.T.S.

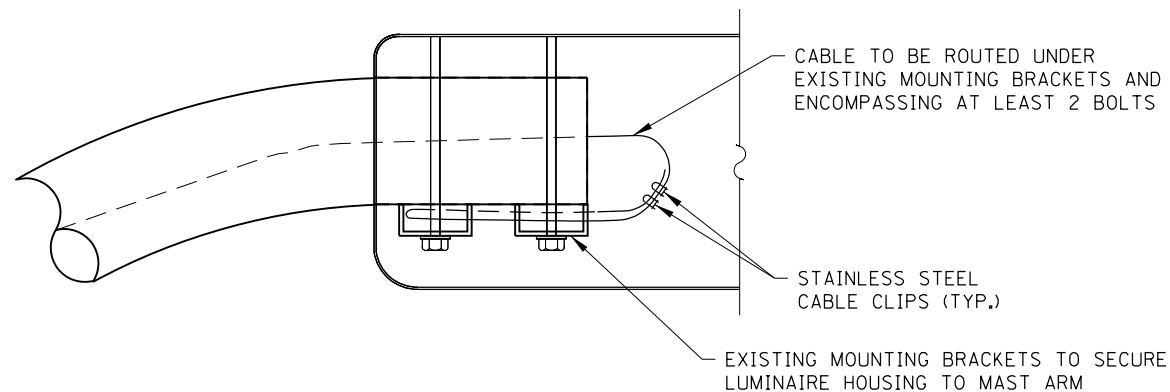

DETAIL A  
 N.T.S.

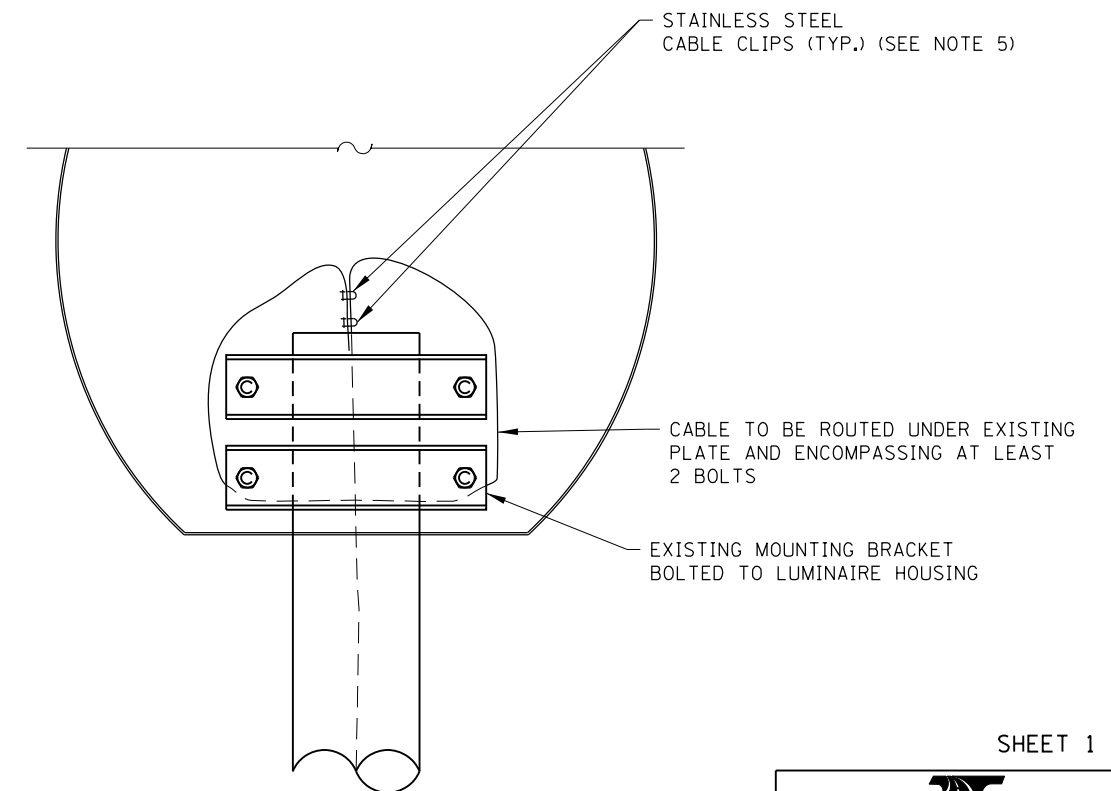

BOTTOM VIEW  
 N.T.S.

NOTES:

1. POLE CAP TO BE REMOVED AND LUMINAIRE LID TO BE OPENED FOR PLACEMENT OF THE CABLE ASSEMBLY AND PUT BACK IN PLACE. NEW CAP SCREWS SHALL BE USED.
2. THE BREAKING STRENGTH OF THE ASSEMBLED CABLE SHALL BE 1,700 POUNDS MINIMUM. ALLOW FOR 9" TO 12" SLACK IN THE CABLE.
3. ALUMINUM TAG WITH POLE IDENTIFICATION NUMBERS AS PER SPECIAL PROVISIONS.
4. CONTRACTOR SHALL ROUTE CABLE WITHIN LUMINAIRE IN SUCH A WAY THAT IT DOES NOT BECOME PINCHED BETWEEN THE MAST ARM AND MOUNTING BRACKET.
5. CABLE LOOPS SHALL BE CLOSED SUCH THAT EACH END OF THE CABLE PASSES THROUGH CLIPS IN OPPOSING DIRECTIONS.
6. MINIMIZE SLACK WITHIN LUMINAIRE.
7. ALL PLATE EDGES SHALL BE SMOOTH.

APPROVED: *Paul Kovacs* DATE 2-22-2018  
 CHIEF ENGINEERING OFFICER

DATE	REVISIONS
3-01-2020	REVISED BRACKET AND ROUTING DETAILS.



MAST ARM  
 CABLE ASSEMBLY  
 (SINGLE MAST ARM)

STANDARD H17-01

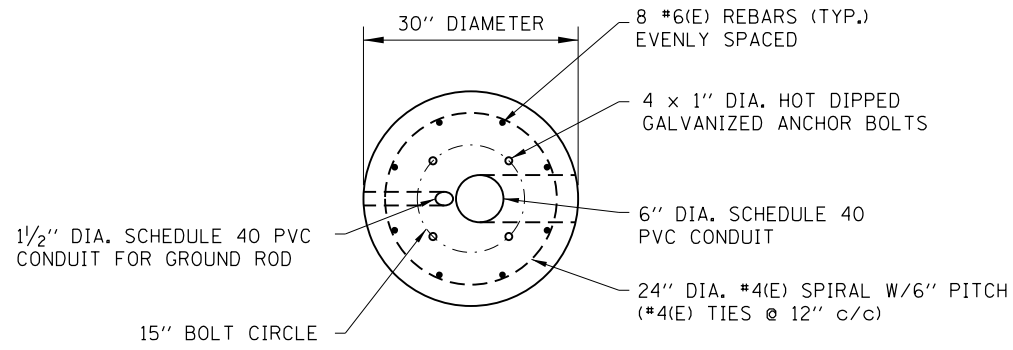

PLAN

**NOTES:**

1. FOR DETAILS OF FUSE HOLDER, POLE BASE WIRING AND CONDUCTOR SPLICE SEE STANDARD H2.
2. ALL REINFORCEMENT BARS SHALL BE EPOXY COATED.
3. ALL EQUIPMENT SHALL BE GROUNDED AND BONDED IN ACCORDANCE WITH THE NATIONAL ELECTRICAL CODE AND THE NATIONAL ELECTRICAL SAFETY CODE.
4. POLE SHALL BE MOUNTED AND WIRED PER DETAIL FOR "BARRIER WALL MOUNTED UNITS" ON LIGHT STANDARD DETAILS (STANDARD H2)

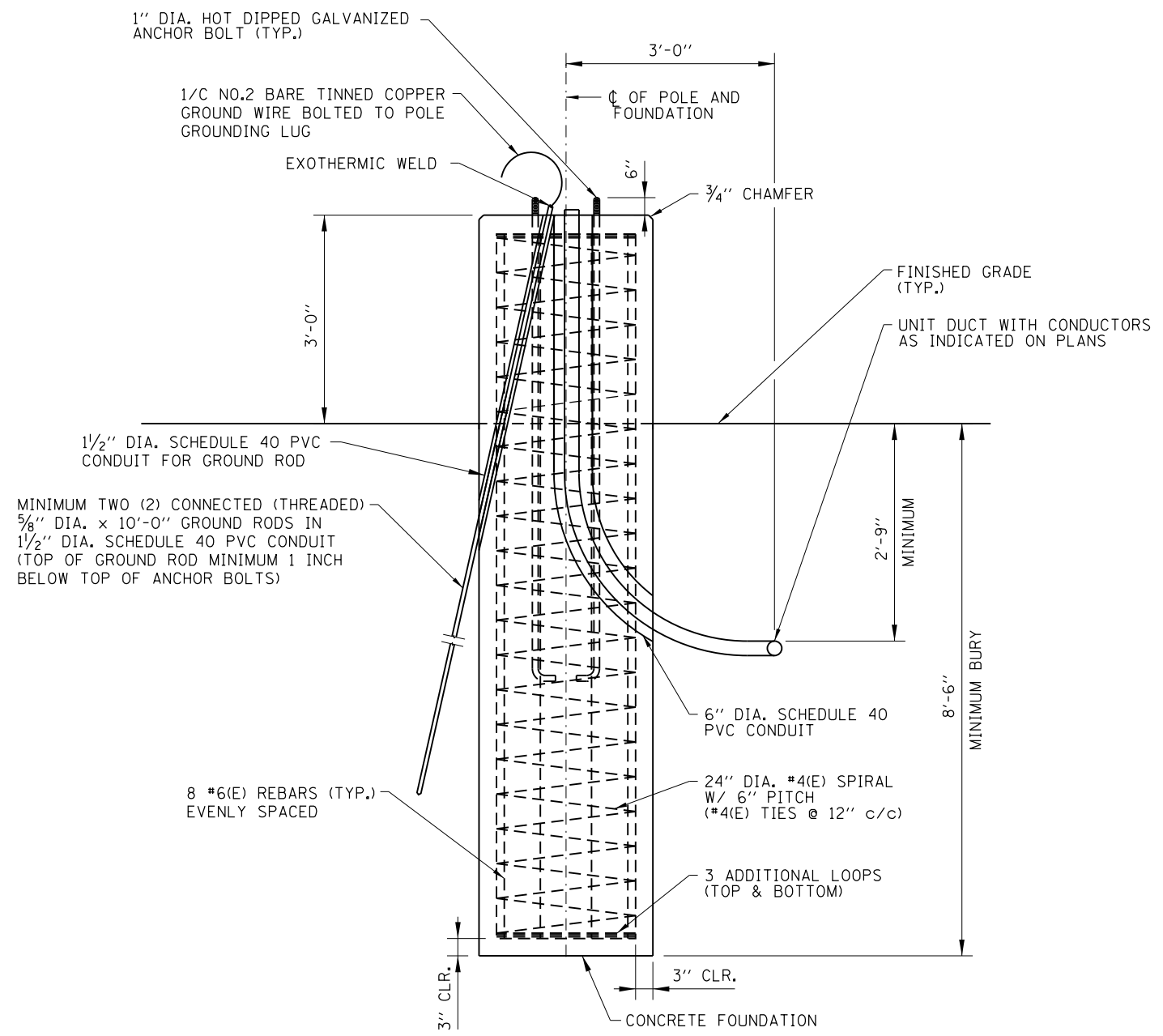

ELEVATION

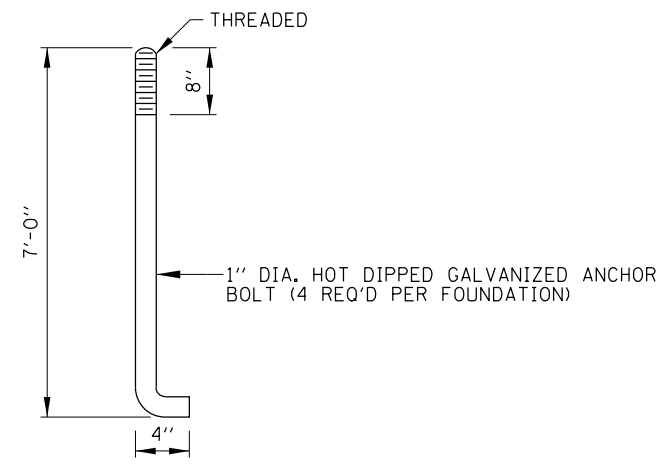

ANCHOR BOLT DETAIL

*Paul Kovacs*  
 APPROVED, CHIEF ENGINEERING OFFICER DATE 3-1-2019

DATE	REVISIONS

SHEET 1 OF 1



PARKING LOT  
 LIGHT FOUNDATION  
 DETAILS

STANDARD H18-00